

GENERAL NOTES

1. Reinforcement bars designated (E) shall be epoxy coated.
2. Plan dimensions and details relative to existing plans are subject to nominal construction variations. The Contractor shall field verify existing dimensions and details affecting new construction and make necessary approved adjustments prior to construction or ordering of materials. Such variations shall not be cause for additional compensation for a change in scope of the work, however, the Contractor will be paid for the quantity actually furnished at the unit price bid for the work.
3. Layout of the slope protection system may be varied to suit ground conditions in the field as directed by the Engineer.
4. Slipforming of the parapets will not be allowed.

INDEX OF SHEETS

S1	General Plan and Elevation
S2	General Data
S3	Stage Construction Details
S4	Temporary Concrete Barrier for Stage Construction
S5	Top of West Approach Slab Elevations
S6	Top of East Approach Slab Elevations
S7	Superstructure Plan
S8	Superstructure Cross Section
S9,S10	Superstructure Details
S11,S12,S13,S14	Precast Bridge Approach Slab
S15	Bicycle Railing and Parapet Railing Details
S16	Expansion Joint Details
S17	21" x 48" PPC Deck Beam
S18	21" x 48" PPC Deck Beam Details
S19	Abutments Removal
S20	Abutments
S21	Pier 1 Repairs
S22	Pier 2 Repairs
S23	Bar Splicer Assembly Details

TOTAL BILL OF MATERIAL

ITEM	UNIT	SUPER	SUB	TOTAL
Stone Riprap, Class A4	Ton	-	1380	1380
Filter Fabric	Sq. Yd.	-	1055	1055
Removal of Existing Superstructures	Each	1	-	1
Concrete Removal	Cu. Yd.	-	19.2	19.2
Structure Excavation	Cu. Yd.	-	11	11
Concrete Structures	Cu. Yd.	-	107.0	107.0
Concrete Superstructure	Cu. Yd.	117.8	-	117.8
Bridge Deck Grooving	Sq. Yd.	1191	-	1191
Protective Coat	Sq. Yd.	1847	-	1847
Precast Prestressed Concrete Deck Beams, 21" Depth	Sq. Ft.	9427	-	9427
Furnishing and Erecting Structural Steel	Pound	-	20420	20420
Reinforcement Bars, Epoxy Coated	Pound	37370	10760	48130
Bar Splicers	Each	191	88	279
Bicycle Railing	Foot	381	-	381
Parapet Railing	Foot	381	-	381
Name Plates	Each	1	-	1
Preformed Joint Strip Seal	Foot	358	-	358
Anchor Bolts, 5/8"	Each	-	36	36
Epoxy Crack Injection	Foot	-	27	27
Concrete Wearing Surface, 5"	Sq. Yd.	1572	-	1572
Precast Bridge Approach Slab	Sq. Ft.	4185	-	4185
Structural Repair of Concrete (Depth Less Than 5 Inches)	Sq. Ft.	-	75	75
Temporary Sheet Piling	Sq. Ft.	-	71	71

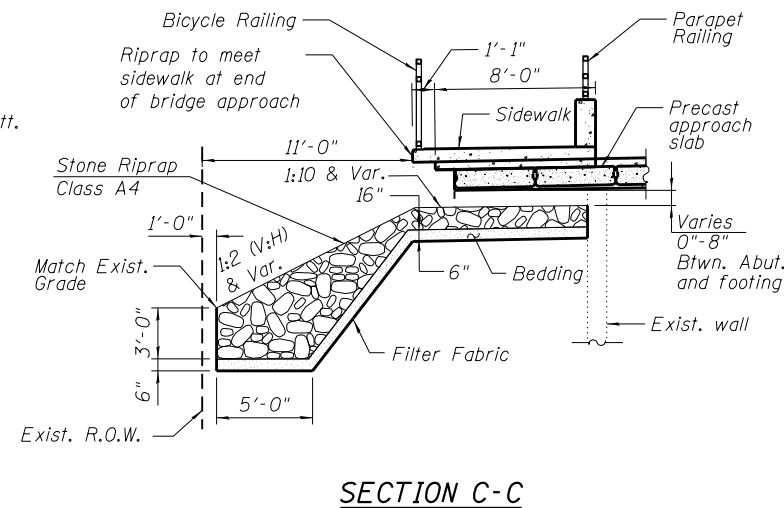
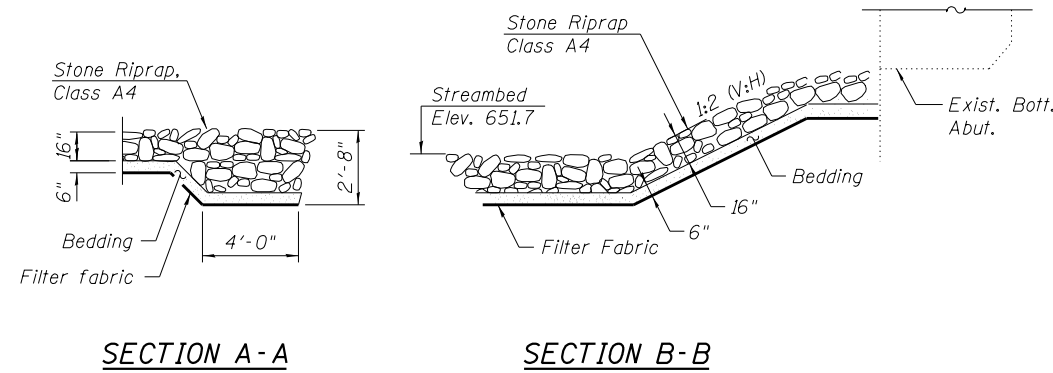

M:\JL 132 over Des\James River\12-15-00\1\DRAWINGS\Structural\Final Plans\CADD Sheets\049-0062.02.gen notes.dgn



USER NAME = JPS	DESIGNED - OY	REVISED
FILE NAME = 049-0062.02.gen notes.dgn	CHECKED - DB	REVISED
PLOT DATE = 12/17/2013	DRAWN - CM	REVISED
	CHECKED - OY	REVISED

**STATE OF ILLINOIS
DEPARTMENT OF TRANSPORTATION**

**GENERAL DATA
STRUCTURE NO. 049-0062**

SHEET NO. S2 OF S23 SHEETS

F.A.P. RTE.	SECTION	COUNTY	TOTAL SHEETS	SHEET NO.
541	X-6B-R	LAKE	93	43
ILLINOIS FED. AID PROJECT			CONTRACT NO. 60N22	