

EXISTING TYPICAL SECTION

STA. 0+00 TO STA. 4+00

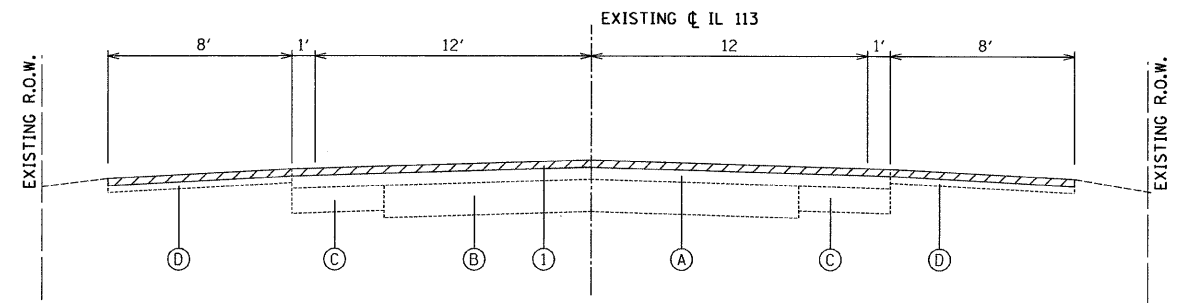

EXISTING TYPICAL SECTION

STA. 4+00 TO STA. 12+08

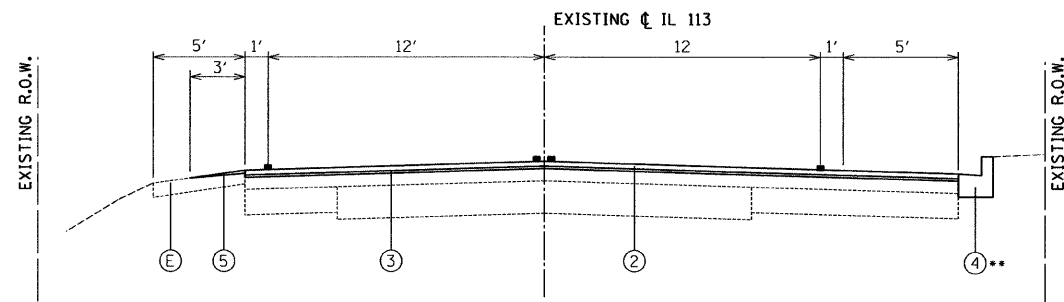

PROPOSED TYPICAL SECTION

STA. 0+00 TO STA. 4+00

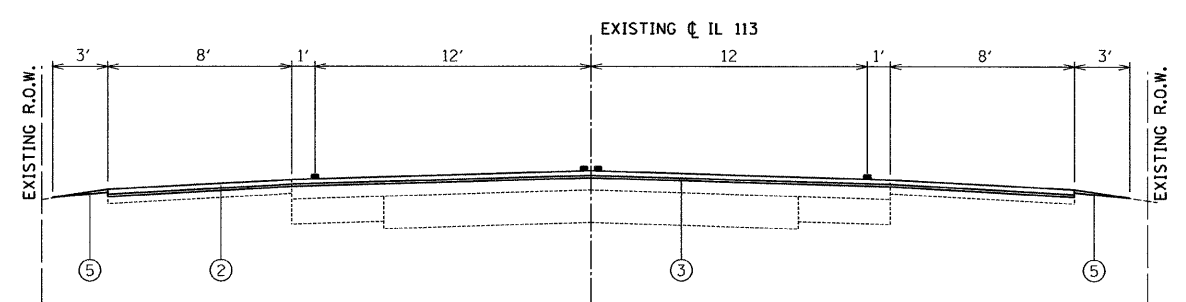

PROPOSED TYPICAL SECTION

STA. 4+00 TO STA. 12+08

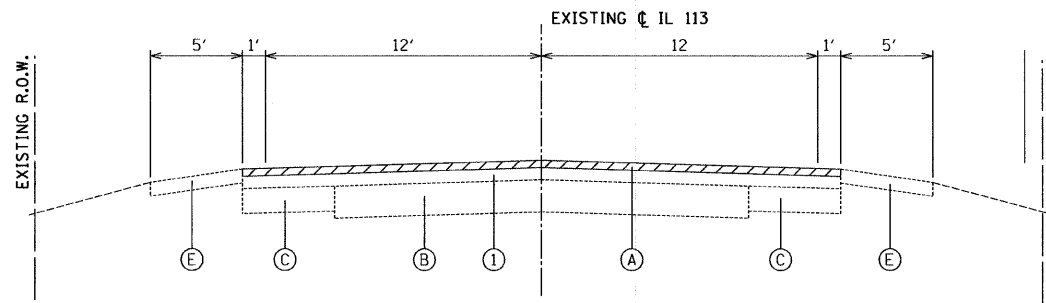

EXISTING TYPICAL SECTION

STA. 12+08 TO STA. 89+11

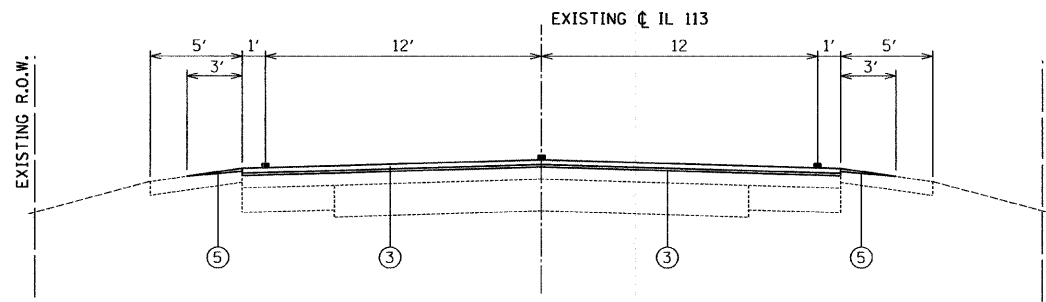

PROPOSED TYPICAL SECTION

STA. 12+08 TO STA. 89+11

EXISTING CONDITIONS:

- (A) HOT-MIX ASPHALT SURFACE COURSE, 5"±
- (B) P.C.C. PAVEMENT, 9"±
- (C) HOT-MIX ASPHALT BASE COURSE, 8"
- (D) HOT-MIX ASPHALT SHOULDERS
- (E) AGGREGATE SHOULDERS

▨ ITEMS TO BE REMOVED

PROPOSED IMPROVEMENTS:

- ① HOT-MIX ASPHALT SURFACE REMOVAL, 2 1/4"
- ② HOT-MIX ASPHALT SURFACE COURSE, MIX "D" N70, 1 1/2"
- ③ POLYMERIZED LEVELING BINDER (MACHINE METHOD), IL-4.75, N50, 3/4"
- ④ COMBINATION B6.12 CONCRETE CURB AND GUTTER AND REPLACEMENT (AS DETERMINED BY THE ENGINEER)
- ⑤ AGGREGATE WEDGE SHOULDER, TYPE B
 - PAVEMENT MARKING
 - LOCATIONS AS DETERMINED BY THE ENGINEER

THE CONTRACTOR SHALL MILL BEFORE PATCHING

| HOT-MIX ASPHALT MIXTURE REQUIREMENTS | |
|--|------------------|
| MIXTURE TYPE | AIR VOIDS @ Ndes |
| HOT-MIX ASPHALT SURFACE COURSE, MIX "D", N70 (IL 9.5mm) | 4% @ 70 GYR |
| POLYMERIZED LEVELING BINDER (MACHINE METHOD), IL 4.75, N50 | 4% @ 50 GYR |
| CLASS D PATCHES (HMA BINDER IL 19mm) | 4% @ 70 GYR |

THE UNIT WEIGHT USED TO CALCULATE ALL HOT-MIX ASPHALT SURFACE MIXTURE A IS 112 LBS/SQ YD/IN.

THE "AC TYPE" FOR POLYMERIZED HMA MIXES SHALL BE "SBS/SBR PG 70-22" AND FOR NON-POLYMERIZED HMA THE "AC TYPE" SHALL BE "PG 64-22" UNLESS MODIFIED BY DISTRICT ONE SPECIAL PROVISIONS.

FOR "PERCENT OF RAP" SEE DISTRICT ONE SPECIAL PROVISIONS.

| | | | | | | | | | | | | |
|-------------|-----------------------------|-------------------|-----------|---|---|---------------------------|-------------------------|-------------|-----------------|--------------------|--|--|
| FILE NAME = | USER NAME = .USER. | DESIGNED - AR/EF | REVISED - | STATE OF ILLINOIS DEPARTMENT OF TRANSPORTATION | IL 113 - COAL CITY RD TO MAIN ST. TYPICAL SECTIONS | F.A.S. RTE. 2320 | SECTION 113X-RS-4 | COUNTY WILL | TOTAL SHEETS 13 | SHEET NO. 4 | | |
| *FILEL# | PLOT SCALE = 50.0000' / IN. | DRAWN - AR/EF | REVISED - | | | SCALE: | SHEET NO. 1 OF 1 SHEETS | STA. | TO STA. | CONTRACT NO. 60L59 | | |
| | PLOT DATE = 9/7/2010 | CHECKED - RS | REVISED - | | | ILLINOIS FED. AID PROJECT | | | | | | |
| | | DATE - 10-16-2010 | REVISED - | | | | | | | | | |