

STAGE III

STAGE III NOTES

1. SUGGESTED SEQUENCE OF CONSTRUCTION: PAVEMENT PATCHING, HMA SURFACE REMOVAL AND PROPOSED HMA COURSES AS DETAILED IN EACH OPERATION. THE CONTRACTOR MAY SUBMIT AN ALTERNATE SEQUENCE OF OPERATIONS PLAN FOR APPROVAL OF THE ENGINEER. IF THE ALTERNATE SEQUENCE OF OPERATIONS CONTAINS GRADE DIFFERENTIALS BETWEEN LANES GREATER THAN 2", A LONGITUDINAL WEDGE WILL BE REQUIRED. THE CONTRACTOR SHALL SUBMIT FOR APPROVAL THE LOCATION(S) AND DETAIL(S) FOR THE LONGITUDINAL WEDGE IF REQUIRED. THE COST FOR THE PLACEMENT AND REMOVAL OF THE WEDGE SHALL NOT BE PAID FOR SEPARATELY BUT SHALL BE INCLUDED IN THE COST OF VARIOUS HMA ITEMS. RAMP WORK WILL BE COMPLETED USING DISTRICT DETAIL TC-8 - FREEWAY AND EXIT RAMP CLOSURE DETAILS.
2. LANE AND RAMP CLOSURES ALLOWED AS STIPULATED IN THE SPECIAL PROVISIONS. CONTRACTOR MAY NOT CLOSE ADJACENT EXIT OR ENTRANCE RAMP AT THE SAME TIME.
3. LANE CLOSURES FOR RESURFACING OPERATIONS SHALL BE AS STIPULATED IN THE SPECIAL PROVISION "KEEPING THE EXPRESSWAY OPEN TO TRAFFIC."
4. LANE CLOSURES PER STANDARDS 701400, 701401 AND 701446.
5. REDUCE LANE WIDTH USING 35:1 TAPER PER DISTRICT DETAIL TC-9 - TRAFFIC CONTROL DETAILS FOR FREEWAY SINGLE AND MULTI-LANE WEAVE, A W5-1 (48" X 48") ROAD NARROWS SIGN WILL BE ERRECTED 500' IN ADVANCE OF THE TAPER.
6. THE CONTRACTOR SHALL ERECT ROAD CONSTRUCTION AHEAD SIGNS (W20-110310-48) WITH FLASHING BEACON ON ALL ARTERIAL ROADWAYS APPROACHING INTERCHANGE RAMP.
7. GRADE DIFFERENTIAL BETWEEN LANES SHALL NOT EXCEED 2".
8. PARTIAL MILLING OF PAVEMENT FOR AN OPERATION WILL NOT BE PAID FOR SEPARATELY. BUT WILL BE PAID FOR AT THE FINAL MILLING THICKNESS SHOWN ON THE TYPICAL SECTIONS.
9. EPOXY PAVEMENT MARKING LINES SHALL BE USED FOR TEMPORARY PAVEMENT MARKINGS.
10. REMOVAL OF EXISTING PAVEMENT MARKING, WHEN REQUIRED, SHALL BE PAID FOR AS "PAVEMENT MARKING REMOVAL."
11. EXISTING OR TEMPORARY PAVEMENT MARKINGS REMOVED DURING MILLING OPERATIONS WILL NOT BE PAID FOR SEPARATELY.
12. CASTINGS EXPOSED IN TRAVEL LANES SHALL BE PROTECTED PER APPLICABLE PORTIONS OF ARTICLE 603.07 OF THE STANDARD SPECIFICATIONS. THIS WORK WILL NOT BE PAID FOR SEPARATELY, BUT SHALL BE INCLUDED IN THE VARIOUS HMA/SMA BINDER AND SURFACE COURSES PLACED.
13. OMIT STAGE III OPERATIONS THROUGH BRIDGE AND CONCRETE SECTIONS.
14. SIGNS SHALL BE INSTALLED AS INSTRUCTED BELOW.



SIGN SHALL BE INSTALLED IN ADVANCE OF ALL OPEN/EXIT RAMP WHEN THE RIGHT LANES ARE CLOSED.



SIGN SHALL BE INSTALLED ON BOTH SIDES OF THE ROADWAY 500' IN ADVANCE OF AREAS WHERE THERE IS A GRADE DIFFERENTIAL BETWEEN LANES, AFTER EACH ENTRANCE RAMP AND A MINIMUM OF EVERY MILE.

15. THE CONTRACTOR SHALL COORDINATE THE ROADWAY AND STRUCTURAL WORK SO BITUMINOUS MATERIALS ARE NOT TRACKED ON THE BRIDGE DECKS BEFORE BEING SEALED.
16. "EPOXY PAVEMENT MARKING - LETTERS AND SYMBOLS" SHALL BE INSTALLED ON MAINLINE ROADWAY DURING STAGE III OPERATIONS, IN LOCATIONS WHERE LETTERS/SYMBOLS PAVEMENT MARKINGS EXIST PRIOR TO SURFACE REMOVAL.
17. WORK ZONE SPEED LIMIT SIGNS SHALL REMAIN IN PLACE UNTIL ALL BINDER IS PLACED.

LEGEND

- ① EXISTING PAVEMENT MARKING
- ② EPOXY PAVEMENT MARKING - LINE 5" (WHITE 10' DASH, 30' SKIP)
- ③ EPOXY PAVEMENT MARKING - LINE 4" (YELLOW LEFT & WHITE RIGHT)
- ④ PROPOSED PAVEMENT MARKING. SEE PAVEMENT MARKING PLANS.

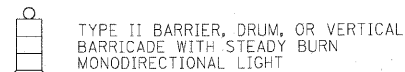

TYPE II BARRIER, DRUM, OR VERTICAL BARRICADE WITH STEADY BURN MONODIRECTIONAL LIGHT



BITUMINOUS SURFACE REMOVAL



HMA/SMA BINDER AND SURFACE COURSES

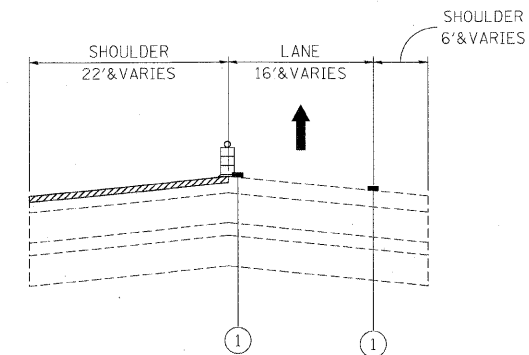

STAGE III - OPERATION ONE - EB IL-38 TO I-88 RAMP
BITUMINOUS SURFACE REMOVAL 2" - SHOULDER

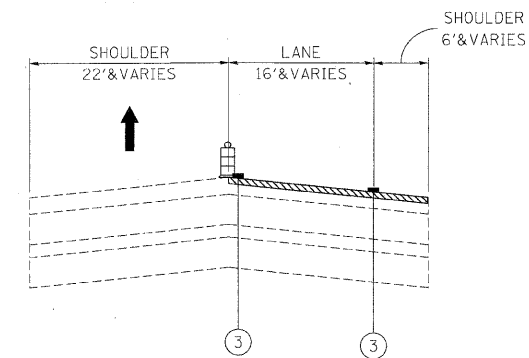

STAGE III - OPERATION TWO - EB IL-38 TO I-88 RAMP
BITUMINOUS SURFACE REMOVAL 2" - LANE AND SHOULDER

FILE NAME =	DESIGNED -- AJP	REVISED --	benesch	STATE OF ILLINOIS DEPARTMENT OF TRANSPORTATION	MAINTENANCE OF TRAFFIC TYPICAL SECTION - STAGE 3	F.A.I. RTE.	SECTION	COUNTY	TOTAL SHEETS	SHEET NO.
USER NAME = tblank	DRAWN -- TMB	REVISED --				290	(3435, ETC., 3838)RS-5	COOK	264	122
PLOT DATE = 1/25/2010	CHECKED -- JUT	REVISED --				CONTRACT NO. 60C52				
DATE -- 1/25/10	REVISED --	SCALE:				SHEET NO. 58 OF 62 SHEETS	STA. TO STA.	FED. ROAD DIST. NO.	ILLINOIS FED. AID PROJECT	