

EXISTING TYPICAL SECTION

MAINLINE RAMPS
(FAI -290)

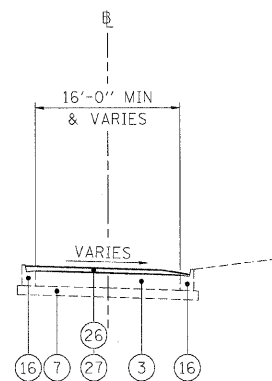

PROPOSED TYPICAL SECTION

MAINLINE RAMPS
(FAI -290)

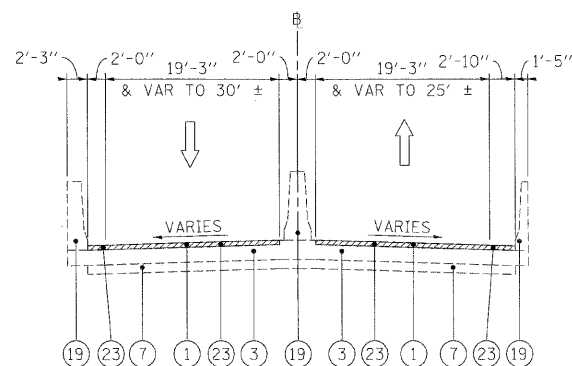

EXISTING TYPICAL SECTION

HARLEM AVE

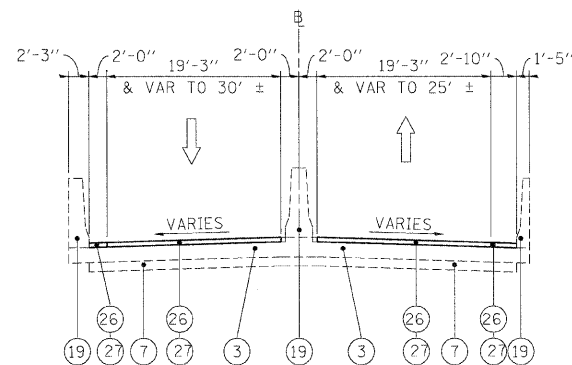

PROPOSED TYPICAL SECTION

HARLEM AVE

LEGEND

- ① EXISTING HMA OVERLAY, VARIES
- ② EXISTING C.R.C. PAVEMENT, 12"
- ③ EXISTING P.C.C. PAVEMENT, 10"
- ④ EXISTING C.R.C. PAVEMENT, 9"
- ⑤ EXISTING C.R.C. PAVEMENT
- ⑥ EXISTING P.C.C. BASE COURSE
- ⑦ EXISTING STABILIZED SUB-BASE, 4"
- ⑧ EXISTING SUB-BASE GRANULAR MATERIAL, TYPE A
- ⑨ EXISTING PGE WRAPPED IN FABRIC (VARIOUS LOCATIONS)
- ⑩ EXISTING PIPE UNDERDRAIN
- ⑪ EXISTING P.C.C. SHOULDER
- ⑫ EXISTING STABILIZED MEDIAN SURFACE
- ⑬ EXISTING BITUMINOUS SHOULDER
- ⑭ EXISTING AGGREGATE SHOULDER
- ⑮ EXISTING AGGREGATE SHOULDER, TYPE B
- ⑯ EXISTING COMB. CONC. CURB & GUTTER, TYPE M-2.12
- ⑰ EXISTING COMB. CONC. CURB & GUTTER, TYPE M-6.24
- ⑱ EXISTING COMB. CONC. CURB & GUTTER, TYPE B-6.24
- ⑲ EXISTING P.C.C. BARRIER WALL
- ⑳ EXISTING STEEL PLATE BEAM GUARDRAIL
- ㉑ HOT-MIX ASPHALT SURFACE REMOVAL 4"
- ㉒ HOT-MIX ASPHALT SURFACE REMOVAL 3 3/4"
- ㉓ HOT-MIX ASPHALT SURFACE REMOVAL 3 1/4"
- ㉔ POLYMERIZED HOT-MIX ASPHALT SURFACE COURSE, STONE MATRIX ASPHALT, N80, 2"
- ㉕ POLYMERIZED HOT-MIX ASPHALT BINDER COURSE, STONE MATRIX ASPHALT, N80, 2"
- ㉖ HOT-MIX ASPHALT SURFACE COURSE, MIX "D", N70, 1 1/2"
- ㉗ HOT-MIX ASPHALT BINDER COURSE, IL-19.0, N70, 2 1/4"
- ㉘ NOT USED
- ㉙ PROPOSED SHOULDER RUMBLE STRIP (STD. 642001-01)
- ㉚ HOT-MIX ASPHALT SHOULDER REMOVAL AND REPLACEMENT (SPECIAL)

NOTES

1. THE CONTRACTOR SHALL MAINTAIN THE EXISTING CROSS SLOPES.
2. THE EXISTING HMA IN THE FLAG OF THE CURB AND GUTTER SHALL BE REMOVED AND REPLACED AT NO ADDITIONAL COST. THESE COSTS SHALL BE INCLUDED IN THE UNIT PRICES FOR THE VARIOUS MILLING AND RESURFACING OPERATIONS MEASURED TO THE EDGE OF THE SHOULDER.
3. THE COST OF HAND REMOVAL OF HMA SURFACE AROUND CASTINGS SHALL BE INCLUDED IN THE COST OF HMA SURFACE REMOVAL OF THE THICKNESS SPECIFIED.
4. THE CONTRACTOR SHALL PATCH FIRST BEFORE MILLING.

FILE NAME =	DESIGNED - AJP	REVISED -	benesch	STATE OF ILLINOIS DEPARTMENT OF TRANSPORTATION	TYPICAL SECTIONS I-290 RAMPS		F.A.I. RTE.	SECTION	COUNTY	TOTAL SHEETS	SHEET NO.
... \proj\in\ABC_C2_298_ramp_typ_21.dgn	DRAWN - TMB	REVISED -			290	(3131, ETC., 3435)RS-6	COOK	215	16		
USER NAME = tblank	CHECKED - JMM	REVISED -			CONTRACT NO. 60K10						
PLOT DATE = 1/25/2010	DATE - 1/25/10	REVISED -			FED. ROAD DIST. NO. [ILLINOIS] FED. AID PROJECT						
			SCALE: N.T.S.	SHEET NO. 10 OF 10 SHEETS	STA. TO STA.						