

F.A.S.	SECTION	COUNTY	TOTAL SHEETS	SHEET NO.
800	07-00075-00-RS	WABASH	4	1
FED. ROAD DIST. NO. 7		ILLINOIS	LANCASTER-FRIENDSVILLE RD	
LEC JOB # H081006WB			CONTRACT # 95594	

**INDEX OF SHEETS**

SHEET NO.	DESCRIPTION
1	TITLE SHEET
2	TYPICAL SECTIONS, SUMMARY OF QUANTITIES, GENERAL NOTES, MISCELLANEOUS DETAILS
3	DETAILS OF INTERSECTIONS, SIDEROADS, AND TAPERS
4	SCHEDULES

**STATE OF ILLINOIS  
DEPARTMENT OF TRANSPORTATION  
DIVISION OF HIGHWAYS**

**PLANS FOR PROPOSED  
FEDERAL-AID SECONDARY PROJECT**

**F.A.S. 800 (CH 11) SECTION 07-00075-00-RS WABASH COUNTY**

**PROJECT RS-800(123) JOB NO. C-97-109-09**

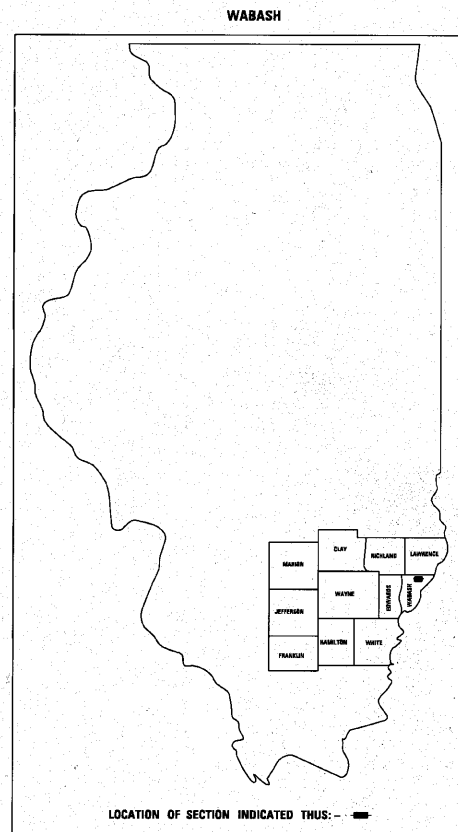

323 W. 3RD ST.  
P.O. BOX 160  
MT. CARMEL, IL  
62863  
PHONE:  
(618)-262-8651  
FAX:  
(618)-263-3327

405 W. STATE ST.  
SUITE 1  
PRINCETON, IN  
47670  
PHONE:  
(812)-386-7611  
FAX:  
(812)-385-2812



PROFESSIONAL DESIGN FIRM  
LAND SURVEY & PROFESSIONAL ENGINEERING CORPORATION  
184-00887  
(62-032435)(35-002769)



AARON M. MEFFORD  
NAME  
*Aaron Mefford*  
SIGNATURE  
10-20-10  
DATE  
11-30-11  
EXPIRES

**HIGHWAY STANDARDS**

00001-06	STANDARD SYMBOLS, ABBREVIATIONS & PATTERNS
406201-01	MAILBOX TURNOUT
701006-03	OFF-RD OPERATIONS 2L, 2W, 4.5 m (15') TO PAVEMENT EDGE FOR SPEEDS ≥ 45 MPH
701301-04	LANE CLOSURE 2L, 2W, SHORT TIME OPERATIONS
701306-03	LANE CLOSURE 2L, 2W, SLOW MOVING OPERATIONS - DAY ONLY FOR SPEEDS ≥ 45 MPH
701311-03	LANE CLOSURE 2L, 2W MOVING OPERATIONS - DAY ONLY
701336-06	LANE CLOSURE 2L, 2W, WORK AREAS IN SERIES FOR SPEEDS ≥ 45 MPH
701971-01	TRAFFIC CONTROL DEVICES
780001-02	TYPICAL PAVEMENT MARKINGS
781001-03	TYPICAL APPLICATIONS RAISED REFLECTIVE PAVEMENT MARKERS

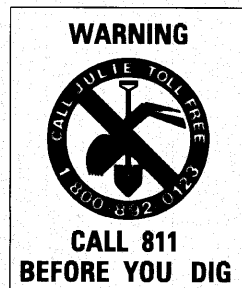
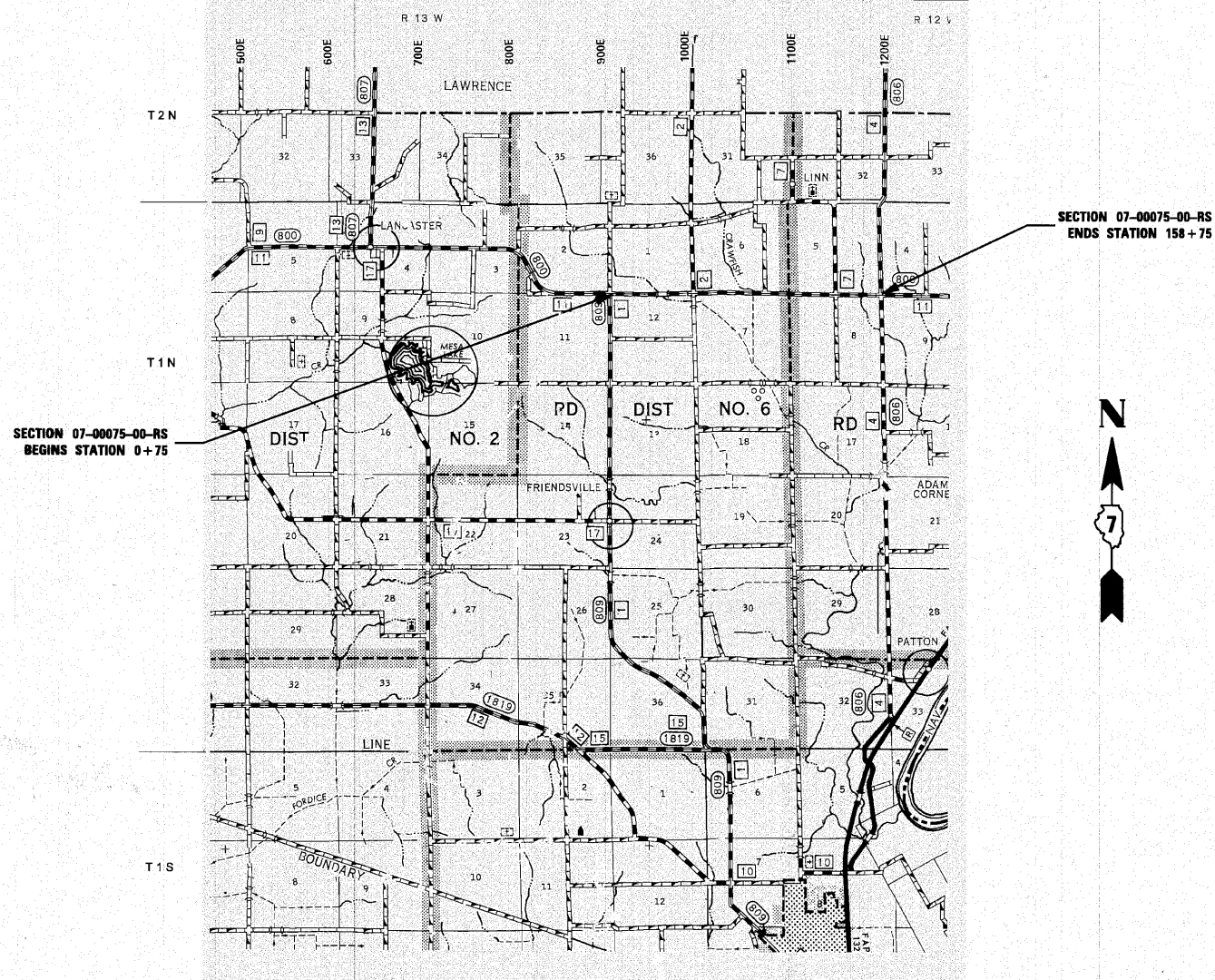

CONTRACT NO. = 95594  
DESIGN CLASS - MAJOR COLLECTOR  
CURRENT A.D.T. = 600  
DESIGN SPEED = 50 MPH

**LAYOUT**

APPROXIMATE SCALE 1 INCH = 1 MILE

GROSS LENGTH	15,800.00 FT	2.992 MILES
NET LENGTH	15,800.00 FT	2.992 MILES

STATE OF ILLINOIS  
DEPARTMENT OF TRANSPORTATION

APPROVED October 21 20 10  
*Dustin K. Bredin*  
COUNTY ENGINEER

PASSED November 4 20 10  
*Maurice L. East*  
DISTRICT SEVEN ENGINEER OF  
LOCAL ROADS & STREETS

Releasing For  
Bid Based on  
Limited Review November 4 20 10  
*Roger L. Duval*  
DEPUTY DIRECTOR OF HIGHWAYS,  
REGION FOUR ENGINEER

**TYPICAL CROSS SECTION EXISTING**

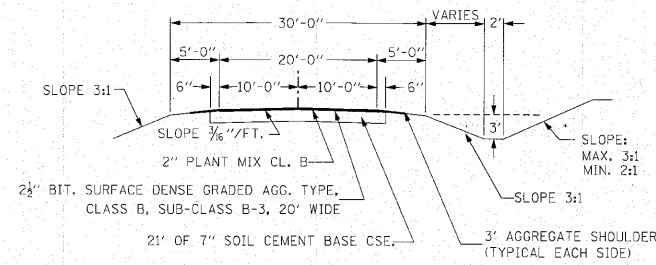

**TYPICAL CROSS SECTION PROPOSED**

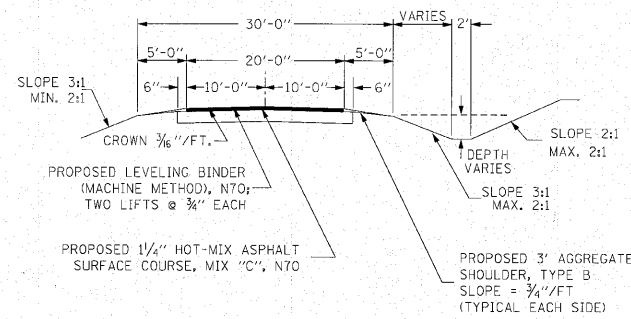

**GENERAL NOTES:**

THIS SECTION CONSISTS OF LEVELING BINDER (MACHINE METHOD), N70, AND HOT-MIX ASPHALT SURFACE COURSE, MIX "C", N70, AGGREGATE SHOULDERS, AND OTHER MISCELLANEOUS ITEMS NECESSARY TO COMPLETE THE PROJECT, ALL IN ACCORDANCE WITH THE PLANS, SPECIAL PROVISIONS AND "STANDARD SPECIFICATIONS FOR ROAD AND BRIDGE CONSTRUCTION" ADOPTED JANUARY 1, 2007.

THE EXISTING GRADE, ALIGNMENT, DRAINAGE STRUCTURES, BASE AND SURFACE WERE CONSTRUCTED UNDER SECTIONS 270, 87-00053-00-RS AND SHALL REMAIN IN PLACE. ALL STATIONS REFERRED TO IN THE PLANS AND PROPOSAL ARE REFERENCED TO THE ABOVE MENTIONED SECTIONS.

MAXIMUM PERCENT OF GRADE	+3.00 %
MINIMUM STOPPING SIGHT DISTANCE	425 FT
DESIGN SPEED	50 MPH
CURRENT ADT	600 VPD
DESIGN ADT (20 YEAR)	700 VPD

THE HOT-MIX ASPHALT SURFACE COURSE, MIX "C", N70 SHALL BE PLACED IN ONE LIFT WITH A MINIMUM THICKNESS OF 1 1/4".

THE QUANTITY SHOWN IN THE SUMMARY OF QUANTITIES FOR HOT-MIX ASPHALT SURFACE COURSE, MIX "C", N70 ALLOWS 142.6 TON FOR THE INTERSECTIONS, SIDEROADS, AND TAPERS; 95.1 TON FOR THE ENTRANCES; 28.4 TON FOR THE MAILBOX TURNOUTS, AND 245.1 TON FOR THE 1 1/4" HOT-MIX ASPHALT SURFACE COURSE, MIX "C", N70.

THE FOLLOWING RATES HAVE BEEN USED TO CALCULATE PLAN QUANTITIES:

AGGREGATE SHOULDERS TY. B	1.8 T / CU YD
HOT-MIX ASPHALT	0.0560 T / SQ YD • INCH
AGGREGATE PRIME COAT	0.001 T / SQ YD
BITUMINOUS MATERIAL (PRIME COAT)	0.05 GAL / SQ YD

SHORT-TERM PAVEMENT MARKINGS SHALL BE PAINTED ON MILLED SURFACES AND TAPED ON LEVEL BINDER AND HOT-MIX SURFACE.

THE QUANTITY SHOWN IN THE SUMMARY OF QUANTITIES FOR GRADING AND SHAPING DITCHES ALLOWS 150 FOOT AT EACH END OF ALL PIPES TO BE REMOVED & RELAY AT STATIONS SHOWN IN SCHEDULE OF REMOVE & RELAY PIPE CULVERTS.

**SUMMARY OF QUANTITIES**

QUANTITY	UNIT	ITEM	CODE NUMBER
150.00	FOOT	GRADING AND SHAPING DITCHES	21400100
1796.00	GALLON	BITUMINOUS MATERIALS (PRIME COAT)	40600100
3685.00	TON	LEVELING BINDER (MACHINE METHOD), N70	40600635
2717.00	TON	HOT-MIX ASPHALT SURFACE COURSE, MIX "C", N70	40603315
1787.00	TON	AGGREGATE SHOULDERS, TYPE B	48101200
18.00	FOOT	PIPE CULVERT REMOVAL (SPECIAL)	X501522S
4.00	FOOT	PIPE CULVERTS, SPECIAL 24"	54205059
14.00	FOOT	PIPE CULVERTS, SPECIAL 30"	54205065
1.00	L SUM	MOBILIZATION	67100100
1.00	L SUM	TRAFFIC CONTROL AND PROTECTION, STANDARD 701306	70100460
1.00	L SUM	TRAFFIC CONTROL AND PROTECTION, STANDARD 701336	70100600
4740.00	FOOT	SHORT-TERM PAVEMENT MARKING	70300100
42248.00	FOOT	PAINT PAVEMENT MARKING-LINE 4"	78001110 *
198.00	EACH	RAISED REFLECTIVE PAVEMENT MARKER	78100100 *
1580.00	FOOT	SHORT-TERM PAVEMENT MARKING REMOVAL	XX003140

\*SPECIALTY ITEMS

**DETAIL OF PRIVATE AND FIELD ENTRANCES**

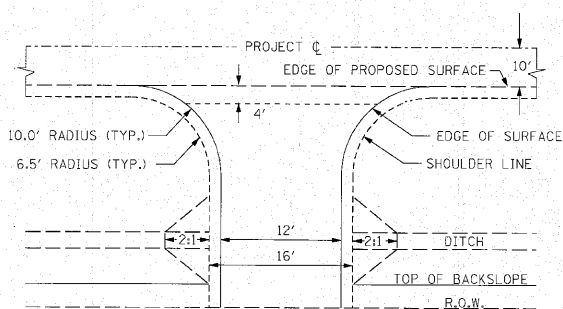

NOTE: THE 4' AREA FROM THE EDGE OF SURFACE, AS SHOWN ABOVE, SHALL BE HOT-MIX ASPHALT SURFACE COURSE, MIX "C", N70 FOR THE PRIVATE ENTRANCES AND THE FIELD ENTRANCES. THIS QUANTITY IS INCLUDED IN THE QUANTITY FOR HOT-MIX ASPHALT SURFACE COURSE, MIX "C", N70.

**PRIVATE & FIELD ENTRANCE APPROACH DETAIL**

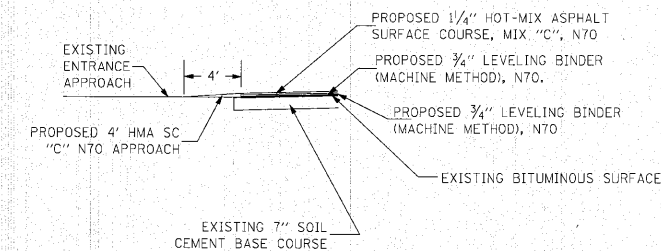

**AGGREGATE SHOULDER DETAIL**

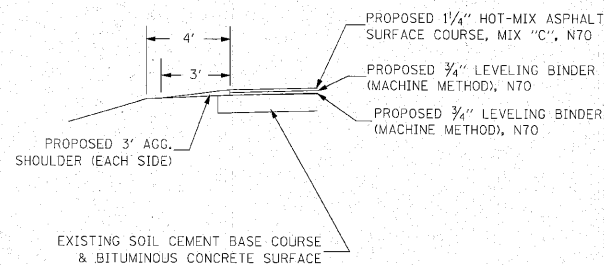

**UTILITIES**

MT. CARMEL PUBLIC UTILITY  
316 MARKET STREET  
MT. CARMEL, IL 62863  
618-262-5151

NORRIS ELECTRIC COOP.  
RT. 130 SOUTH  
NEWTON, IL 62448  
618-299-6101

RURAL WABASH WATER DISTRICT  
P.O. BOX 55  
LANCASTER, IL 62855  
618-665-3311

VERIZON TELEPHONE CO.  
225 EAST CHESTNUT  
ONLEY, IL 62450  
618-395-6181

J.U.L.I.E.  
800-892-0123

323 W. 3RD ST.  
P.O. BOX 160  
MT. CARMEL, IL 62863  
PHONE: (618)-262-8651  
FAX: (618)-263-3327

405 W. STATE ST.  
SUITE 1  
PRINCETON, IN 47570  
PHONE: (812)-386-7611  
FAX: (812)-385-2812



PROFESSIONAL DESIGN FIRM  
LAND SURVEY & PROFESSIONAL ENGINEERING CORPORATION  
184-000887  
(62-032435)(35-002769)



AARON M. MEFFORD  
NAME  
SIGNATURE  
DATE  
10-20-10  
EXPIRES  
11-30-11

DETAILS OF SURFACING AT INTERSECTIONS AND SIDEROADS

F.A.S.	SECTION	COUNTY	TOTAL SHEETS	SHEET NO.
800	07-00075-00-RS	WABASH	4	3
FED. ROAD DIST. NO. 7		ILLINOIS	LANCASTER-FRIENDSVILLE RD	
LEC JOB # H081006WB		CONTRACT # 9594		

DETAIL OF TAPER STA. 0+75 TO STA. 1+25

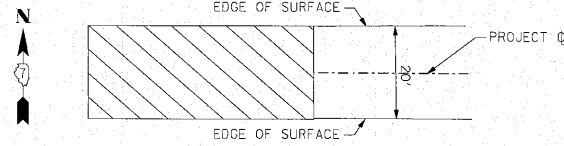

NOTE: THE QUANTITY SHOWN FOR HOT-MIX ASPHALT SURFACE COURSE, MIX "C", N70 INCLUDES 8.7 TONS OF MATERIAL FOR THE TAPER FROM STATION 0+75 TO STATION 1+25.

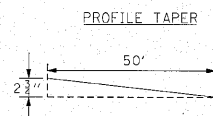

DETAIL OF TAPER STA. 23+40 TO STA. 23+90 & STA. 24+65 TO STA. 25+15

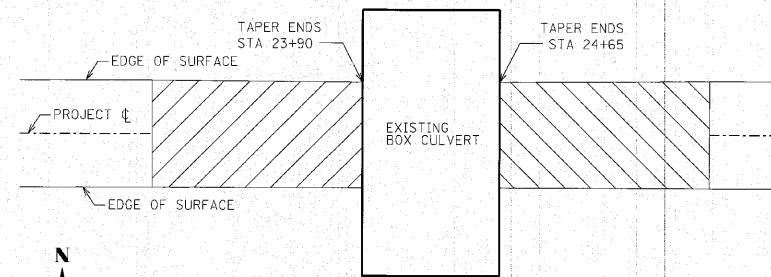

BOX CULVERT TAPER DETAIL  
STA 23+40 TO STA 23+90 & STA 24+65 TO STA 25+15

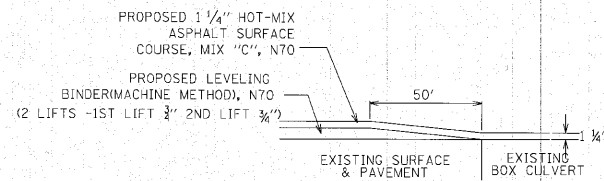

DETAIL OF INTERSECTION 48+50 LT

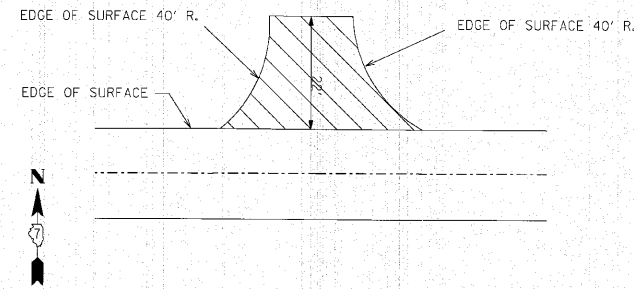

NOTE: THE QUANTITY SHOWN FOR HOT-MIX ASPHALT SURFACE COURSE, MIX "C", N70 INCLUDES 14.4 TONS OF MATERIAL FOR THE SIDEROAD LT

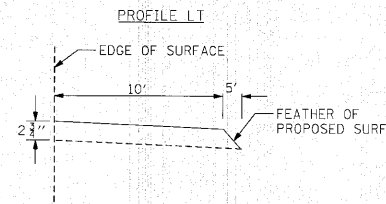

DETAIL OF TAPER STA. 80+15 TO STA. 80+65 & STA. 81+15 TO STA. 81+65

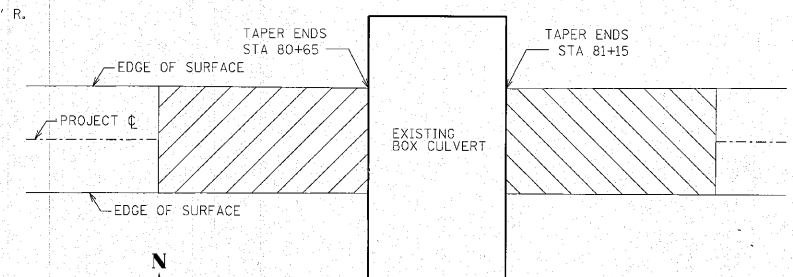

BOX CULVERT TAPER DETAIL  
STA 80+15 TO STA 80+65 & STA 81+15 TO STA 81+65

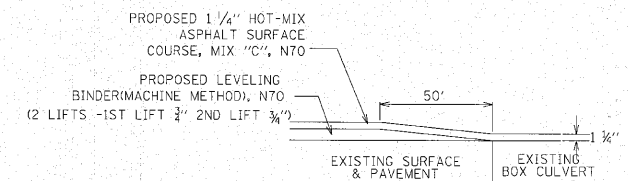

DETAIL OF INTERSECTION 89+80 LT

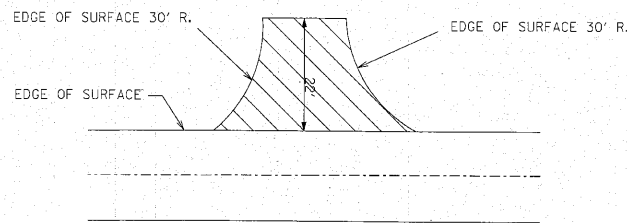

NOTE: THE QUANTITY SHOWN FOR HOT-MIX ASPHALT SURFACE COURSE, MIX "C", N70 INCLUDES 9.5 TONS OF MATERIAL FOR THE SIDEROAD LT.

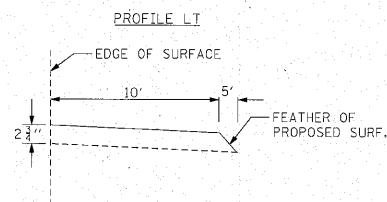

DETAIL OF INTERSECTION 130+50 LT AND RT

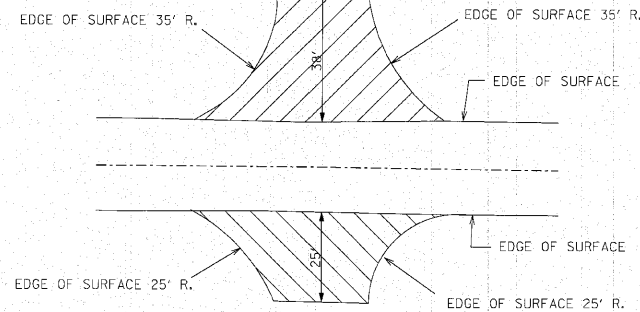

NOTE: THE QUANTITY SHOWN FOR HOT-MIX ASPHALT SURFACE COURSE, MIX "C", N70 INCLUDES 25.5 TONS OF MATERIAL FOR THE SIDEROAD LT APPROACH AND RADII AND 14.1 TONS OF MATERIAL FOR THE SIDEROAD RT. APPROACH AND RADII.

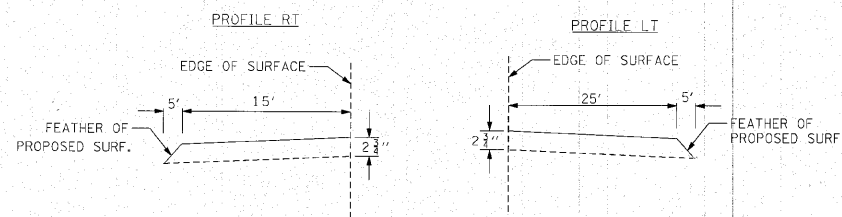

DETAIL OF TAPER STA. 146+10 TO STA. 146+60 & STA. 146+95 TO STA. 147+45

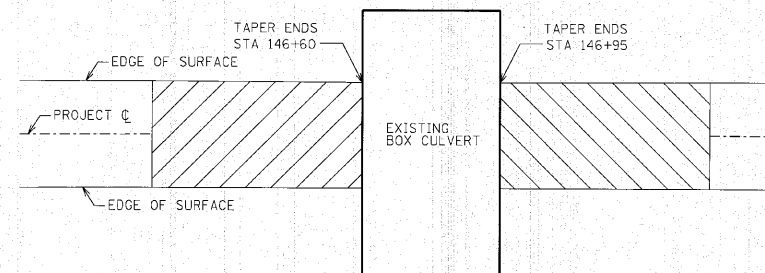

BOX CULVERT TAPER DETAIL  
STA 146+10 TO STA 146+60 & STA 146+95 TO STA 147+45

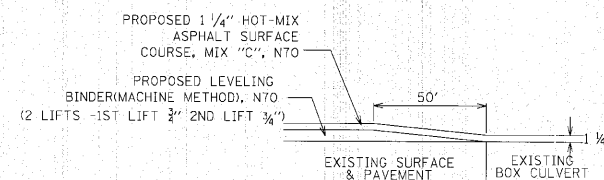

DETAIL OF INTERSECTION 158+02 LT AND RT AND TAPER STA. 158+25 TO STA. 158+75

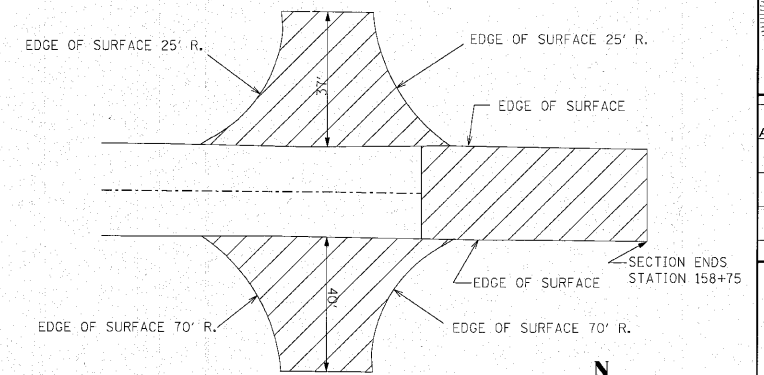

NOTE: THE QUANTITY SHOWN FOR HOT-MIX ASPHALT SURFACE COURSE, MIX "C", N70 INCLUDES 25.0 TONS OF MATERIAL FOR THE SIDEROAD LT APPROACH AND RADII; 36.6 TONS OF MATERIAL FOR THE SIDEROAD RT. APPROACH AND RADII; AND 8.8 TONS OF MATERIAL FOR THE TAPER FROM STATION 158+25 TO STATION 158+75.

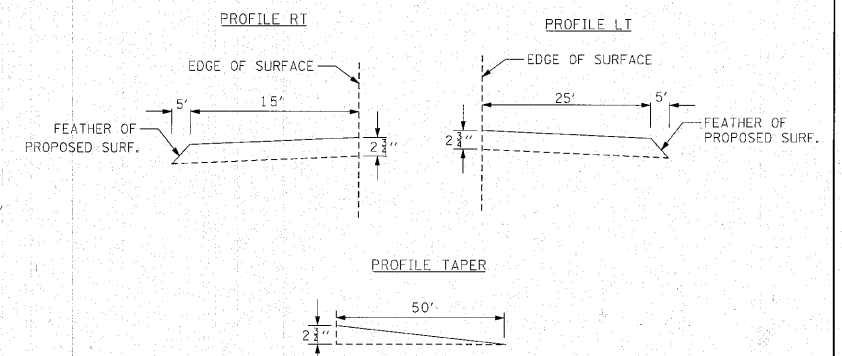

323 W. 3RD ST.  
P.O. BOX 160  
MT. CARMEL, IL  
62863  
PHONE:  
(618)-262-8651  
FAX:  
(618)-263-3327

405 W. STATE ST.  
SUITE 1  
PRINCETON, IN  
47670  
PHONE:  
(812)-386-7611  
FAX:  
(812)-385-2812



PROFESSIONAL DESIGN FIRM  
LAND SURVEY & PROFESSIONAL ENGINEERING CORPORATION  
184-00887  
(62-032435)(35-002769)

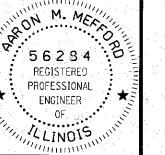

AARON M. MEFFORD  
NAME  
*Aaron M. Mefford*  
SIGNATURE  
10-20-10  
DATE  
11-30-11  
EXPIRES

F.A.S.	SECTION	COUNTY	TOTAL SHEETS	SHEET NO.
800	07-00075-00-NS	WABASH	4	4
FED. ROAD DIST. NO. 7	ILLINOIS	LANCASTER-FRIENDSVILLE RD		
LEC JOB # H081004WB	CONTRACT # 95594			

**SCHEDULE OF PAVEMENT MARKINGS**

STATION	TO	STATION	LOCATION	LENGTH - FOOT
0+75		158+75	CENTERLINE	3638
			EDGELINE	
0+75		130+35	RT.	12960
130+70		157+70	RT.	2700
158+20		158+75	RT.	55
			EDGELINE	
0+75		48+30	LT.	4755
48+70		89+67	LT.	4097
89+94		130+30	LT.	4036
130+70		157+80	LT.	2710
158+20		158+75	LT.	55
			NO PASSING	
0+75		3+70	LT.	295
87+45		93+03	LT.	558
102+96		131+50	RT.	2854
119+00		144+00	LT.	2500
148+40		158+75	RT.	1035
				TOTAL 42,248

THE ABOVE QUANTITY IS SHOW IN THE PAVEMENT MARKING-LINE 4" IN THE SUMMARY OF QUANTITIES.

**SCHEDULE OF PIPE CULVERTS, SPECIAL**

STATION	SIZE	LENGTH	END OF CULVERT
48+65	30"	6'	SOUTH
54+67	30"	8'	NORTH
130+53	24"	4'	NORTH

THE ABOVE QUANTITY IS INCLUDED IN THE PIPE CULVERT REMOVAL (SPECIAL) AND THE PIPE CULVERTS, SPECIAL IN THE SUMMARY OF QUANTITIES.

**SCHEDULE OF MAILBOX TURNOUTS**

STATION	LOCATION	EST. QUANTITY ALLOWED TONS
86+15	RT.	5.0
91+04	RT.	3.7
101+96	RT.	5.0
110+93	RT.	5.0
136+56	LT.	5.9
144+66	LT.	3.8
		TOTAL 28.4

THE ABOVE QUANTITY IS INCLUDED IN THE HOT-MIX ASPHALT SURFACE COURSE, MIX "C", N70 IN THE SUMMARY OF QUANTITIES.

**SCHEDULE OF AGGREGATE SHOULDER STONE IN TANGENT**

STATION	TO	STATION	LOCATION	ALLOWED TONS EST. QUANTITY
0+75		158+75	LT.	758.8
0+75		158+75	RT.	1027.5
				TOTAL 1786.3

THE ABOVE QUANTITY IS FOR THE ENTIRE SECTION AND IS INCLUDED IN THE QUANTITY FOR AGGREGATE SHOULDERS, TYPE B IN THE SUMMARY OF QUANTITIES.

**SCHEDULE OF PRIVATE AND FIELD ENTRANCES**

STATION	LOCATION	BC SC SUPER "C" N50 (IN TONS)
7+19	LT.	2.7
25+08	LT.	2.4
25+09	RT.	3.2
36+06	LT.	2.5
41+22	LT.	2.0
43+48	RT.	2.6
48+55	RT.	1.7
51+22	LT.	2.1
51+23	RT.	2.0
62+12	RT.	2.0
65+56	LT.	2.0
65+57	RT.	2.3
70+38	RT.	2.5
81+76	LT.	2.2
85+39	RT.	3.1
86+78	RT.	1.9
91+23	RT.	2.2
93+23	RT.	3.1
94+07	LT.	3.6
98+38	RT.	2.1
99+48	LT.	3.3

THE ABOVE QUANTITY IS INCLUDED IN THE HOT-MIX ASPHALT SURFACE COURSE, MIX "C", N70 IN THE SUMMARY OF QUANTITIES.

**SCHEDULE OF PRIVATE AND FIELD ENTRANCES**

STATION	LOCATION	BC SC SUPER "C" N50 (IN TONS)
99+48	LT.	3.3
100+16	LT.	2.2
101+05	LT.	5.5
101+25	RT.	2.4
101+98	LT.	3.2
104+42	LT.	2.1
107+91	RT.	2.6
110+25	LT.	1.4
116+87	RT.	1.7
117+56	LT.	1.6
120+55	RT.	1.5
122+84	LT.	1.4
123+88	RT.	2.6
124+68	RT.	1.9
125+36	RT.	1.5
134+58	LT.	1.5
136+36	RT.	2.1
144+40	RT.	1.9
144+41	LT.	1.3
145+55	RT.	1.8
156+82	LT.	3.4
		TOTAL 95.1

323 W. 3RD ST.  
P.O. BOX 160  
MT. CARMEL, IL  
62863  
PHONE:  
(618)-262-8651  
FAX:  
(618)-263-3327

405 W. STATE ST.  
SUITE  
PRINCETON, IN  
47670  
PHONE:  
(812)-386-7811  
FAX:  
(812)-385-2812



PROFESSIONAL DESIGN FIRM  
LAND SURVEY & PROFESSIONAL ENGINEERING CORPORATION  
184-00887  
(62-032435)(35-002769)

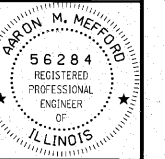

AARON M. MEFFORD  
NAME  
*Aaron Mefford*  
SIGNATURE  
10-26-10  
DATE  
11-30-11  
EXPIRES