

F.A.P. RTE.	SECTION	COUNTY	TOTAL SHEETS	SHEET NO.
353	(12&13)WRS-4	WILL	608	197
STA. 794+84		TO STA. 804+25		
FED. ROAD DIST. NO. 1 ILLINOIS FED. AID PROJECT				

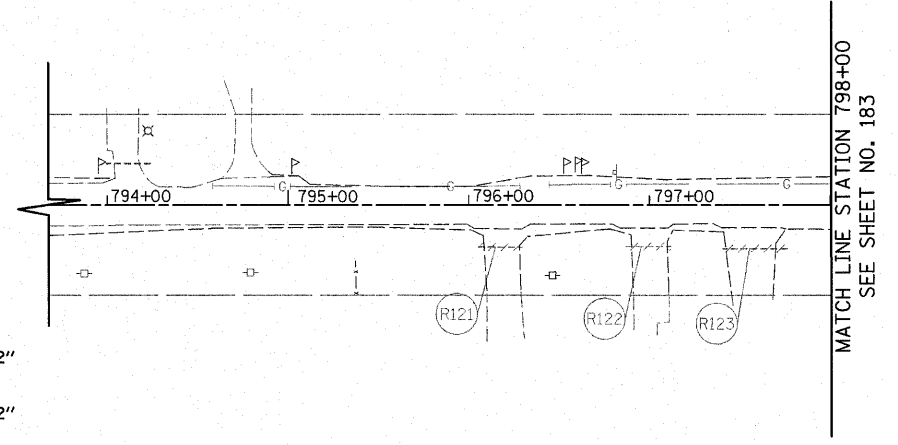

- (R121) 24' STORM SEWER REMOVAL 12" TBF = 1.6 CY
- (R122) 24' STORM SEWER REMOVAL 12" TBF = 2.9 CY
- (R123) 35' STORM SEWER REMOVAL 10" TBF = 4.0 CY
- (R124) 32' STORM SEWER REMOVAL 12" TBF = 3.2 CY
- (R125) 91' STORM SEWER REMOVAL 15" TBF = 7.5 CY
- (R126) 47' STORM SEWER REMOVAL 12" TBF = 0.0 CY

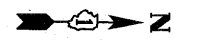
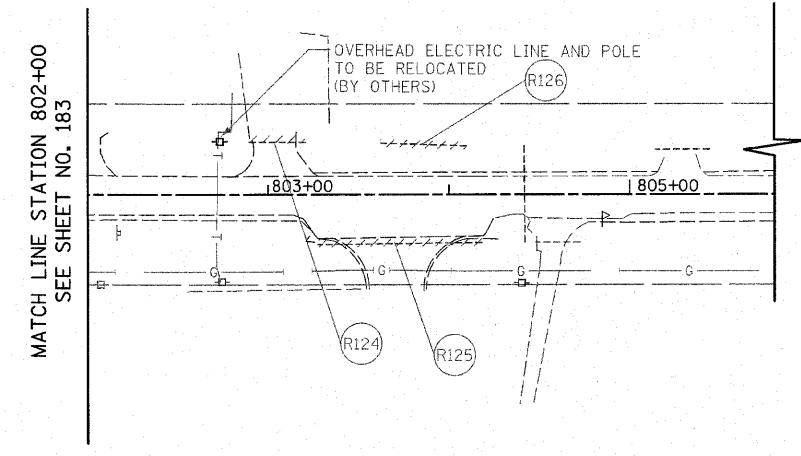

EXISTING 80TH AVENUE

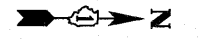

- 497 STA. 795+85.5, 35.0' RT PRC FLARED END SECTION, 15" INV = 719.10
- 498 STA. 796+75, 31.3' RT CB, T-A, 4'-DIA., T-8 GRATE RIM = 719.09 INV = 716.11 (15" N & S)
- 499 STA. 797+25, 35.0' RT CB, T-A, 4'-DIA., T-8 GRATE RIM = 717.70 INV = 714.72 (15" N & S)
- 500 STA. 797+79, 40.6' RT PRC FLARED END SECTION, 15" INV = 713.64
- 501 STA. 797+97, 28.0' LT MH, T-A, 4'-DIA., T-1 FR. CL. RIM = 716.85 INV = 710.79 (12" SE) INV = 708.71 (12" N)
- 502 STA. 797+87, 18.0' LT CB, T-A, 4'-DIA., T-24 F&G RIM = 717.03 INV = 712.87 (12" E) INV = 710.87 (12" NW)
- 503 STA. 797+87, 18.0' RT CB, T-C, T-24 F&G RIM = 717.03 INV = 713.23 (12" W)
- 504 STA. 802+80.35, 34.0' LT PRC FLARED END SECTION, 15" INV = 705.83
- 505 STA. 803+24.35, 34.0' LT PRC FLARED END SECTION, 15" INV = 705.69
- 506 STA. 803+45, 27.4' RT PRC FLARED END SECTION, 18" INV = 706.04
- 507 STA. 804+05, 27.4' RT PRC FLARED END SECTION, 18" INV = 705.77

- (568) 15" SS, CL. A T-2 82' @ 3.40%, TBF = 7.8 CY
- (569) 15" SS, CL. A T-2 46' @ 3.02%, TBF = 8.4 CY
- (570) 15" SS, CL. A T-1 46' @ 2.08%, TBF = 6.4 CY
- (571) 12" SS, CL. A T-2 36' @ 1.00%, TBF = 8.9 CY
- (572) 12" SS, CL. A T-2 8' @ 1.00%, TBF = 0.0 CY
- (573) 15" SS, CL. A T-1 32' @ 0.32%, TBF = 3.5 CY
- (574) 18" SS, CL. A T-1 48' @ 0.45%, TBF = 5.9 CY

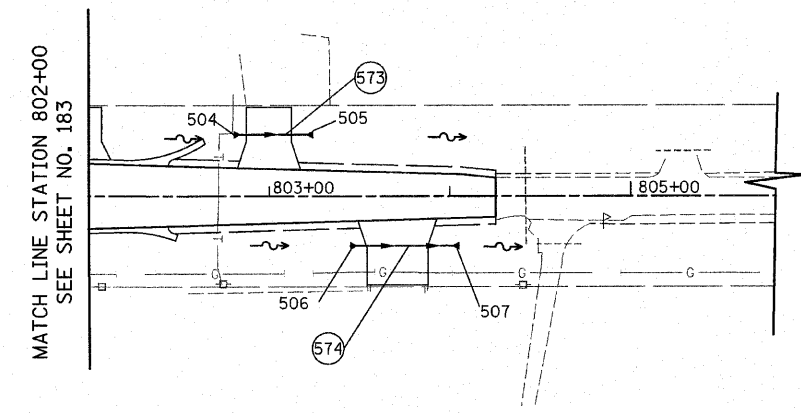
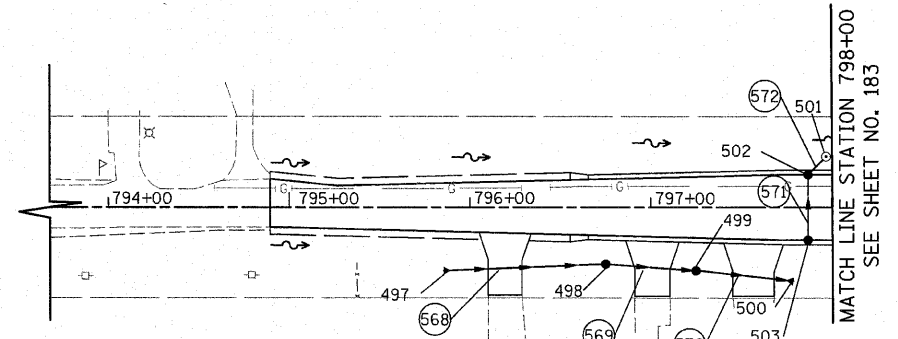

PROPOSED 80TH AVENUE

NOTES:  
1. SEE SHEET NO. 213 FOR CORRESPONDING PROFILE

REVISIONS	
NAME	DATE

ILLINOIS DEPARTMENT OF TRANSPORTATION

80TH AVENUE  
DRAINAGE AND UTILITY PLANS  
STATION 794+84 TO STATION 798+00  
STATION 802+00 TO STATION 804+25

SCALE IN FEET  
0 50

DATE 6/11/2010

DRAWN BY DJK  
CHECKED BY JRV