

F.A.P. RTE.	SECTION	COUNTY	TOTAL SHEETS	SHEET NO.
353	(12&13)WRS-4	WILL	608	72
STA. 794+89.46		TO STA. 804+25.34		
FED. ROAD DIST. NO. 1 ILLINOIS FED. AID PROJECT				

PAVEMENT CORE NO. 18
4.75" BITUMINOUS

PAVEMENT CORE NO. 19
6.5" BITUMINOUS

RESIDENTIAL

COMMERCIAL
STRIP MALL

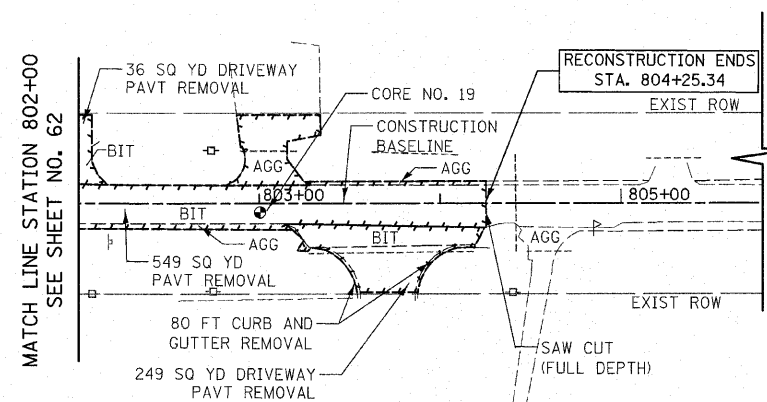
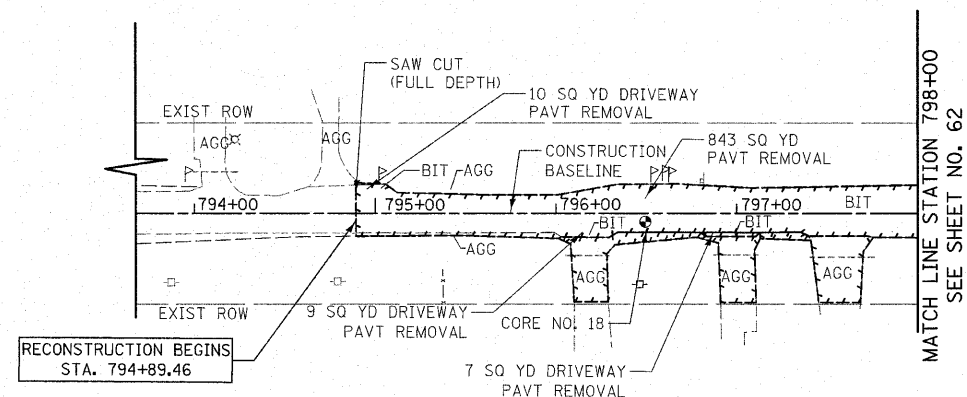

RESIDENTIAL

LINCOLN SQUARE
PLAZA

EXISTING 80TH AVENUE

NOTE:
THE GENERAL CONTRACTOR IS REQUIRED TO HIRE AN ENVIRONMENTAL FIRM WITH AT LEAST FIVE (5) DOCUMENTED LEAKING UNDERGROUND STORAGE TANK (LUST) CLEANUPS OR THAT IS PRE-QUALIFIED IN HAZARDOUS WASTE BY THE DEPARTMENT TO REMEDIATE THE SOIL CONTAMINATION AND MONITOR FOR WORKER PROTECTION.

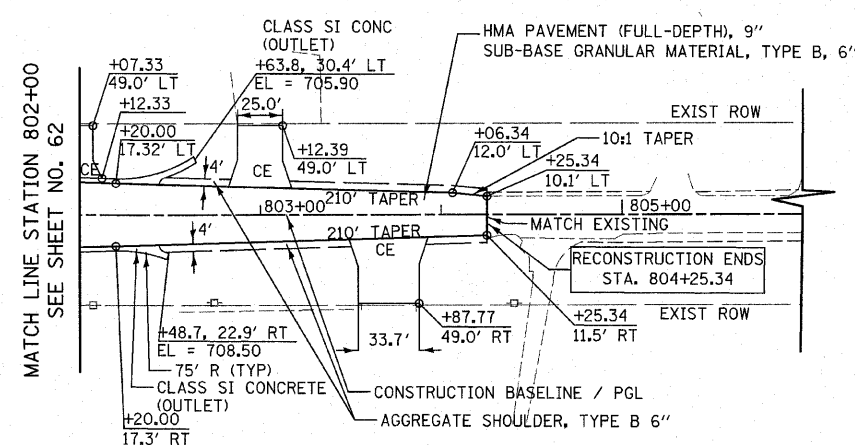
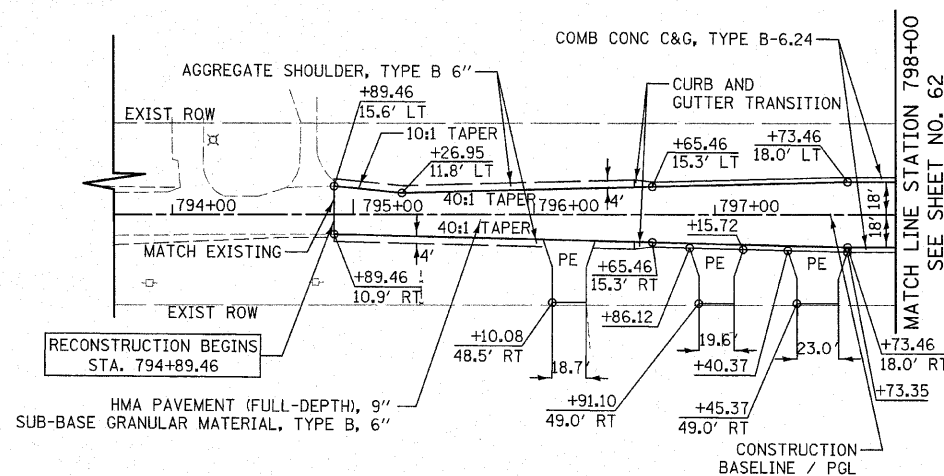

PROPOSED 80TH AVENUE

- ALL DRIVEWAY RADII SHALL BE 15' UNLESS OTHERWISE NOTED. FOR FLARE RATES AND ADDITIONAL DRIVEWAY DETAILS SEE SHEET 496.

REVISIONS	
NAME	DATE

ILLINOIS DEPARTMENT OF TRANSPORTATION

80TH AVENUE
ROADWAY PLANS

STATION 794+89.46 TO STATION 798+00
STATION 802+00 TO STATION 804+25.34

SCALE IN FEET
0 50

DATE 6/11/2010

DRAWN BY DJK
CHECKED BY JRJ