

**BICYCLE RAILING**

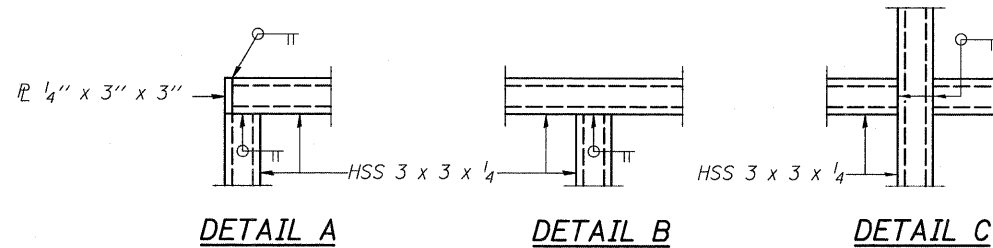

All steel rail elements shall be galvanized according to Article 509.05 of the Standard Specifications.

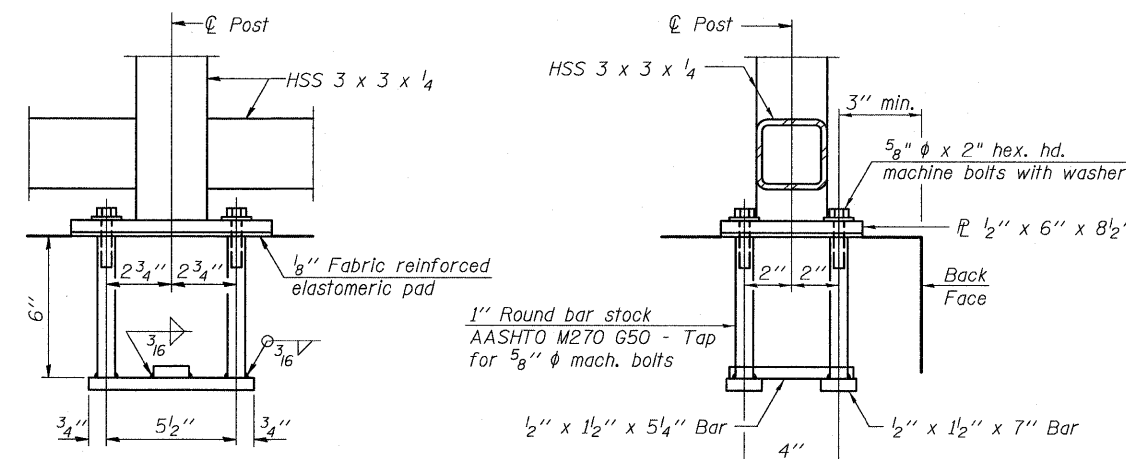
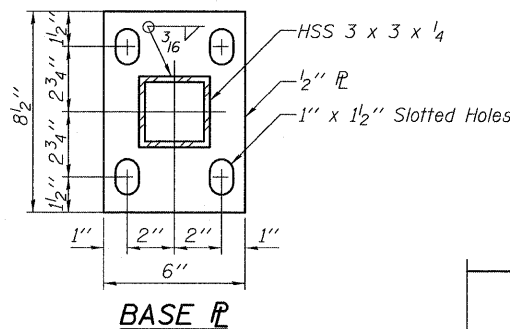
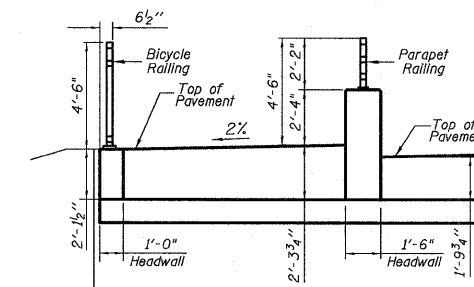

In lieu of the cast-in-place anchor device shown, the Contractor has the option of drilling and setting 5/8" φ anchor rods according to Article 509.06 of the Standard Specifications. Embedment shall be according to the manufacturer's specifications.

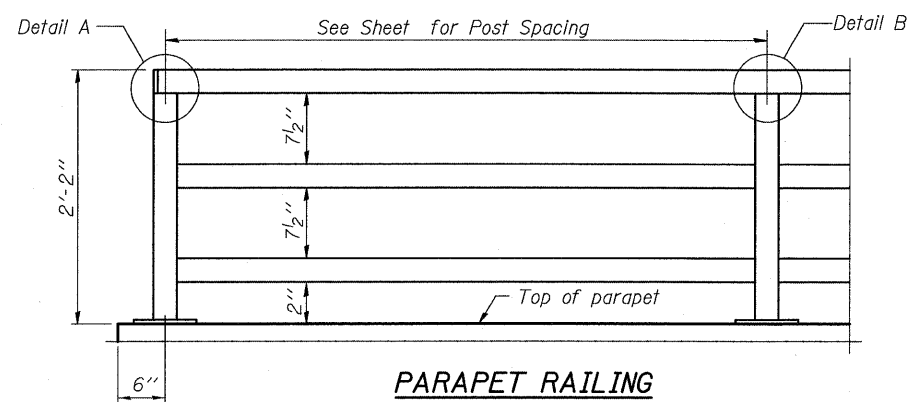

**PARAPET RAILING ELEVATION**

(Inside Face of Three Element Rail)

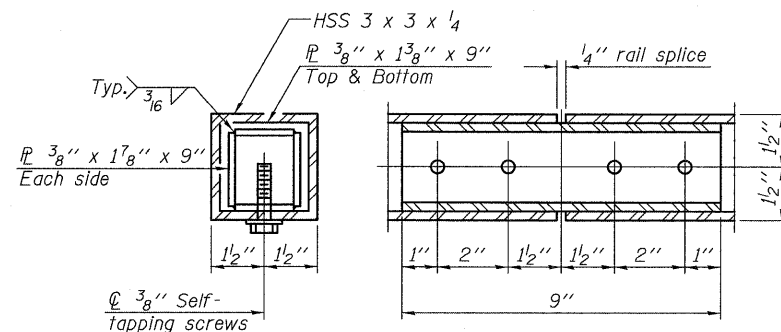

**BILL OF MATERIAL**

Item	Unit	Quantity
Bicycle Railing	Foot	37'-4"
Parapet Railing	Foot	74'-8"

