

STATE OF ILLINOIS
DEPARTMENT OF TRANSPORTATION

ROUTE NO.	SECTION	COUNTY	SHEET	SHEET
FAP 789	54BR-1	MADISON	62	34
FED. ROAD DIST. NO. 7	ILLINOIS	FED. AID PROJECT		

SHEET NO. 10
25 SHEETS

Contract #76864

**SUPERSTRUCTURE
BILL OF MATERIAL**

Bar	No.	Size	Length	Shape
a(E)	1242	#5	19'-1"	—
a ₁ (E)	932	#5	18'-3"	—
a ₂ (E)	1242	#6	6'-0"	—
b(E)	504	#5	34'-4"	—
b ₁ (E)	76	#6	39'-10"	—
b ₂ (E)	76	#6	41'-2"	—
b ₃ (E)	468	#5	31'-11"	—
d(E)	848	#5	3'-0"	—
d ₁ (E)	836	#5	2'-5"	┘
d ₂ (E)	848	#4	3'-0"	—
d ₃ (E)	848	#4	3'-10"	┘
d ₄ (E)	12	#5	2'-2"	┘
e(E)	96	#4	14'-11"	—
e ₁ (E)	96	#4	9'-8"	—
e ₂ (E)	144	#4	15'-2"	—
e ₃ (E)	16	#8	32'-1"	—
e ₄ (E)	32	#8	9'-8"	—
e ₅ (E)	24	#8	32'-7"	—
e ₆ (E)	16	#5	31'-3"	—
e ₇ (E)	32	#5	9'-8"	—
e ₈ (E)	24	#5	31'-9"	—
m(E)	8	#6	18'-4"	—
m ₁ (E)	12	#6	19'-3"	—
m ₂ (E)	24	#6	8'-3"	—
m ₃ (E)	8	#6	6'-3"	—
m ₄ (E)	4	#6	2'-9"	—
m ₅ (E)	4	#6	2'-11"	—
s(E)	76	#5	6'-10"	┘
s ₁ (E)	76	#4	10'-0"	┘
Reinforcement Bars, Epoxy Coated	Pound	116170		
Concrete Superstructure	Cu. Yds.	474.9		

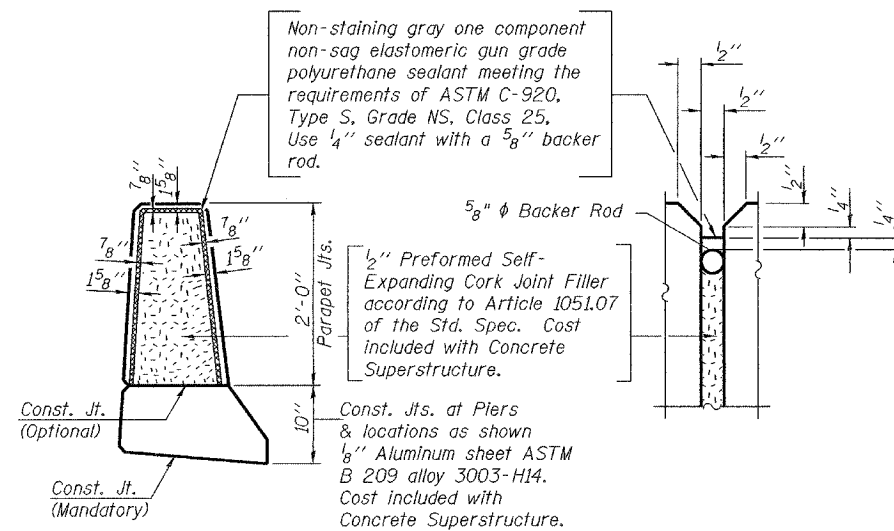

PARAPET JOINT DETAILS

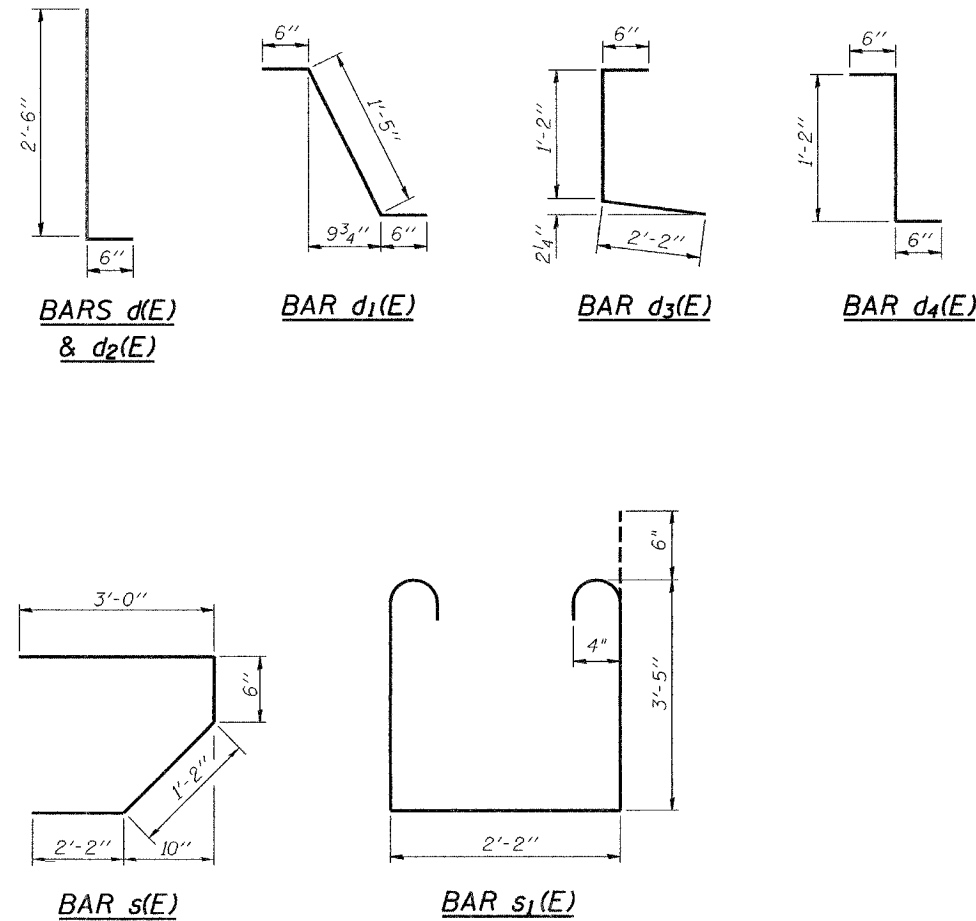

DESIGNED	Curt M. Evoy
CHECKED	Nick R. Barnett
DRAWN	h.t. duong
CHECKED	CME/NRB

EXAMINED	Thomas J. Damagala	Nov. 15, 2006
PASSED	Ralph E. Anderson	

SUPERSTRUCTURE DETAILS
F.A.P. RTE. 789 - SEC. 54BR-1
MADISON COUNTY
STATION 280+73
STRUCTURE NO. 060-0340