

CONSTRUCTION PLANS

REHABILITATE AIRPORT ENTRANCE ROAD (BASE BID)
WITH CONSTRUCT SIDEWALK (ADDITIVE ALTERNATES)

WAUKEGAN PORT DISTRICT
WAUKEGAN NATIONAL AIRPORT (UGN)
WAUKEGAN, LAKE COUNTY, ILLINOIS

IDA PROJECT NO. UGN-4631

LOCATION MAP

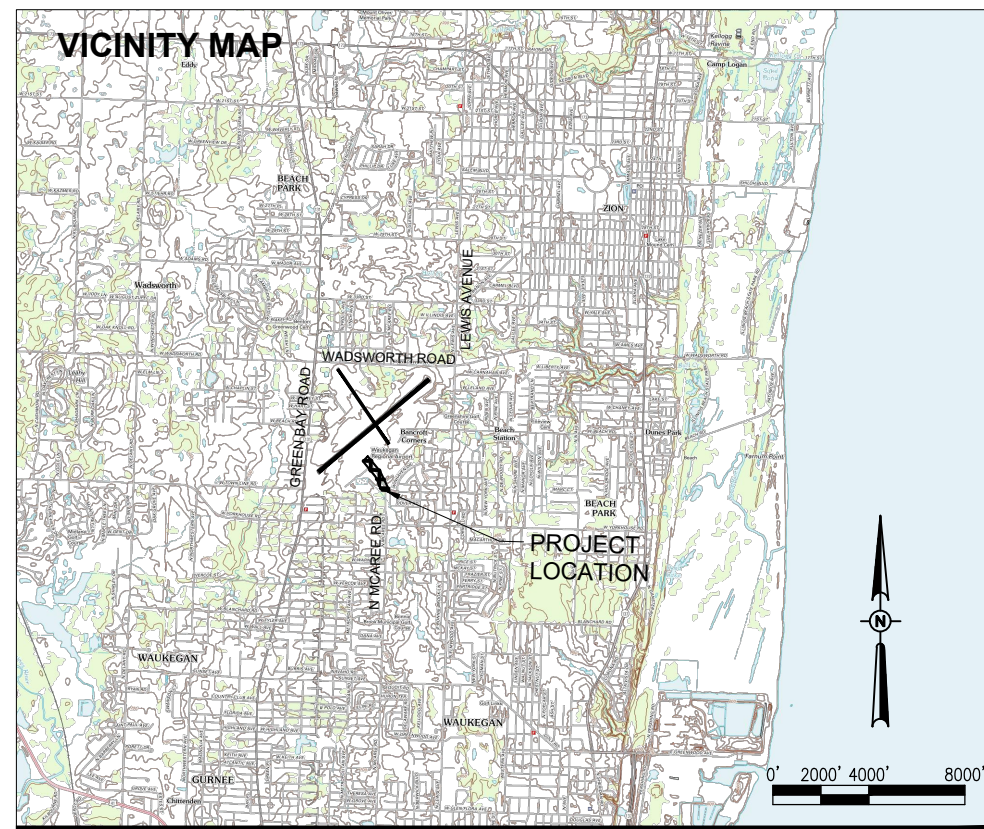
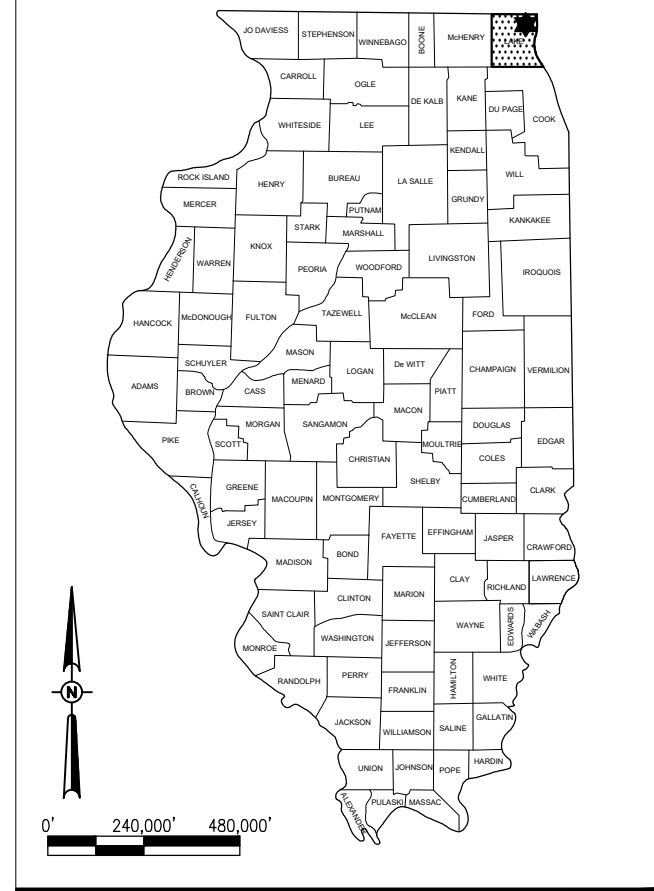

NOTICE TO CONTRACTORS AND BIDDERS

THESE CONSTRUCTION PLANS RELY UPON THE SPECIAL PROVISIONS AND THE SPECIFICATIONS TO PROVIDE FOR A COMPLETE DESCRIPTION OF THE WORK AND CONSTRUCTION REQUIREMENTS. THE PLANS SHALL ONLY BE USED IN COMBINATION WITH ALL CONTRACT DOCUMENTS.

No.	Issue/Description	Sheets Changed	Date	By

Seal

EXP DATE 11/30/19

Lindsay D. Hausman, P.E.,
Project Engineer

Date of Plans

NOVEMBER 16, 2018

Date

HANSON PROFESSIONAL SERVICES INC.
750 Warrenville Road, Suite 200
Lisle, Illinois 60532
Telephone: 630.990.3800
Fax: 630.990.3801

R. M. Hudson

Ronald M. Hudson, AICP
Project Manager

NOVEMBER 16, 2018

Date

WAUKEGAN NATIONAL AIRPORT
WAUKEGAN PORT DISTRICT
2601 Plane Rest Drive
Waukegan, Illinois 60087
Telephone: 847.244.0055
Fax: 847.244.3813

Skip Goss

Skip Goss
Airport Manager

NOVEMBER 16, 2018

Date

Hanson Professional Services Inc.
750 Warrenville Road
Lisle, IL 60532
phone: 630-990-3800
fax: 630-990-3801
Offices Nationwide
www.hanson-inc.com

Illinois Licensed
Professional Service Corporation
#184-001084



WAUKEGAN NATIONAL AIRPORT
WAUKEGAN PORT DISTRICT
2601 Plane Rest Drive
Waukegan, Illinois 60087
Telephone: 847.244.0055
Fax: 847.244.3813

INDEX OF SHEETS

SHEET NO.	TITLE
01	COVER SHEET
02	SHEET INDEX AND SUMMARY OF QUANTITIES
03	SITE PLAN AND GENERAL NOTES
04	CONSTRUCTION SAFETY NOTES & DETAILS
05	CONSTRUCTION SAFETY AND PHASING PLAN - PHASE 1
06	CONSTRUCTION SAFETY AND PHASING PLAN - PHASE 2 & 3
07	TRAFFIC CONTROL STANDARDS
08	TRAFFIC CONTROL STANDARDS
09	TRAFFIC CONTROL STANDARDS
10	TRAFFIC CONTROL STANDARDS
11	TRAFFIC CONTROL STANDARDS
12	ALIGNMENT DATA TABLE & PAVEMENT LAYOUT
13	TYPICAL SECTION AND PAVEMENT DETAILS
14	STORM WATER POLLUTION PREVENTION PLAN
15	STORM WATER POLLUTION PREVENTION PLAN
16	SWPPP DETAILS
17	REMOVAL PLAN
18	REMOVAL PLAN
19	CRACK REPAIR PLAN STA. 1+00 - 4+50
20	CRACK REPAIR PLAN STA. 4+50 - 9+00
21	CRACK REPAIR PLAN STA. 9+00 - 13+00
22	CRACK REPAIR PLAN STA. 13+00 - 17+00
23	PLAN AND PROFILE STA. 0+00 - 4+50
24	PLAN AND PROFILE STA. 4+50 - 9+00
25	PLAN AND PROFILE STA. 9+00 - 14+00
26	PLAN AND PROFILE STA. 14+00 - 19+00
27	CROSS SECTIONS 1+73 TO 4+00
28	CROSS SECTIONS 4+50 TO 7+00
29	CROSS SECTIONS 7+50 TO 10+00
30	CROSS SECTIONS 10+50 TO 13+00
31	CROSS SECTIONS 13+50 TO 16+00
32	CROSS SECTIONS 16+50 TO 17+03
33	DRAINAGE SCHEDULE & DETAILS
34	MARKING PLAN STA. 0+00 - 9+00
35	MARKING PLAN STA. 9+00 - 16+50
36	LANDSCAPING PLAN
37	LANDSCAPING PLAN
38	SIDEWALK AND CURB DETAILS
39	PERPENDICULAR CURB RAMP STANDARDS
40	SIGN PANEL MOUNTING STANDARDS
41	SIGN PANEL ERECTION STANDARDS
42	TELESCOPING STEEL SIGN SUPPORT STANDARDS

SUMMARY OF QUANTITIES

Item No.	Description	Unit	Base Bid	Additive Alternate No. 1	Additive Alternate No. 2	Total
			Quantity	Quantity	Quantity	Quantity
AR150510	ENGINEER'S FIELD OFFICE	LUMP SUM	1.00	0.00	0.00	1.00
AR150520	MOBILIZATION	LUMP SUM	1.00	0.00	0.00	1.00
AR150530	TRAFFIC MAINTENANCE	LUMP SUM	1.00	0.00	0.00	1.00
AR152410	UNCLASSIFIED EXCAVATION	CUBIC YARD	315.00	0.00	0.00	315.00
AR156510	SILT FENCE	LINEAR FOOT	635.00	0.00	0.00	635.00
AR156520	INLET PROTECTION	EACH	3.00	0.00	0.00	3.00
AR156531	EROSION CONTROL BLANKET	SQUARE YARD	2,399.00	0.00	0.00	2,399.00
AR156533	TEMPORARY SEED AND MULCH	ACRE	0.40	0.00	0.00	0.40
AR201661	CLEAN & SEAL BITUMINOUS CRACKS	LINEAR FOOT	664.00	0.00	0.00	664.00
AR201662	BITUMINOUS SAND MIX	SQUARE YARD	1,486.00	0.00	0.00	1,486.00
AR201663	SAND MIX CRACK REPAIR	LINEAR FOOT	212.00	0.00	0.00	212.00
AR201670	CRACK CONTROL FABRIC	SQUARE YARD	1,621.00	0.00	0.00	1,621.00
AR209607	CRUSHED AGG. BASE COURSE-7"	SQUARE YARD	589.00	0.00	0.00	589.00
AR209609	CRUSHED AGG. BASE COURSE-9"	SQUARE YARD	562.00	0.00	0.00	562.00
AR401613	BIT. SURF. CSE. - METHOD I, SUPERPAVE	TON	647.00	0.00	0.00	647.00
AR401650	BITUMINOUS PAVEMENT MILLING	SQUARE YARD	6,158.00	0.00	0.00	6,158.00
AR401660	SAW & SEAL BIT. JOINTS	LINEAR FOOT	366.00	0.00	0.00	366.00
AR401665	BITUMINOUS PAVEMENT SAWING	LINEAR FOOT	3,812.00	0.00	0.00	3,812.00
AR401910	REMOVE & REPLACE BIT. PAVEMENT	SQUARE YARD	13.00	0.00	0.00	13.00
AR602510	BITUMINOUS PRIME COAT	GALLON	177.00	0.00	0.00	177.00
AR603510	BITUMINOUS TACK COAT	GALLON	924.00	0.00	0.00	924.00
AR620535	PAVEMENT MARKING-THERMOPLASTIC	SQUARE FOOT	1,093.00	0.00	0.00	1,093.00
AR751411	INLET-TYPE A	EACH	1.00	0.00	0.00	1.00
AR800905	EDGE REPAIR	SQUARE YARD	90.00	0.00	0.00	90.00
AR800907	INFILTRATION TRENCH	LINEAR FOOT	100.00	0.00	0.00	100.00
AR901510	SEEDING	ACRE	0.60	0.00	0.00	0.60
AR905520	TOPSOILING (FROM OFF SITE)	CUBIC YARD	218.00	0.00	0.00	218.00
AS152410	UNCLASSIFIED EXCAVATION	CUBIC YARD	0.00	120.00	0.00	120.00
AS156531	EROSION CONTROL BLANKET	SQUARE YARD	0.00	3,925.00	0.00	3,925.00
AS156533	TEMPORARY SEED AND MULCH	ACRE	0.00	0.10	0.00	0.10
AS208604	4" AGGREGATE BASE COURSE	SQUARE YARD	0.00	396.00	0.00	396.00
AS501604	4" PCC SIDEWALK	SQUARE FOOT	0.00	3,557.00	0.00	3,557.00
AS620535	PAVEMENT MARKING-THERMOPLASTIC	SQUARE FOOT	0.00	310.00	0.00	310.00
AS754904	REMOVE COMB CURB & GUTTER	LINEAR FOOT	0.00	11.00	0.00	11.00
AS754924	REPLACE COMB CURB & GUTTER	LINEAR FOOT	0.00	11.00	0.00	11.00
AS901510	SEEDING	ACRE	0.00	0.10	0.00	0.10
AS905520	TOPSOILING (FROM OFF SITE)	CUBIC YARD	0.00	52.00	0.00	52.00
AS910200	ROADWAY SIGN	EACH	0.00	7.00	0.00	7.00
AS910915	REMOVE ROADWAY SIGN	EACH	0.00	1.00	0.00	1.00
AT152410	UNCLASSIFIED EXCAVATION	CUBIC YARD	0.00	0.00	80.00	80.00
AT156531	EROSION CONTROL BLANKET	SQUARE YARD	0.00	0.00	2,615.00	2,615.00
AT156533	TEMPORARY SEED AND MULCH	ACRE	0.00	0.00	0.10	0.10
AT208604	4" AGGREGATE BASE COURSE	SQUARE YARD	0.00	0.00	289.00	289.00
AT501604	4" PCC SIDEWALK	SQUARE FOOT	0.00	0.00	2,597.00	2,597.00
AT620535	PAVEMENT MARKING-THERMOPLASTIC	SQUARE FOOT	0.00	0.00	60.00	60.00
AT901510	SEEDING	ACRE	0.00	0.00	0.10	0.10
AT905520	TOPSOILING (FROM OFF SITE)	CUBIC YARD	0.00	0.00	40.00	40.00

PAYMENT WILL BE MADE UNDER THE ITEM NUMBERS, DESCRIPTIONS AND UNITS NOTED IN THE ABOVE TABLE IN ACCORDANCE WITH THE BASIS OF PAYMENT FOR EACH RESPECTIVE WORK ITEM NOTED IN THE SPECIAL PROVISIONS, COMPLETED AND ACCEPTED BY THE ENGINEER.

* THE WORK QUANTITIES FOR AR201661 CLEAN AND SEAL BITUMINOUS CRACKS AND AR201663 SAND MIX CRACK REPAIR ASSUME THAT 90 PERCENT OF THE TYPE A CRACKS AND 50 PERCENT OF THE TYPE B CRACKS ARE ELIMINATED DURING THE 2 INCH SURFACE REMOVAL UNDER ITEM AR401650. THE ACTUAL LOCATION AND QUANTITY OF CRACKS TO BE REPAIRED SHALL BE DETERMINED BY THE RESIDENT ENGINEER AFTER MILLING OPERATIONS. CONTRACTOR SHALL PERFORM THE WORK AS DIRECTED BY THE RESIDENT ENGINEER AND SHALL NOT BE ENTITLED TO OR MAKE ANY CLAIM FOR ADDITIONAL COMPENSATION IF THE ACTUAL QUANTITY PERFORMED IS MORE OR LESS THAN THE BID QUANTITY ESTIMATED FOR EACH REPAIR ITEM.

REHABILITATE AIRPORT
ENTRANCE ROAD (BASE BID)
WITH CONSTRUCT SIDEWALK
(ADDITIVE ALTERNATES)

IDA No: UGN-4631

WA073

MARK	DATE	DESCRIPTION		
		DES	DRN	REV

ISSUE:
PROJECT NO: 17A0077
CAD FILE: 02-SQ.DWG
DESIGN BY: LDH
DRAWN BY: SCS
REVIEWED BY: KMS 10/17/18

SHEET TITLE

SHEET INDEX AND
SUMMARY OF
QUANTITIES

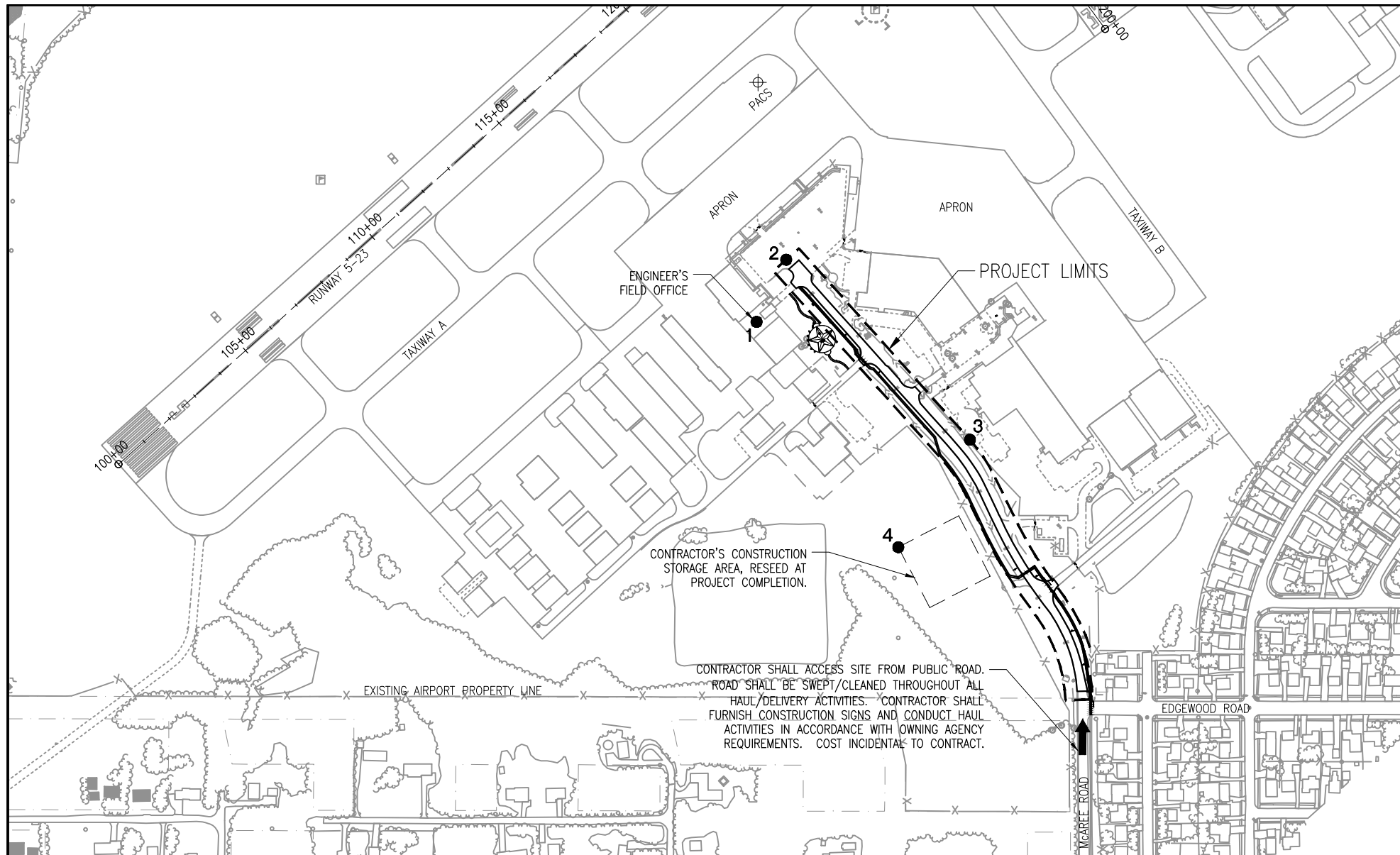

GENERAL NOTES

PROJECT DESCRIPTION

THIS PROJECT IS TO REHABILITATE THE AIRPORT ENTRANCE ROAD (MCAREE RD) AT WAUKEGAN NATIONAL AIRPORT INCLUDING. THIS AIRPORT ENTRANCE ROAD PROJECT INCLUDES THE BASE BID AND ADDITIVE ALTERNATES NO. 1 AND NO. 2. AWARD WILL BE MADE PER THE BID PROPOSAL. WORK INCLUDED IS:

BASE BID

- PLACEMENT OF TEMPORARY EROSION CONTROL MEASURES.
- MILLING OF BITUMINOUS (HMA) PAVEMENT.
- PAVEMENT REPLACEMENT AND CRACK REPAIR.
- PROVISION OF REQUIRED UNCLASSIFIED EXCAVATION.
- INSTALLATION OF AGGREGATES AND BITUMINOUS (HMA) OVERLAY AND SHOULDER.
- PLACEMENT OF PAVEMENT MARKINGS.
- TOPSOILING, SEEDING AND EROSION CONTROL BLANKET IN ALL DISTURBED AREAS, INCLUDING ALONG NEW PAVEMENT EDGES.

ADDITIVE ALTERNATE NO.1

- CONSTRUCT PCC SIDEWALK, WITH UNCLASSIFIED EXCAVATION, PCC SIDEWALK AND CURB AND GUTTER CONSTRUCTION, ROAD SIGNAGE, TOPSOILING, AND SEEDING/BLANKET.

ADDITIVE ALTERNATE NO.2

- CONSTRUCT PCC SIDEWALK, WITH UNCLASSIFIED EXCAVATION, PCC SIDEWALK CONSTRUCTION, TOPSOILING, AND SEEDING/BLANKET.

PROTECTION OF EXISTING AIRPORT FACILITIES

THE CONTRACTOR IS TO BE RESPONSIBLE FOR THE PROTECTION OF EXISTING UNDERGROUND AND OVERHEAD UTILITIES AND LIGHTING EQUIPMENT; DRIVEWAY AND ROAD PAVEMENT AND SHOULDERS; RUNWAY, TAXIWAY AND APRON PAVEMENTS AND SHOULDERS; RUNWAY, TAXIWAY AND AIRPORT LIGHTING EQUIPMENT; AND SEEDED AND TURFED AREAS THAT ARE UTILIZED IN OR AFFECTED BY THE CONTRACTOR'S ACTIVITIES. ITEMS DAMAGED BY THE CONTRACTOR ARE TO BE REPAIRED AT CONTRACTOR'S EXPENSE AND TO THE SATISFACTION OF AIRPORT MANAGER AND THE OWNER'S REPRESENTATIVE.

IN ADDITION, WHEN CONDITIONS DICTATE OR AS DETERMINED BY THE AIRPORT MANAGER OR THE OWNER'S REPRESENTATIVE, THE CONTRACTOR SHALL BE REQUIRED TO USE A PICK-UP TYPE SWEEPER IN ALL ACTIVE CONSTRUCTION AIRFIELD PAVEMENT AREAS. THE CONTRACTOR WILL BE REQUIRED TO HAVE A SWEEPER AVAILABLE FOR USE AT ALL TIMES. THE COST OF SWEEPING SHALL BE CONSIDERED INCIDENTAL TO THE CONTRACT.

EXISTING CONTROL POINTS

PACS:	N 2095587.482	SACS 1	N 2098251.587	SACS 2	N 2096854.703
	E 1109729.492		E 1112341.241		E 1110827.340
	ELEV. 705.1		ELEV. 717.6		ELEV. 709.1
			(NOT SHOWN)		(NOT SHOWN)

CONTRACTOR'S ACCESS AND TEMPORARY FACILITIES

CONTRACTOR'S ACCESS TO THE PROJECT WHEN ON AIRPORT PROPERTY IS SHOWN ON THIS SHEET. CONTRACTOR'S ACCESS TO THE AIRPORT ITSELF IS TO BE PROVIDED BY PUBLIC RIGHTS-OF-WAY. THE CONTRACTOR IS TO SECURE ALL NECESSARY PERMITS FOR THE USE OF ANY PUBLIC RIGHTS-OF-WAY AND IS TO MAINTAIN TRAFFIC ON THESE PUBLIC ROADS AT ALL TIMES, WITH THE COSTS OF PERMITTING, CLEANING AND REPAIRING OF PAVEMENT DAMAGED BY CONTRACTOR'S ACTIVITIES INCIDENTAL TO THE CONTRACT. USE OF AND REPAIRS TO ANY PUBLIC FACILITIES ARE TO BE COMPLETED TO THE SATISFACTION OF THE FACILITY'S OWNER.

THE CONTRACTOR IS TO PROVIDE TEMPORARY CONSTRUCTION ROADS WITHIN THE CONSTRUCTION LIMIT LINES AS MAY BE REQUIRED BY HIS ACTIVITIES. HEAVY VEHICLES SHALL NOT CROSS EXISTING PAVEMENT SURFACES EXCEPT AS APPROVED BY THE AIRPORT MANAGER AND THE OWNER'S REPRESENTATIVE. ANY DAMAGE TO PAVEMENTS THAT MAY OCCUR BY THE CONTRACTOR'S ACTIVITIES SHALL BE REPAIRED AT THE CONTRACTOR'S EXPENSE AND TO THE SATISFACTION OF THE AIRPORT MANAGER AND THE OWNER'S REPRESENTATIVE. FOR HAUL ROUTES MADE BY CONTRACTOR THROUGH GRASSED AREAS, CONTRACTOR SHALL GRADE, LEVEL, TOPSOIL, SEED AND MULCH AT THE END OF THE PROJECT, COST INCIDENTAL TO THE CONTRACT.

THE CONTRACTOR IS TO PROVIDE AN EQUIPMENT STORAGE AND PARKING AREA AT THE LOCATIONS SHOWN ON THIS SHEET. IT IS THE CONTRACTOR'S RESPONSIBILITY TO MAINTAIN THE ACCESS ROADS AND THE STORAGE AREA DURING CONSTRUCTION AND TO RESTORE THE AREAS AT PROJECT COMPLETION TO CONDITIONS SUITABLE TO THE AIRPORT MANAGER AND THE OWNER'S REPRESENTATIVE. AT THE AIRPORT MANAGER'S DISCRETION, THE TEMPORARY FACILITIES MAY REMAIN, BUT THEY MUST BE LEFT IN CONDITIONS SUITABLE TO THE AIRPORT MANAGER. THE COST OF PROVIDING, MAINTAINING AND RESTORING THE TEMPORARY FACILITIES IS INCIDENTAL TO THE CONTRACT.

RESPONSIBILITY FOR EXISTING UTILITIES

THE LOCATION, SIZE AND/OR TYPE OF MATERIAL OF EXISTING UNDERGROUND OR OVERHEAD UTILITIES AS MAY BE INDICATED ON THESE CONSTRUCTION PLANS IS NOT REPRESENTED AS BEING ACCURATE, SUFFICIENT OR COMPLETE. NEITHER THE OWNER NOR THE PROJECT ENGINEER HAVE INDEPENDENTLY VERIFIED THIS INFORMATION AND NEITHER ASSUMES ANY RESPONSIBILITY WHATSOEVER IN RESPECT TO THE ACCURACY, SUFFICIENCY OR COMPLETENESS OF THE INFORMATION AND GIVE NO EXPRESSED OR IMPLIED GUARANTEE THAT ANY CONDITIONS INDICATED ARE REPRESENTATIVE OF ACTUAL CONDITIONS TO BE ENCOUNTERED.

IT SHALL BE THE CONTRACTOR'S RESPONSIBILITY TO DETERMINE THE ACTUAL LOCATION OF ALL SUCH FACILITIES, INCLUDING SERVICE CONNECTIONS TO UNDERGROUND UTILITIES. PRIOR TO CONSTRUCTION, THE CONTRACTOR SHALL NOTIFY ALL UTILITY COMPANIES AND AGENCIES OF HIS CONSTRUCTION PLANS AND SHALL OBTAIN FROM EACH PARTY DETAILED INFORMATION AND ASSISTANCE RELATIVE TO THE LOCATION OF ALL UTILITIES AND THE WORKING SCHEDULE OF ANY REMOVALS OR ADJUSTMENTS REQUIRED OF THE UTILITY. THE CONTRACTOR SHALL CONTACT J.U.L.I.E. (PHONE 800-892-0123) TO ASSIST IN THE ABOVE.

THE CONTRACTOR SHALL PROTECT ANY FACILITIES TO THE SATISFACTION OF THE UTILITY OR OWNING-AGENCY WITH THE COST OF ANY REQUIRED PROTECTION TO BE INCIDENTAL TO THE CONTRACT. IN THE EVENT A UTILITY LINE OR SERVICE IS UNEXPECTEDLY ENCOUNTERED DURING CONSTRUCTION, THE CONTRACTOR SHALL IMMEDIATELY NOTIFY THE OWNER'S REPRESENTATIVE AND THE UTILITY COMPANY OR AGENCY OF JURISDICTION. ANY SUCH UTILITIES DISTURBED BY THE CONTRACTOR'S OPERATIONS SHALL BE RESTORED TO SERVICE AT ONCE.

CONTRACTOR SHALL ACCESS SITE FROM PUBLIC ROAD. ROAD SHALL BE SWEEP/CLEANED THROUGHOUT ALL HAUL/DELIVERY ACTIVITIES. CONTRACTOR SHALL FURNISH CONSTRUCTION SIGNS AND CONDUCT HAUL ACTIVITIES IN ACCORDANCE WITH OWNING AGENCY REQUIREMENTS. COST INCIDENTAL TO CONTRACT.

CONTRACTOR'S CONSTRUCTION STORAGE AREA, RESEED AT PROJECT COMPLETION.

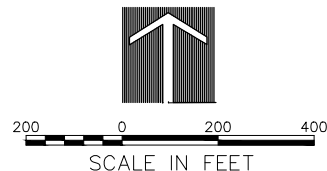

PROJECT IS LOCATED IN
SOUTHEAST 1/4 OF SECTION
31, BENTON TOWNSHIP, LAKE
COUNTY

RUNWAY END COORDINATES				
DESCRIPTION	LATITUDE	LONGITUDE	STATION	ELEVATION
RUNWAY 5 END	42° 24' 57.07" N	87° 52' 32.19" W	100+00.00	724.7
RUNWAY 23 END	42° 25' 36.37" N	87° 51' 32.33" W	159+98.75	723.1
RUNWAY 14 END	42° 25' 39.58" N	87° 52' 22.73" W	237+49.94	727.8
RUNWAY 14 END	42° 25' 35.65" N	87° 52' 18.90" W	232+59.41	727.6
RUNWAY 32 END	42° 25' 09.54" N	87° 51' 53.48" W	200+00.00	712.1

NOTES:

1. WORK MUST BE CONTROLLED.
2. MAXIMUM HEIGHT OF CONTRACTOR'S EQUIPMENT 25 FEET FOR ALL WORK, EXCEPT BY PRIOR APPROVAL OF THE ENGINEER (SEE SPECIAL PROVISIONS).
3. TRAFFIC TO BE MAINTAINED ON ALL AIRPORT ROADWAYS AT ALL TIMES.
4. FOR PHASING INFORMATION, SEE PHASING PLAN.

POINT INFORMATION - PERMANENT OBJECTS

POINT NO.	DESCRIPTION	MOBILITY	GROUND ELEVATION	OBJECT ELEVATION	LATITUDE	LONGITUDE	RUNWAY 5-23 STATION	RUNWAY 5-23 OFFSET	RUNWAY 5-23 EXIST EL.	RUNWAY 14-32 STATION	RUNWAY 14-32 OFFSET	RUNWAY 14-32 EXIST EL.
1	ENGINEER'S FIELD OFFICE	STATIONARY	705.2	720.2	42° 25' 01.0970" N	87° 52' 07.1904" W	116+73.51	938.6	711.1	199+08.37	1333.6	712.1
2	CONSTRUCTION EQUIPMENT	MOBILE	706.4	731.4	42° 25' 02.8949" N	87° 52' 06.0180" W	118+60.04	860.7	710.7	200+04.57	1155.9	712.1
3	CONSTRUCTION EQUIPMENT	MOBILE	705.7	730.7	42° 24' 57.6458" N	87° 51' 58.8667" W	119+09.07	1614.2	710.5	192+59.82	1031.6	712.1
4	CONSTRUCTION EQUIPMENT	STATIONARY	704.3	729.3	42° 24' 54.5401" N	87° 52' 01.6925" W	115+41.91	1708.9	711.3	191+28.77	1387.4	712.1

REHABILITATE AIRPORT ENTRANCE ROAD (BASE BID) WITH CONSTRUCT SIDEWALK (ADDITIVE ALTERNATES)

IDA No: UGN-4631

WA073

MARK	DATE	DESCRIPTION		
		DES	DRN	REV

ISSUE:

PROJECT NO: 17A0077
CAD FILE: 03-SP& NOTES.DWG
DESIGN BY: LDH
DRAWN BY: SCS
REVIEWED BY: KMS 10/17/18

SHEET TITLE

SITE PLAN AND GENERAL NOTES

Hanson Professional Services Inc.
750 Warrenville Road
Lisle, IL 60532
phone: 630-990-3800
fax: 630-990-3801
Offices Nationwide
www.hanson-inc.com

Illinois Licensed
Professional Service Corporation
#184-001084



WAUKEGAN NATIONAL AIRPORT
WAUKEGAN PORT DISTRICT
2601 Plane Rest Drive
Waukegan, Illinois 60087
Telephone: 847.244.0055
Fax: 847.244.3813

CONSTRUCTION SAFETY AND PHASING PLAN NOTES

SAFETY IS REQUIRED

CONSTRUCTION OF THE PROJECT SHALL BE PERFORMED IN ACCORDANCE WITH THE GUIDELINES SPECIFIED IN FAA ADVISORY CIRCULAR 150/5320-2 (CURRENT ISSUE) AND THE AIRPORT VEHICLE OPERATIONS REGULATIONS (SEE WAUKEGAN NATIONAL AIRPORT'S WEBSITE AT <http://waukeganairport.com/wp-content/uploads/Ground-Vehicle-Ops-Training.pdf>). ANY CONTRACTOR ACTIVITIES REQUIRED FOR PROJECT SAFETY SHALL BE PROVIDED BY THE CONTRACTOR AND INCIDENTAL TO THE CONTRACT. THE CONTRACTOR SHALL MAINTAIN A COPY OF FAA ADVISORY CIRCULAR 150/5370-2F, CURRENT ISSUE, AND THE KUGN AIRPORT VEHICLE OPERATIONS REGULATIONS AT THE PROJECT SITE AT ALL TIMES.

PRIOR TO THE ISSUANCE OF A CONSTRUCTION NOTICE-TO-PROCEED (NTP) BY THE ILLINOIS DIVISION OF AERONAUTICS, THE CONTRACTOR SHALL PREPARE AND SUBMIT A SAFETY PLAN COMPLIANCE DOCUMENT (SPCD) IN ACCORDANCE WITH FAA ADVISORY CIRCULAR 150/5370-2F, PARAGRAPH 204B, OR EQUIVALENT SECTION IN SUBSEQUENT/CURRENT ISSUES. THE SPCD SHALL BE REVIEWED AND APPROVED BY THE AIRPORT MANAGER, WHO WILL THEN SUBMIT THE DOCUMENT TO THE ILLINOIS DIVISION OF AERONAUTICS FOR THEIR APPROVAL PRIOR TO NOTICE TO PROCEED.

SEQUENCE OF CONSTRUCTION

TO MINIMIZE DISRUPTIONS TO AIRPORT OPERATIONS, CONSTRUCTION OPERATIONS MUST BE CONTROLLED THROUGHOUT THE PROJECT'S DURATION, AND WORK MUST BE COMPLETED EXPEDITIOUSLY. A CONSTRUCTION PHASING PLAN DETAILING THE SEQUENCING OF THE CONTRACTOR'S WORK THROUGHOUT THE PROJECT IS INCLUDED IN THE PLANS. THE CONTRACTOR SHALL PROVIDE HIS WRITTEN ACCEPTANCE OF THE PROJECT CONSTRUCTION SAFETY AND PHASING PLAN AT THE PRE-CONSTRUCTION CONFERENCE. ANY AND ALL CHANGES TO THE CONSTRUCTION SAFETY AND PHASING PLAN THAT MAY BE REQUESTED BY THE CONTRACTOR MUST BE APPROVED BY THE PROJECT ENGINEER AND THE AIRPORT OWNER. IT SHALL BE THE CONTRACTOR'S RESPONSIBILITY TO PROVIDE SUFFICIENT ADVANCE NOTICE OF ANY PROPOSED PHASING CHANGE TO PERMIT CONSIDERATION AND APPROVAL BY THE PROJECT ENGINEER AND THE AIRPORT OWNER. THE CONTRACTOR SHALL NOT BE ENTITLED TO ANY EXTRA COMPENSATION NOR EXTENSION TO THE CONTRACT TIME BECAUSE OF A PHASING CHANGE REQUEST NOR FOR ANY TIME NECESSARY IN RECEIVING THE REQUIRED APPROVALS. THE CONTRACTOR SHALL EXPEDITE WORK AT THOSE PHASES WHEN ACTIVE RUNWAYS, TAXIWAYS, HANGAR ACCESS, APRONS, ROADWAYS OR PARKING LOTS MUST BE CLOSED, TO MINIMIZE THE LENGTH OF TIME THAT AIRPORT OPERATIONS ARE RESTRICTED.

AT THE PRE-CONSTRUCTION CONFERENCE, THE CONTRACTOR SHALL PROVIDE A "CONTRACTOR COORDINATION PLAN" THAT COORDINATES HIS WORK WITH THE WORK OF HIS SUBCONTRACTORS AND THE WORK OF OTHER CONTRACTORS OF OTHER ON-GOING AIRPORT PROJECTS.

CONSTRUCTION LIMITS

THE CONTRACTOR SHALL REMAIN WITHIN THE CONSTRUCTION LIMITS SHOWN ON THE PLANS. THE CONTRACTOR SHALL FURNISH MEASURES TO PREVENT EQUIPMENT AND PERSONNEL FROM OPERATING OUTSIDE THESE LIMITS.

TEMPORARY BARRICADES ON AIRFIELD

THE PROJECT WILL REQUIRE THE PLACEMENT OF BARRICADES TO DELINEATE PORTIONS OF THE CONSTRUCTION AREA. SINCE THE WORK WILL BE LIMITED TO THE ROADWAY, STANDARD IDOT TRAFFIC CONTROL MEASURES WILL BE REQUIRED. WHENEVER WORKING WITHIN THE PROPOSED CONSTRUCTION AREAS, IT WILL BE THE CONTRACTOR'S RESPONSIBILITY TO PLACE BARRICADES AND OTHER CONTROL DEVICES AS SHOWN IN THE PLANS AND AS DIRECTED BY THE RESIDENT ENGINEER. THE COST OF THESE ITEMS, AND THEIR MAINTENANCE, IS TO BE PAID UNDER ITEM AR150530 TRAFFIC MAINTENANCE. NO RUNWAY, TAXIWAY OR APRON CLOSURES WILL BE ALLOWED AS PART OF THIS PROJECT.

VEHICULAR TRAFFIC CONTROL

CONTRACTOR ACCESS TO THE PROJECT WHEN ON AIRPORT PROPERTY IS SHOWN IN THE PLANS. CONTRACTOR'S ACCESS TO THE AIRPORT ITSELF IS TO BE PROVIDED BY RIGHTS-OF-WAY. THE CONTRACTOR IS TO SECURE ALL NECESSARY PERMITS FOR THE USE OF ANY PUBLIC RIGHTS-OF-WAY AND IS TO MAINTAIN TRAFFIC ON THESE PUBLIC ROADS AT ALL TIMES, WITH THE COSTS OF PERMITTING, CLEANING AND REPAIRING OF PAVEMENT DAMAGED BY THE CONTRACTOR'S ACTIVITIES INCIDENTAL TO THE CONTRACT. USE OF AND REPAIRS TO ANY PUBLIC FACILITIES ARE TO BE COMPLETED TO THE SATISFACTION OF THE FACILITY'S OWNER.

THE CONTRACTOR IS TO PROVIDE TEMPORARY CONSTRUCTION ROADS WITHIN THE CONSTRUCTION LIMIT LINES AS MAY BE REQUIRED BY HIS ACTIVITIES. THE CONTRACTOR MAY MAKE USE OF ANY EXISTING HAUL ROUTES WITHIN THE PROJECT LIMITS, BUT SHALL REPAIR/MAINTAIN SAME DURING CONSTRUCTION, AND SHALL REMOVE THE EXISTING HAUL ROUTES AT PROJECT END, IF DIRECTED BY THE RESIDENT ENGINEER. HEAVY VEHICLES SHALL NOT CROSS EXISTING PAVEMENT SURFACES EXCEPT AS APPROVED BY THE AIRPORT OWNER AND THE RESIDENT ENGINEER. ANY DAMAGE TO PAVEMENTS THAT MAY OCCUR BY THE CONTRACTOR'S ACTIVITIES SHALL BE REPAIRED AT THE CONTRACTOR'S EXPENSE AND TO THE SATISFACTION OF THE AIRPORT OWNER AND THE RESIDENT ENGINEER. FOR HAUL ROUTES MADE BY THE CONTRACTOR THROUGH GRASSED AREAS OR EXISTING HAULS USED BY THE CONTRACTOR, CONTRACTOR SHALL REMOVE, GRADE LEVEL TOPSOIL SEED AND MULCH AT THE END OF THE PROJECT; COST INCIDENTAL TO THE CONTRACT.

CONTRACTOR IS TO PROVIDE AN EQUIPMENT STORAGE AND PARKING AREA AT THE LOCATIONS SHOWN IN THE PLANS. IT IS THE CONTRACTOR'S RESPONSIBILITY TO MAINTAIN ACCESS ROADS AND THE STORAGE AREA DURING CONSTRUCTION AND TO RESTORE AREAS AT PROJECT COMPLETION TO CONDITIONS SUITABLE TO THE AIRPORT OWNER AND THE RESIDENT ENGINEER. AT THE AIRPORT OWNER'S DISCRETION, THE TEMPORARY FACILITIES MAY REMAIN, BUT THEY MUST BE LEFT IN CONDITIONS SUITABLE TO THE AIRPORT OWNER. THE COST OF PROVIDING, MAINTAINING AND RESTORING THE TEMPORARY FACILITIES IS INCIDENTAL TO THE CONTRACT.

THE CONTRACTOR SHALL ERECT AND MAINTAIN, AT NO COST TO THE CONTRACT, DIRECTIONAL AND INFORMATIONAL SIGNS FOR THE CONTRACTOR'S ACCESS ROUTES AT THE EXISTING CONSTRUCTION ENTRANCES AND FOR THE CONTRACTOR'S ROUTE WITHIN THE AIRPORT OPERATIONS AREA, AS NOTED ON THE PLANS OR AS DIRECTED BY THE RESIDENT ENGINEER.

IT SHALL BE THE CONTRACTOR'S RESPONSIBILITY TO PROVIDE AND PLACE ROAD WARNING SIGNS AND BARRICADES ON THE EXISTING ROADWAYS PRIOR TO THE START OF CONSTRUCTION IN THE VICINITY. THE CONTRACTOR SHALL PROVIDE, INSTALL AND RELOCATE THE ITEMS AS REQUIRED. THE COST OF THIS WORK IS TO BE PAID UNDER TRAFFIC MAINTENANCE, AR150530.

CONTRACTOR SHALL PROVIDE, INSTALL AND REMOVE ALL TRAFFIC CONTROL ITEMS WHEN CONSTRUCTION ACTIVITIES ARE WITHIN 15 FEET OF AN ACTIVE ROADWAY EDGE OR AS REQUIRED BY THE SITE PLAN. COST OF THIS WORK IS TO BE PAID UNDER TRAFFIC MAINTENANCE, AR150530.

AIRFIELD OPERATIONAL SAFETY DURING CONSTRUCTION

THE CONTRACTOR SHALL NOT HAVE ACCESS TO ANY PART OF THE ACTIVE AIRFIELD (RUNWAYS, TAXIWAYS OR APRONS) FOR ANY EQUIPMENT OR PERSONNEL WITHOUT THE APPROVAL OF THE RESIDENT ENGINEER AND THE AIRPORT OWNER. ACTIVITIES WITHIN THE AIRPORT OPERATIONS AREA (AOA) ARE SUBJECT TO FORMAL ACCESS CONTROL. BECAUSE OF THE HIGH REQUIREMENTS FOR AIRPORT SECURITY AND SAFETY, THE FOLLOWING REQUIREMENTS MUST BE ADHERED TO:

- ALL EMPLOYEES OF THE CONTRACTOR SHALL PARK THEIR PERSONAL VEHICLES IN THE DESIGNATED EQUIPMENT PARKING AND STORAGE AREA. EACH PERSON OR VEHICLE ENTERING THE CONTRACTOR AREA SHALL DO SO IN ACCORDANCE WITH THE POLICIES AND PROCEDURES OF THE AIRPORT OWNER. THE CONTRACTOR WILL TRANSPORT THE WORKERS FROM THE PARKING AREAS TO THE WORK AREA. ONLY CONTRACTOR VEHICLES WILL BE ALLOWED OUTSIDE OF THE PROPOSED EQUIPMENT STORAGE AND PARKING AREAS.
- SHOULD ANY CONTRACTOR PERSONNEL BE IDENTIFIED AS NONCOMPLIANT WITH ANY VEHICLE DRIVING SAFETY REQUIREMENTS IN THIS PROJECT SAFETY PLAN OR IN THE AIRPORT VEHICLE OPERATIONS REGULATIONS, SUCH DRIVERS SHALL BE PENALIZED BY RESCISSION OF THEIR ON-AIRPORT DRIVING PRIVILEGES, AND THEIR ACCESS TO THE CONSTRUCTION LIMIT AREA WHEN OPERATING VEHICLES SHALL BE REVOKED.
- THE CONTRACTOR WILL BE REQUIRED TO BE IN TWO-WAY RADIO CONTACT WITH THE WAUKEGAN AIR TRAFFIC CONTROL TOWER GROUND CONTROL (121.65 MHZ) WHENEVER HIS WORK ENTERS THE AIRPORT OPERATIONS AREA (AOA). THIS WILL KEEP THE CONTRACTOR IN CONSTANT CONTACT WITH FAA PERSONNEL AND ENABLE THE FAA PERSONNEL TO IMMEDIATELY CONTACT THE CONTRACTOR IN CASE OF AN AERONAUTICAL EMERGENCY THAT WOULD REQUIRE ACTION BY THE CONTRACTOR AND/OR HIS PERSONNEL. THE PROVISION OF RADIO EQUIPMENT BY THE CONTRACTOR FOR THIS PURPOSE SHALL BE INCIDENTAL TO THE CONTRACT.
- THE CONTRACTOR SHALL COORDINATE GATE SECURITY, THROUGH THE RESIDENT ENGINEER, WITH THE AIRPORT OWNER. AIRPORT SECURITY SHALL BE MAINTAINED AT ALL TIMES.

THE CONTRACTOR SHALL REMAIN WITHIN THE CONSTRUCTION LIMITS LINE SHOWN IN THE PLANS. WHEN OUTSIDE THE CONSTRUCTION LIMITS LINE, ALL CONTRACTOR ACTIVITIES SHALL REMAIN MORE THAN 200 FEET FROM THE CENTERLINE AND 300 FEET FROM THE END OF ACTIVE RUNWAY 14-32, AND 250 FEET FROM THE CENTERLINE AND 1,000 FEET FROM THE END OF ACTIVE RUNWAY 5-23. FOR WORK NEAR TAXIWAYS AND APRONS, THE CONTRACTOR'S PERSONNEL AND EQUIPMENT MUST REMAIN AT LEAST 44.5 FEET FROM ACTIVE CATEGORY I TAXIWAYS, 65.5 FEET FROM ACTIVE CATEGORY II TAXIWAY CENTERLINES, AND 93 FEET FROM ACTIVE CATEGORY III TAXIWAY CENTERLINES, 44.5 FEET FROM ACTIVE T-HANGAR TAXILANE CENTERLINES, AND TEN (10) FEET FROM ACTIVE APRON EDGES. WHEN CONSTRUCTION OPERATIONS MUST BE CONDUCTED WITHIN THESE SEPARATIONS, THE PAVEMENT MUST BE CLOSED TO AIRCRAFT ACTIVITY BY THE CONTRACTOR BY PROVIDING TEMPORARY BARRICADES AS SHOWN IN THE PLANS, AND IN THE CASE OF RUNWAY PAVEMENTS, CLOSED RUNWAY MARKERS. NO CLOSURE OF ANY RUNWAY WILL BE PERMITTED FOR THIS PROJECT, EXCEPT AS NOTED ELSEWHERE IN THIS PARAGRAPH.

THE PROJECT DOES NOT INCLUDE THE CLOSING OF ANY RUNWAY, TAXIWAY, APRON, OR OTHER AIRPORT PAVEMENTS AT ANY TIME DURING THE PROJECT. SHOULD THE CONTRACTOR REQUEST, AND THE AIRPORT OWNER AGREE TO ANY PAVEMENT CLOSING, THE FOLLOWING SHALL APPLY:

- SUCH CLOSING SHALL HAVE BEEN PRIOR APPROVED THROUGH THE SUBMITTAL AND APPROVAL OF A REVISED CONSTRUCTION SAFETY AND PHASING PLAN.
- FOR RUNWAYS, THE CONTRACTOR SHALL, AT HIS EXPENSE, PLACE, OPERATE, AND MAINTAIN THE LIGHTED RUNWAY CLOSURE MARKERS FURNISHED BY THE AIRPORT OWNER, AS DETAILED IN THE PLANS.
- TO MINIMIZE DISRUPTION TO AIRCRAFT OPERATIONS ASSOCIATED WITH THE RUNWAY CLOSURE, CONSTRUCTION WORK MUST BE COMPLETED EXPEDITIOUSLY. RUNWAY CLOSINGS SHALL ONLY BE PERMITTED BY PRIOR AUTHORIZATION OF THE RESIDENT ENGINEER AND THE AIRPORT OWNER, AND IN ACCORDANCE WITH THE REVISED CONSTRUCTION SAFETY AND PHASING PLAN.
- THE CONTRACTOR, AT HIS EXPENSE, SHALL FURNISH, PLACE, MAINTAIN, RELOCATE, AND REMOVE TEMPORARY BARRICADES ON AIRFIELD RUNWAYS, TAXIWAYS, AND OTHER PAVEMENTS SURFACES AS SHOWN AND DETAILED IN THE CONSTRUCTION PLANS, OR AS DIRECTED BY THE RESIDENT ENGINEER.
- WHEN THE RUNWAY IS TO BE CLOSED, THE AIRPORT OWNER WILL DE-ENERGIZE AIRPORT/RUNWAY NAVAIDS, AND AIRFIELD LIGHTING POWER AND CONTROL CIRCUITS WHEN REQUIRED BY THE CONTRACTOR'S ACTIVITIES. THE CONTRACTOR SHALL NOT PROCEED WITH FURTHER WORK UNTIL AFTER THE REQUIRED CHANGES TO THE AIRPORT POWER AND CONTROL CIRCUITS HAVE BEEN MADE BY THE AIRPORT OWNER.

THE CONTRACTOR SHALL KEEP ALL OF HIS EQUIPMENT AND PERSONNEL AT LEAST 15 FEET FROM THE EDGE OF ANY ACTIVE ROADWAY OR AUTO PARKING PAVEMENT. WHEN HIS ACTIVITIES REQUIRE WORKING WITHIN 15 FEET OF THE ROAD/PAVEMENT EDGE, THE CONTRACTOR SHALL PROVIDE FOR TRAFFIC CONTROL IN ACCORDANCE WITH IDOT SPECIFICATIONS (HIGHWAY STANDARDS).

OPEN TRENCHES, EXCAVATIONS AND STOCKPILED MATERIAL AT THE CONSTRUCTION SITE SHALL BE DELINEATED WITH THE USE OF BARRICADES DURING HOURS OF RESTRICTED VISIBILITY AND/OR DARKNESS. NO OPEN TRENCHES SHALL BE ALLOWED WITHIN THE RUNWAY SAFETY AREA (RSA) OR THE TAXIWAY SAFETY AREA (TSA) WHEN THE RUNWAY OR TAXIWAY IS OPEN TO AIR TRAFFIC (INCLUDING OVERNIGHT). THE RSA IS DEFINED AS 75 FEET FROM THE CENTERLINE AND 300 FEET FROM THE END OF RUNWAY 14-32, AND 250 FEET FROM THE CENTERLINE AND 1,000 FEET FROM THE END OF RUNWAY 5-23. THE TSA IS MEASURED AT 24.5 FEET FROM THE CATEGORY I TAXIWAY CENTERLINE, 39.5 FEET FROM THE CATEGORY II TAXIWAY CENTERLINE, AND 59 FEET FROM THE CATEGORY III TAXIWAY CENTERLINE, AND 24.5 FEET FROM THE T-HANGAR TAXILANE CENTERLINE. NO VERTICAL DROP OF GREATER THAN 3-INCHES IN HEIGHT FROM PAVEMENT EDGE TO EARTH GRADE OR EARTH GRADE TO EARTH GRADE WITHIN THE RSA OR TSA WILL BE PERMITTED WHEN THE RUNWAY OR TAXIWAY IS OPEN TO AIR TRAFFIC. THE CONTRACTOR WILL HAVE STEEL PLATES ON-SITE TO ALLOW FOR THE RAPID COVERING OF TRENCHES OR EARTH DROPS IN THE EVENT OF UNEXPECTED WORK STOPPAGES FOR WEATHER OR AIRPORT EMERGENCIES.

WHEN NOT IN USE AND DURING NONWORKING HOURS, CONTRACTOR'S EQUIPMENT SHALL BE PARKED WITHIN THE CONTRACTOR'S EQUIPMENT STORAGE AND PARKING AREAS. THE EQUIPMENT STORAGE AND PARKING AREAS ARE TO BE LOCATED AS SHOWN ON THE CONSTRUCTION SAFETY AND PHASING PLAN. THE CONTRACTOR WILL BE RESPONSIBLE FOR MAINTAINING THE CONSTRUCTION ENTRANCE IN GOOD CONDITION. THE COST OF MAINTAINING THE CONSTRUCTION ENTRANCE IS TO BE INCIDENTAL TO THE CONTRACT. THE CONTRACTOR SHALL PROTECT ALL EXISTING PAVEMENT EDGES FROM DAMAGE FROM CONSTRUCTION EQUIPMENT AND HAUL VEHICLES.

AT NO TIME SHALL THE CONTRACTOR OPERATE OR PARK EQUIPMENT SO AS TO OBSTRUCT AN ACTIVE RUNWAY APPROACH SURFACE.

BEFORE REOPENING ROADWAYS, THE CONTRACTOR SHALL INSPECT AND CLEAN, AS NECESSARY, THE PAVEMENT TO ASSURE THAT NO MATERIALS OR OBJECTS THAT MAY DAMAGE AIRCRAFT OR VEHICLES REMAIN. ANY REQUIRED CLEANING SHALL BE TO THE SATISFACTION OF THE RESIDENT ENGINEER AND AIRPORT OWNER AND IS INCIDENTAL TO THE CONTRACT.

CONTRACTOR'S EQUIPMENT SHALL EXTEND NO HIGHER THAN 25 FEET. CRANES SHALL NOT BE USED DURING INSTRUMENT WEATHER CONDITIONS OR AT NIGHT. CRANES SHALL BE LOWERED WHEN NOT IN USE.

ALL WORK SHALL BE COMPLETED IN ACCORDANCE WITH THE APPROVED PROJECT SAFETY PLAN, ISSUED BY THE ILLINOIS DIVISION OF AERONAUTICS.

FAILURE TO USE THESE PRESCRIBED PROCEDURES OR ADHERE TO THE SAFETY REQUIREMENTS WILL RESULT IN THE SUSPENSION OF WORK.

NOTIFICATIONS BY CONTRACTOR

THE CONTRACTOR MUST NOTIFY THE RESIDENT ENGINEER AND THE AIRPORT OWNER THREE (3) DAYS IN ADVANCE OF ANY REQUIRED PARTIAL OR COMPLETE CLOSING OF ANY TAXIWAY OR APRON. THE DATE, TIME AND SCHEDULED DURATION OF THE CLOSING MUST BE APPROVED BY THE RESIDENT ENGINEER AND THE AIRPORT OWNER. THE CONTRACTOR SHALL NOTIFY THE RESIDENT ENGINEER AND AIRPORT OWNER THREE (3) DAYS IN ADVANCE OF THE CONTRACTOR'S CLOSING OF OTHER ACTIVE ROADWAYS, AIRFIELD OR ROADWAY LIGHTING CIRCUITS, OR OTHER AIRPORT FACILITIES.

CONTRACTOR'S USE OF SITE

AT NO TIME SHALL THE CONTRACTOR CONDUCT ANY ACTIVITIES OR OPERATE OR PARK EQUIPMENT SO AS TO OBSTRUCT ACTIVE PART 77 AIRPORT IMAGINARY SURFACES. WORK WITHIN THE RUNWAY PROTECTION ZONE (RPZ), AS DELINEATED IN THE PLANS, SHALL ONLY BE PERMITTED AS FOLLOWS.

- ALL WORK SHALL BE LIMITED TO THOSE AREAS WITHIN THE CONSTRUCTION LIMIT LINE SHOWN ON THE CONSTRUCTION SAFETY AND PHASING PLAN, INCLUDING ALL MEN, EQUIPMENT, AND MATERIALS/HAUL VEHICLES.
- START OF ANY WORK SHALL BE PREVIOUSLY NOTIFIED AND PRIOR APPROVED BY THE RESIDENT ENGINEER AND THE AIRPORT OWNER.

THE CONTRACTOR IS RESPONSIBLE FOR RESTORATION OF THE WORK AREA PRIOR TO BEGINNING WORK AT A NEW LOCATION.

UTILITY OUTAGES AND SHUTDOWNS

THE CONTRACTOR SHALL PROVIDE 72 HOURS PRIOR NOTICE OF ANY OUTAGES OR SHUTDOWNS TO THE OWNER AND THE AGENCY OWNING THE AFFECTED UTILITY. THE CONTRACTOR SHALL PROVIDE ANY TEMPORARY CONNECTIONS OR OTHER MEASURES AS MAY BE REQUIRED TO MAINTAIN SERVICE AS MAY BE REQUIRED BY THE OWNING AGENCY AT NO COST TO THE OWNER.

ALL NOTES AND DETAILS SHOWN ON THE CONSTRUCTION SAFETY AND PHASING PLAN ARE APPLICABLE TO THIS PROJECT.

ALL WORK SHALL BE COMPLETED IN ACCORDANCE WITH THE APPROVED PROJECT CONSTRUCTION AND PHASING PLAN, ISSUED BY THE ILLINOIS DIVISION OF AERONAUTICS. FAILURE TO USE THESE PRESCRIBED PROCEDURES OR ADHERE TO THE SAFETY REQUIREMENTS WILL RESULT IN THE SUSPENSION OF WORK.

REHABILITATE AIRPORT
ENTRANCE ROAD (BASE BID)
WITH CONSTRUCT SIDEWALK
(ADDITIVE ALTERNATES)

IDA No: UGN-4631

WA073

MARK	DATE	DESCRIPTION		
		DES	DRN	REV

ISSUE:

PROJECT NO: 17A0077
CAD FILE: 04-SAFNOTES.DWG
DESIGN BY: LDH
DRAWN BY: SCS
REVIEWED BY: KMS 10/17/18

SHEET TITLE

CONSTRUCTION
SAFETY NOTES &
DETAILS

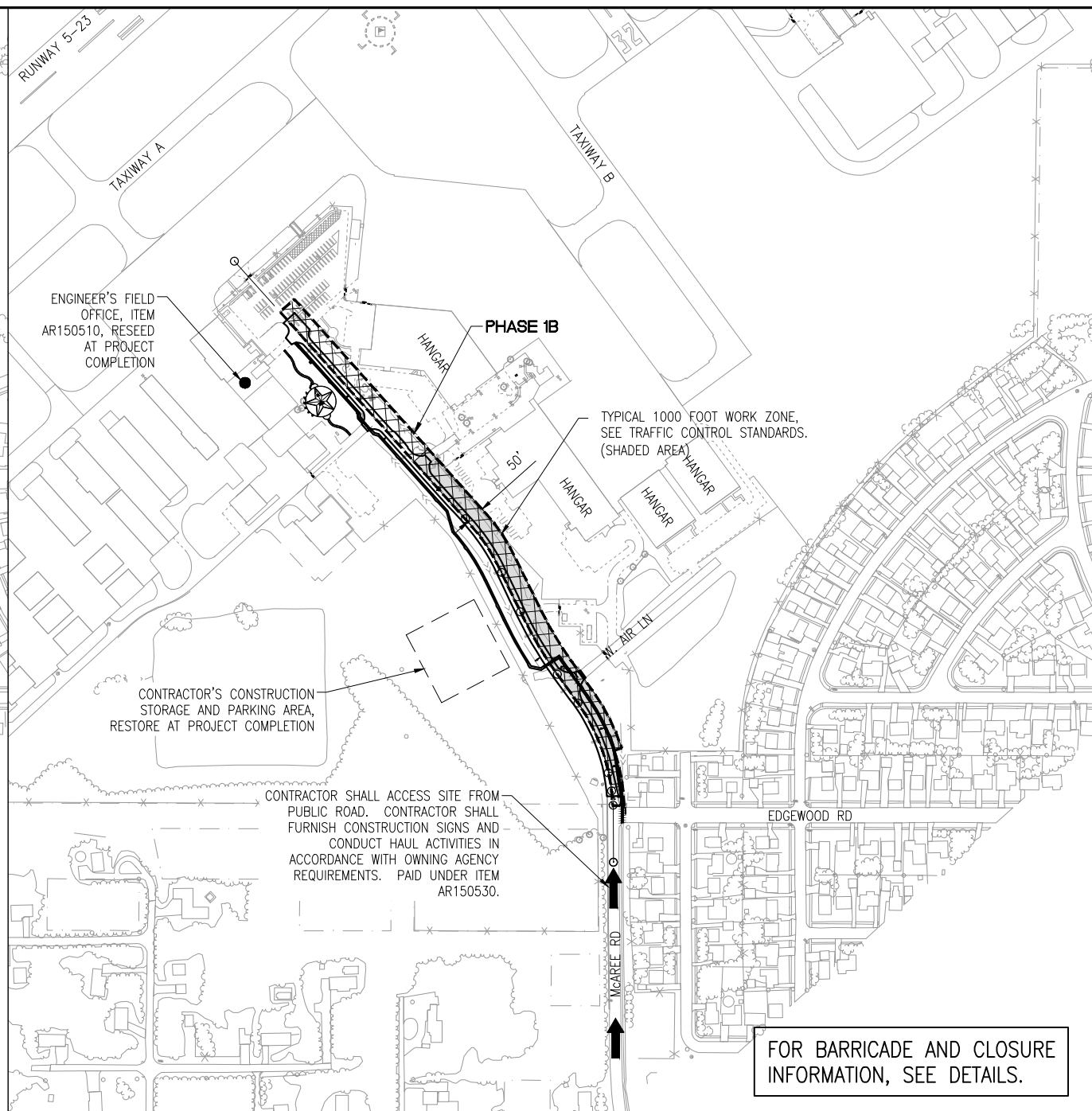
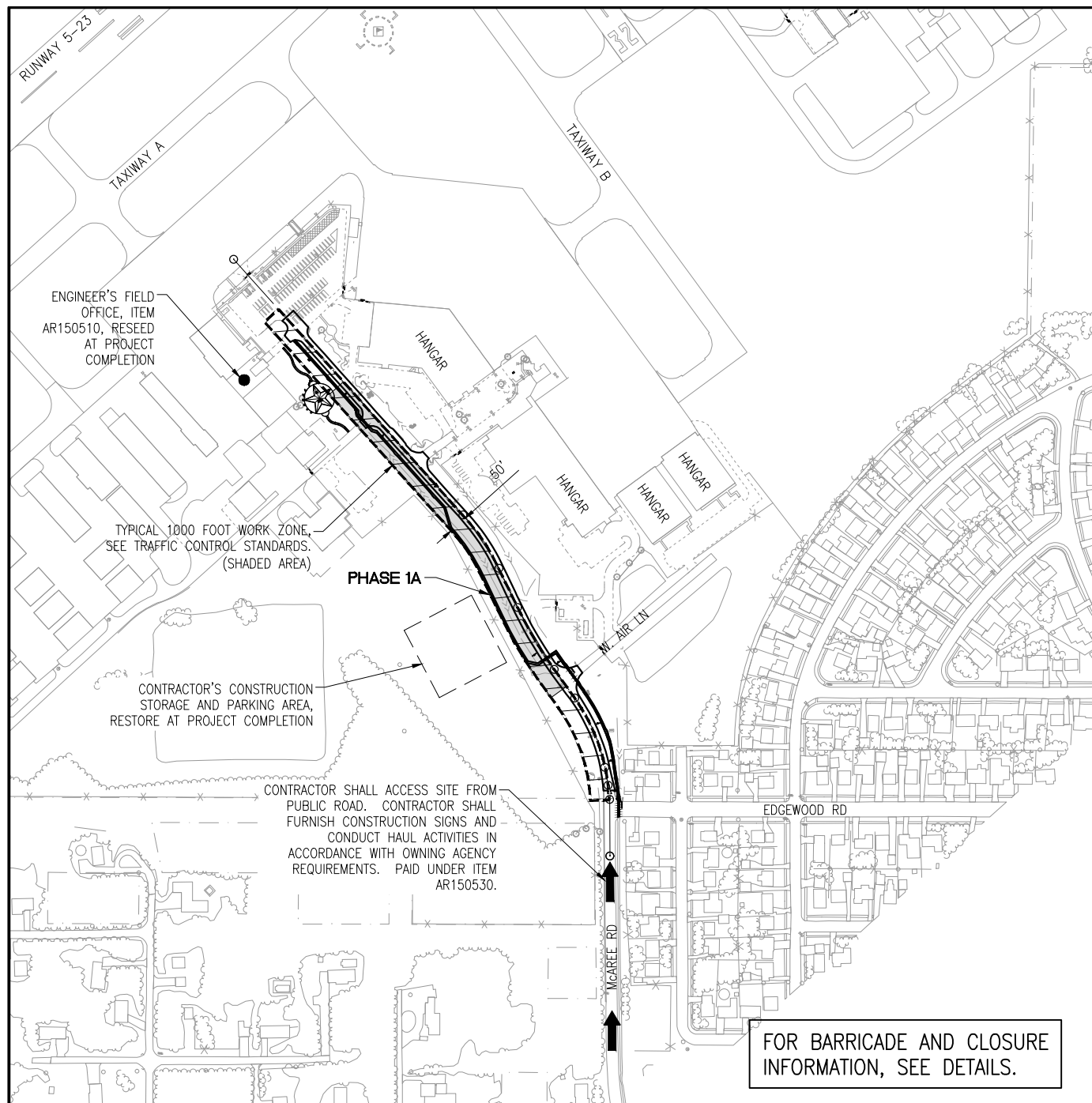

REHABILITATE AIRPORT
ENTRANCE ROAD (BASE BID)
WITH CONSTRUCT SIDEWALK
(ADDITIVE ALTERNATES)

IDA No: UGN-4631

WA073

MARK	DATE	DESCRIPTION		
		DES	DRN	REV

ISSUE:
PROJECT NO: 17A0077
CAD FILE: 05-PHASING1.DWG
DESIGN BY: LDH
DRAWN BY: SCS
REVIEWED BY: KMS 10/17/18

SHEET TITLE

CONSTRUCTION
SAFETY AND
PHASING PLAN -
PHASE 1

PHASE 1A (LEFT OF CENTERLINE)

NOTES:

- ALL CONTRACTOR ACTIVITIES SHALL TAKE PLACE WITHIN CONSTRUCTION LIMIT LINES AS SHOWN. ONE TRAFFIC LANE SHALL REMAIN OPEN AT ALL TIMES. IF BARRICADES ON ANY PORTION OF THE CLOSED LANE SHALL REMAIN OVERNIGHT, THE CLOSED AREAS SHALL BE MARKED AND LIGHTED IN ACCORDANCE WITH IDOT STANDARDS.
- ALL CONSTRUCTION EQUIPMENT WILL BE LIMITED TO A HEIGHT OF 25 FEET UNLESS PRIOR APPROVAL GIVEN BY THE ENGINEER.
- SEE CONSTRUCTION AND SAFETY NOTES, SHEET 4.

THE FOLLOWING ITEMS ARE TO BE COMPLETED IN PHASE 1A:

- INSTALL EROSION CONTROL MEASURES FOR ENTIRE PROJECT AREA.
- MILL EXISTING PAVEMENTS WITHIN PHASE 1A LIMITS.
- CRACK REPAIR OF EXISTING PAVEMENTS WITHIN PHASE 1A LIMITS.
- INSTALL AGGREGATE BASE COURSE FOR PAVED SHOULDER WITHIN PHASE 1A LIMITS.
- INSTALL AGGREGATE SHOULDERS WITHIN PHASE 1A LIMITS.
- INSTALL SIDEWALKS WITHIN PHASE 1A LIMITS. (ADDED ALTERNATE BIDS 1 & 2)

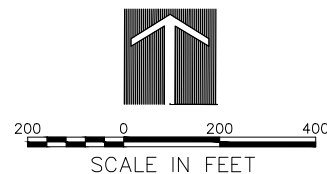

PHASE 1B (RIGHT OF CENTERLINE)

NOTES:

- ALL CONTRACTOR ACTIVITIES SHALL TAKE PLACE WITHIN CONSTRUCTION LIMIT LINES AS SHOWN. ONE TRAFFIC LANE SHALL BE OPEN AT ALL TIMES. IF BARRICADES ON ANY PORTION OF THE CLOSED LANE SHALL REMAIN OVERNIGHT, THE CLOSED AREAS SHALL BE MARKED AND LIGHTED IN ACCORDANCE WITH IDOT STANDARDS.
- ALL CONSTRUCTION EQUIPMENT WILL BE LIMITED TO A HEIGHT OF 25 FEET UNLESS PRIOR APPROVAL GIVEN BY THE ENGINEER.
- SEE CONSTRUCTION AND SAFETY NOTES, SHEET 4.

THE FOLLOWING ITEMS ARE TO BE COMPLETED IN PHASE 1B:

- MILL EXISTING PAVEMENTS WITHIN PHASE 1B LIMITS.
- CRACK REPAIR OF EXISTING PAVEMENTS WITHIN PHASE 1B LIMITS.
- INSTALL AGGREGATE BASE COURSE FOR PAVED SHOULDER WITHIN PHASE 1B LIMITS.
- INSTALL AGGREGATE SHOULDERS WITHIN PHASE 1B LIMITS.
- INSTALL SIDEWALKS WITHIN PHASE 1B LIMITS. (ADDED ALTERNATE BID 1)

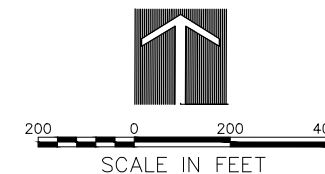

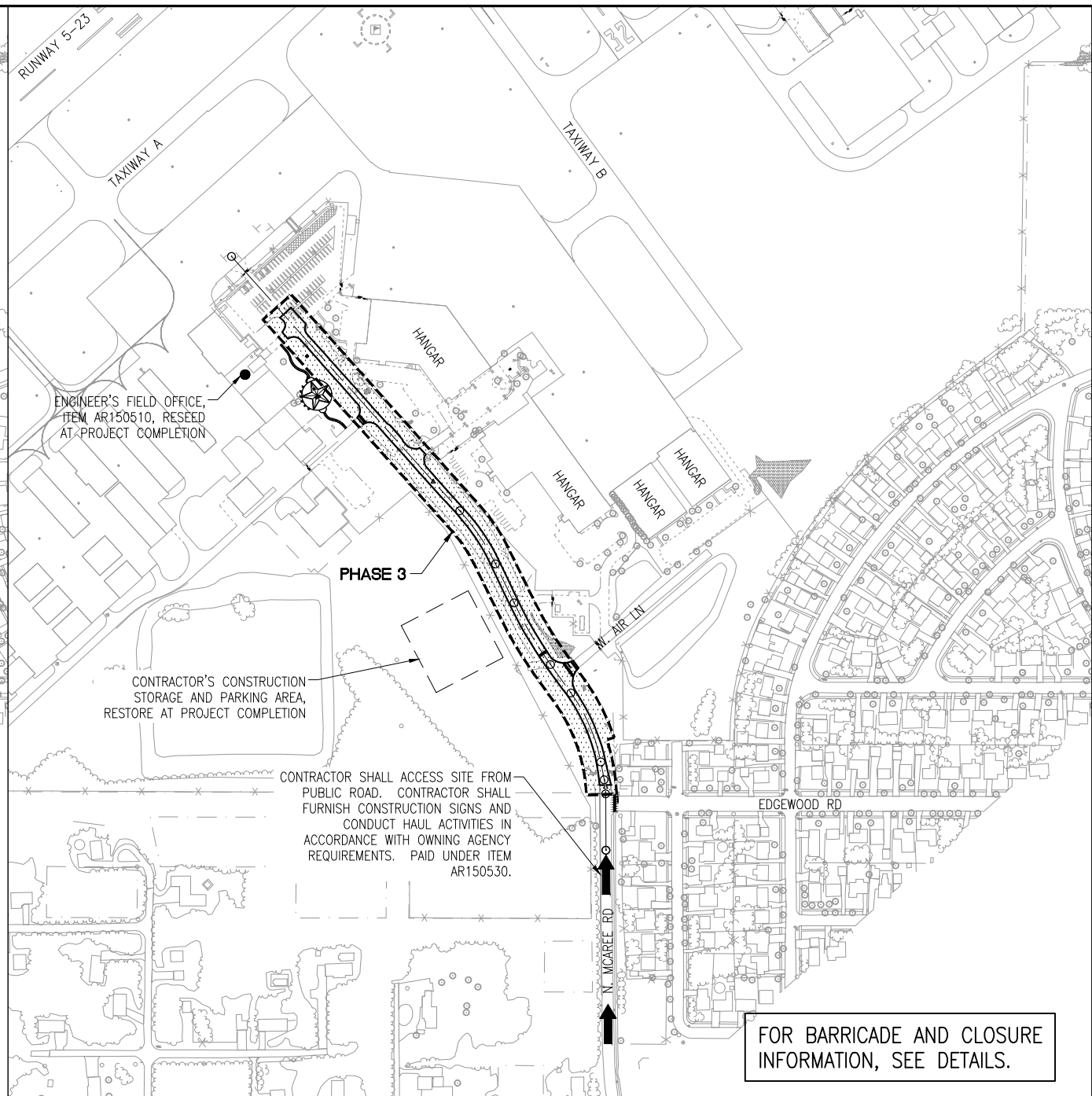
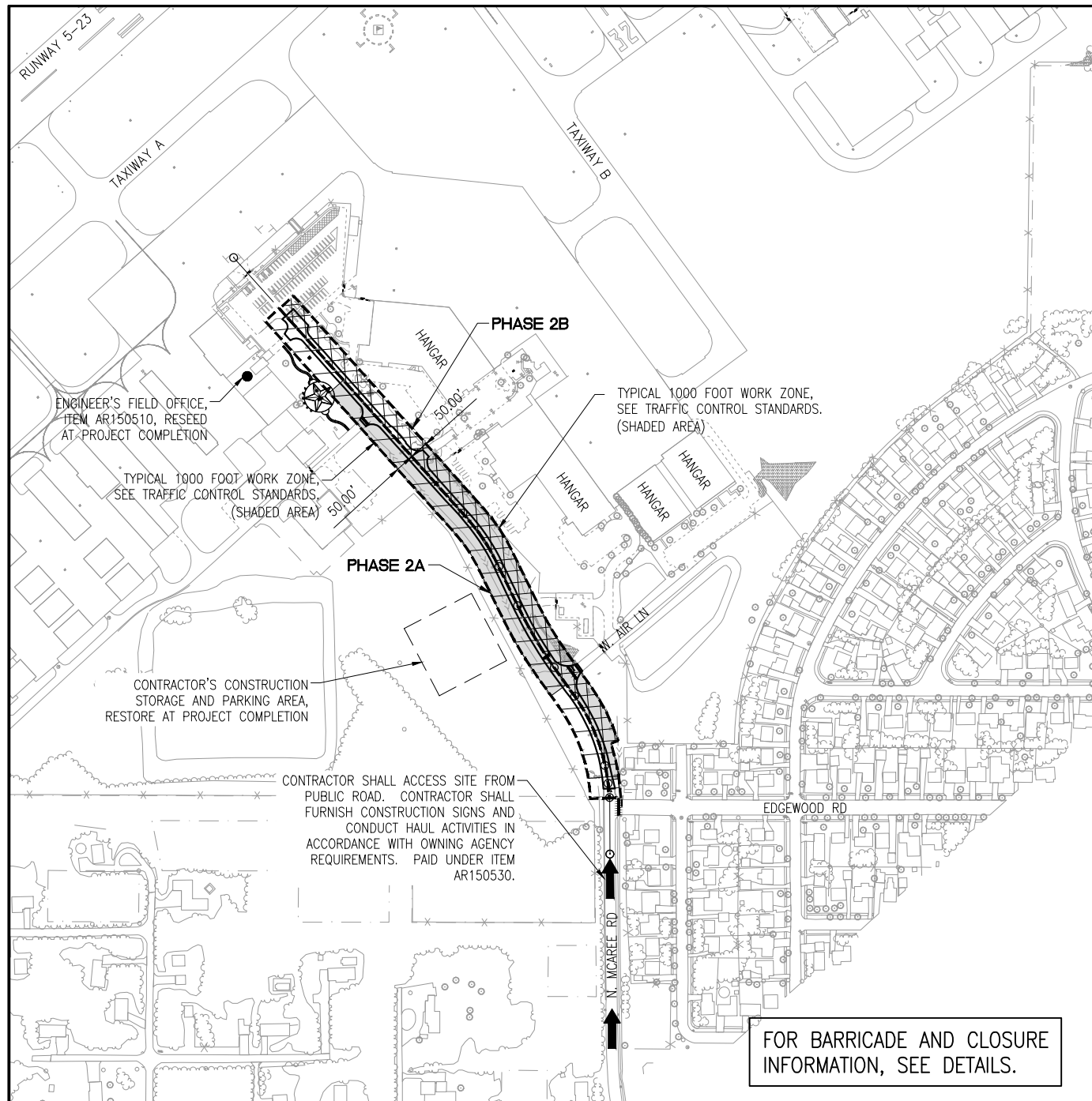

REHABILITATE AIRPORT
ENTRANCE ROAD (BASE BID)
WITH CONSTRUCT SIDEWALK
(ADDITIVE ALTERNATES)

IDA No: UGN-4631

WA073

MARK	DATE	DESCRIPTION		
		DES	DRN	REV

ISSUE:
PROJECT NO: 17A0077
CAD FILE: 06-PHASING2.DWG
DESIGN BY: LDH
DRAWN BY: SCS
REVIEWED BY: KMS 10/17/18

SHEET TITLE

CONSTRUCTION
SAFETY AND
PHASING PLAN -
PHASE 2 & 3

PHASE 2A AND 2B (2A=LEFT; 2B=RIGHT OF CENTERLINE)

- NOTES:
- ALL CONTRACTOR ACTIVITIES SHALL TAKE PLACE WITHIN CONSTRUCTION LIMIT LINES AS SHOWN. ONE TRAFFIC LANE SHALL REMAIN OPEN AT ALL TIMES. IF BARRICADES ON ANY PORTION OF THE CLOSED LANE SHALL REMAIN OVERNIGHT, THE CLOSED AREAS SHALL BE MARKED AND LIGHTED IN ACCORDANCE WITH IDOT STANDARDS.
 - ALL CONSTRUCTION EQUIPMENT WILL BE LIMITED TO A HEIGHT OF 25 FEET UNLESS PRIOR APPROVAL GIVEN BY THE ENGINEER.
 - SEE CONSTRUCTION AND SAFETY NOTES, SHEET 4.
- THE FOLLOWING ITEMS ARE TO BE COMPLETED IN PHASE 2:
- INSTALL SURFACE COURSE WITHIN PHASE 2 LIMITS.
 - TOPSOILING, SEEDING, AND EROSION CONTROL BLANKET WITHIN PHASE 2 LIMITS.

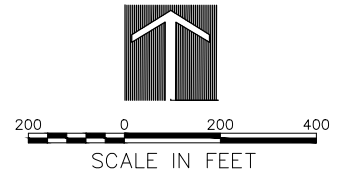

PHASE 3

- NOTES:
- ALL CONTRACTOR ACTIVITIES SHALL TAKE PLACE WITHIN CONSTRUCTION LIMIT LINES AS SHOWN. SEE IDOT STANDARD 701311-03.
 - ALL CONSTRUCTION EQUIPMENT WILL BE LIMITED TO A HEIGHT OF 25 FEET UNLESS PRIOR APPROVAL GIVEN BY THE ENGINEER.
 - SEE CONSTRUCTION AND SAFETY NOTES, SHEET 4.
- THE FOLLOWING ITEMS ARE TO BE COMPLETED IN PHASE 3:
- MARKING OF ENTIRE PROJECT AREA.

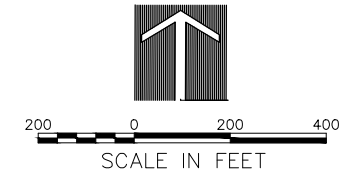

Hanson Professional Services Inc.
 750 Warrenville Road
 Lisle, IL 60532
 phone: 630-990-3800
 fax: 630-990-3801
 Offices Nationwide
 www.hanson-inc.com

Illinois Licensed
 Professional Service Corporation
 #184-001084



WAUKEGAN NATIONAL AIRPORT
 WAUKEGAN PORT DISTRICT
 2601 Plane Rest Drive
 Waukegan, Illinois 60087
 Telephone: 847.244.0055
 Fax: 847.244.3813

REHABILITATE AIRPORT
 ENTRANCE ROAD (BASE BID)
 WITH CONSTRUCT SIDEWALK
 (ADDITIVE ALTERNATES)

IDA No: UGN-4631

WA073

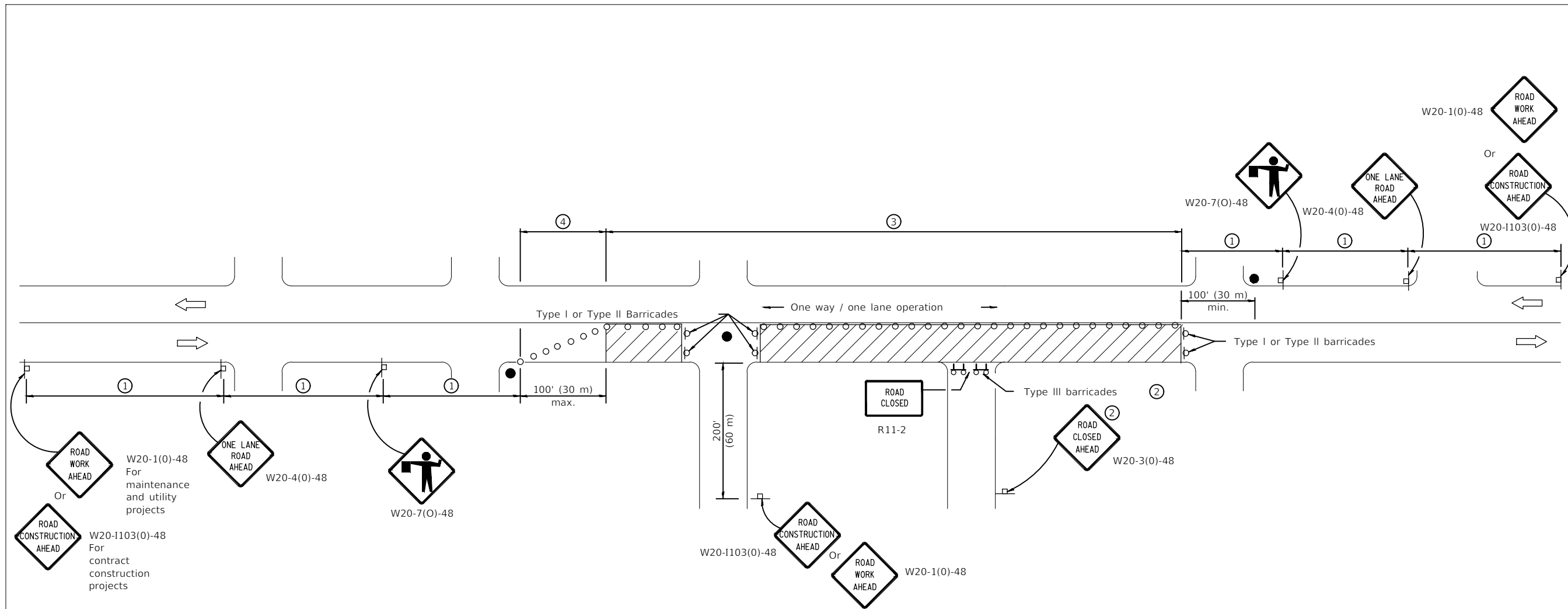

SIGN SPACING	
Posted Speed	Sign Spacing
55	500' (150 m)
50-45	350' (100 m)
<45	200' (60 m)

SYMBOLS

- Work area
- Cone, drum or barricade (not required for moving operations)
- Sign on portable or permanent support
- Flagger with traffic control sign
- Barricade or drum with flashing light
- Type III barricade with flashing lights

- ① Refer to SIGN SPACING TABLE for distances.
- ② For approved sideroad closures.
- ③ Cones at 25' (8 m) centers for 250' (75 m). Additional cones may be placed at 50' (15 m) centers. When drums or Type I or Type II barricades are used, the interval between devices may be doubled.
- ④ Cones, drums or barricades at 20' (6 m) centers.

GENERAL NOTES

This Standard is used where at any time, day or night, any vehicle, equipment, workers or their activities encroach on the pavement requiring the closure of one traffic lane in an urban area.

All dimensions are in inches (millimeters) unless otherwise shown.

**URBAN LANE CLOSURE,
 2L, 2W, UNDIVIDED**

STANDARD 701501-06

MARK	DATE	DESCRIPTION		
		DES	DRN	REV

ISSUE:
 PROJECT NO: 17A0077
 CAD FILE: 07-TRAFFIC.DWG
 DESIGN BY: LDH
 DRAWN BY: SCS
 REVIEWED BY: KMS 10/17/18

SHEET TITLE

TRAFFIC CONTROL
 STANDARDS

Hanson Professional Services Inc.
 750 Warrenville Road
 Lisle, IL 60532
 phone: 630-990-3800
 fax: 630-990-3801
 Offices Nationwide
 www.hanson-inc.com

Illinois Licensed
 Professional Service Corporation
 #184-001084



WAUKEGAN NATIONAL AIRPORT
 WAUKEGAN PORT DISTRICT
 2601 Plane Rest Drive
 Waukegan, Illinois 60087
 Telephone: 847.244.0055
 Fax: 847.244.3813

REHABILITATE AIRPORT
 ENTRANCE ROAD (BASE BID)
 WITH CONSTRUCT SIDEWALK
 (ADDITIVE ALTERNATES)

IDA No: UGN-4631

WA073

MARK	DATE	DESCRIPTION		
		DES	DRN	REV

ISSUE:
 PROJECT NO: 17A0077
 CAD FILE: 08-TRAFFIC.DWG
 DESIGN BY: LDH
 DRAWN BY: SCS
 REVIEWED BY: KMS 10/17/18

SHEET TITLE

TRAFFIC CONTROL
 STANDARDS

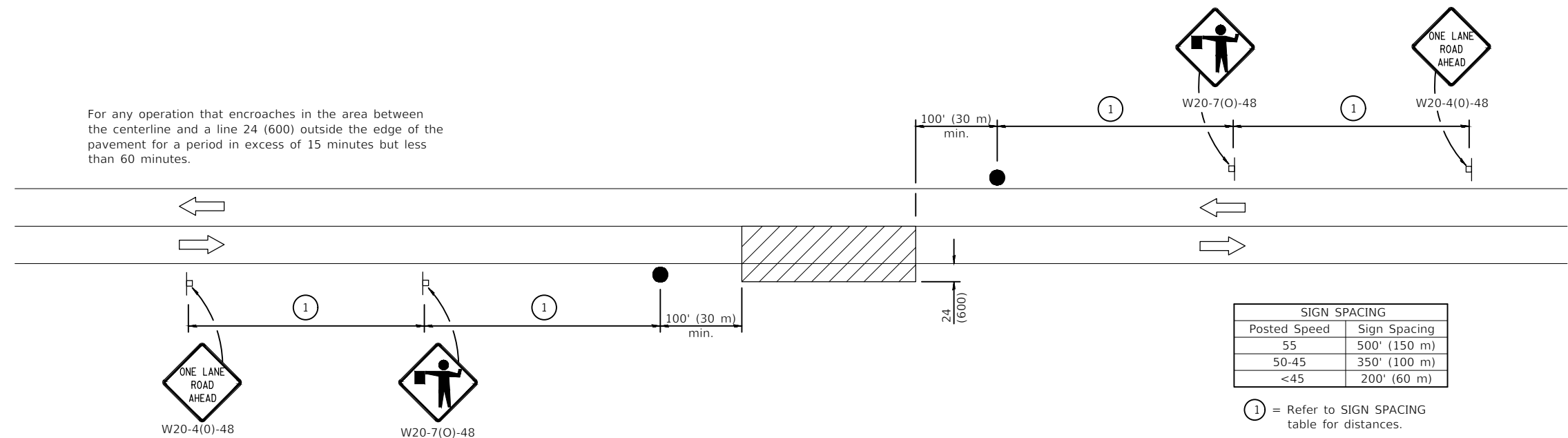
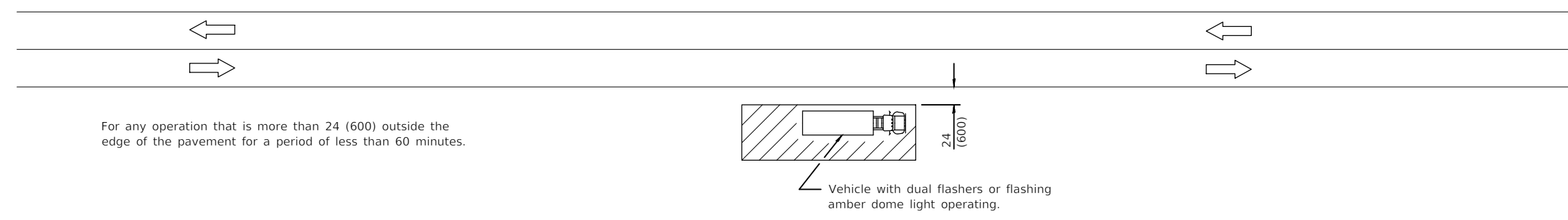
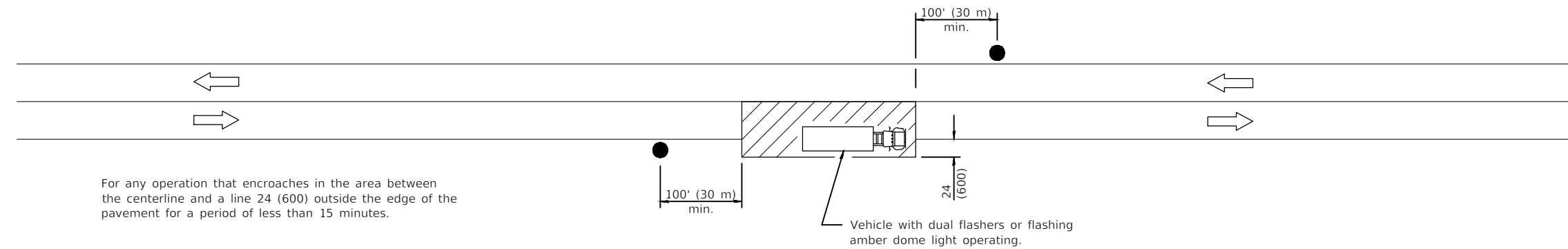

SIGN SPACING	
Posted Speed	Sign Spacing
55	500' (150 m)
50-45	350' (100 m)
<45	200' (60 m)

TYPICAL APPLICATIONS

- Marking patches
- Field survey
- String line
- Utility operations
- Cleaning up debris on pavement

SYMBOLS

- Work area
- Sign on portable or permanent support
- Flagger with traffic control sign

All dimensions are in inches (millimeters) unless otherwise shown.

**LANE CLOSURE, 2L, 2W,
 SHORT TIME OPERATIONS**

STANDARD 701301-04

Hanson Professional Services Inc.
 750 Warrenville Road
 Lisle, IL 60532
 phone: 630-990-3800
 fax: 630-990-3801
 Offices Nationwide
 www.hanson-inc.com

Illinois Licensed
 Professional Service Corporation
 #184-001084



WAUKEGAN NATIONAL AIRPORT
 WAUKEGAN PORT DISTRICT
 2601 Plane Rest Drive
 Waukegan, Illinois 60087
 Telephone: 847.244.0055
 Fax: 847.244.3813

REHABILITATE AIRPORT
 ENTRANCE ROAD (BASE BID)
 WITH CONSTRUCT SIDEWALK
 (ADDITIVE ALTERNATES)

IDA No: UGN-4631

WA073

MARK	DATE	DESCRIPTION		
		DES	DRN	REV

ISSUE:
 PROJECT NO: 17A0077
 CAD FILE: 09-TRAFFIC.DWG
 DESIGN BY: LDH
 DRAWN BY: SCS
 REVIEWED BY: KMS 10/17/18

SHEET TITLE

TRAFFIC CONTROL
 STANDARDS

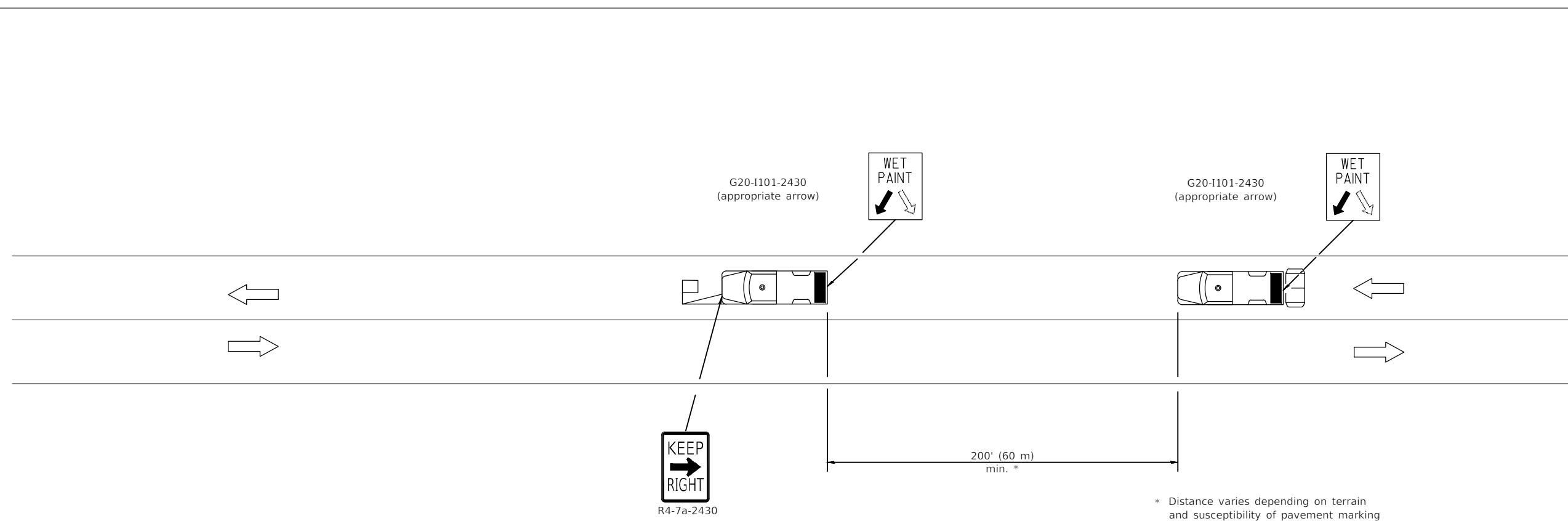

* Distance varies depending on terrain and susceptibility of pavement marking or crack sealant to wheel tracking.

TYPICAL APPLICATIONS

- Landscaping work
- Utility work
- Pavement marking
- Weed spraying
- Roadometer measurements
- Debris cleanup
- Crack pouring

SYMBOLS

- Arrow board (Hazard Mode only)
- Truck with headlights, emergency flashers and flashing amber light. (visible from all directions)
- 18x18 (450x450) min. orange flag (use when guide wheel is used)
- Truck mounted attenuator

GENERAL NOTES

This Standard is used where any vehicle, equipment, workers or their activities will require a continuous moving operation where the average speed is greater than 3 mph (5 km/h).

For shoulder operations not encroaching on the pavement, use DETAIL A, Standard 701426.

All dimensions are in inches (millimeters) unless otherwise shown.

**LANE CLOSURE 2L, 2W
 MOVING OPERATIONS-
 DAY ONLY**

STANDARD 701311-03

Hanson Professional Services Inc.
 750 Warrenville Road
 Lisle, IL 60532
 phone: 630-990-3800
 fax: 630-990-3801
 Offices Nationwide
 www.hanson-inc.com

Illinois Licensed
 Professional Service Corporation
 #184-001084



WAUKEGAN NATIONAL AIRPORT
 WAUKEGAN PORT DISTRICT
 2601 Plane Rest Drive
 Waukegan, Illinois 60087
 Telephone: 847.244.0055
 Fax: 847.244.3813

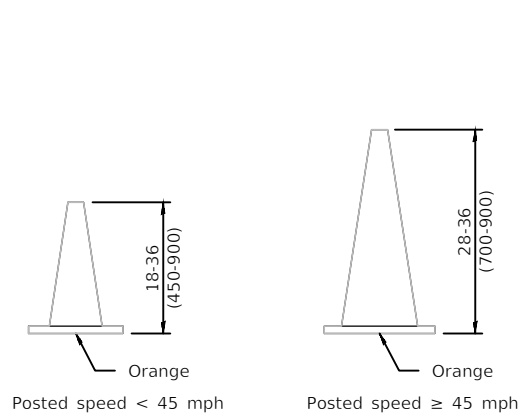

CONE FOR DAYTIME

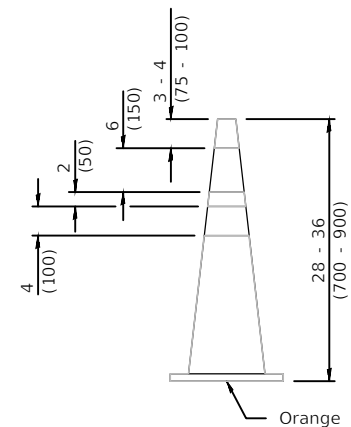

REFLECTORIZED CONE FOR NIGHTTIME

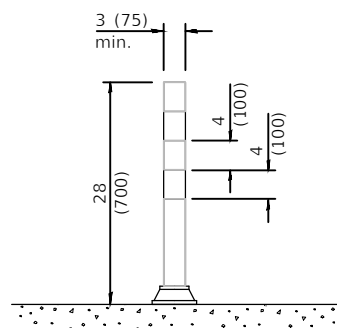

TUBULAR MARKER

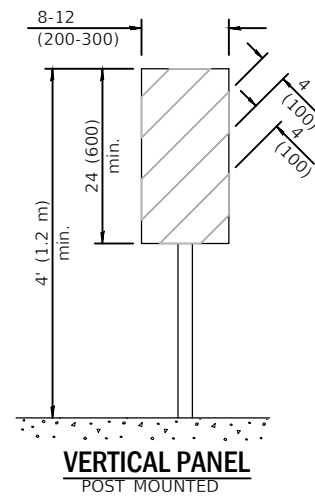

VERTICAL PANEL POST MOUNTED

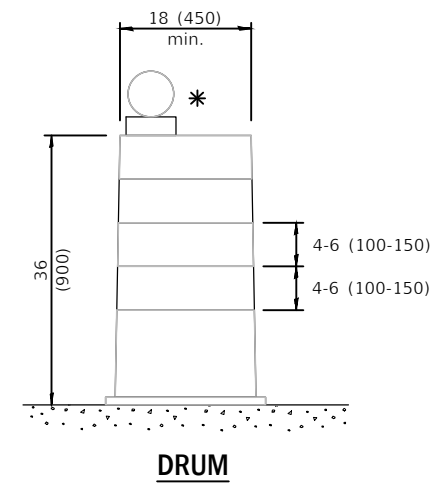

DRUM

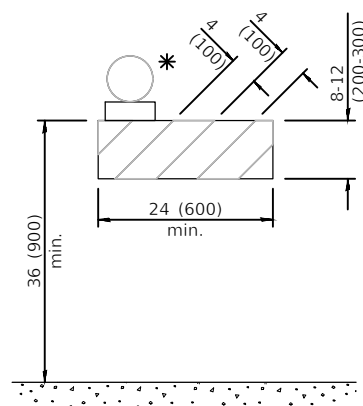

TYPE I BARRICADE

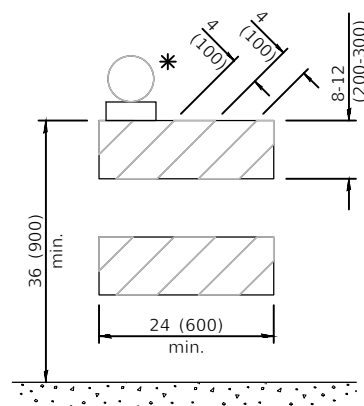

TYPE II BARRICADE

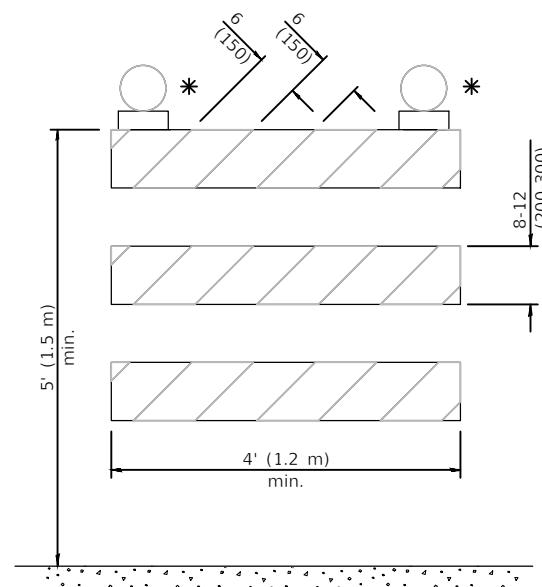

TYPE III BARRICADE

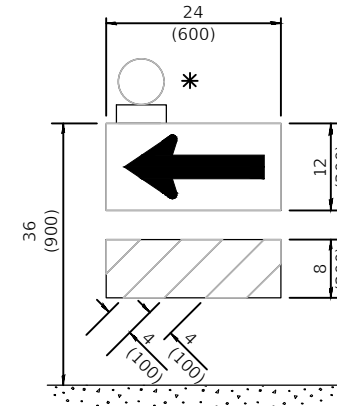

DIRECTION INDICATOR BARRICADE

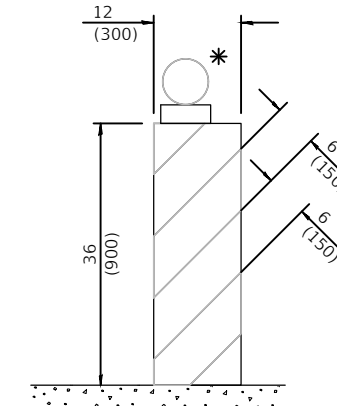

VERTICAL BARRICADE

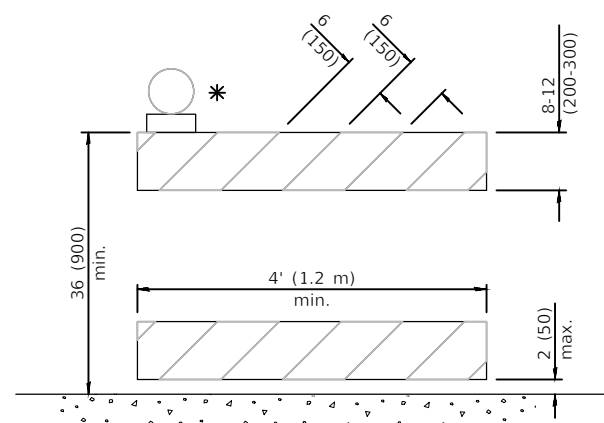

DETECTABLE PEDESTRIAN CHANNELIZING BARRICADE

* Warning lights (if required)

GENERAL NOTES

All heights shown shall be measured above the pavement surface.

All dimensions are in inches (millimeters) unless otherwise shown.

TRAFFIC CONTROL DEVICES

(Sheet 1 of 3)

STANDARD 701901-07

REHABILITATE AIRPORT ENTRANCE ROAD (BASE BID) WITH CONSTRUCT SIDEWALK (ADDITIVE ALTERNATES)

IDA No: UGN-4631

WA073

MARK	DATE	DESCRIPTION		
		DES	DRN	REV

ISSUE:
 PROJECT NO: 17A0077
 CAD FILE: 10-TRAFFIC.DWG
 DESIGN BY: LDH
 DRAWN BY: SCS
 REVIEWED BY: KMS 10/17/18

SHEET TITLE

TRAFFIC CONTROL STANDARDS

Hanson Professional Services Inc.
750 Warrenville Road
Lisle, IL 60532
phone: 630-990-3800
fax: 630-990-3801
Offices Nationwide
www.hanson-inc.com

Illinois Licensed
Professional Service Corporation
#184-001084



WAUKEGAN NATIONAL AIRPORT
WAUKEGAN PORT DISTRICT
2601 Plane Rest Drive
Waukegan, Illinois 60087
Telephone: 847.244.0055
Fax: 847.244.3813

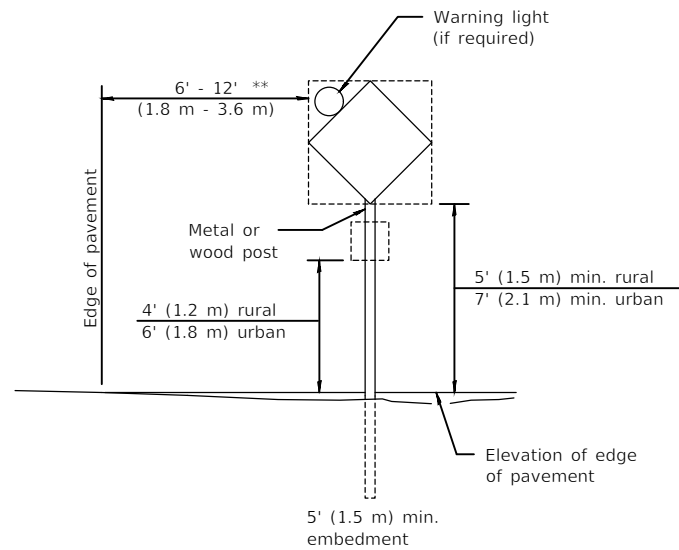

POST MOUNTED SIGNS

** When curb or paved shoulder are present this dimension shall be 24 (600) to the face of curb or 6' (1.8 m) to the outside edge of the paved shoulder.

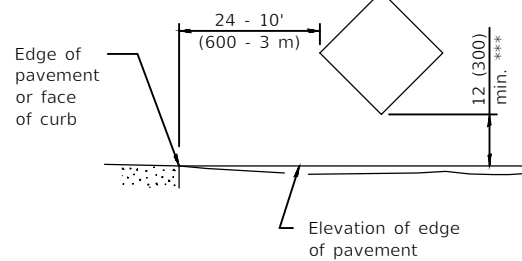

SIGNS ON TEMPORARY SUPPORTS

*** When work operations exceed four days, this dimension shall be 5' (1.5 m) min. If located behind other devices, the height shall be sufficient to be seen completely above the devices.

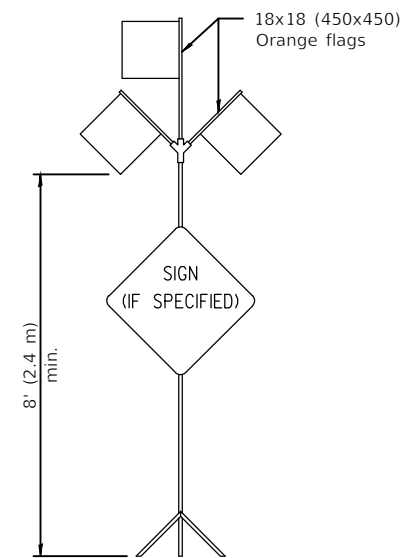

HIGH LEVEL WARNING DEVICE

ROAD CONSTRUCTION NEXT X MILES	END CONSTRUCTION
G20-1104(0)-6036	G20-1105(0)-6024

This signing is required for all projects 2 miles (3200 m) or more in length.

ROAD CONSTRUCTION NEXT X MILES sign shall be placed 500' (150 m) in advance of project limits.

END CONSTRUCTION sign shall be erected at the end of the job unless another job is within 2 miles (3200 m).

Dual sign displays shall be utilized on multi-lane highways.

WORK LIMIT SIGNING

WORK ZONE	W21-III5(0)-3618
SPEED LIMIT XX	R2-1-3648
PHOTO ENFORCED	R10-1108p-3618 ****
\$XXX FINE MINIMUM	R2-1106p-3618

Sign assembly as shown on Standards or as allowed by District Operations.

END WORK ZONE SPEED LIMIT	G20-1103-6036
---------------------------	---------------

This sign shall be used when the above sign assembly is used.

HIGHWAY CONSTRUCTION SPEED ZONE SIGNS

**** R10-1108p shall only be used along roadways under the jurisdiction of the State.

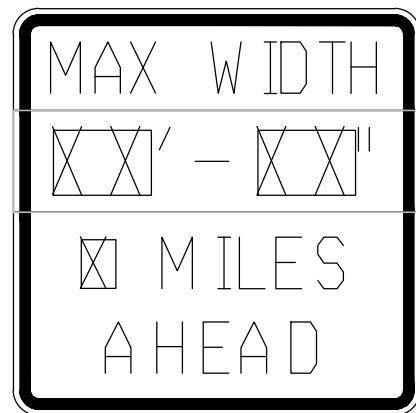

W12-1103-4848

WIDTH RESTRICTION SIGN

XX'-XX" width and X miles are variable.

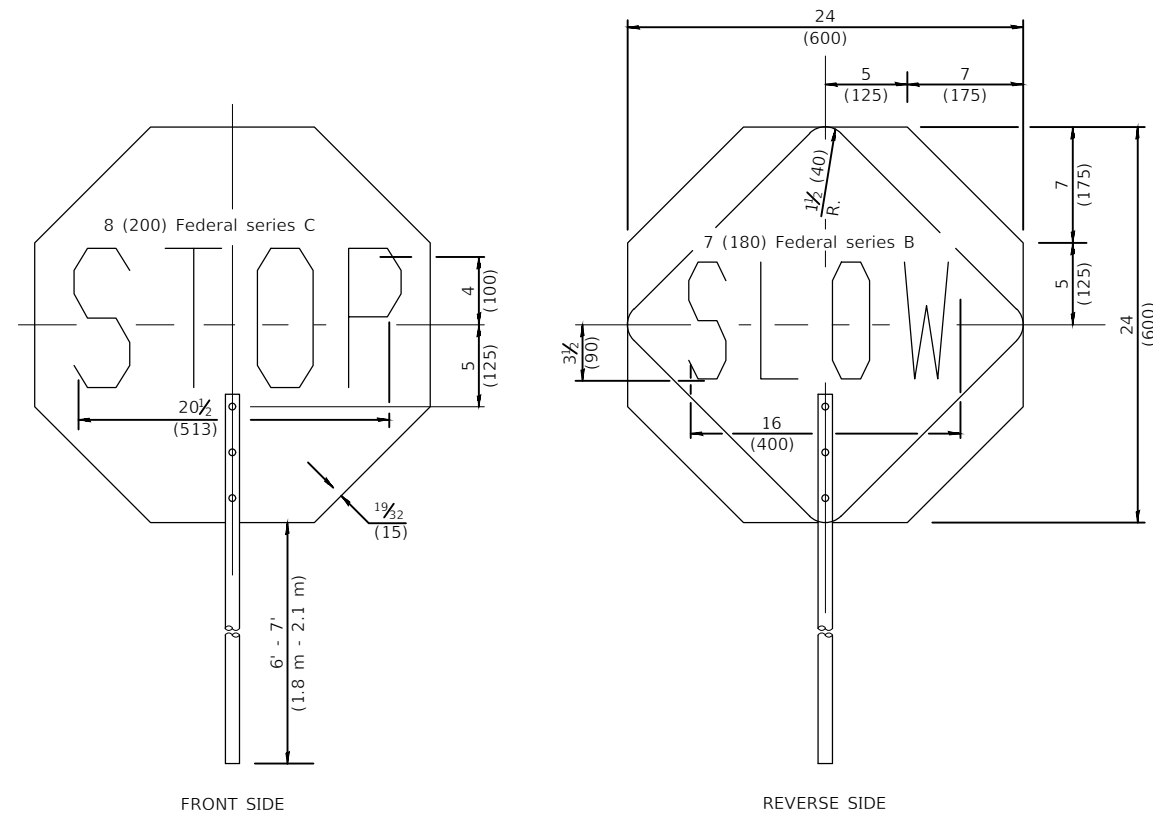

FLAGGER TRAFFIC CONTROL SIGN

TRAFFIC CONTROL DEVICES

(Sheet 2 of 3)

STANDARD 701901-07

REHABILITATE AIRPORT ENTRANCE ROAD (BASE BID) WITH CONSTRUCT SIDEWALK (ADDITIVE ALTERNATES)

IDA No: UGN-4631

WA073

MARK	DATE	DESCRIPTION		
		DES	DRN	REV

ISSUE:
PROJECT NO: 17A0077
CAD FILE: 11-TRAFFIC.DWG
DESIGN BY: LDH
DRAWN BY: SCS
REVIEWED BY: KMS 10/17/18

SHEET TITLE

TRAFFIC CONTROL STANDARDS



WAUKEGAN NATIONAL AIRPORT
WAUKEGAN PORT DISTRICT
2601 Plane Rest Drive
Waukegan, Illinois 60087
Telephone: 847.244.0055
Fax: 847.244.3813

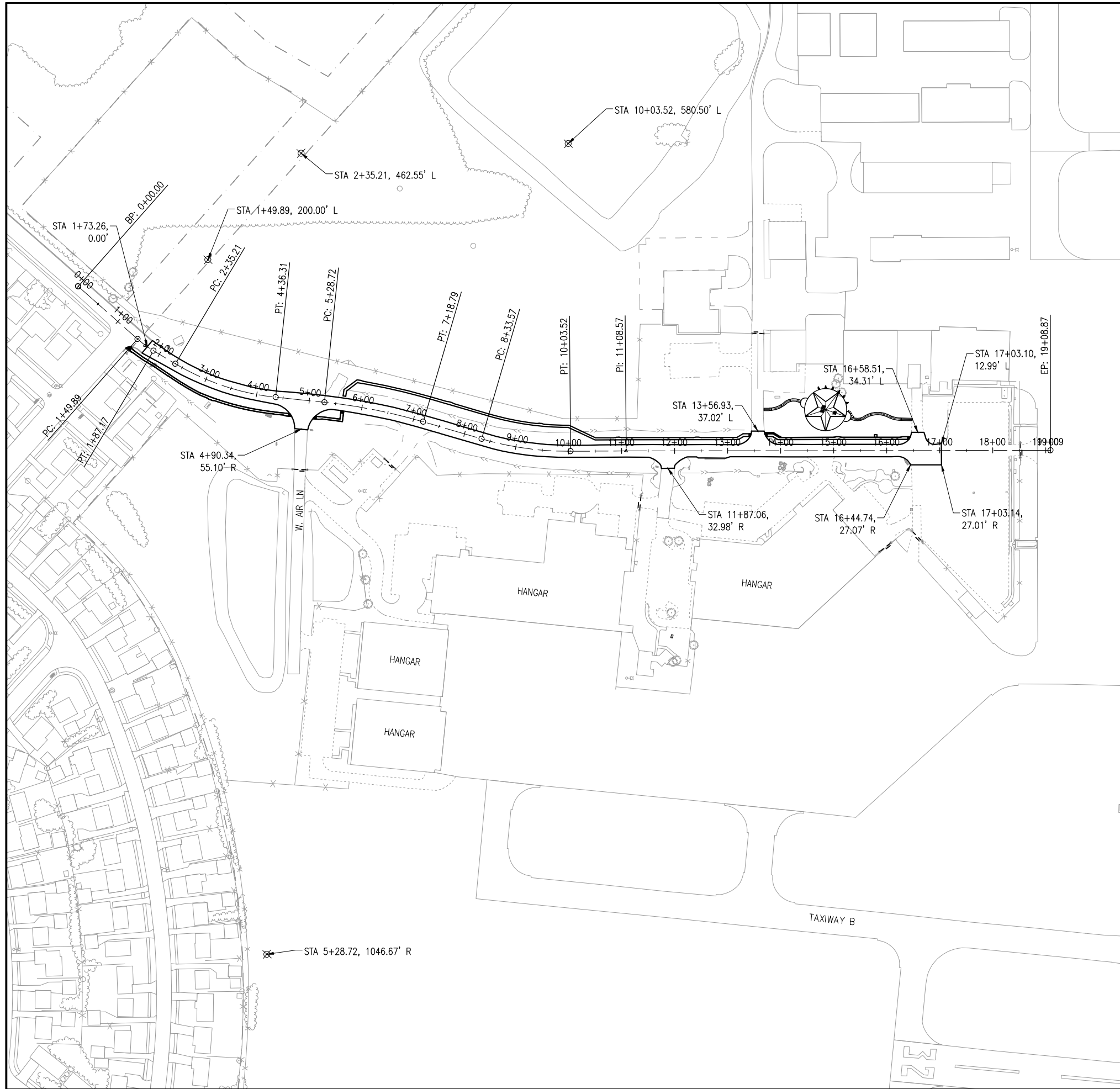
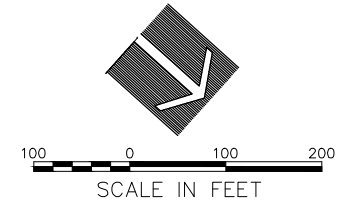

McAREE ROAD ALIGNMENT DATA			
DESCRIPTION	STATION	PROJECT COORDINATES	
		NORTHING	EASTING
BEGINNING	0+00.00	2093627.426	1110683.619
PC OF CURVE	1+49.89	2093777.314	1110682.971
CENTER OF CURVE (200.00' R)	1+49.89	2093776.450	1110482.973
PT OF CURVE	1+87.17	2093814.361	1110679.347
PC OF CURVE	2+35.21	2093861.530	1110670.241
CENTER OF CURVE (462.55' R)	2+35.21	2093773.851	1110216.077
PT OF CURVE	4+36.31	2094044.671	1110591.056
PC OF CURVE	5+28.72	2094119.585	1110536.951
CENTER OF CURVE (1,046.67' R)	5+28.72	2094732.402	1111385.463
PT OF CURVE	7+18.79	2094282.903	1110440.228
PC OF CURVE	8+33.57	2094386.551	1110390.939
CENTER OF CURVE (580.50' R)	10+03.52	2094137.251	1109866.697
PT OF CURVE	10+03.52	2094527.239	1110296.685
PI	11+08.57	2094605.054	1110226.109
END	19+08.87	2095200.958	1109691.903

REHABILITATE AIRPORT
ENTRANCE ROAD (BASE BID)
WITH CONSTRUCT SIDEWALK
(ADDITIVE ALTERNATES)

IDA No: UGN-4631

WA073

MARK	DATE	DESCRIPTION		
		DES	DRN	REV

ISSUE:
PROJECT NO: 17A0077
CAD FILE: 12-ALIGNMENT.DWG
DESIGN BY: LDH
DRAWN BY: SCS
REVIEWED BY: KMS 10/17/18

SHEET TITLE

ALIGNMENT DATA
TABLE & PAVEMENT
LAYOUT



REHABILITATE AIRPORT
ENTRANCE ROAD (BASE BID)
WITH CONSTRUCT SIDEWALK
(ADDITIVE ALTERNATES)

IDA No: UGN-4631

WA073

MARK	DATE	DESCRIPTION		
		DES	DRN	REV

ISSUE:

PROJECT NO: 17A0077

CAD FILE: 13-TYPICAL SEC (2).DWG

DESIGN BY: LDH

DRAWN BY: SCS

REVIEWED BY: KMS 10/17/18

SHEET TITLE

TYPICAL SECTION
AND PAVEMENT
DETAILS

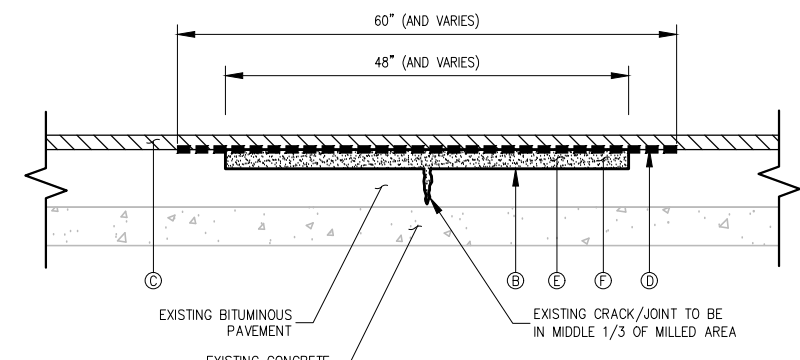

NOTES:

- TACK COAT SHALL BE APPLIED TO MILLED SURFACE OUTSIDE OF CRACK CONTROL MATERIAL.
- CRACK CONTROL MATERIAL SHALL OVERLAP BITUMINOUS SAND MIX 6" EACH SIDE.
- BITUMINOUS PAVEMENT SAWING TO BE PAID FOR AS ITEM AR401665.

- Ⓑ PROPOSED BITUMINOUS TACK COAT, ITEM AR603510.
- Ⓒ PROPOSED OVERLAY
- Ⓓ CRACK CONTROL MATERIAL (60" WIDE), ITEM AR201670.
- Ⓔ BITUMINOUS SAND MIX - 2 INCH, ITEM AR800972.
- Ⓕ PAVEMENT MILLING, ITEM AR401650.

**TYPICAL SECTION - PARTIAL DEPTH
BITUMINOUS REPAIR
TYPE C**

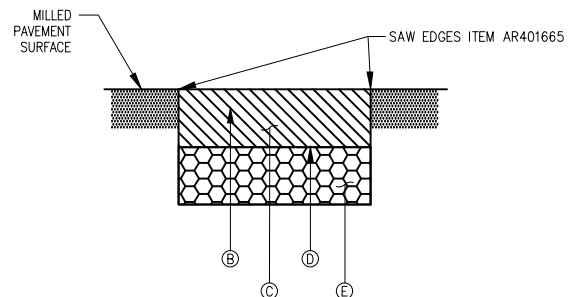

NOTE:

ALL WORK TO BE PAID UNDER AR401910, EXCEPT SAWING PAID UNDER AR401665.

REMOVE AND REPLACE BITUMINOUS PAVEMENT

- Ⓑ PROPOSED BITUMINOUS TACK COAT (BETWEEN ALL LIFTS, .15 GALLONS/SQUARE YARD)
- Ⓒ PROPOSED 4 INCH BITUMINOUS BASE/SURFACE COURSE (MAX. 3 INCH LIFT)
- Ⓓ PROPOSED BITUMINOUS PRIME COAT (.30 GALLONS/SQUARE YARD)
- Ⓔ PROPOSED 6 INCH CRUSHED AGGREGATE BASE COURSE

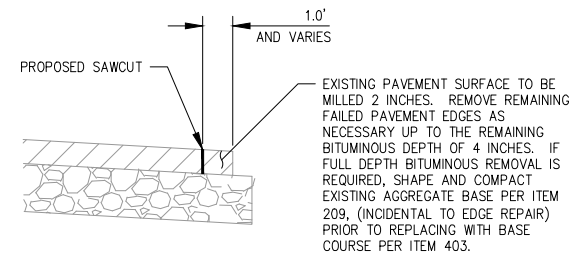

NOTES:

- TACK COAT SHALL BE APPLIED IF ONLY PARTIAL BITUMINOUS DEPTH IS REMOVED.
- PRIME COAT SHALL BE APPLIED IF FULL BITUMINOUS DEPTH REMOVED. TACK COAT SHALL BE PLACED BETWEEN LIFTS.
- BITUMINOUS PAVEMENT SAWING TO BE PAID FOR AS ITEM AR401665.
- SHAPING/COMPACTING EXISTING AGGREGATE, TACK/PRIME COAT AND BITUMINOUS MATERIAL ARE INCIDENTAL TO EDGE REPAIR.

TYPICAL SECTION - EGDE REPAIR

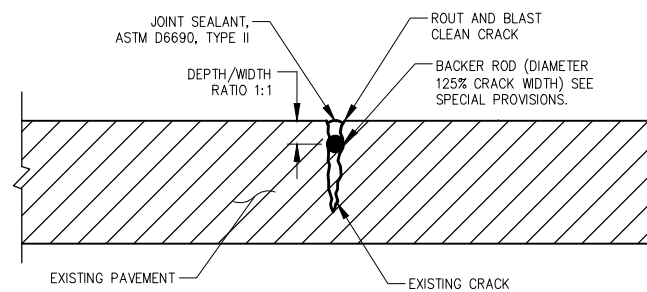

**CLEAN AND SEAL CRACKS
TYPE A**

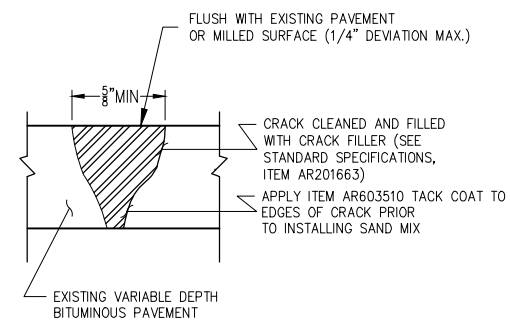

NOTES:

- CRACKS TO BE FILLED WITH SAND MIX SHALL BE AS SHOWN IN PLANS OR AS DESIGNATED BY THE RESIDENT ENGINEER.
- SAND MIX CRACK REPAIR SHALL BE USED ON ALL TYPE B CRACKS, OR AS DESIGNATED BY THE RESIDENT ENGINEER.
- CONTRACTOR SHALL ROUTE, CRACK PLOW AND REMOVE LOOSE FILLER, LOOSE AGGREGATE AND LAITANCE WITH COMPRESSED AIR AS SPECIFIED PRIOR TO TACK COAT AND SEALING.

**SAND MIX CRACK REPAIR DETAIL
TYPE B**

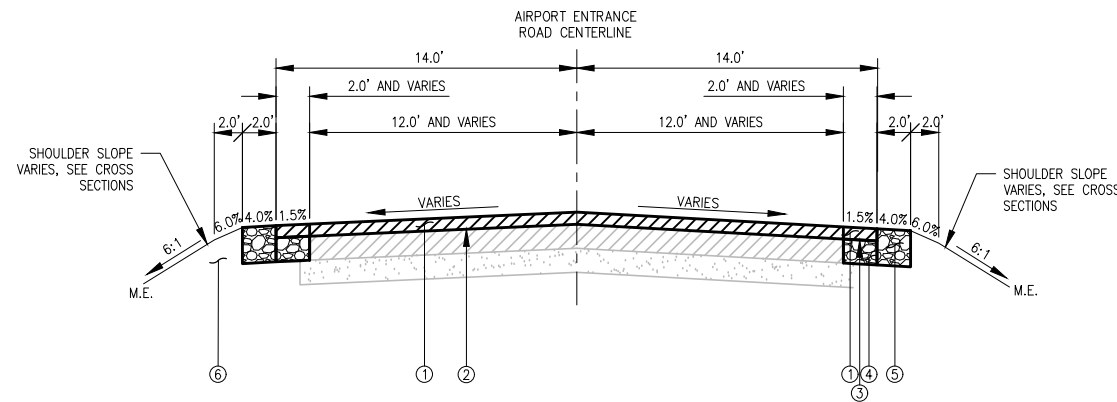

TYPICAL SECTION - ENTRANCE ROAD

(SECTION SHOWN LOOKING NORTHWEST)

- Ⓛ PROPOSED 2.0 INCH BITUMINOUS SURFACE COURSE, ITEM AR401613
- Ⓜ PROPOSED BITUMINOUS TACK COAT, ITEM AR603510
- Ⓨ PROPOSED BITUMINOUS PRIME COAT, ITEM AR602510
- Ⓩ PROPOSED 7 INCH AGGREGATE BASE COURSE, AR209607
- ⓐ PROPOSED 9 INCH AGGREGATE BASE COURSE, ITEM AR209609
- ⓑ PROPOSED TOPSOILING, ITEM AR905510

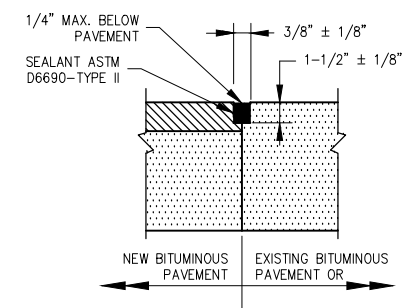

NOTE:

ALL BITUMINOUS/BITUMINOUS JOINT SEALING TO BE PAID UNDER SAW AND SEAL BITUMINOUS JOINTS, ITEM AR401660.

BITUMINOUS/BITUMINOUS SEAL



**REHABILITATE AIRPORT
ENTRANCE ROAD (BASE BID)
WITH CONSTRUCT SIDEWALK
(ADDITIVE ALTERNATES)**

IDA No: UGN-4631

WA073

MARK	DATE	DESCRIPTION		
		DES	DRN	REV

ISSUE:
PROJECT NO: 17A0077
CAD FILE: 16-SWPPP DET.DWG
DESIGN BY: LDH
DRAWN BY: SCS
REVIEWED BY: KMS 10/17/18

SHEET TITLE

SWPPP DETAILS

SEDIMENTATION AND EROSION CONTROL NOTES:

- SEDIMENT CONTROL MEASURES SHALL BE INSTALLED PRIOR TO THE COMMENCEMENT OF HYDROLOGIC DISTURBANCE OF UPLAND AREAS.
- FOR THOSE DEVELOPMENTS THAT REQUIRE A DESIGNATED EROSION CONTROL INSPECTOR (DECI), INSPECTIONS AND DOCUMENTATION SHALL BE PERFORMED, AT A MINIMUM:
 - UPON COMPLETION OF SEDIMENT AND RUNOFF CONTROL MEASURES (INCLUDING PERIMETER CONTROLS AND DIVERSIONS), PRIOR TO PROCEEDING WITH ANY OTHER EARTH DISTURBANCE OR GRADING.
 - AFTER EVERY SEVEN (7) CALENDAR DAYS OR STORM EVENT WITH GREATER THAN 0.5 INCH OF RAINFALL OR LIQUID EQUIVALENT PRECIPITATION.
- SOIL DISTURBANCE SHALL BE CONDUCTED IN SUCH A MANNER AS TO MINIMIZE EROSION. IF STRIPPING, CLEARING, GRADING, OR LANDSCAPING ARE TO BE DONE IN PHASES, THE PERMITTEE SHALL PLAN FOR APPROPRIATE SOIL EROSION AND SEDIMENT CONTROL MEASURES.
- A STABILIZED MAT OF CRUSHED STONE MEETING IDOT GRADATION CA-01 UNDERLAIN WITH FILTER FABRIC AND IN ACCORDANCE WITH THE ILLINOIS URBAN MANUAL, OR OTHER APPROPRIATE MEASURE(S) AS APPROVED BY THE ENFORCEMENT OFFICER, SHALL BE INSTALLED AT ANY POINT WHERE TRAFFIC WILL BE ENTERING OR LEAVING A CONSTRUCTION SITE. SEDIMENT OR SOIL REACHING AN IMPROVED PUBLIC RIGHT-OF-WAY, STREET, ALLEY OR PARKING AREA SHALL BE REMOVED BY SCRAPING OR STREET CLEANING AS ACCUMULATIONS WARRANT AND TRANSPORTED TO A CONTROLLED SEDIMENT DISPOSAL AREA.
- TEMPORARY DIVERSIONS SHALL BE CONSTRUCTED AS NECESSARY TO DIRECT ALL RUNOFF FROM HYDROLOGICALLY DISTURBED AREAS TO AN APPROPRIATE SEDIMENT TRAP OR BASIN.
- DISTURBED AREAS SHALL BE STABILIZED WITH TEMPORARY OR PERMANENT MEASURES WITHIN SEVEN (7) CALENDAR DAYS FOLLOWING THE END OF ACTIVE HYDROLOGIC DISTURBANCE OR REDISTURBANCE.
- ALL STOCKPILES SHALL HAVE APPROPRIATE MEASURES TO PREVENT EROSION. STOCKPILES SHALL NOT BE PLACED IN FLOOD PRONE AREAS OR WETLANDS AND DESIGNATED BUFFERS.
- SLOPES STEEPER THAN 3H:1V SHALL BE STABILIZED WITH APPROPRIATE MEASURES AS APPROVED BY THE ENFORCEMENT OFFICER.
- APPROPRIATE EROSION CONTROL BLANKET SHALL BE INSTALLED ON ALL INTERIOR DETENTION BASIN SIDE SLOPES BETWEEN THE NORMAL WATER LEVEL AND HIGH WATER LEVEL.
- STORM SEWERS THAT ARE OR WILL BE FUNCTIONING DURING CONSTRUCTION SHALL BE PROTECTED BY AN APPROPRIATE SEDIMENT CONTROL MEASURE.
- IF DEWATERING SERVICES ARE USED, ADJOINING PROPERTIES AND DISCHARGE LOCATIONS SHALL BE PROTECTED FROM EROSION AND SEDIMENTATION. DISCHARGES SHALL BE ROUTED THROUGH AN APPROVED ANIONIC POLYMER DEWATERING SYSTEM OR A SIMILAR MEASURE AS APPROVED BY THE ENFORCEMENT OFFICER. DEWATERING SYSTEMS SHOULD BE INSPECTED DAILY DURING OPERATIONAL PERIODS. THE ENFORCEMENT OFFICER, OR APPROVED REPRESENTATIVE, MUST BE PRESENT AT THE COMMENCEMENT OF DEWATERING ACTIVITIES.
- IF INSTALLED SOIL EROSION AND SEDIMENT CONTROL MEASURES DO NOT MINIMIZE SEDIMENT LEAVING THE DEVELOPMENT SITE, ADDITIONAL MEASURES SUCH AS ANIONIC POLYMERS OR FILTRATION SYSTEMS MAY BE REQUIRED BY THE ENFORCEMENT OFFICER.
- ALL TEMPORARY AND PERMANENT EROSION CONTROL MEASURES MUST BE MAINTAINED AND REPAIRED AS NEEDED. THE PROPERTY OWNER SHALL BE ULTIMATELY RESPONSIBLE FOR MAINTENANCE AND REPAIR.
- ALL TEMPORARY SEDIMENT CONTROL MEASURES SHALL BE REMOVED WITHIN 30 DAYS AFTER FINAL SITE STABILIZATION IS ACHIEVED OR AFTER THE TEMPORARY MEASURES ARE NO LONGER NEEDED.
- THE EROSION CONTROL MEASURES INDICATED ON THE PLANS ARE THE MINIMUM REQUIREMENTS. ADDITIONAL MEASURES MAY BE REQUIRED, AS DIRECTED BY THE ENGINEER, ENFORCEMENT OFFICER, OR OTHER GOVERNING AGENCY.

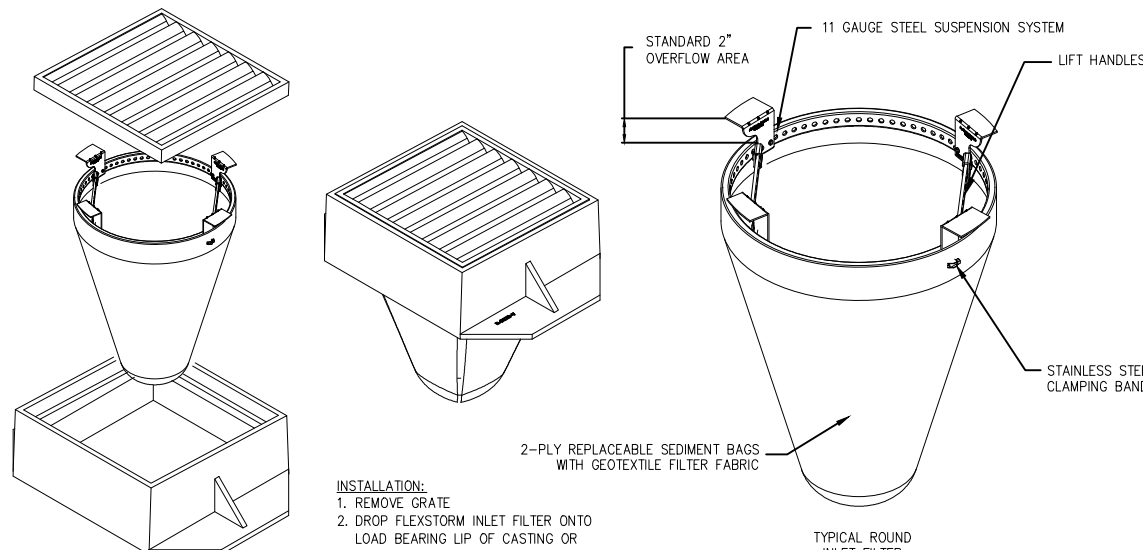

INSTALLATION:
1. REMOVE GRATE
2. DROP FLEXSTORM INLET FILTER ONTO LOAD BEARING LIP OF CASTING OR CONCRETE STRUCTURE
3. REPLACE GRATE

- NOTES:**
- FILTER FABRIC INLET PROTECTION SHALL CONSIST OF INLET BASKET AND FABRIC INSERT, FLEXSTORM CATCH-IT BY ADVANCED DRAINAGE SYSTEMS, FLOGARD TEMPORARY INLET FILTER BY OLDCASTLE, OR APPROVED EQUAL.
 - DEVICE SHALL BE EQUIPPED WITH AN OVERFLOW FEATURE SO DRAINAGE TO INLET IS NOT COMPLETELY BLOCKED IF DEVICE IS FULL OF SILT.
 - INLET BASKET IS AVAILABLE TO FIT ROUND, RECTANGULAR, BEEHIVE OR CURB INLET CASTINGS.
 - FILTER FABRIC SHALL HAVE AN APPARENT OPENING SIZE (AOS) OF AT LEAST 70 SIEVE FOR NONWOVEN.
 - FILTER FABRIC SHALL HAVE A GRAB TENSILE STRENGTH OF A LEAST 100 LBS FOR NON WOVEN.
 - POLYESTER OUTER REINFORCEMENT BAG SHALL HAVE FABRIC WITH A WEIGHT OF 4.55 OZ/SQYD +/- 15 PERCENT.
 - FRAME CONSTRUCTION SHALL HAVE A TENSILE STRENGTH OF AT LEAST 58,000 PSI AND A YIELD STRENGTH OF AT LEAST 36,000 PSI.
 - MAINTENANCE SHALL BE PERFORMED AS NEEDED. REMOVE SILT FROM FABRIC INSERT WHEN 50% OF CAPACITY IS REACHED. REMOVE SILT FROM INTERIOR AND EXTERIOR OF INLET DAM WHEN 50% OF DAM HEIGHT IS REACHED.
 - PAYMENT FOR INLET PROTECTION MAINTENANCE SHALL BE INCIDENTAL TO INLET PROTECTION.

INLET PROTECTION AT MANHOLES IN IMPERVIOUS AREAS

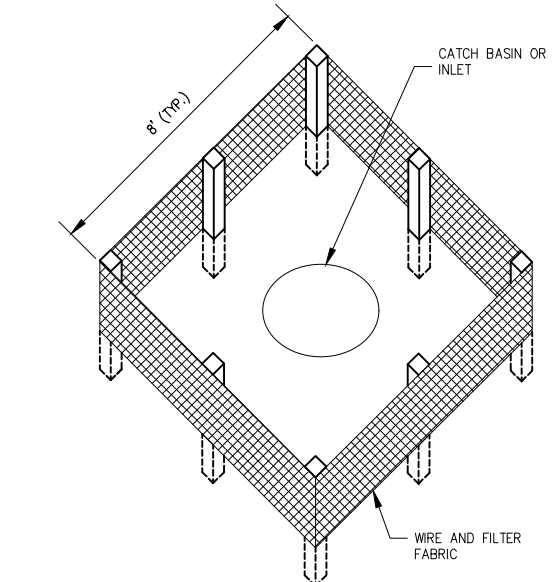

- NOTES:**
- FILTER FABRIC SHALL BE EMBEDDED 8" INTO THE SOIL.
 - INSPECTION SHALL BE FREQUENT AND REPAIR/REPLACEMENT SHALL BE MADE PROMPTLY AS NEEDED.
 - SILT FENCE SHALL BE REMOVED WHEN IT HAS SERVED ITS USEFULNESS AT THE DIRECTION OF THE AIRPORT REPRESENTATIVE OR OWNER SO AS NOT TO BLOCK OR IMPEDE STORM FLOW OR DRAINAGE. CONTRACTOR SHALL PLACE SEED AND MULCH AROUND STRUCTURES PER LANDSCAPING PLAN. COST OF REMOVAL SHALL BE INCLUDED IN THE CONTRACT UNIT PRICE FOR SILT FENCE.
 - AREAS DISTURBED OUTSIDE OF CONSTRUCTION LIMITS DURING PLACEMENT OF INLET PROTECTION TO BE RE-GRADED, SEEDED AND MULCHED, COST INCIDENTAL TO SILT FENCE.
 - FENCE AND POSTS SHALL BE REMOVED WHEN DIRECTED AT PROJECT END.
 - PAID UNDER AR156510 SILT FENCE

SILT FENCE AT MANHOLES IN PVIOUS AREAS

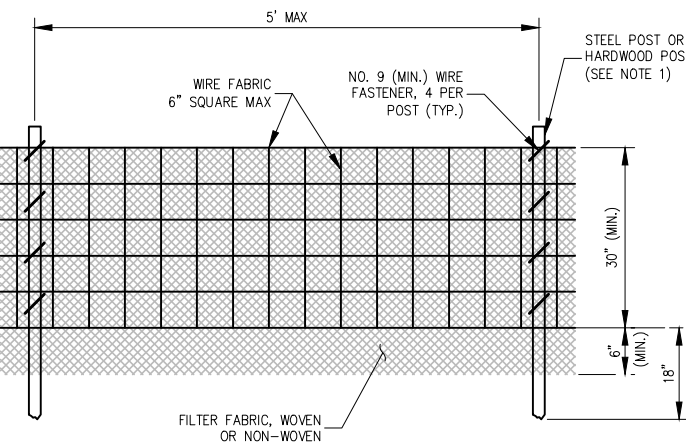
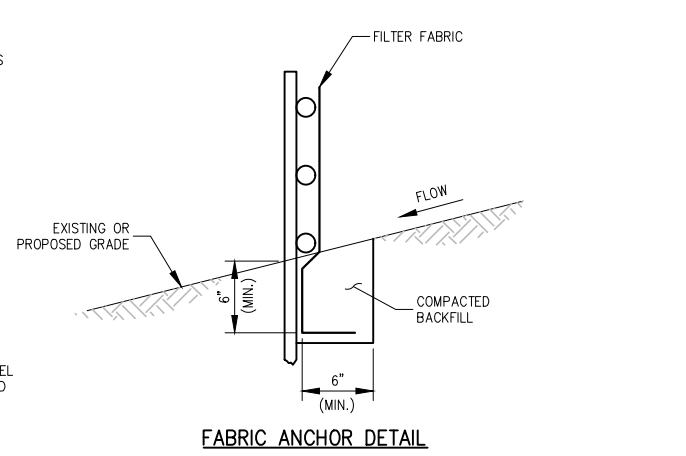

ELEVATION

- NOTES:**
- FENCE POST SHALL BE EITHER STEEL "T" LINE POST OR HARDWOOD POST WITH A MINIMUM SECTIONAL AREA OF 2.0 SQUARE INCHES. A CARPENTER'S (NOMINAL) 2"x2" POST WILL MEET SPECIFICATIONS.
 - TOP AND BOTTOM WIRE OF WIRE FABRIC SHALL BE MINIMUM GAGE NO. 9. INTERMEDIATE WIRES OF THE WIRE FABRIC SHALL BE MINIMUM GAGE NO. 11.
 - WIRE FABRIC SHALL BE SECURELY FASTENED TO FENCE POSTS WITH NO. 9 GAGE WIRE MINIMUM. FOUR (4) FASTENERS PER POST REQUIRED.
 - FILTER FABRIC SHALL BE SECURELY FASTENED TO WIRE FABRIC AND POSTS WITH TIES OR STAPLES SPACED AT 12" APART AT THE TOP, MIDDLE AND BOTTOM.
 - WHEN TWO SECTIONS OF FILTER FABRIC MEET, THEY SHALL BE OVERLAPPED BY 6" AND FOLDED AND ATTACHED TO THE WIRE FABRIC AT A POST.
 - FILTER FABRIC SHALL BE IN ACCORDANCE WITH SPECIAL PROVISIONS WITH APPARENT OPENING SIZE (AOS) OF AT LEAST 40 FOR NONWOVEN AND WOVEN (OR MAXIMUM OF 0.60mm). **THE FABRIC MUST MEET THE APPLICABLE STANDARDS OF AASHTO 288-00 (Article IV, Section B.1.j.1.i, AS AMENDED), OR EQUIVALENT.**
 - A MAXIMUM OF 5 FEET IS USED FOR POST-TO-POST SPACING.
 - SOIL DISTURBANCE SHALL BE CONDUCTED IN SUCH A MANNER AS TO MINIMIZE EROSION. SOIL STABILIZATION MEASURES SHALL CONSIDER THE TIME OF YEAR, SITE CONDITIONS AND THE USE OF TEMPORARY OR PERMANENT MEASURES.
 - ALL STORM SEWERS THAT ARE OR WILL BE FUNCTIONING DURING CONSTRUCTION SHALL BE PROTECTED BY AN APPROPRIATE SEDIMENT CONTROL MEASURE.
 - SILT FENCE SHALL BE INSTALLED PRIOR TO ANY GRADING WORK IN THE AREA TO BE PROTECTED. PERIODIC INSPECTION SHALL BE PERFORMED AND REQUIRED MAINTENANCE SHALL BE PROVIDED AFTER EACH RAIN EVENT.
 - MAINTENANCE SHALL BE PERFORMED AS NEEDED AND MATERIAL REMOVED AND REPLACED WHEN BULGES DEVELOP IN THE SILT FENCE.
 - IF DEWATERING SERVICES ARE USED, ADJOINING PROPERTIES AND DISCHARGE LOCATIONS SHALL BE PROTECTED FROM EROSION. DISCHARGES SHALL BE ROUTED THROUGH AN EFFECTIVE SEDIMENT CONTROL MEASURE (E.G. SEDIMENT TRAP, SEDIMENT BASIN, OR OTHER APPROPRIATE MEASURE).
 - FENCE POSTS SHALL BE REMOVED WHEN DIRECTED AT PROJECT END.
 - THE EROSION CONTROL MEASURES INDICATED ON THE PLANS ARE THE MINIMUM REQUIREMENTS. ADDITIONAL MEASURES MAY BE REQUIRED, AS DIRECTED BY THE ENGINEER OR GOVERNING AGENCY.

STORM WATER POLLUTION PREVENTION NOTES

GENERAL
THE CONTRACTOR SHALL IMPLEMENT ALL PROVISIONS OF THE CONTRACT DOCUMENTS TO ASSURE THAT STORM WATER POLLUTION PREVENTION ITEMS ARE CONSTRUCTED AND MAINTAINED IN A TIMELY MANNER. SEDIMENTATION MUST NOT BE TRANSPORTED OFF THE CONSTRUCTION SITE. PERMANENT DRAINAGE FEATURES AND VEGETATIVE MEASURES SHALL BE PROVIDED AS SOON AS POSSIBLE.

THE MAINTENANCE OF ALL STORM WATER POLLUTION PREVENTION MEASURES IS INCIDENTAL TO THE ASSOCIATED ITEM.

POLLUTION PREVENTION MEASURES
THE CONTRACTOR SHALL BE REQUIRED TO IMPLEMENT AND MAINTAIN STORM WATER POLLUTION PREVENTION PRACTICES AND MEASURES PRIOR TO THE STRIPPING OF EXISTING VEGETATION WHEREVER POSSIBLE AND AS SOON AS CONSTRUCTION PERMITS IN OTHER AREAS. POLLUTION CONTROL MEASURES SHALL BE IN ACCORDANCE WITH THE CONTRACT DOCUMENTS, INCLUDING THESE CONSTRUCTION PLANS, AND WITH **STANDARDS AND SPECIFICATIONS FOR SOIL EROSION AND SEDIMENT CONTROL**, ILLINOIS ENVIRONMENTAL PROTECTION AGENCY, CURRENT ISSUE. THE CONTRACTOR SHALL ADJUST HIS OPERATIONS AND IMPLEMENT POLLUTION CONTROL MEASURES SO THAT NO RUNOFF FROM STRIPPED AREAS WILL LEAVE THE CONSTRUCTION SITE OTHER THAN THROUGH SEDIMENT TRAPS OR OTHER SUITABLE CONTROL MEASURES.

POLLUTION CONTROL ITEMS SHALL BE PROVIDED AS NOTED ON THE STORM WATER POLLUTION PREVENTION PLAN AND IN THE STORM WATER POLLUTION PREVENTION DETAILS AND AS DIRECTED BY THE ENGINEER. THE LIMITS OF SUCH MEASURES SHALL BE STAKED BY THE CONTRACTOR PRIOR TO THE COMMENCEMENT OF CONSTRUCTION. SUCH LIMITS MAY BE ADJUSTED BY THE ENGINEER TO ACCOUNT FOR ACTUAL SITE CONDITIONS EXPERIENCED DURING CONSTRUCTION. ADDITIONAL COMPENSATION FOR MEASURES EXCEEDING THE PLAN QUANTITIES WILL BE PAID FOR AT THE CONTRACT UNIT PRICE FOR EACH ITEM.

THE CONTRACTOR IS TO MAINTAIN AND ADJUST, REPAIR OR REPLACE ALL POLLUTION PREVENTION MEASURES AS REQUIRED OR AS DIRECTED BY THE ENGINEER UNTIL PERMANENT VEGETATION HAS BEEN ESTABLISHED. MAINTENANCE OF POLLUTION CONTROL MEASURES IS TO BE PROVIDED AT NO ADDITIONAL COST TO THE CONTRACT.

ADDITIONAL STORMWATER POLLUTION PREVENTION MEASURES ARE EXISTING ON SITE LOCATED AT DRAINAGE FACILITIES AND ALONG THE PROPERTY LINE.

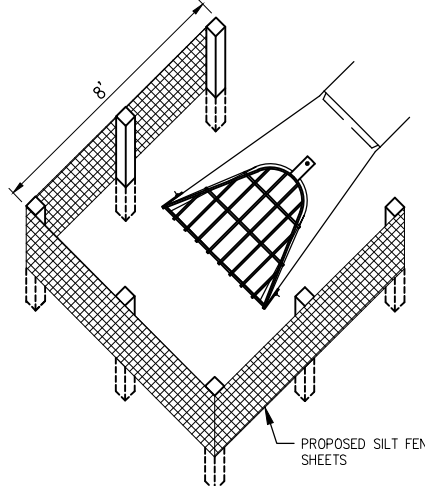

SILT FENCE PLACEMENT AT FLARED END SECTIONS (FES)

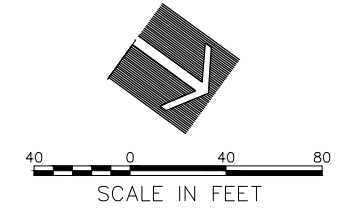

SEE LEGEND, SHEET 17

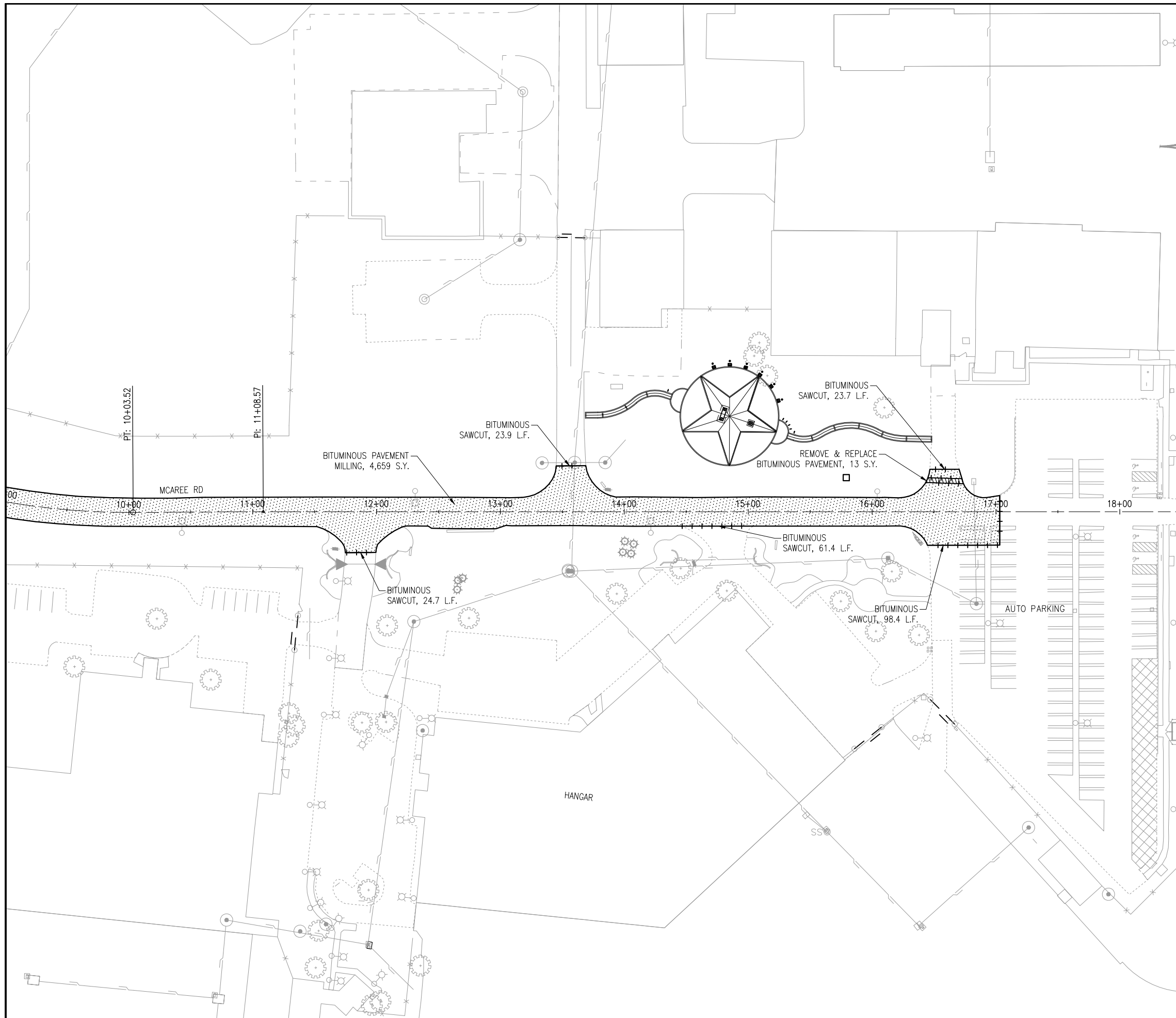

**REHABILITATE AIRPORT
 ENTRANCE ROAD (BASE BID)
 WITH CONSTRUCT SIDEWALK
 (ADDITIVE ALTERNATES)**

IDA No: UGN-4631

WA073

MARK	DATE	DESCRIPTION		
		DES	DRN	REV

ISSUE:
 PROJECT NO: 17A0077
 CAD FILE: 17-REMOVAL PLAN.DWG
 DESIGN BY: LDH
 DRAWN BY: SCS
 REVIEWED BY: KMS 10/17/18

SHEET TITLE

REMOVAL PLAN

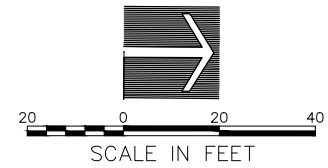
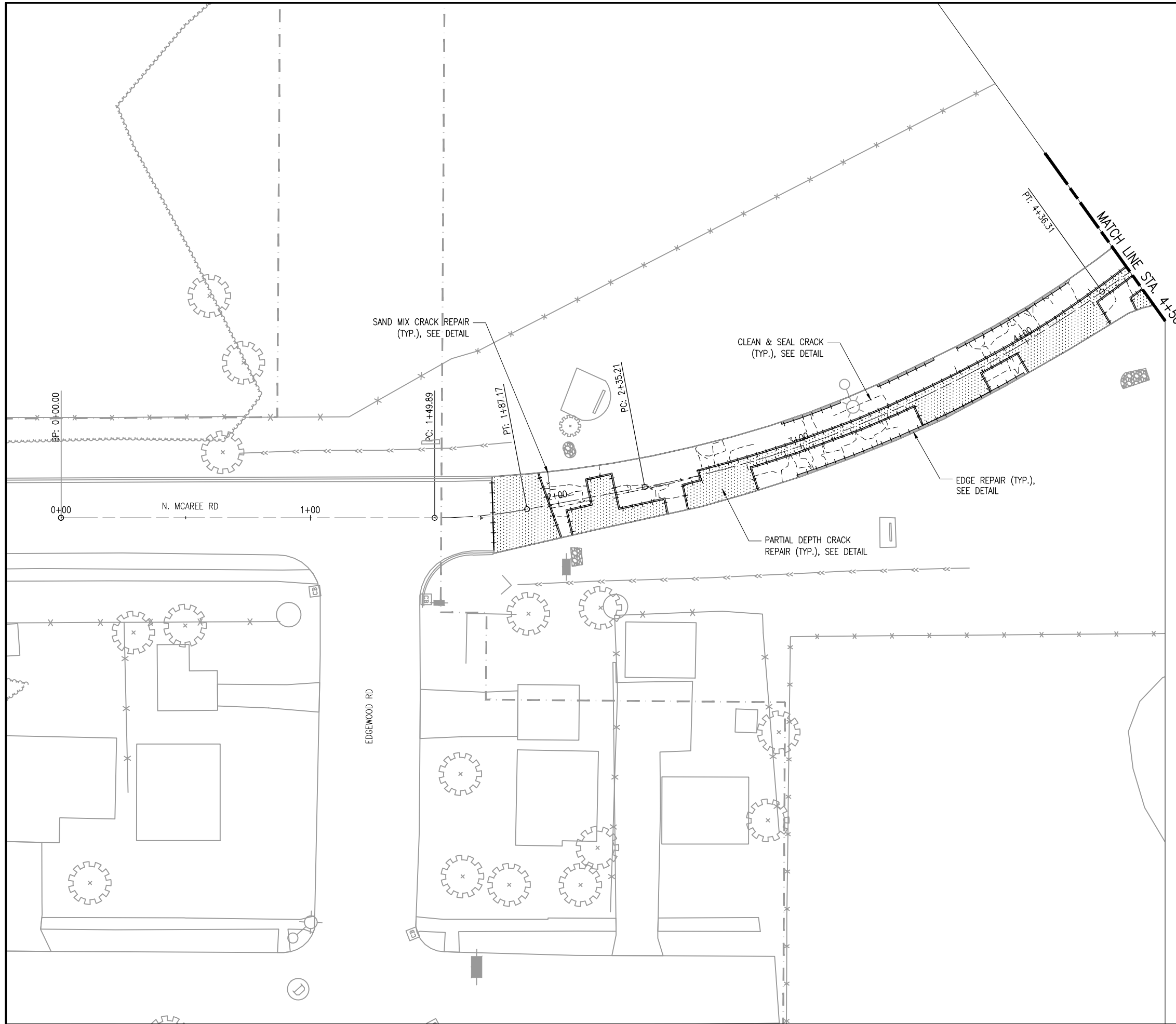

LEGEND

- CLEAN AND SEAL, TYPE A CRACK
- x-x- SAND MIX AND CRACK REPAIR, TYPE B CRACK
- [Stippled Area] PARTIAL DEPTH REPAIR, TYPE C CRACK AND ALLIGATOR CRACKING AREAS
- [Solid Grey Area] PAVEMENT EDGE REPAIR
- ++++ SAWCUT REQUIRED FOR CRACK REPAIR

NOTES

1. FOR ALIGNMENT DATA TABLE SEE SHEET 12.
2. FOR CRACK REPAIR DETAILS SEE SHEET 13.
3. THE WORK QUANTITIES FOR AR201661 CLEAN AND SEAL BITUMINOUS CRACKS AND AR201663 SAND MIX CRACK REPAIR ASSUME THAT 90 PERCENT OF THE TYPE A CRACKS AND 50 PERCENT OF THE TYPE B CRACKS ARE ELIMINATED DURING THE 2 INCH SURFACE REMOVAL UNDER ITEM AR401650. THE ACTUAL LOCATION AND QUANTITY OF CRACKS TO BE REPAIRED SHALL BE DETERMINED BY THE RESIDENT ENGINEER AFTER MILLING OPERATIONS. CONTRACTOR SHALL PERFORM THE WORK AS DIRECTED BY THE RESIDENT ENGINEER AND SHALL NOT BE ENTITLED TO OR MAKE ANY CLAIM FOR ADDITIONAL COMPENSATION IF THE ACTUAL QUANTITY PERFORMED IS MORE OR LESS THAN THE BID QUANTITY ESTIMATED FOR EACH REPAIR ITEM.

REHABILITATE AIRPORT ENTRANCE ROAD (BASE BID) WITH CONSTRUCT SIDEWALK (ADDITIVE ALTERNATES)

IDA No: UGN-4631

WA073

MARK	DATE	DESCRIPTION		
		DES	DRN	REV

ISSUE:
PROJECT NO: 17A0077
CAD FILE: 19-CRACK REPAIR.DWG
DESIGN BY: LDH
DRAWN BY: SCS
REVIEWED BY: KMS 10/17/18

SHEET TITLE

**CRACK REPAIR PLAN
STA. 1+00 - 4+50**

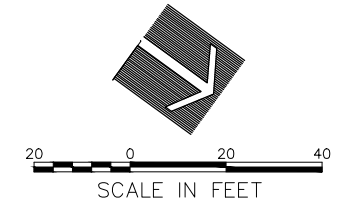

FOR NOTES AND LEGEND, SEE SHEET 19.

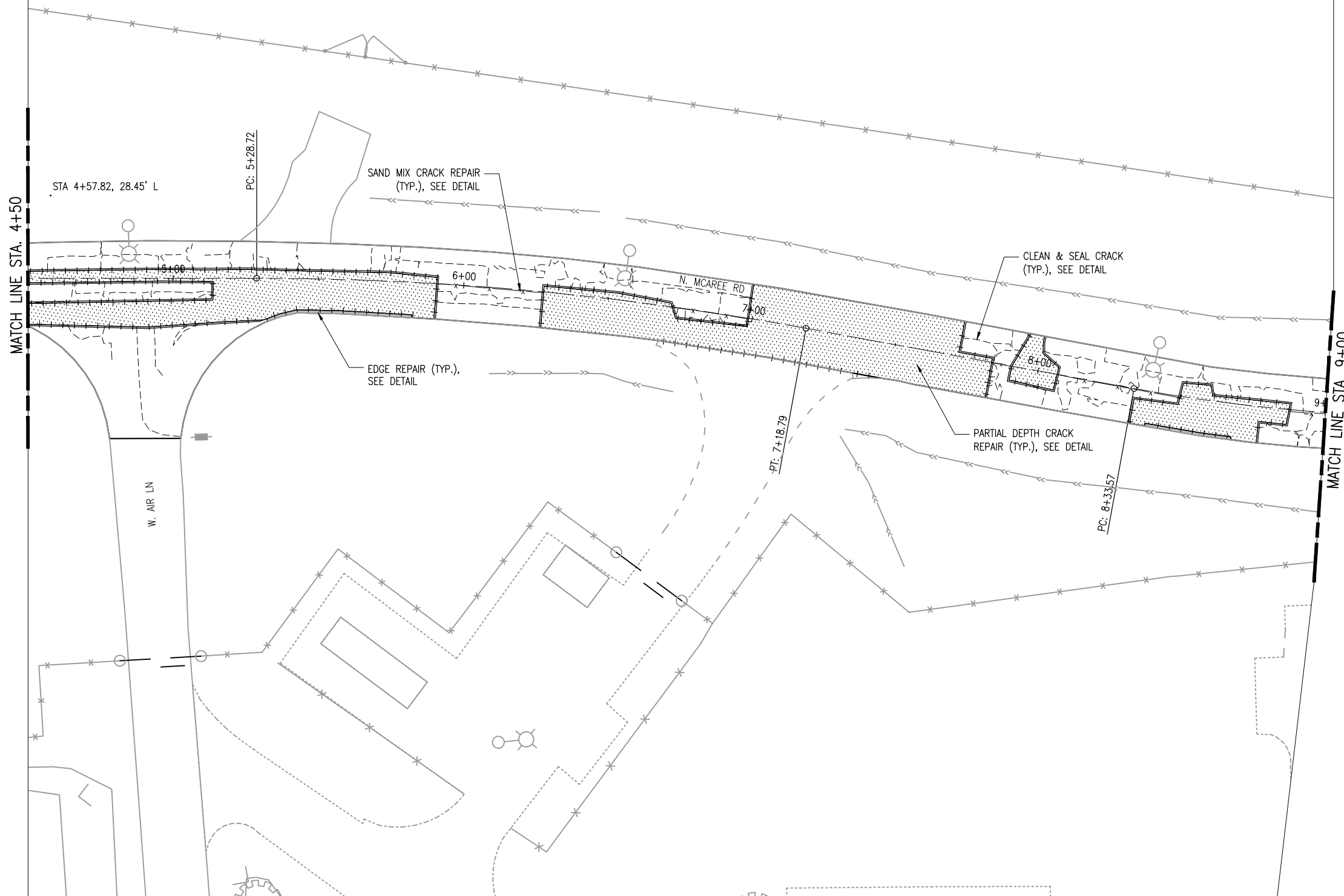

REHABILITATE AIRPORT
 ENTRANCE ROAD (BASE BID)
 WITH CONSTRUCT SIDEWALK
 (ADDITIVE ALTERNATES)

IDA No: UGN-4631

WA073

MARK	DATE	DESCRIPTION		
		DES	DRN	REV

ISSUE:
 PROJECT NO: 17A0077
 CAD FILE: 19-CRACK REPAIR.DWG
 DESIGN BY: LDH
 DRAWN BY: SCS
 REVIEWED BY: KMS 10/17/18

SHEET TITLE

CRACK REPAIR PLAN
 STA. 4+50 - 9+00

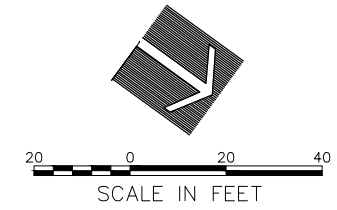

FOR NOTES AND LEGEND, SEE SHEET 19.

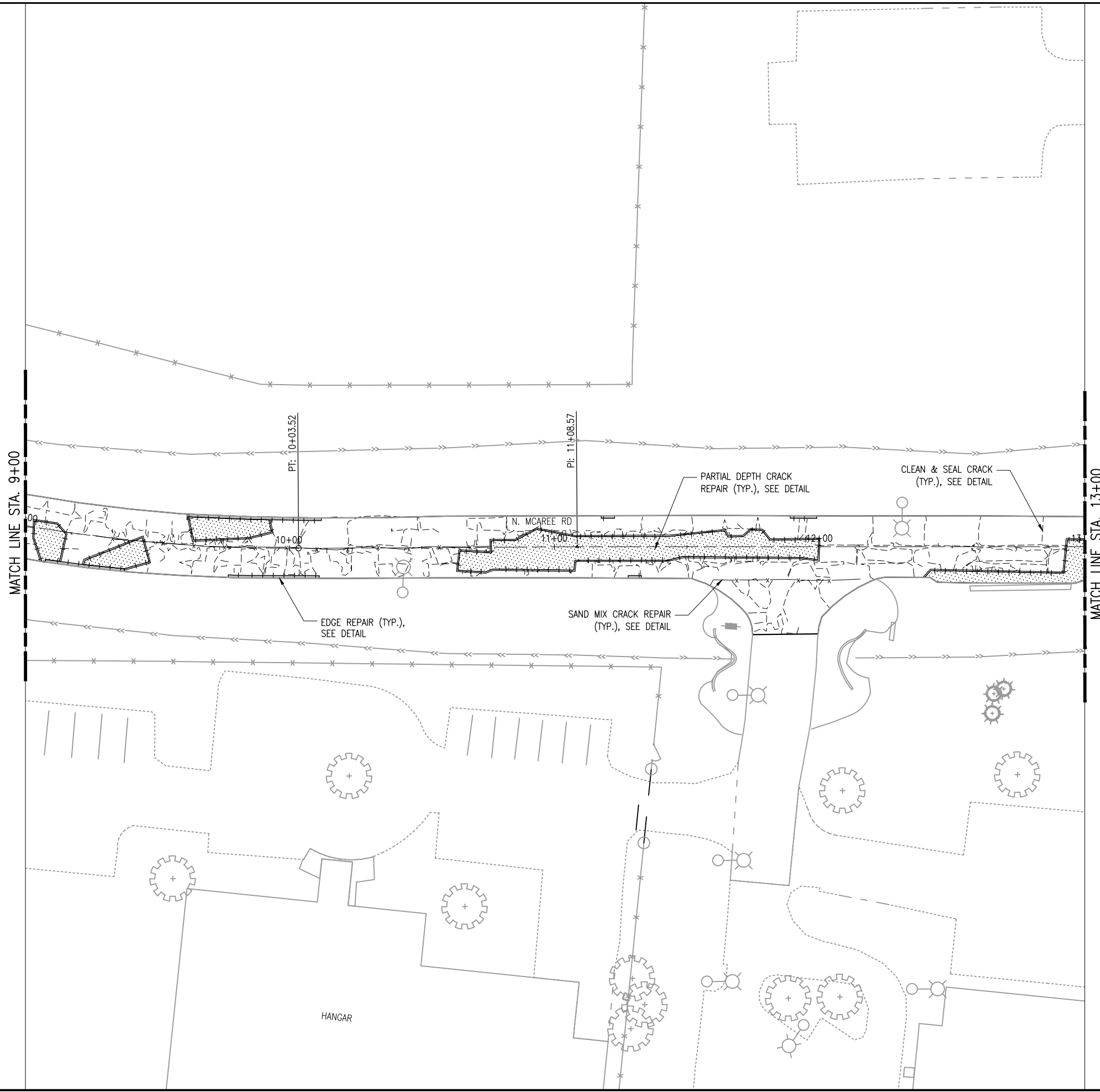

REHABILITATE AIRPORT
 ENTRANCE ROAD (BASE BID)
 WITH CONSTRUCT SIDEWALK
 (ADDITIVE ALTERNATES)

IDA No: UGN-4631

WA073

MARK	DATE	DESCRIPTION		
		DES	DRN	REV

ISSUE:
 PROJECT NO: 17A0077
 CAD FILE: 19-CRACK REPAIR.DWG
 DESIGN BY: LDH
 DRAWN BY: SCS
 REVIEWED BY: KMS 10/17/18

SHEET TITLE

CRACK REPAIR PLAN
 STA. 9+00 - 13+00

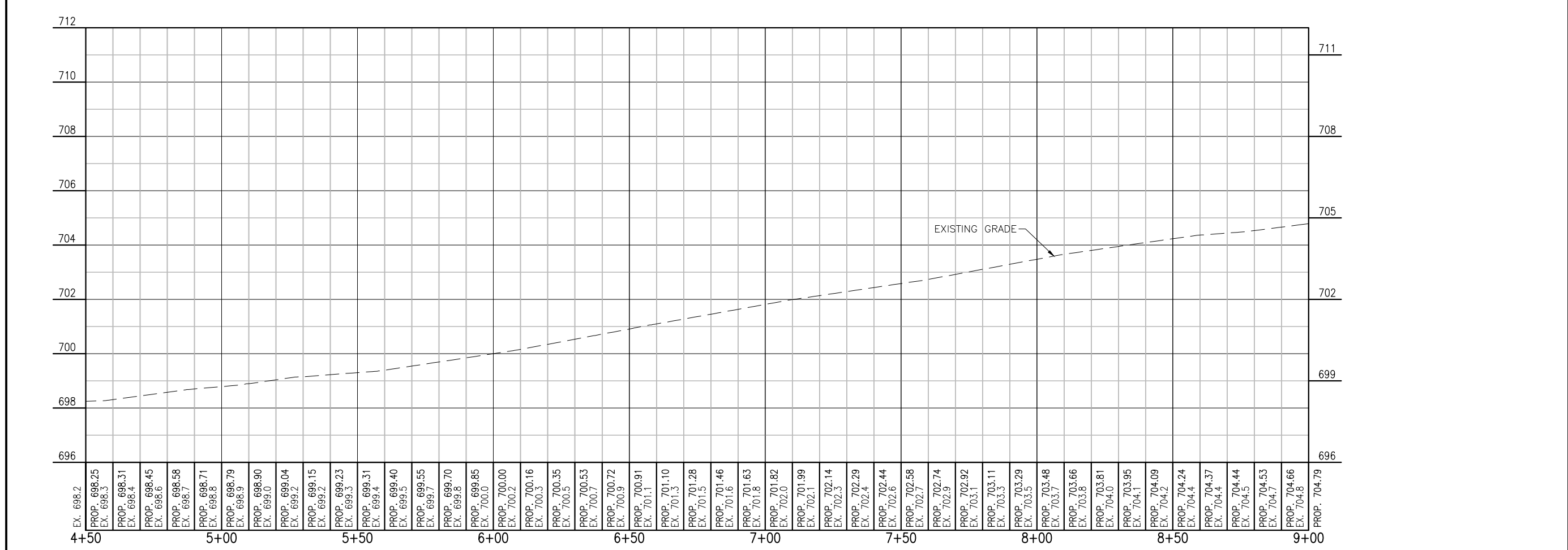
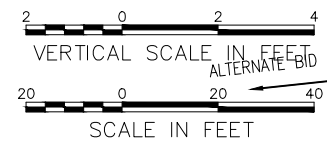
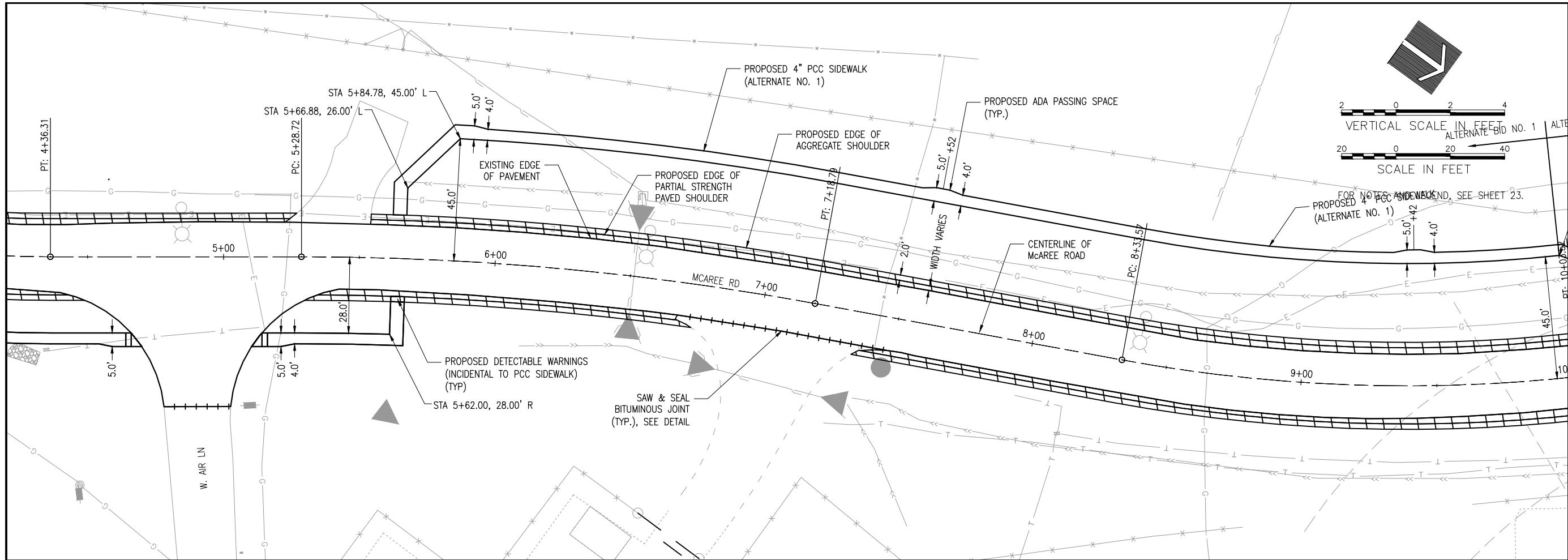

REHABILITATE AIRPORT
ENTRANCE ROAD (BASE BID)
WITH CONSTRUCT SIDEWALK
(ADDITIVE ALTERNATES)

IDA No: UGN-4631

WA073

MARK	DATE	DESCRIPTION		
		DES	DRN	REV

ISSUE:
PROJECT NO: 17A0077
CAD FILE: 23-P&PROFILE.DWG
DESIGN BY: LDH
DRAWN BY: SCS
REVIEWED BY: KMS 10/17/18

SHEET TITLE

PLAN AND PROFILE
STA. 4+50 - 9+00



WAUKEGAN NATIONAL AIRPORT
WAUKEGAN PORT DISTRICT
2601 Plane Rest Drive
Waukegan, Illinois 60087
Telephone: 847.244.0055
Fax: 847.244.3813

REHABILITATE AIRPORT
ENTRANCE ROAD (BASE BID)
WITH CONSTRUCT SIDEWALK
(ADDITIVE ALTERNATES)

IDA No: UGN-4631

WA073

MARK	DATE	DESCRIPTION		
		DES	DRN	REV

ISSUE:
PROJECT NO: 17A0077
CAD FILE: 27-CROSSSECTIONS.DWG
DESIGN BY: LDH 05/22/2018
DRAWN BY: LDH 05/22/18
REVIEWED BY: KMS 10/17/18

SHEET TITLE

CROSS SECTIONS
4+50 TO 7+00

EARTHWORK SUMMARY IN CUBIC YARDS (ALTERNATE BID #1)

CUT		
Topsil	55	
Suitable Material	42	
TOTAL UNCLASSIFIED CUT	97	
TOPSOIL FILL		
Topsil from Off Site	19	
TOTAL TOPSOIL REQUIRED	19	

* Haul and disposal costs are incidental to Unclassified Excavation.

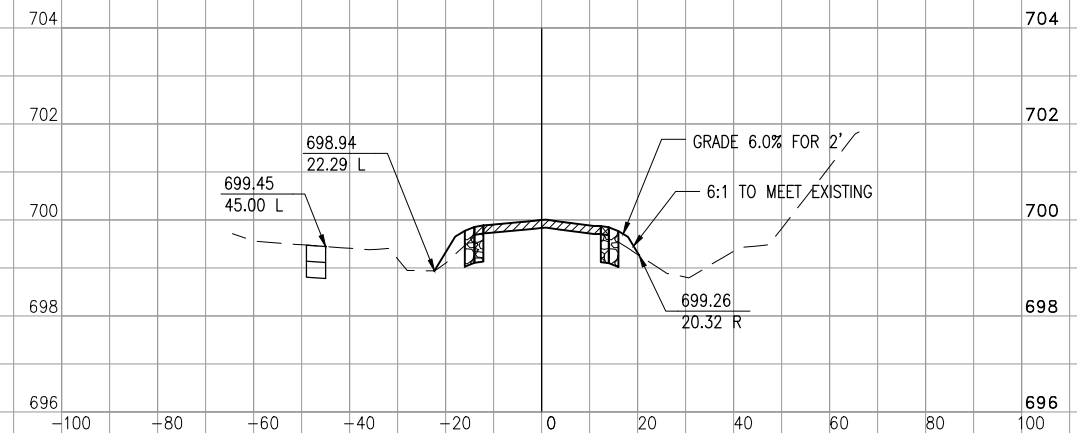
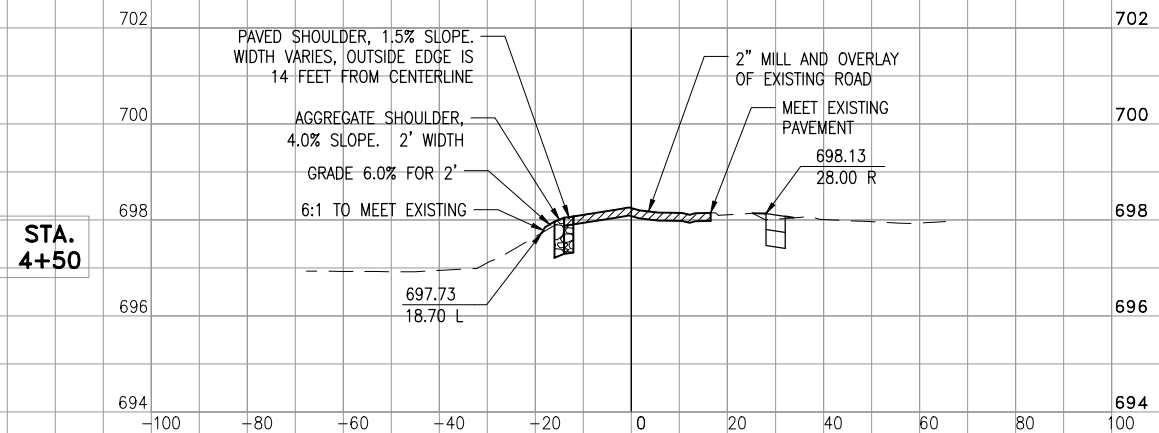
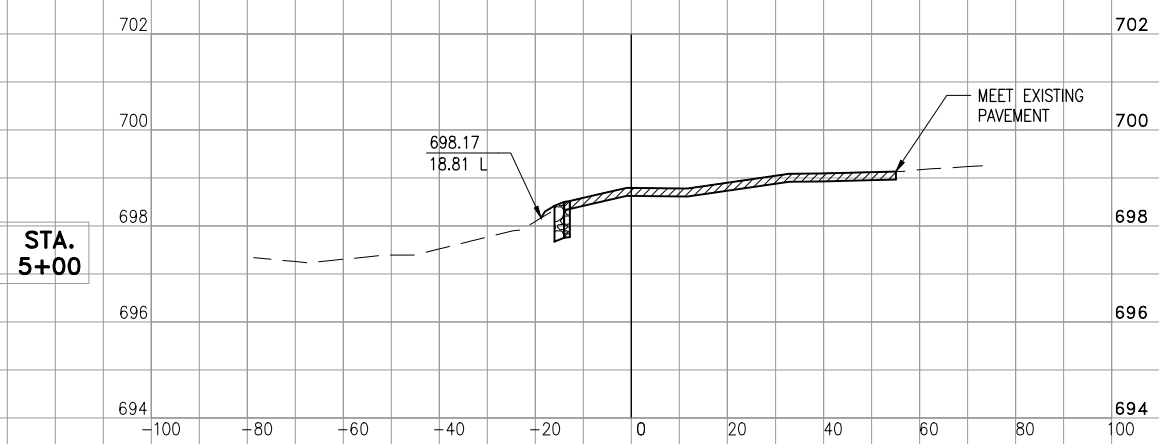
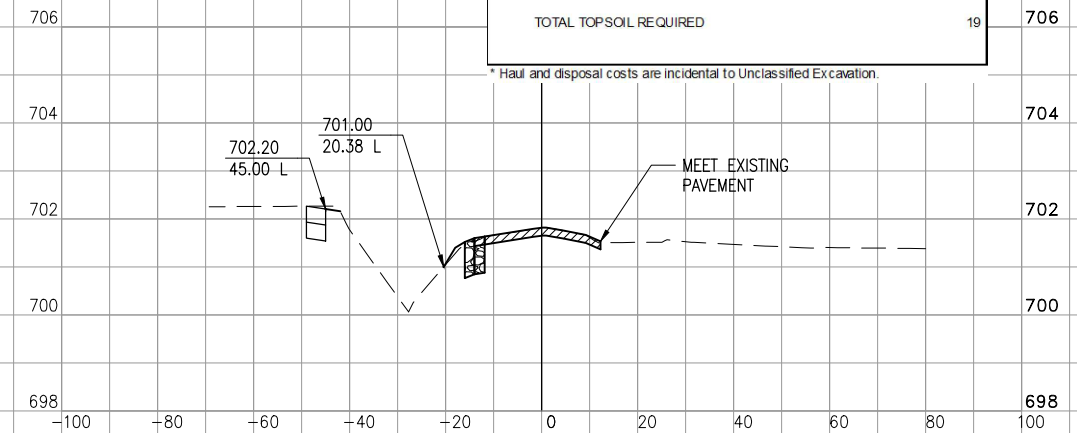
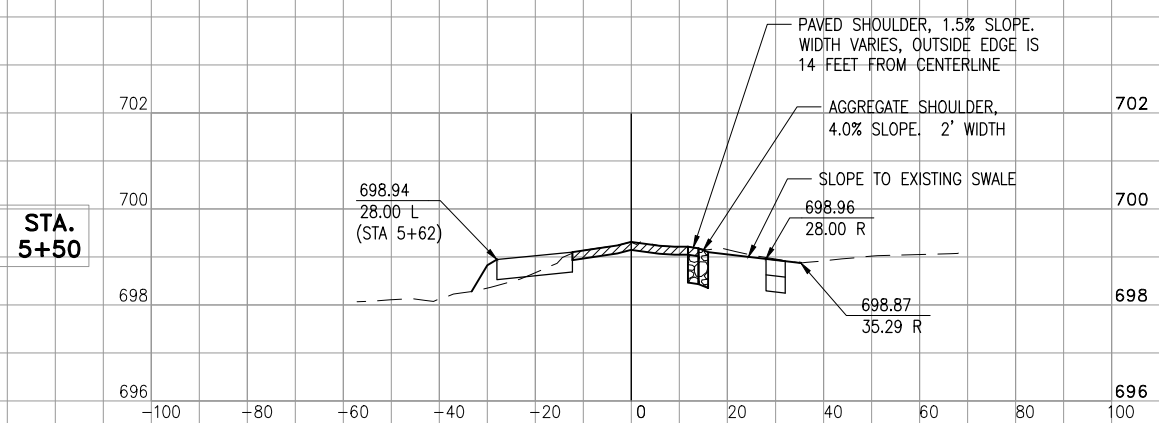

Hanson Professional Services Inc.
750 Warrenville Road
Lisle, IL 60532
phone: 630-990-3800
fax: 630-990-3801
Offices Nationwide
www.hanson-inc.com

Illinois Licensed
Professional Service Corporation
#184-001084



WAUKEGAN NATIONAL AIRPORT
WAUKEGAN PORT DISTRICT
2601 Plane Rest Drive
Waukegan, Illinois 60087
Telephone: 847.244.0055
Fax: 847.244.3813

EARTHWORK SUMMARY IN CUBIC YARDS (ALTERNATE BID 2)		
CUT	Topsail	43
	Suitable Material	22
TOTAL UNCLASSIFIED CUT		65
TOPSOIL FILL	Topsail from Off Site	13
	TOTAL TOPSOIL REQUIRED	13

* Haul and disposal costs are incidental to Unclassified Excavation.

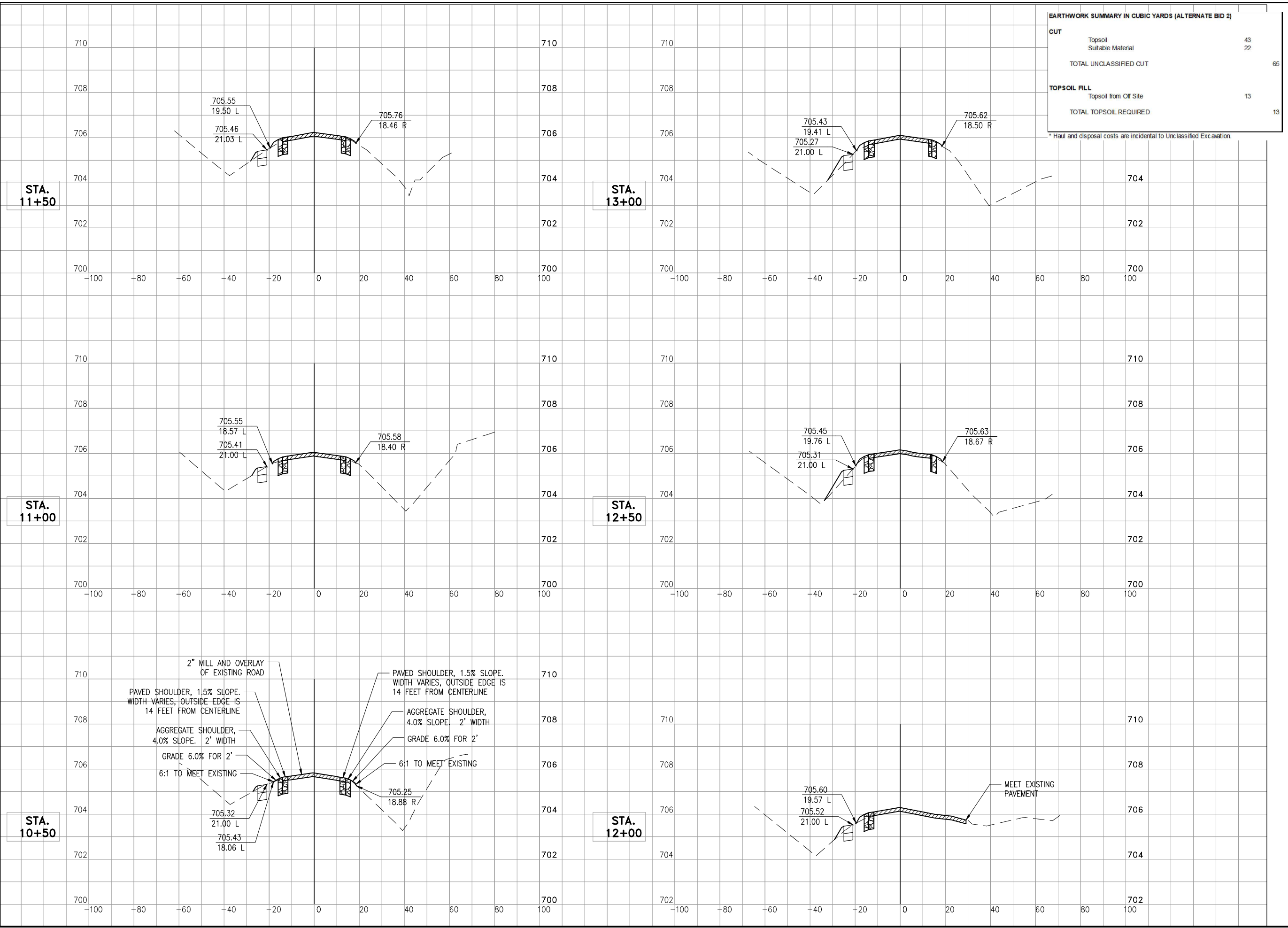

REHABILITATE AIRPORT
ENTRANCE ROAD (BASE BID)
WITH CONSTRUCT SIDEWALK
(ADDITIVE ALTERNATES)

IDA No: UGN-4631

WA073

MARK	DATE	DESCRIPTION		
		DES	DRN	REV

ISSUE:
PROJECT NO: 17A0077
CAD FILE: 27-CROSSSECTIONS.DWG
DESIGN BY: LDH 05/22/18
DRAWN BY: LDH 05/22/18
REVIEWED BY: KMS 10/17/18

SHEET TITLE

CROSS SECTIONS
10+50 TO 13+00

Hanson Professional Services Inc.
 750 Warrenville Road
 Lisle, IL 60532
 phone: 630-990-3800
 fax: 630-990-3801
 Offices Nationwide
 www.hanson-inc.com

Illinois Licensed
 Professional Service Corporation
 #184-001084



WAUKEGAN NATIONAL AIRPORT
 WAUKEGAN PORT DISTRICT
 2601 Plane Rest Drive
 Waukegan, Illinois 60087
 Telephone: 847.244.0055
 Fax: 847.244.3813

REHABILITATE AIRPORT
 ENTRANCE ROAD (BASE BID)
 WITH CONSTRUCT SIDEWALK
 (ADDITIVE ALTERNATES)

IDA No: UGN-4631

WA073

MARK	DATE	DESCRIPTION		
		DES	DRN	REV

ISSUE:
 PROJECT NO: 17A0077
 CAD FILE: 27-CROSSSECTIONS.DWG
 DESIGN BY: LDH 05/22/18
 DRAWN BY: LDH 05/22/18
 REVIEWED BY: KMS 10/17/18

SHEET TITLE

CROSS SECTIONS
 16+50 TO 17+03

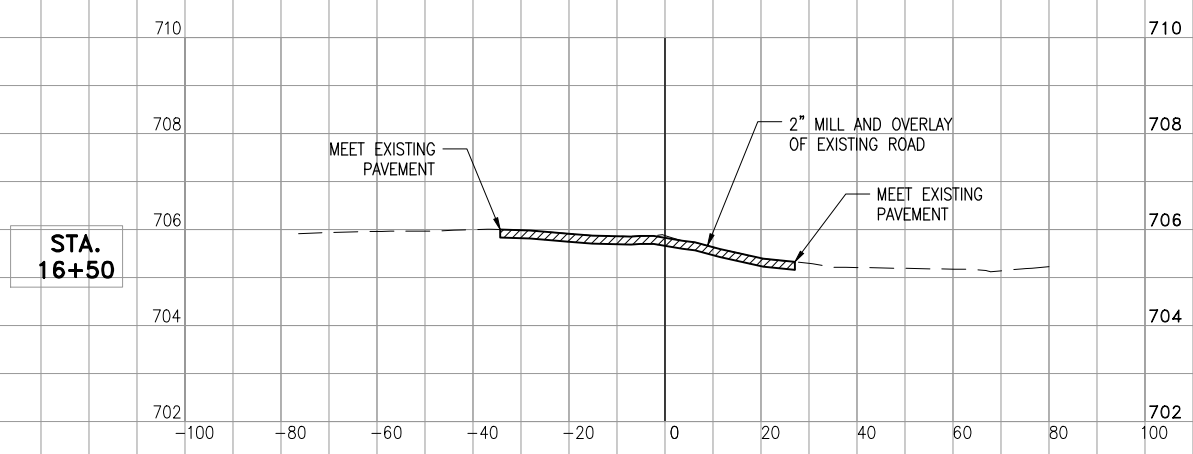
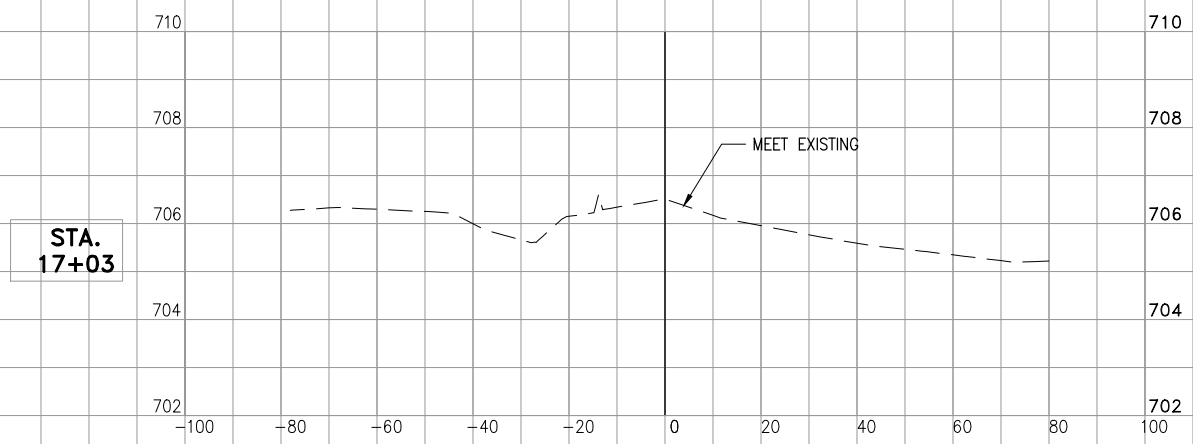

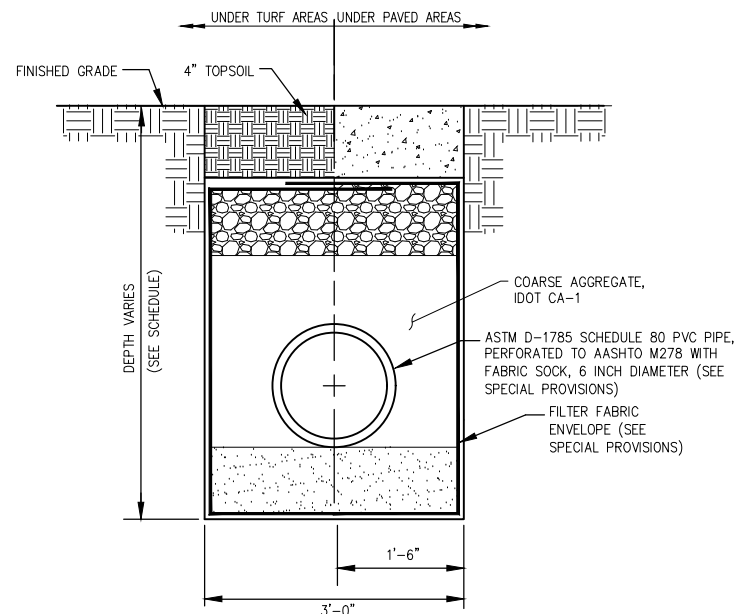

NOTES

1. UNSUITABLE MATERIAL ENCOUNTERED DURING PLACEMENT OF BEDDING SHALL BE REMOVED AND REPLACED.
2. DO NOT COMPACT SOIL PLACED ABOVE THE AGGREGATE.
3. SEPARATE PAYMENT FOR COARSE AND FINE AGGREGATES, FILTER FABRIC ENVELOPE, PVC PIPE, AND FABRIC SOCK WILL NOT BE MADE BUT SHALL BE INCLUDED IN THE CONTRACT UNIT PRICE PER LINEAR FOOT OF INFILTRATION TRENCH.
4. SEE SPECIAL PROVISIONS.

INFILTRATION TRENCH

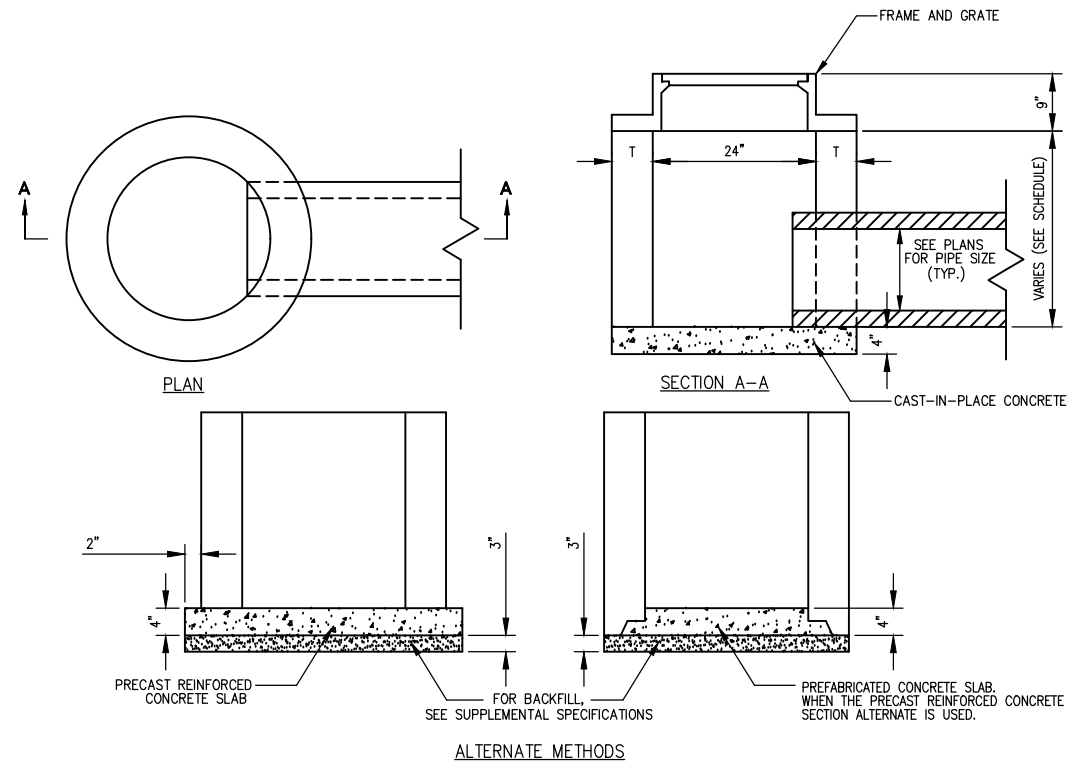

NOTES

1. SEE DRAINAGE AND UNDERDRAIN SCHEDULE FOR LOCATION, SIZE AND NUMBER OF PIPE CONNECTIONS.
2. INLETS TO BE PRECAST REINFORCED CONCRETE SECTIONS (T = 5").

INLET TYPE A

(DOT STANDARD 602301)

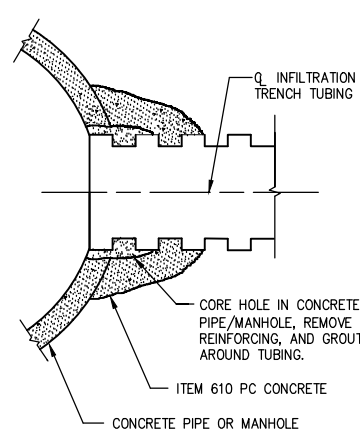

STORM SEWER CONCRETE COLLAR AND GROUT CONNECTION

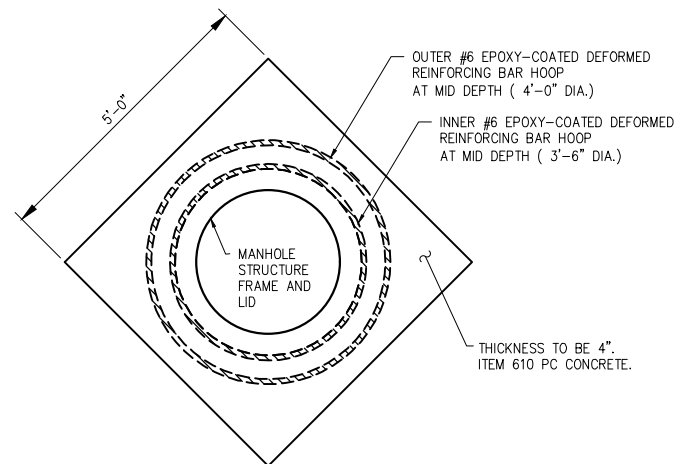

FRAMING NOTES

1. HOOP REINFORCEMENT REQUIRED AND SHALL BE ONE PIECE CONSTRUCTION HAVING A MINIMUM LAP LENGTH OF 2'-0".
2. CONCRETE COLLAR IS INCIDENTAL TO INLET

CONCRETE COLLAR AT INLET

INFILTRATION TRENCH SCHEDULE

Structure	Station	Offset	Type	Rim El.	Invert El.	Pipe Pay Length	Size	Type	Slope %
S1	15+79.18	27.5	LT	Inlet - Type A	704.50*	NW	703.41		
S2	16+82.13	24.3	LT	Existing Manhole	---	SE	703.26	100.0	6.0 PVC 0.15

* THIS ELEVATION REPRESENTS THE TOP OF THE FRAME, NOT THE TOP OF THE BEEHIVE GRATE.

STRUCTURE SCHEDULE

Structure Number	Structure Type	Diameter "D" (in.)	Frame Height (in.)	Grate Diameter (in.)	Frame Type (Neenah) *	Cover/Grate (Neenah) *
S1	Inlet - Type A	24	3-15/16	22	R-2560-D1	R-1690

* OTHER COMPARABLE MANUFACTURERS ARE ACCEPTABLE.

REHABILITATE AIRPORT ENTRANCE ROAD (BASE BID) WITH CONSTRUCT SIDEWALK (ADDITIVE ALTERNATES)

IDA No: UGN-4631

WA073

MARK	DATE	DESCRIPTION		
		DES	DRN	REV

ISSUE:
PROJECT NO: 17A0077
CAD FILE: 37-DRAINAGE DET.DWG
DESIGN BY: LDH
DRAWN BY: SCS
REVIEWED BY: KMS 10/17/18

SHEET TITLE

DRAINAGE SCHEDULE & DETAILS

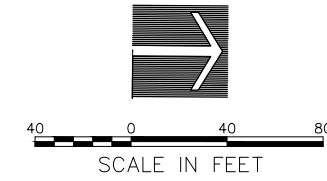

SCALE IN FEET

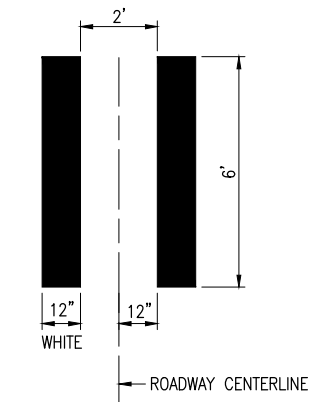

CROSSWALK MARKING DETAIL

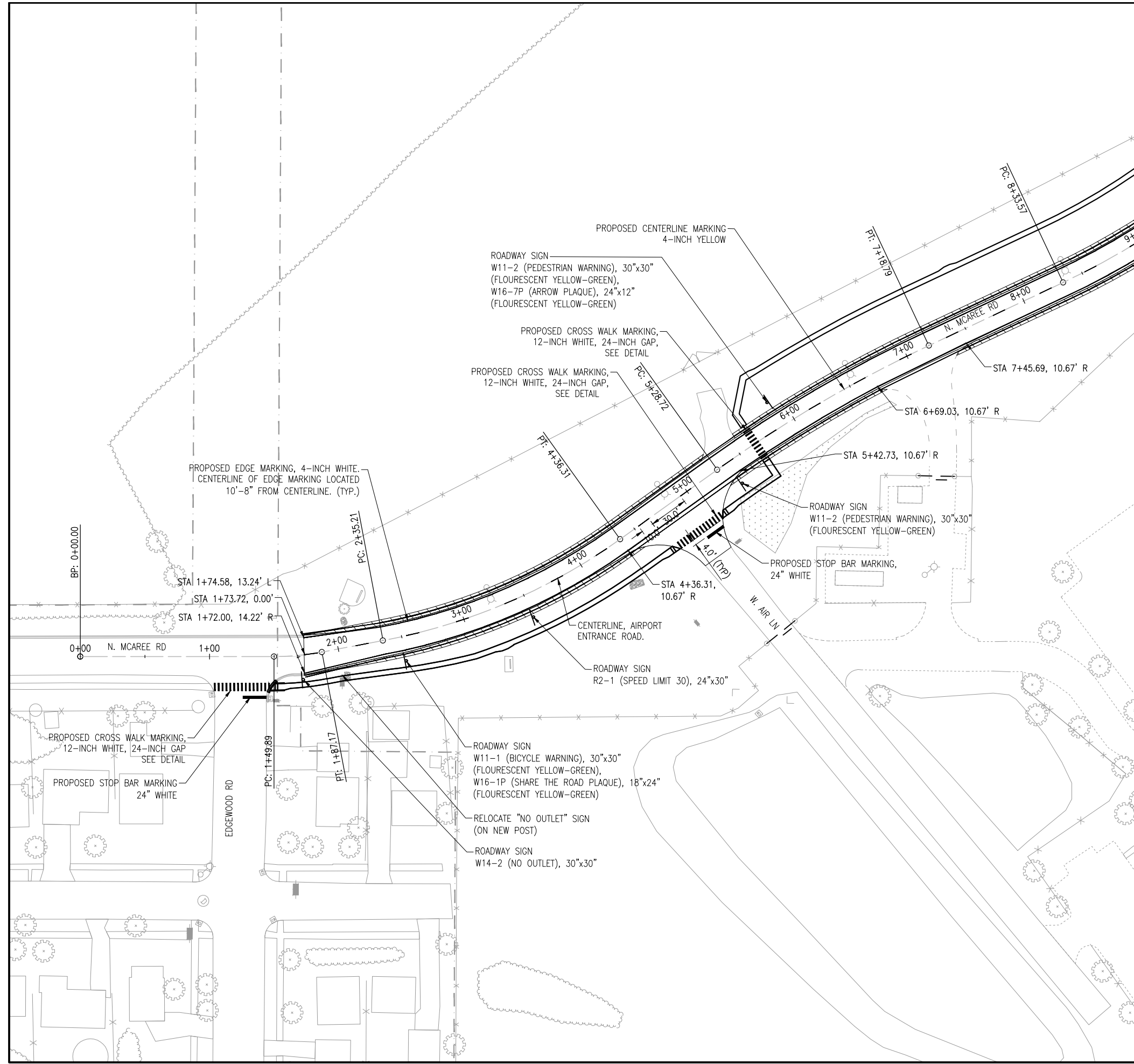

REHABILITATE AIRPORT
ENTRANCE ROAD (BASE BID)
WITH CONSTRUCT SIDEWALK
(ADDITIVE ALTERNATES)

IDA No: UGN-4631

WA073

MARK	DATE	DESCRIPTION		
		DES	DRN	REV

ISSUE:
PROJECT NO: 17A0077
CAD FILE: 38-MARKING.DWG
DESIGN BY: LDH
DRAWN BY: SCS
REVIEWED BY: KMS 10/17/18

SHEET TITLE

MARKING PLAN STA.
0+00 - 9+00

NOTE: REFER TO SECTION 2 OF THE MUTCD FOR GUIDANCE REGARDING
MOUNTING HEIGHT AND LATERAL OFFSETS AT SIGN LOCATIONS
WHERE LATERAL OFFSETS SHOWN IN HWY. STD. 720006 CANNOT
BE ACHIEVED.



WAUKEGAN NATIONAL AIRPORT
 WAUKEGAN PORT DISTRICT
 2601 Plane Rest Drive
 Waukegan, Illinois 60087
 Telephone: 847.244.0055
 Fax: 847.244.3813

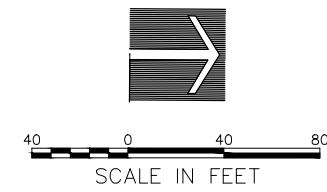

NOTES:

THE CONTRACTOR SHALL LIMIT THE ACREAGE OF DISTURBED GROUND TO ONLY THAT NECESSARY FOR THE CONDUCT OF AN EFFICIENT CONSTRUCTION PROCESS WITHOUT OVER-EXPOSING NON-VEGETATED AREAS. ANY DISTURBED AREA OF CONSTRUCTION THAT WILL NOT BE REWORKED FOR A PERIOD LONGER THAN 14 DAYS MUST BE SEED OR MULCHED, WITH EITHER PERMANENT SEEDING, OR TEMPORARY SEEDING AND MULCHING, ITEM AR156533, AFTER APPROVAL BY THE RESIDENT ENGINEER OF THIS PROPOSED ACTION. THE CONTRACTOR SHALL MAKE BEST EFFORT TO REDUCE THE NEED FOR TEMPORARY COVERING BY SCHEDULING HIS EARTHWORK ACTIVITIES IN A PROPER SEQUENCE AND APPLY PERMANENT COVERING AT THE EARLIEST POSSIBLE DATE, WITHIN 14 DAYS, AFTER REACHING FINAL GRADE. OUTSIDE THE REGULAR PLANTING SEASON, TEMPORARY SEED AND MULCH SHALL BE PLACED AS STATED HERE. HOWEVER, NO PAYMENT FOR TEMPORARY SEEDING AND MULCHING WILL BE MADE IF THE TIME OF APPLICATION IS WITHIN THE REGULAR PLANTING SEASON(S) STATED IN THE SPECIAL PROVISIONS. DURING THE REGULAR PLANTING SEASON(S), ONLY PERMANENT COVERING SHALL BE PAID.

THE QUANTITIES SHOWN INCLUDE THE ESTIMATED TEMPORARY SEEDING AND MULCHING, ITEM AR156533, THAT MAY BE PLACED OUTSIDE THE REGULAR PLANTING SEASON. TEMPORARY SEEDING AND MULCHING PLACED DURING THE REGULAR PLANTING SEASON IS INCIDENTAL TO THE CONTRACT.



PROPOSED SEED AND EROSION CONTROL MATERIALS 2' WIDE (TYP.) ON EITHER SIDE OF SIDEWALK UNLESS ADDITIONAL GRADING WORK INDICATES OTHERWISE

SEEDING AND EROSION CONTROL BLANKET IN GRADED AREAS.

CENTERLINE, AIRPORT ENTRANCE ROAD.

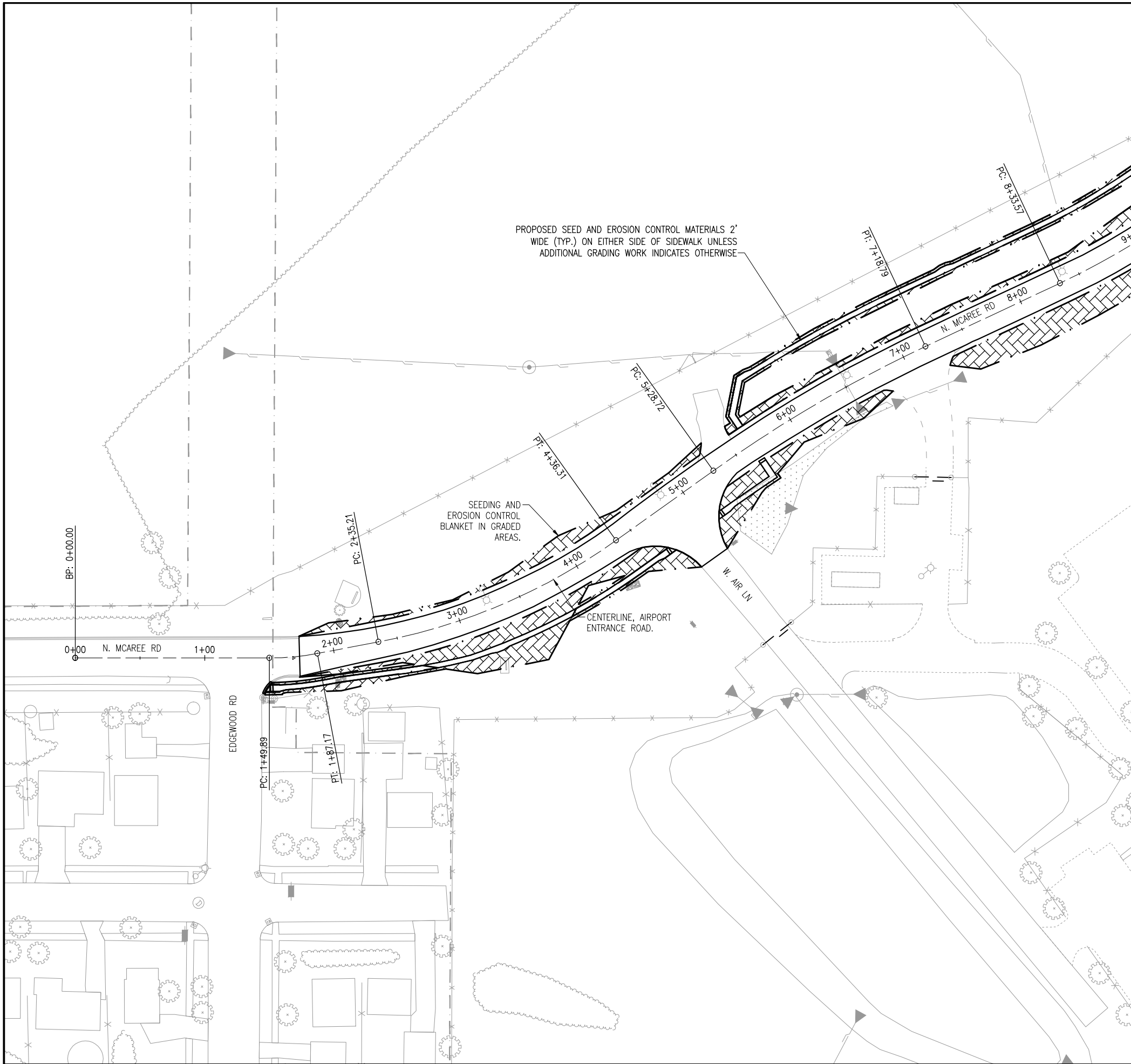

REHABILITATE AIRPORT ENTRANCE ROAD (BASE BID) WITH CONSTRUCT SIDEWALK (ADDITIVE ALTERNATES)

IDA No: UGN-4631

WA073

MARK	DATE	DESCRIPTION		
		DES	DRN	REV

ISSUE:
 PROJECT NO: 17A0077
 CAD FILE: 40-LANDSCAPING.DWG
 DESIGN BY: XXX XX/XX/XXXX
 DRAWN BY: XXX XX/XX/XXXX
 REVIEWED BY: KMS 10/17/18

SHEET TITLE

LANDSCAPING PLAN

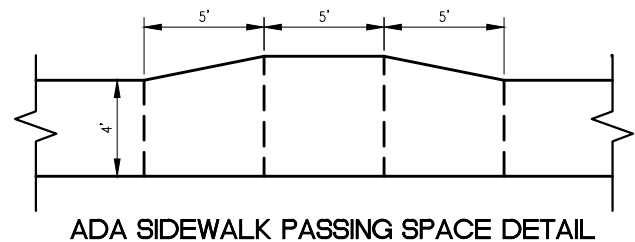

ADA SIDEWALK PASSING SPACE DETAIL

NOTE: MAXIMUM ALLOWABLE SEGMENT LENGTH WHERE SIDEWALK IS LESS THAN 5 FEET IS 200 FEET.

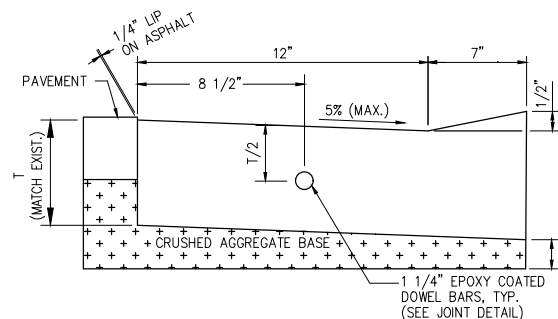

**SECTION
DEPRESSED CURB ADJACENT
TO CURB RAMP ACCESSIBLE
TO THE DISABLED**

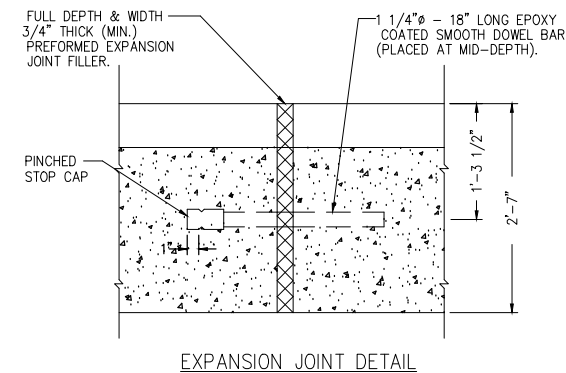

EXPANSION JOINT DETAIL

NOTES

- CONTRACTION JOINTS TO BE LOCATED AT NO GREATER THAN 12.5' ON CENTER. CONTRACTION JOINTS ARE TO BE EITHER 3/4" THICK PREFORMED JOINT FILLER, SAWED 2" DEEP AT 4 TO 24 HOURS OR FORMED WITH A 1/8" THICK STEEL TEMPLATE 2" DEEP.
- EXPANSION JOINTS TO BE LOCATED 5' FROM EACH SIDE OF AN INLET STRUCTURE AND AT 50' MAX SPACING.
- ALL EXPANSION AND SAWED CONTRACTION JOINTS SHALL BE SEALED WITH HOT-POURED SEALANT, ASTM D6690, TYPE II, COST INCIDENTAL TO CURB AND GUTTER.
- COST OF CRUSHED AGGREGATE BASE UNDER CURB AND GUTTER INCIDENTAL TO ITEM 754.

COMBINATION CONCRETE CURB AND GUTTER

(DOT STANDARD 606001 - MODIFIED)

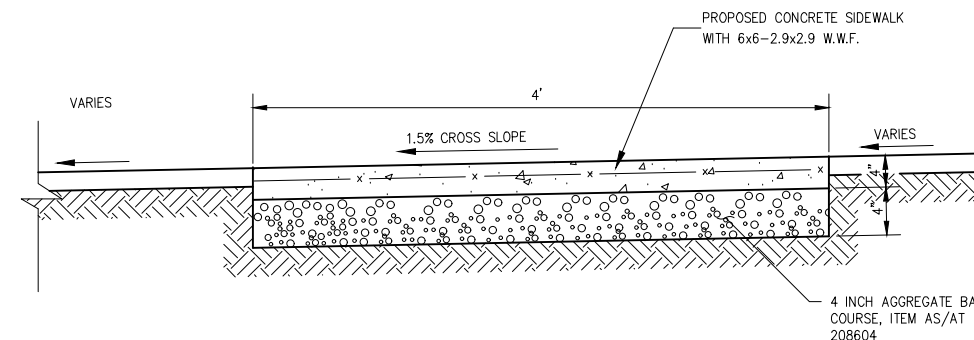

NOTES:

- 3/4" PREFORMED JOINT FILLER TO BE USED IN ALL LOCATIONS WHERE SIDEWALK IS ADJACENT TO EXISTING PAVEMENT.
- SIDEWALK WIDTH IS TO BE 5' NEAR CROSSWALKS AS SHOWN IN THE PLANS. JOINT GRID MAXIMUM AT THESE LOCATIONS IS 5'x5'.
- 5'x5' (MIN.) PASSING SPACES SHALL BE PROVIDED AT INTERVALS OF 200' MAXIMUM.
- SIDEWALK GRADES AND CROSS SLOPES ARE SUBJECT TO PROWAG REQUIREMENTS INCLUDING, BUT NOT LIMITED TO:
 - MAX. RUNNING SLOPE = 5.0%
 - MAX. CROSS SLOPE = 2.0%
 - LEVEL LANDING AREAS AND TURNING AREAS: 2% MAX. IN ANY DIRECTION
- JOINTS ARE TO BE SPACED EVENLY, MAX IS 4' GRID, WITH TRANSVERSE 3/4" PREFORMED EXPANSION JOINTS AT 24' MAX. INTERVALS.
- SEEDING AND EROSION CONTROL BLANKET TO EXTEND TO THE LIMITS OF CONSTRUCTION (A MINIMUM OF 2 FEET FROM THE EDGE OF SIDEWALK).

SIDEWALK CROSS SECTION DETAIL

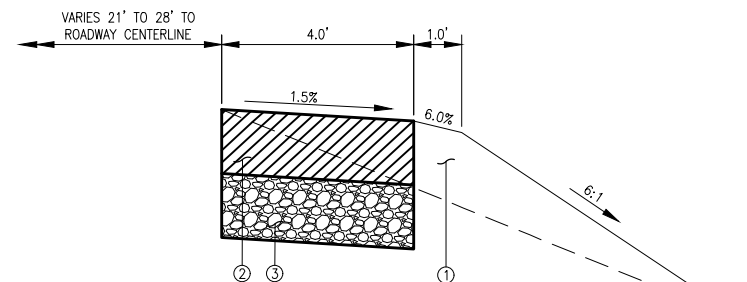

SIDEWALK

(STA 1+47.27 TO STA 5+64.50)

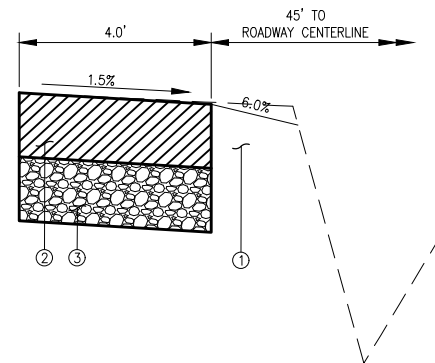

SIDEWALK

(STA 5+64.50 TO STA 10+00.00)

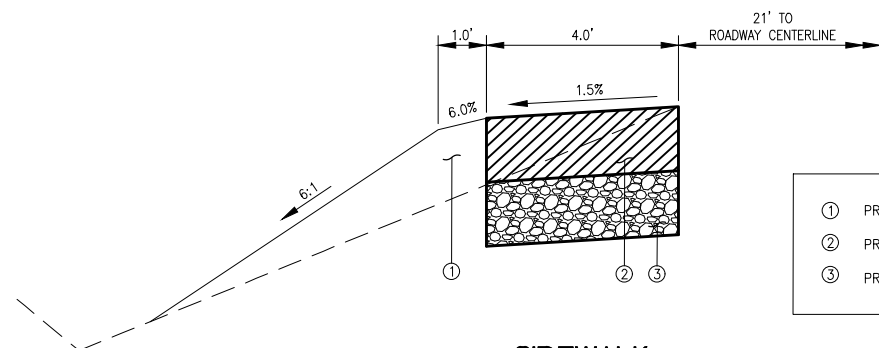

SIDEWALK

(STA 10+00.00 TO STA 16+30.00)

- ① PROPOSED TOPSOILING, ITEM AR905510
- ② PROPOSED 4" PCC SIDEWALK, ITEM AS/AT501604
- ③ PROPOSED 4" AGGREGATE BASE COURSE, ITEM AS/AT208604

REHABILITATE AIRPORT
ENTRANCE ROAD (BASE BID)
WITH CONSTRUCT SIDEWALK
(ADDITIVE ALTERNATES)

IDA No: UGN-4631

WA073

MARK	DATE	DESCRIPTION		
		DES	DRN	REV

ISSUE:

PROJECT NO: 17A0077
CAD FILE: 41-SIDEWALK DET.DWG
DESIGN BY: LDH
DRAWN BY: SCS
REVIEWED BY: KMS 10/17/18

SHEET TITLE

**SIDEWALK AND CURB
DETAILS**



REHABILITATE AIRPORT
ENTRANCE ROAD

IDA No: UGN-4631

WA073

MARK	DATE	DESCRIPTION		
		DES	DRN	REV

ISSUE:
PROJECT NO: 17A0077
CAD FILE: 42-HWYSTD-01.DWG
DESIGN BY: KMA
DRAWN BY: MWH
REVIEWED BY: KMA 10/17/18

SHEET TITLE

PERPENDICULAR
CURB RAMP
STANDARDS

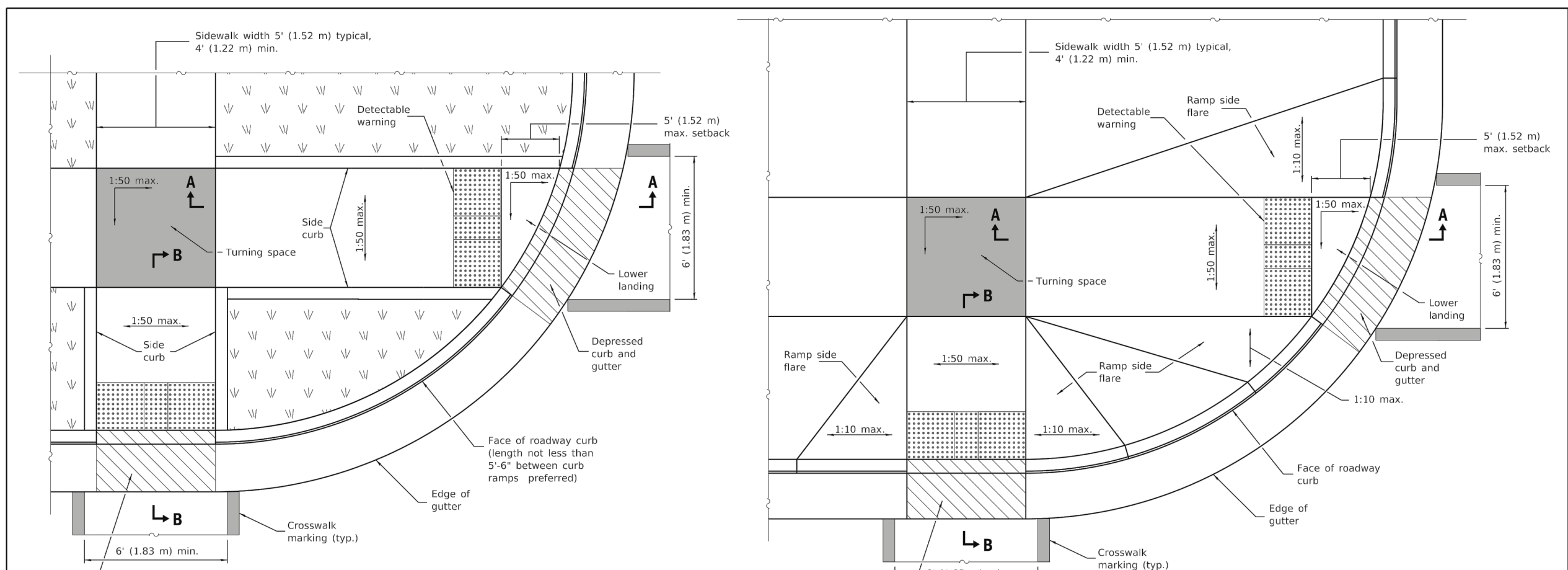

**RAMPS IN LANDSCAPED AREA
SETBACK ≤ 5'**

**RAMPS IN PAVED AREA
SETBACK ≤ 5'**

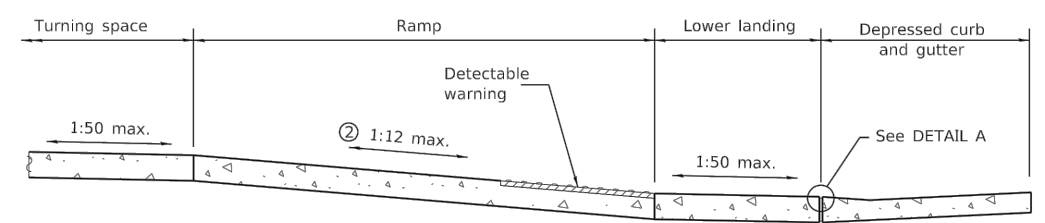

SECTION A-A

② The running slope of the curb ramp shall not require the ramp length to exceed 15' (4.5 m).

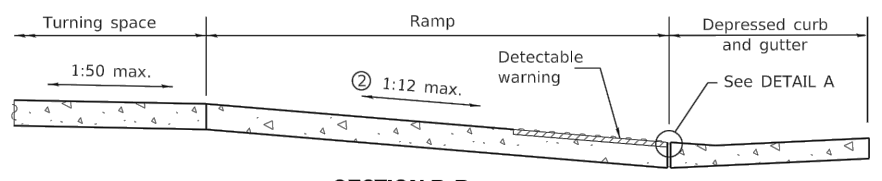

SECTION B-B

② The running slope of the curb ramp shall not require the ramp length to exceed 15' (4.5 m).

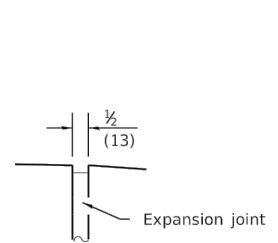

DETAIL A

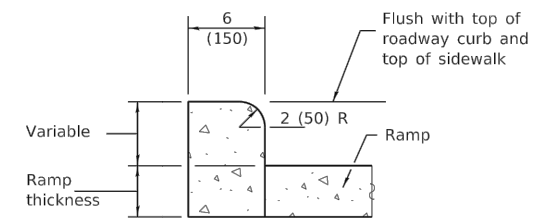

SIDE CURB DETAIL

See Sheet 2 for GENERAL NOTES.

DATE	REVISIONS
1-1-18	Omitted diagonal slope at turning spaces and lower landings.
1-1-17	Added 2' dimension to det. warnings for setbacks greater than 5'.

**PERPENDICULAR CURB RAMPS
FOR SIDEWALKS**
(Sheet 1 of 2)

STANDARD 424001-10

Illinois Department of Transportation

PASSED January 1, 2018
Michael Brand
ENGINEER OF POLICY AND PROCEDURES

APPROVED January 1, 2018
Walter M. Adams
ENGINEER OF DESIGN AND ENVIRONMENT

ISSUED 1-1-97

Hanson Professional Services Inc.
750 Warrenville Road
Lisle, IL 60532
phone: 630-990-3800
fax: 630-990-3801
Offices Nationwide
www.hanson-inc.com

Illinois Licensed
Professional Service Corporation
#184-001084



WAUKEGAN NATIONAL AIRPORT
WAUKEGAN PORT DISTRICT
2601 Plane Rest Drive
Waukegan, Illinois 60087
Telephone: 847.244.0055
Fax: 847.244.3813

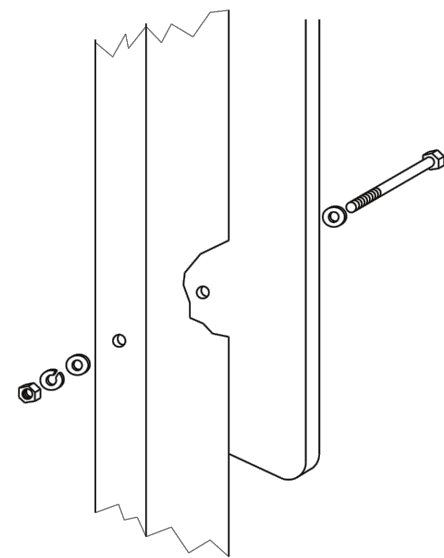

Sign panel 36 (900) wide or less

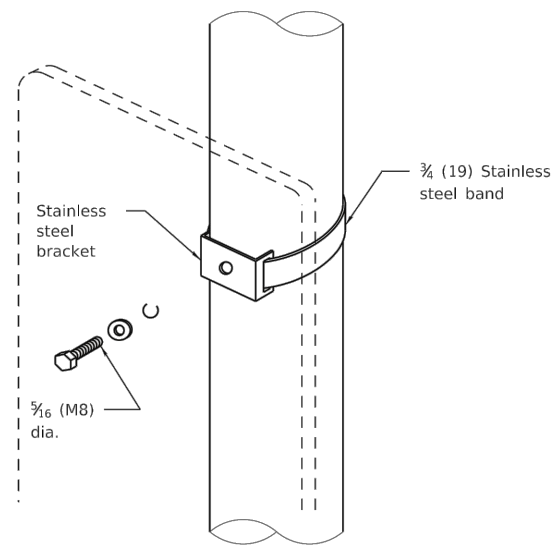

Sign panel 36 (900) wide or less

Section modulus (minimum)	Axis A	Axis B
Steel	0.050 in. ³ (819 mm ³)	0.105 in. ³ (1720 mm ³)
Aluminum	0.150 in. ³ (2458 mm ³)	0.315 in. ³ (5162 mm ³)

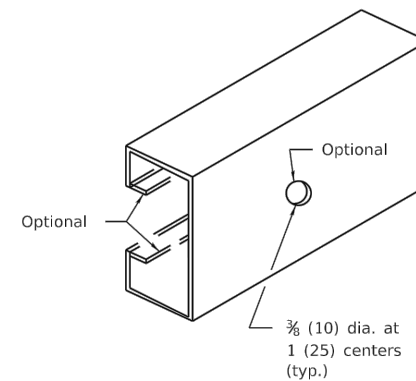
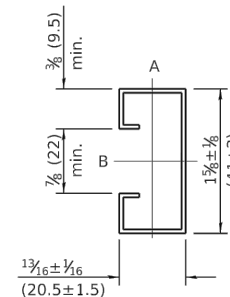

SUPPORTING CHANNEL DETAILS

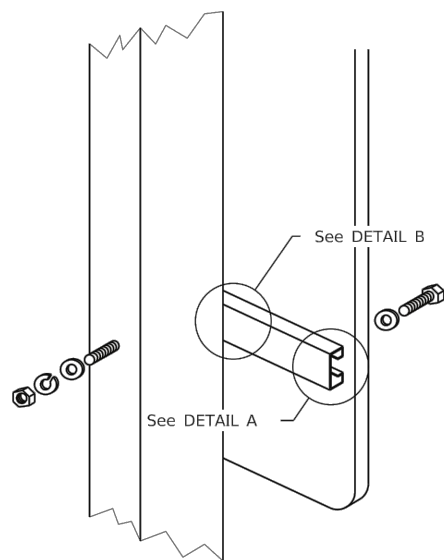

Sign panel over 36 (900) wide

WOOD OR TELESCOPING STEEL POSTS

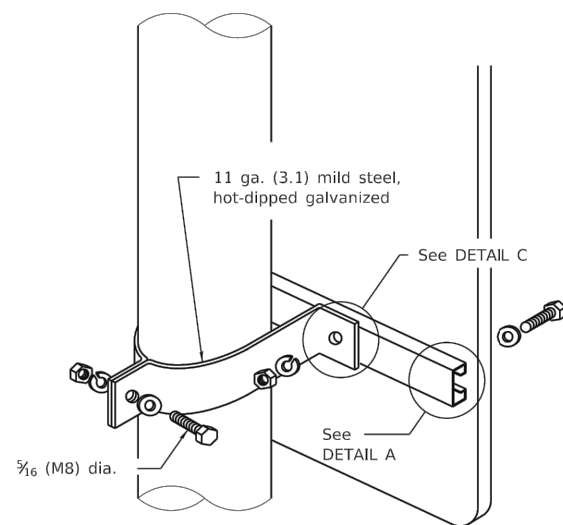

Sign panel over 36 (900) wide

LIGHT OR SIGNAL STANDARDS

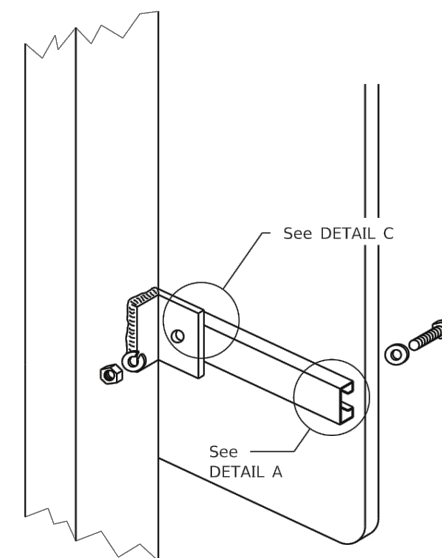

BREAKAWAY STEEL TUBING POSTS
(All sign panel sizes)

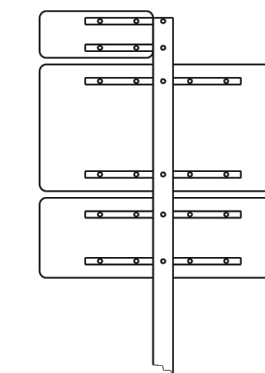

ROUTE MARKER ASSEMBLY

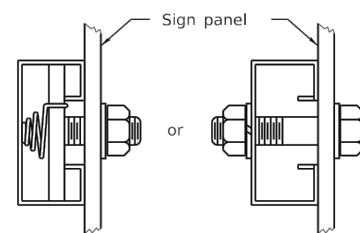

DETAIL A

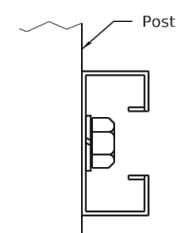

DETAIL B

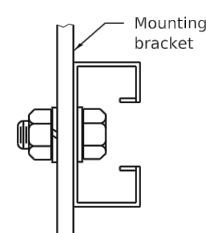

DETAIL C

All dimensions are in inches (millimeters) unless otherwise shown.

DATE	REVISIONS	SIGN PANEL MOUNTING DETAILS
1-1-09	Switched units to English (metric).	
1-1-97	Renum. Standard 2319-6.	
		STANDARD 720001-01

REHABILITATE AIRPORT ENTRANCE ROAD

IDA No: UGN-4631

WA073

MARK	DATE	DESCRIPTION		
		DES	DRN	REV

ISSUE:
PROJECT NO: 17A0077
CAD FILE: 43-HWYSTD-02.DWG
DESIGN BY: KMA
DRAWN BY: MWH
REVIEWED BY: KMA 10/17/18

SHEET TITLE

SIGN PANEL MOUNTING STANDARDS

Illinois Department of Transportation

PASSED January 1, 2009
ENGINEER OF OPERATIONS

APPROVED January 1, 2009
ENGINEER OF DESIGN AND ENVIRONMENT

ISSUED 1-1-97

Hanson Professional Services Inc.
750 Warrenville Road
Lisle, IL 60532
phone: 630-990-3800
fax: 630-990-3801
Offices Nationwide
www.hanson-inc.com

Illinois Licensed
Professional Service Corporation
#184-001084



WAUKEGAN NATIONAL AIRPORT
WAUKEGAN PORT DISTRICT
2601 Plane Rest Drive
Waukegan, Illinois 60087
Telephone: 847.244.0055
Fax: 847.244.3813

REHABILITATE AIRPORT
ENTRANCE ROAD

IDA No: UGN-4631

WA073

MARK	DATE	DESCRIPTION		
		DES	DRN	REV

ISSUE:
PROJECT NO: 17A0077
CAD FILE: 44-HWYSTD-02.DWG
DESIGN BY: KMA
DRAWN BY: MWH
REVIEWED BY: KMA 10/17/18

SHEET TITLE

SIGN PANEL
ERECTION
STANDARDS

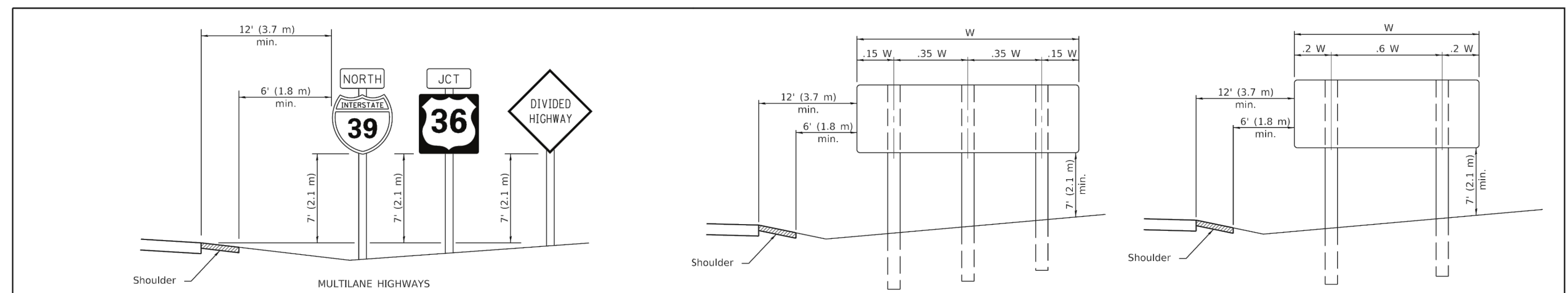

POST SPACING FOR NON-FREEWAY SIGN PANELS

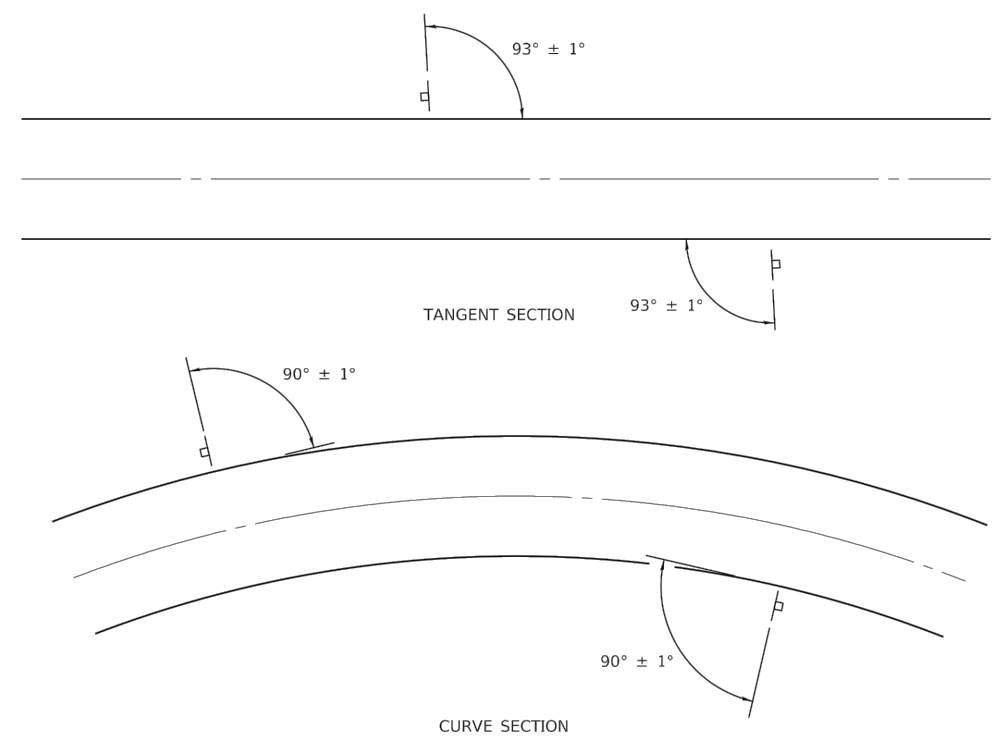

GROUND MOUNT SIGN POSITIONING

All dimensions are in inches (millimeters) unless otherwise shown.

DATE	REVISIONS	SIGN PANEL ERECTION DETAILS
1-1-14	Added shoulders and slopes. Changed sign distances from roadway and shoulder.	
1-1-12	Rev. sign elev. for multilane hwy's. Revised sign elev. and dist. to curb for rural loc.	STANDARD 720006-04

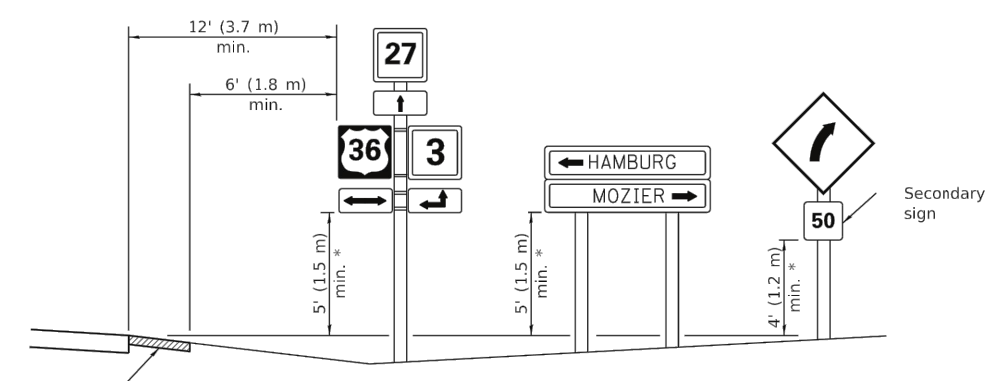

* In any area where parking is likely to occur or where there are obstructions to view or where signs are located over sidewalks, the height shall be at least 7' (2.1 m).

TWO LANE RURAL HIGHWAYS

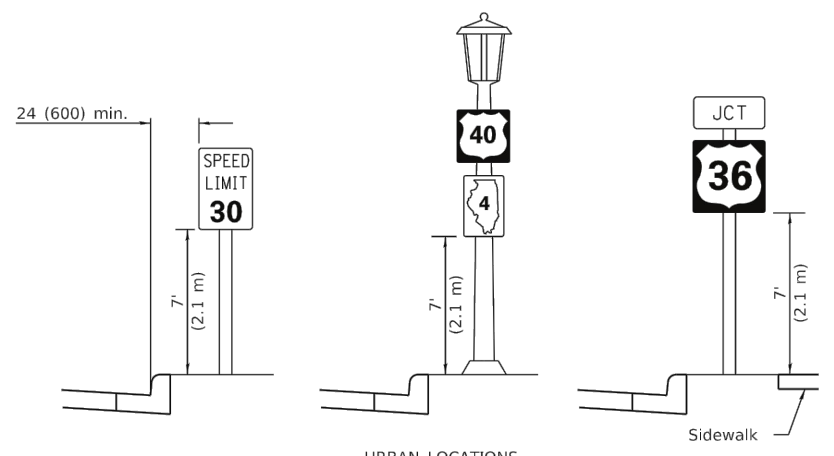

TYPICAL INSTALLATIONS

Signs in any area shall be erected to a uniform height above the edge of the pavement.

Illinois Department of Transportation

PASSED January 1, 2014
Justin Mann
 ENGINEER OF OPERATIONS

APPROVED January 1, 2014
[Signature]
 ENGINEER OF DESIGN AND ENVIRONMENT

ISSUED 1-1-97

Hanson Professional Services Inc.
750 Warrenville Road
Lisle, IL 60532
phone: 630-990-3800
fax: 630-990-3801
Offices Nationwide
www.hanson-inc.com

Illinois Licensed
Professional Service Corporation
#184-001084



WAUKEGAN NATIONAL AIRPORT
WAUKEGAN PORT DISTRICT
2601 Plane Rest Drive
Waukegan, Illinois 60087
Telephone: 847.244.0055
Fax: 847.244.3813

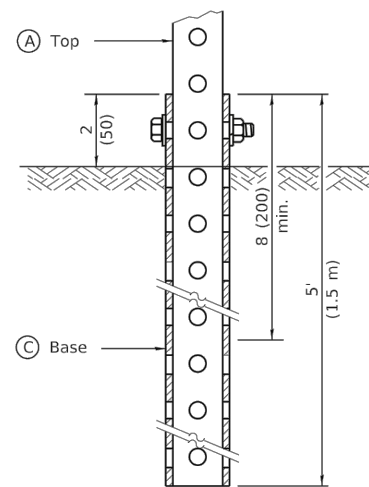

GROUND MOUNT DETAIL

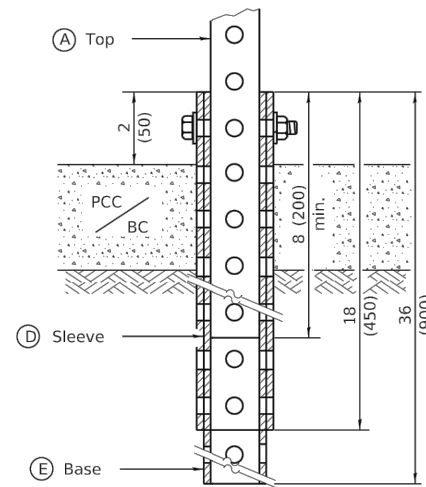

PAVEMENT MOUNT DETAIL

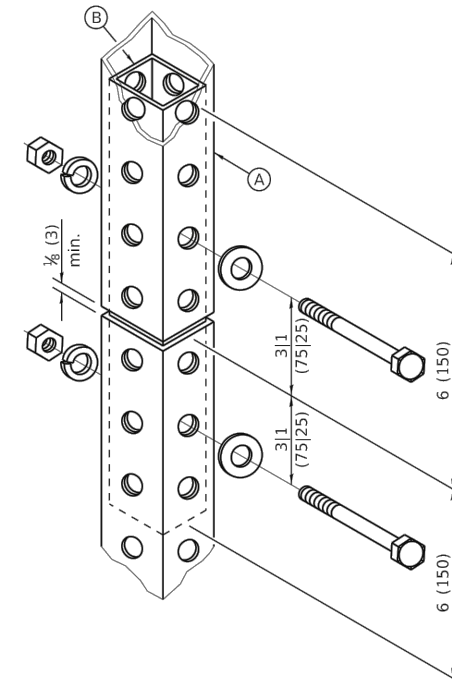

SPLICE DETAIL

(A)	2 x 2 x var. (51 x 51 var.)
(B)	1 3/4 x 1 3/4 x 12 (44 x 44 x 300)
(C)	2 1/4 x 2 1/4 x 60 (57 x 57 x 1500)
(D)	2 1/2 x 2 1/2 x 18 (64 x 64 x 450)
(E)	2 1/4 x 2 1/4 x 36 (57 x 57 x 900)

GENERAL NOTES

All bolts 3/8" (M10) hex head zinc or cadmium plated.

All dimensions are in inches (millimeters) unless otherwise shown.

DATE	REVISIONS	
1-1-09	Switched units to English (metric).	TELESCOPING STEEL SIGN SUPPORT
1-1-07	New Standard. Used to be part of Standard 720006.	
		STANDARD 728001-01

REHABILITATE AIRPORT ENTRANCE ROAD

IDA No: UGN-4631

WA073

MARK	DATE	DESCRIPTION		
		DES	DRN	REV

ISSUE:
PROJECT NO: 17A0077
CAD FILE: 45-HWYSTD-02.DWG
DESIGN BY: KMA
DRAWN BY: MWH
REVIEWED BY: KMA 10/17/18

SHEET TITLE

TELESCOPING STEEL SIGN SUPPORT STANDARDS

Illinois Department of Transportation

PASSED January 1, 2009
ENGINEER OF OPERATIONS

APPROVED January 1, 2009
ENGINEER OF DESIGN AND ENVIRONMENT

ISSUED 1-1-07