

21A

Letting January 18, 2019

Notice to Bidders, Specifications and Proposal



**Illinois Department
of Transportation**

Springfield, Illinois 62764

**Contract No. SH029
Schaumburg Regional Airport
Schaumburg, Illinois
Cook County
Illinois Project No. 06C-4649
SBG Project No. N/A**



NOTICE TO BIDDERS

- 1. TIME AND PLACE OF OPENING BIDS.** Electronic bids are to be submitted to the electronic bidding system (iCX-Integrated Contractors Exchange). All bids must be submitted to the iCX system prior to 10:00 a.m. on January 18, 2019, at which time the bids will be publicly opened from the iCX SecureVault.
- 2. DESCRIPTION OF WORK.** The proposed improvement is identified and advertised for bids in the Invitation for Bids as:

**Contract No. SH029
Schaumburg Regional Airport
Schaumburg, Illinois
Cook County
Illinois Project No. 06C-4649
SBG Project No. N/A**

Rehabilitate Terminal Entrance Road and Auto Parking Lot

For engineering information, please contact Doug Klonowski, P.E. of Crawford, Murphy & Tilly, Inc. at 630.907.7026.

3. INSTRUCTIONS TO BIDDERS.

- (a) This Notice, the invitation for bids, proposal and letter of award shall, together with all other documents in accordance with Article 10-18 of the Illinois Standard Specifications for Construction of Airports, become part of the contract. Bidders are cautioned to read and examine carefully all documents, to make all required inspections, and to inquire or seek explanation of the same prior to submission of a bid.
- (b) State law, and, if the work is to be paid wholly or in part with Federal-aid funds, Federal law requires the bidder to make various certifications as a part of the proposal and contract. By execution and submission of the proposal, the bidder makes the certification contained therein. A false or fraudulent certification shall, in addition to all other remedies provided by law, be a breach of contract and may result in termination of the contract.

- 4. AWARD CRITERIA AND REJECTION OF BIDS.** This contract will be awarded within 60 calendar days to the lowest responsive and responsible bidder considering conformity with the terms and conditions established by the Department in the rules, Invitation for Bids and contract documents. The issuance of plans and proposal forms for bidding based upon a prequalification rating shall not be the sole determinant of responsibility. The Department reserves the right to determine responsibility at the time of award, to reject any or all proposals, to readvertise the proposed improvement, and to waive technicalities.

- 5. PRE-BID CONFERENCE.** N/A

- 6. DISADVANTAGED BUSINESS POLICY.** The DBE goal for this contract is 4.0%.

- 7. SPECIFICATIONS AND DRAWINGS.** The work shall be done in accordance with the Illinois Standard Specifications for Construction of Airports, the Special Provisions dated November 16, 2018, and the Construction Plans dated November 16, 2018 as approved by the Illinois Department of Transportation, Division of Aeronautics.

- 8. BIDDING REQUIREMENTS AND BASIS OF AWARD.** When alternates are included in the proposal, the following shall apply:
- a. Additive Alternates
 - (1) Bidders must submit a bid for the Base Bid and for all Additive Alternates.
 - (2) Award of this contract will be made to the lowest responsible qualified bidder computed as follows:

The lowest aggregate amount of (i) the Base Bid plus (ii) any Additive Alternate(s) which the Department elects to award.

The Department may elect not to award any Additive Alternates. In that case, award will be to the lowest responsible qualified bidder of the Base Bid.
 - b. Optional Alternates
 - (1) Bidders must submit a bid for the Base Bid and for either Alternate A or Alternate B or for both Alternate A and Alternate B.
 - (2) Award of this contract will be made to the lowest responsible qualified bidder computed as follows:

The lower of the aggregate of either (i) the Base Bid plus Alternate A or (ii) the Base Bid plus Alternate B.
- 9. CONTRACT TIME.** The Contractor shall complete all work within the specified contract time. Any calendar day extension beyond the specified contract time must be fully justified, requested by the Contractor in writing, and approved by the Engineer, or be subject to liquidated damages.
- The contract time for this contract is 40 calendar days.
- 10. INDEPENDENT WEIGHT CHECKS.** The Department reserves the right to conduct random unannounced independent weight checks on any delivery for bituminous, aggregate or other pay item for which the method of measurement for payment is based on weight. The weight checks will be accomplished by selecting, at random, a loaded truck and obtaining a loaded and empty weight on an independent scale. In addition, the department may perform random weight checks by obtaining loaded and empty truck weights on portable scales operated by department personnel.
- 11. MATERIAL COST ADJUSTMENTS.** The Illinois Department of Transportation, Division of Aeronautics does not offer any material cost adjustment provisions.
- 12. GOOD FAITH COMPLIANCE.** The Illinois Department of Transportation has made a good faith effort to include all statements, requirements, and other language required by federal and state law and by various offices within federal and state governments whether that language is required by law or not. If anything of this nature has been left out or if additional language etc. is later required, the bidder/contractor shall cooperate fully with the Department to modify the contract or bid documents to correct the deficiency. If the change results in increased operational costs, the Department shall reimburse the contractor for such costs as it may find to be reasonable.

By Order of the
Illinois Department of Transportation

Randall S. Blankenhorn,
Secretary



Sponsor _____ Item No. _____

IL Proj. No. _____ SBG Pr. No. _____ Letting Date _____

KNOW ALL MEN BY THESE PRESENTS, That We _____

as PRINCIPAL, and _____

_____ as SURETY, are held jointly, severally and firmly bound unto the SPONSOR identified above, in the penal sum of 5 percent of the total bid price, or for the amount specified in Section 6, Proposal Guaranty of the Proposal Document, whichever is the lesser sum, well and truly to be paid unto said SPONSOR, for the payment of which we bind ourselves, our heirs, executors, administrators, successors and assigns.

THE CONDITION OF THE FOREGOING OBLIGATION IS SUCH, that whereas, the PRINCIPAL has submitted a bid proposal to the SPONSOR through its AGENT, the State of Illinois, Department of Transportation, Division of Aeronautics, for the improvement designated by the Transportation Bulletin Item Number and Letting Date indicated above.

NOW, THEREFORE, if the SPONSOR through its AGENT shall accept the bid proposal of the PRINCIPAL; and if the PRINCIPAL shall, and as specified in the bidding and contract documents, submit a DBE Utilization Plan that is accepted and approved by the AGENT; and if, after the award by AGENT on behalf of SPONSOR, the PRINCIPAL shall enter into a contract in accordance with the terms of the bidding and contract documents, including evidence of the required insurance coverages and providing such bond as specified with good and sufficient surety for the faithful performance of such contract and for the prompt payment of labor and material furnished in the prosecution thereof; or if, in the event of the failure of the PRINCIPAL to make the required DBE submission or to enter into such contract and to give the specified bond, the PRINCIPAL pays to the SPONSOR the difference not to exceed the penalty hereof between the amount specified in the bid proposal and such larger amount for which the SPONSOR may contract with another party to perform the work covered by said bid proposal, then this obligation shall be null and void, otherwise, it shall remain in full force and effect.

IN THE EVENT the SPONSOR acting through its AGENT determines the PRINCIPAL has failed to comply with any requirement as set forth in the preceding paragraph, then SURETY shall pay the penal sum to the SPONSOR within fifteen (15) days of written demand therefor. If SURETY does not make full payment within such period of time, the AGENT may bring an action to collect the amount owed. SURETY is liable to the SPONSOR and to the AGENT for all its expenses, including attorney's fees, incurred in any litigation in which SPONSOR or AGENT prevail either in whole or in part.

In TESTIMONY WHEREOF, the said PRINCIPAL and the said SURETY have caused this instrument to be signed by their respective officers _____ day of _____ A.D., _____ .

PRINCIPAL _____ **SURETY** _____
(Company Name) (Company Name)

By _____ By: _____
(Signature & Title) (Signature of Attorney-in-Fact)

Notary Certification for Principal and Surety

STATE OF ILLINOIS,
County of _____

I, _____, a Notary Public in and for said County, do hereby certify that _____ and _____
(Insert names of individuals signing on behalf of PRINCIPAL & SURETY)

who are each personally known to me to be the same persons whose names are subscribed to the foregoing instrument on behalf of PRINCIPAL and SURETY, appeared before me this day in person and acknowledged respectively, that they signed and delivered said instrument as their free and voluntary act for the uses and purposes therein set forth.

Given under my hand and notarial seal this _____ day of _____ A.D. _____

My commission expires _____
Notary Public

In lieu of completing the above section of the Proposal Bid Form, the Principal may file an Electronic Bid Bond. By signing the proposal and marking the check box next to the Signature and Title line below, the Principal is ensuring the identified electronic bid bond has been executed and the Principal and Surety are firmly bound unto the SPONSOR through its AGENT under the conditions of the bid bond as shown above.

Electronic Bid Bond ID# _____ Company / Bidder Name _____ Signature and Title _____

State of Illinois
Department of Transportation

SPECIAL PROVISION
FOR
EEO

Effective: July 21, 1978
Revised: November 18, 1980

The requirements of the following provisions written for federally-assisted construction contracts, including all goals and timetables and affirmative action steps, shall also apply to all State-funded construction contracts awarded by the Illinois Department of Transportation.

Notice of Requirement for Affirmative Action to Ensure
Equal Employment Opportunity (Executive Order 11246)

1. The offeror's or bidder's attention is called to the "Equal Opportunity Clause" and the "Standard Federal Equal Employment Opportunity Construction Contract Specifications" set forth herein.
2. The goals and timetables for minority and female participation, expressed in percentage terms for the Contractor's aggregate workforce in each trade on all construction work in the covered area, are as follows:

APPENDIX A

The following goal for female utilization in each construction craft and trade shall apply to all Contractors holding Federal and federally assisted construction contracts and subcontracts in excess of \$10,000. The goal is applicable to the Contractor's total on-site construction workforce, regardless of whether or not part of that workforce is performing work on a federal, federally assisted or nonfederally related construction contract or subcontract.

Area Covered (Statewide)

Goals for Women apply nationwide.

GOAL	Goal (percent)
Female Utilization	6.9

APPENDIX B

Until further notice, the following goals for minority utilization in each construction craft and trade shall apply to all Contractors holding federal and federally-assisted construction contracts and subcontracts in excess of \$10,000 to be performed in the respective geographical areas. The goals are applicable to the Contractor's total on-site construction workforce, regardless of whether or not part of that workforce is performing work on a federal, federally-assisted or nonfederally related construction contract or subcontract.

<u>Economic Area</u>	Goal (percent)
056 Paducah, KY: Non-SMSA Counties - IL - Hardin, Massac, Pope KY - Ballard, Caldwell, Calloway, Carlisle, Crittenden, Fulton, Graves, Hickman, Livingston, Lyon, McCracken, Marshall	5.2
080 Evansville, IN: Non-SMSA Counties - IL - Edwards, Gallatin, Hamilton, Lawrence, Saline, Wabash, White IN - Dubois, Knox, Perry, Pike, Spencer KY - Hancock, Hopkins, McLean, Mublenberg, Ohio, Union, Webster	3.5
081 Terre Haute, IN: Non-SMSA Counties - IL - Clark, Crawford IN - Parke	2.5

083	Chicago, IL: SMSA Counties: 1600 Chicago, IL -	19.6
	IL - Cook, DuPage, Kane, Lake, McHenry, Will 3740 Kankakee, IL -	9.1
	IL - Kankakee Non-SMSA Counties	18.4
	IL - Bureau, DeKalb, Grundy, Iroquois, Kendall, LaSalle, Livingston, Putnam	
	IN - Jasper, Laporte, Newton, Pulaski, Starke	
084	Champaign - Urbana, IL: SMSA Counties: 1400 Champaign - Urbana - Rantoul, IL -	7.8
	IL - Champaign Non-SMSA Counties -	4.8
	IL - Coles, Cumberland, Douglas, Edgar, Ford, Piatt, Vermilion	
085	Springfield - Decatur, IL: SMSA Counties: 2040 Decatur, IL -	7.6
	IL - Macon 7880 Springfield, IL -	4.5
	IL - Menard, Sangamon Non-SMSA Counties	4.0
	IL - Cass, Christian, Dewitt, Logan, Morgan, Moultrie, Scott, Shelby	
086	Quincy, IL: Non-SMSA Counties	3.1
	IL - Adams, Brown, Pike	
	MO - Lewis, Marion, Pike, Ralls	
087	Peoria, IL: SMSA Counties: 1040 Bloomington - Normal, IL -	2.5
	IL - McLean 6120 Peoria, IL -	4.4
	IL - Peoria, Tazewell, Woodford Non-SMSA Counties -	3.3
	IL - Fulton, Knox, McDonough, Marshall, Mason, Schuyler, Stark, Warren	
088	Rockford, IL: SMSA Counties: 6880 Rockford, IL -	6.3
	IL - Boone, Winnebago Non-SMSA Counties -	4.6
	IL - Lee, Ogle, Stephenson	
098	Dubuque, IA: Non-SMSA Counties -	0.5
	IL - JoDaviess	
	IA - Atlamakee, Clayton, Delaware, Jackson, Winnesheik	
	WI - Crawford, Grant, Lafayette	
099	Davenport, Rock Island, Moline, IA - IL: SMSA Counties: 1960 Davenport, Rock Island, Moline, IA - IL -	4.6
	IL - Henry, Rock Island IA - Scott Non-SMSA Counties -	3.4
	IL - Carroll, Hancock, Henderson, Mercer, Whiteside IA - Clinton, DesMoines, Henry, Lee, Louisa, Muscatine MO - Clark	

107	St. Louis, MO:	
	SMSA Counties:	
	7040 St. Louis, MO - IL -	14.7
	IL - Clinton, Madison, Monroe, St. Clair	
	MO - Franklin, Jefferson, St. Charles,	
	St. Louis, St. Louis City	
	Non-SMSA Counties -	11.4
	IL - Alexander, Bond, Calhoun, Clay,	
	Effingham, Fayette, Franklin, Greene,	
	Jackson, Jasper, Jefferson, Jersey,	
	Johnson, Macoupin, Marion, Montgomery,	
	Perry, Pulaski, Randolph, Richland,	
	Union, Washington, Wayne, Williamson	
	MO - Bollinger, Butler, Cape Girardeau,	
	Carter, Crawford, Dent, Gasconade,	
	Iron, Lincoln, Madison, Maries,	
	Mississippi, Montgomery, Perry,	
	Phelps, Reynolds, Ripley, St. Francois,	
	St. Genevieve, Scott, Stoddard, Warren,	
	Washington, Wayne	

These goals are applicable to all the Contractor's construction work (whether or not it is federal or federally assisted) performed in the covered area. If the Contractor performs construction work in a geographical area located outside of the covered area, it shall apply the goals established for such geographical area where the work is actually performed. With regard to this second area, the Contractor also is subject to the goals for both its federally involved and nonfederally involved construction.

The Contractor's compliance with Executive Order 11246 and the regulations in 41 CFR Part 60-4 shall be based on its implementation of the Equal Opportunity Clause, specific affirmative action obligations required by the provisions and specifications set forth in its federally assisted contracts, and its efforts to meet the goals established for the geographical area where the contract resulting from this solicitation is to be performed. The hours of minority and female employment and training must be substantially uniform throughout the length of the contract, and in each trade, and the Contractor shall make a good faith effort to employ minorities and women evenly on each of its projects. The transfer of minority or female employees or trainees from Contractor to Contractor or from project to project for the sole purpose of meeting the Contractor's goals shall be a violation of the contract, the Executive Order 11246 and the regulations in 41 CFR Part 60-4. Compliance with the goals will be measured against the total work hours performed.

3. The Illinois Department of Transportation will provide written notification to the Director of the Office of Federal Contract Compliance Programs within ten working days of award of any construction contract and/or subcontract in excess of \$10,000 at any tier for construction work under the contract resulting from this solicitation. This notification will list the name, address and telephone number of the subcontractor; employer identification number; estimated dollar amount of the subcontract; estimated starting and completion dates of the subcontract; and the geographical area in which the contract is to be performed.
4. As used in this Notice, and in the contract resulting from this solicitation, the "covered area" is the entire State of Illinois for the goal set forth in APPENDIX A and the county or counties in which the work is located for the goals set forth in APPENDIX B.

STANDARD FEDERAL EQUAL EMPLOYMENT
OPPORTUNITY CONSTRUCTION CONTRACT
SPECIFICATIONS (EXECUTIVE ORDER 11246)

1. As used in these specifications:
 - (a) "Covered area" means the geographical area described in the solicitation from which this contract resulted;
 - (b) "Director" means Director, Office of Federal Contract Compliance Programs, United States Department of Labor, or any person to whom the Director delegates authority;
 - (c) "Employer identification number" means the Federal Social Security number used on the Employer's Quarterly Federal Tax Return, U.S. Treasury Department Form 941;
 - (d) "Minority" includes:
 - (i) Black (all persons having origins in any of the Black African racial groups not of Hispanic origin);
 - (ii) Hispanic (all persons of Mexican, Puerto Rican, Cuban, Central or South American or other Spanish Culture or origin, regardless of race);
 - (iii) Asian and Pacific Islander (all persons having origins in any of the original peoples of the Far East, Southeast Asia, the Indian Subcontinent, or the Pacific Islands); and
 - (iv) American Indian or Alaskan Native (all persons having origins in any of the original peoples of North America and maintaining identifiable tribal affiliations through membership and participation or community identification).
2. Whenever the Contractor, or any Subcontractor at any tier, subcontracts a portion of the work involving any construction trade, it shall physically include in each subcontract in excess of \$10,000. the provisions of these specifications and the Notice which contains the applicable goals for minority and female participation and which is set forth in the solicitations from which this contract resulted.
3. If the Contractor is participating (pursuant to 41 CFR 60-4.5) in a Hometown Plan approved by the U.S. Department of Labor in the covered area either individually or through an association, its affirmative action obligations on all work in the plan area (including goals and timetables) shall be in accordance with that Plan for those trades which have unions participating in the Plan. Contractors must be able to demonstrate their participation in and compliance with the provisions of any such Hometown Plan. Each Contractor or Subcontractor participating in an approved Plan is individually required to comply with its obligations under the EEO clause, and to make a good faith effort to achieve each goal under the Plan in each trade in which it has employees. The overall good faith performance by other Contractors or Subcontractors toward a goal in an approved Plan does not excuse any covered Contractor's or Subcontractor's failure to take good faith efforts to achieve the Plan goals and timetables.

4. The Contractor shall implement the specific affirmative action standards provided in paragraphs 7a through p of these specifications. The goals set forth in the solicitation from which this contract resulted are expressed as percentages of the total hours of employment and training of minority and female utilization the Contractor should reasonably be able to achieve in each construction trade in which it has employees in the covered area. Covered Construction Contractors performing construction work in geographical areas where they do not have a Federal or federally assisted construction contract shall apply the minority and female goals established for the geographical area where the work is being performed. Goals are published periodically in the Federal Register in notice form, and such notices may be obtained from any Office of Federal Contract Compliance Programs office or from Federal procurement contracting officers. The Contractor is expected to make substantially uniform progress toward its goals in each craft during the period specified.
5. Neither the provisions of any collective bargaining agreement, nor the failure by a union with whom the Contractor has a collective bargaining agreement, to refer either minorities or women shall excuse the Contractor's obligations under these specifications, Executive Order 11246, or the regulations promulgated pursuant thereto.
6. In order for the nonworking training hours of apprentices and trainees to be counted in meeting the goals, such apprentices and trainees must be employed by the Contractor during the training period, and the Contractor must have made a commitment to employ the apprentices and trainees at the completion of their training, subject to the availability of employment opportunities. Trainees must be trained pursuant to training programs approved by the U.S. Department of Labor.
7. The Contractor shall take specific affirmative actions to ensure equal employment opportunity. The evaluation of the Contractor's compliance with these specifications shall be based upon its effort to achieve maximum results from its actions. The Contractor shall document these efforts fully, and shall implement affirmative action steps at least as extensive as the following:
 - (a) Ensure and maintain a working environment free of harassment, intimidation, and coercion at all sites, and in all facilities at which the Contractor's employees are assigned to work. The Contractor, where possible, will assign two or more women to each construction project. The Contractor shall specifically ensure that all foremen, superintendents, and other on-site supervisory personnel are aware of and carry out the Contractor's obligation to maintain such a working environment, with specific attention to minority or female individuals working as such sites or in such facilities.
 - (b) Establish and maintain a current list of minority and female recruitment sources, provide written notification to minority and female recruitment sources and to community organizations when the Contractor or its unions have employment opportunities available, and maintain a record of the organizations' responses.
 - (c) Maintain a current file of the names, addresses and telephone numbers of each minority and female off-the-street applicant and minority or female referral from a union, a recruitment source or community organization and of what action was taken with respect to each such individual. If such individual was sent to the union hiring hall for referral and was not referred back to the Contractor by the union or, if referred, not employed by the Contractor, this shall be documented in the file with the reason therefor, along with whatever additional actions the Contractors may have taken.
 - (d) Provide immediate written notification to the Director when the union or unions with which the Contractor has a collective bargaining agreement has not referred to the Contractor a minority person or woman sent by the Contractor, or when the Contractor has other information that the union referral process has impeded the Contractor's efforts to meet its obligations.
 - (e) Develop on-the-job training opportunities and/or participate in training programs for the area which expressly include minorities and women, including upgrading programs and apprenticeship and trainee programs relevant to the Contractor's employment needs, especially those programs funded or approved by the Department of Labor. The Contractor shall provide notice of these programs to the sources compiled under 7b above.
 - (f) Disseminate the Contractor's EEO policy by providing notice of the policy to unions and training programs and requesting their cooperation in assisting the Contractor in meeting its EEO obligations; by including it in any policy manual and collective bargaining agreements; by publicizing it in the company newspaper, annual report, etc.; by specific review of the policy with all management personnel and with all minority and female employees at least once a year; and by posting the company EEO policy on bulletin boards accessible to all employees at each location where construction work is performed.
 - (g) Review, at least annually, the company's EEO policy and affirmative action obligations under these specifications with all employees having any responsibility for hiring, assignment, layoff, termination or other employment decisions including specific review of these items with onsite supervisory personnel such as Superintendents, General Foreman, etc., prior to the initiation of construction work at any job site. A written record shall be made and maintained identifying the time and place of these meetings, persons attending, subject matter discussed, and disposition of the subject matter.
 - (h) Disseminate the Contractor's EEO policy externally by including it in any advertising in the news media, specifically including minority and female news media, and providing written notification to and discussing the Contractor's EEO policy with other Contractors and Subcontractors with whom the Contractor does or anticipates doing business.
 - (i) Direct its recruitment efforts, both oral and written, to minority, female and community organizations, to schools with minority and female students and to minority and female recruitment and training organizations serving the Contractor's recruitment area and employment needs. Not later than one month prior to the date for the acceptance of applications for apprenticeship or other training by any recruitment source, the Contractor shall send written notification to organizations such as the above, describing the openings, screening procedures, and tests to be used in the selection process.
 - (j) Encourage present minority and female employees to recruit other minority persons and women and, where reasonable, provide after school, summer and vacation employment to minority and female youth both on the site and in other areas of a Contractor's workforce.
 - (k) Validate all tests and other selection requirements where there is an obligation to do so under 41 CFR Part 60-3.

- (l) Conduct, at least annually, an inventory and evaluation at least of all minority and female personnel for promotional opportunities and encourage these employees to seek or to prepare for, through appropriate training, etc., such opportunities.
 - (m) Ensure that seniority practices, job classifications, work assignments and other personnel practices, do not have a discriminatory effect by continually monitoring all personnel and employment related activities to ensure that the EEO policy and the Contractor's obligations under these specifications are being carried out.
 - (n) Ensure that all facilities and company activities are nonsegregated except that separate or single-user toilet and necessary changing facilities shall be provided to assure privacy between the sexes.
 - (o) Document and maintain a record of all solicitations of offers for subcontracts from minority and female construction Contractors and suppliers, including circulation of solicitations to minority and female Contractor associations and other business associations.
 - (p) Conduct a review, at least annually, of all supervisors' adherence to and performance under the Contractor's EEO policies and affirmative action obligations.
8. Contractors are encouraged to participate in voluntary associations which assist in fulfilling one or more of their affirmative action obligations (7a through p). The efforts of a Contractor association, joint Contractor-union, Contractor-community, or other similar group of which the Contractor is a member and participant, may be asserted as fulfilling any one or more of its obligations under 7a through p of these Specifications provided that the Contractor actively participates in the group, makes every effort to assure that the group has a positive impact on the employment of minorities and women in the industry, ensures that the concrete benefits of the program are reflected in the Contractor's minority and female workforce participation makes a good faith effort to meet its individual goals and timetables, and can provide access to documentation which demonstrates the effectiveness of actions taken on behalf of the Contractor. The obligation to comply, however, is the Contractor's and failure of such a group to fulfill an obligation shall not be a defense for the Contractor's noncompliance.
 9. A single goal for minorities and a separate single goal for women have been established. The Contractor, however, is required to provide equal employment opportunity and to take affirmative action for all minority groups, both male and female, and all women, both minority and non-minority. Consequently, the Contractor may be in violation of the Executive Order if a particular group is employed in a substantially disparate manner (for example, even though the Contractor has achieved its goals for women generally, the Contractor may be in violation of the Executive Order if a specified minority group of women is underutilized).
 10. The Contractor shall not use the goals and timetables or affirmative action standards to discriminate against any person because of race, color, religion, sex, or national origin.
 11. The Contractor shall not enter into any Subcontract with any person or firm debarred from Government contracts pursuant to Executive Order 11246.
 12. The Contractor shall carry out such sanctions and penalties for violation of these specifications and of the Equal Opportunity Clause, including suspension, termination and cancellation of existing subcontracts as may be imposed or ordered pursuant to Executive Order 11246, as amended, and its implementing regulations, by the Office of Federal Contract Compliance Programs. Any Contractor who fails to carry out such sanctions and penalties shall be in violation of these specifications and Executive Order 11246, as amended.
 13. The Contractor, in fulfilling its obligations under these specifications, shall implement specific affirmative action steps, at least as extensive as those standards prescribed in paragraph 7 of these specifications, so as to achieve maximum results from its efforts to ensure equal opportunity. If the Contractor fails to comply with the requirements of the Executive Order, the implementing regulations, or these specifications, the Director shall proceed in accordance with 41 CFR 60-4.8.
 14. The Contractor shall designate a responsible official to monitor all employment related activity to ensure that the company EEO policy is being carried out, to submit reports relating to the provisions hereof as may be required by the Government and to keep records. Records shall at least include for each employee the name, address, telephone numbers, construction trade, union affiliation if any, employee identification number when assigned, social security number, race, sex, status (e.g., mechanic, apprentice, trainee, helper, or laborer), dates of changes in status, hours worked per week in the indicated trade, rate of pay, and locations at which the work was performed. Records shall be maintained in an easily understandable and retrievable form; however, to the degree that existing records satisfy his requirement, Contractors shall not be required to maintain separate records.
 15. Nothing herein provided shall be construed as a limitation upon the application of other laws which establish different standards of compliance or upon the application of requirements for the hiring of local or other area residents (e.g., those under the Public Works Employment Act of 1977 and the Community Development Block Grant Program).

State of Illinois
Department of Transportation

SPECIAL PROVISION
FOR
SPECIFIC EQUAL EMPLOYMENT OPPORTUNITY RESPONSIBILITIES
NONFEDERAL-AID CONTRACTS

Effective: March 20, 1969
Revised: January 1, 1994

1. General

- a. The requirements set forth herein shall constitute the specific affirmative action requirements under this contract and supplement the non-discrimination requirements contained elsewhere in this proposal.
- b. The Contractor shall work with the Illinois Department of Transportation (IDOT) in carrying out Equal Employment Opportunity (EEO) obligations and in reviews of activities under the contract.
- c. The Contractor, and all subcontractors holding subcontracts (not including material suppliers) of \$10,000 or more, shall comply with the following minimum specific requirement activities of EEO. The Contractor shall include these requirements in every subcontract of \$10,000 or more with such modification of language as is necessary to make them binding on the subcontractor.

2. Equal Employment Opportunity Policy

The Contractor shall accept as operating policy the following statement which is designed to further the provision of EEO to all persons, and to promote the full realization of equal employment opportunity through a positive continuing program: "It is the policy of this Company to ensure that applicants are employed, and that employees are treated during employment, without regard to their race, religion, sex, color, national origin, age, or disability. Such action shall include: employment, upgrading, demotion, or transfer; recruitment or recruitment advertising; layoff or termination; rates of pay or other forms of compensation; and selection for training, including apprenticeship, pre-apprenticeship, and/or on-the-job training."

3. Equal Employment Opportunity Officer

The Contractor shall designate and make known to IDOT contracting officers an EEO Officer who will have the responsibility for and must be capable of effectively administering and promoting an active Contractor program of EEO and who must be assigned adequate authority and responsibility to do so.

4. Dissemination of Policy

- a. All members of the Contractor's staff who are authorized to hire, supervise, promote, and discharge employees, or who recommend such action, or who are substantially involved in such action, will be made fully cognizant of, and will implement, the Contractor's EEO policy and contractual responsibilities to provide EEO in each grade and classification of employment. To ensure that the above agreement will be met, the following actions will be taken as a minimum:
 - (1) Periodic meetings of supervisory and personnel office employees will be conducted before the start of work and then not less often than once every six months, at which time the Contractor's EEO policy and its implementation will be reviewed and explained. The meetings will be conducted by the EEO Officer.
 - (2) All new supervisory or personnel office employees will be given a thorough indoctrination by the EEO Officer, covering all major aspects of the Contractor's EEO obligations within thirty days following their reporting for duty with the Contractor.
 - (3) All personnel who are engaged in direct recruitment for the project will be instructed by the EEO Officer in the Contractor's procedures for locating and hiring minority and female employees.
- b. In order to make the Contractor's EEO policy known to all employees, prospective employees, and potential sources of employees, i.e., schools, employment agencies, labor unions (where appropriate), college placement officers, etc., the Contractor shall take the following actions:
 - (1) Notices and posters setting forth the Contractor's EEO policy will be placed in areas readily accessible to employees, applicants for employment and potential employees.
 - (2) The Contractor's EEO policy and the procedures to implement such policy shall be brought to the attention of employees by means of meetings, employee handbooks, or other appropriate means.

5. Recruitment

- a. When advertising for employees, the Contractor shall include in all advertisements for employees the notation: "An Equal Opportunity Employer". All such advertisements shall be published in newspapers, or other publications, having a large circulation among minority groups in the area from which the project work force would normally be derived.
- b. The Contractor shall, unless precluded by a valid bargaining agreement, conduct systematic and direct recruitment through public and private employee referral sources likely to yield qualified minority and female applicants, including, but not limited to, State employment

agencies, schools, colleges and minority and female organizations. To meet this requirement, the Contractor shall, identify sources of potential minority and female employees, and establish with such identified sources procedures whereby minority and female applicants may be referred to the Contractor for employment consideration. In the event the Contractor has a valid bargaining agreement providing for exclusive hiring hall referrals, he/she is expected to observe the provisions of that agreement to the extent that the system permits the Contractor's compliance with EEO contract provisions.

- c. The Contractor shall encourage present employees to refer minority and female applicants for employment by posting appropriate notices or bulletins in areas accessible to all such employees. In addition, information and procedures with regard to referring minority and female applicants shall be discussed with employees.

6. Personnel Actions

Wages, working conditions, and employee benefits shall be established and administered, and personnel actions of every type, including hiring, upgrading, promotion, transfer, demotion, layoff, and termination, will be taken without regard to race, color, religion, sex, national origin, age, or disability. The following procedures shall be followed:

- a. The Contractor shall conduct periodic inspections of project sites to insure that working conditions and employee facilities do not indicate discriminatory treatment of project site personnel.
- b. The Contractor shall periodically evaluate the spread of wages paid within each classification to determine any evidence of discriminatory wage practices.
- c. The Contractor shall periodically review selected personnel actions in depth to determine whether there is evidence of discrimination. Where evidence is found, the Contractor shall promptly take corrective action. If the review indicates that the discrimination may extend beyond the actions reviewed, such corrective action shall include all affected persons.
- d. The Contractor shall promptly investigate all complaints of alleged discrimination made to the Contractor in connection with the obligations under this contract, shall attempt to resolve such complaints, and shall take appropriate corrective action within a reasonable time. If the investigation indicates that the discrimination may affect persons other than the complainant, such corrective action shall include such other persons. Upon completion of each investigation, the Contractor shall inform every complainant of all of the avenues of appeal.

7. Training and Promotion

- a. The Contractor shall assist in locating, qualifying and increasing the skills of minority and female employees and applicants for employment.
- b. Consistent with the Contractor's work force requirements and as permissible under Federal and State regulations, the Contractor shall make full use of training programs, i.e., apprenticeship, and on-the-job training programs for the geographical area of contract performance.
- c. The Contractor shall advise employees and applicants for employment of available training programs and entrance requirements for each.
- d. The Contractor shall periodically review the training and promotion potential of minority and female employees and shall encourage eligible employees to apply for such training and promotion.

8. Unions

If the Contractor relies in whole or in part upon unions as a source of employees, the Contractor shall use his/her best efforts to obtain the cooperation of such unions to increase opportunities for minorities and females within the unions, and to effect referrals by such unions of minority and female employees. Actions by the Contractor, either directly or through a Contractor's association acting as agent, shall include the procedures set forth below:

- a. The Contractor shall use best efforts to develop, in cooperation with the unions, joint training programs aimed toward qualifying more minority and female employees for membership in the unions and increasing the skills of minority and female employees so that they may qualify for higher paying employment.
- b. The Contractor shall use best efforts to incorporate an EEO clause into each union agreement to the end that such union shall be contractually bound to refer applicants without regard to their race, color, religion, sex, national origin, age, or disability.
- c. The Contractor is to obtain information as to the referral practices and policies of the labor union, except that to the extent such information is within the exclusive possession of the labor union and such labor union refuses to furnish such information to the Contractor, the Contractor shall so certify to IDOT and shall set forth what efforts have been made to obtain such information.
- d. In the event the union is unable to provide the Contractor with a reasonable flow of minority and female referrals within the time limit set forth in the collective bargaining agreement, the Contractor shall, through independent recruitment efforts, fill the employment vacancies without regard to race, color, religion, sex, national origin, age, or disability; making full efforts to obtain qualified and/or qualifiable minorities and females. (The U.S. Department of Labor has held that it shall be no excuse that the union with which the Contractor has a collective bargaining agreement providing for exclusive referral failed to refer minorities or female employees). In the event the union referral practice prevents the Contractor from meeting the obligations pursuant to these Special Provisions, such Contractor shall immediately notify IDOT.

9. Selection of Subcontractors, Procurement of Materials, and Leasing of Equipment

The Contractor shall not discriminate on the grounds of race, color, religion, sex, national origin, age, or disability in the selection and retention of subcontractors, including procurement of materials and leases of equipment.

- a. The Contractor shall notify all potential subcontractors and suppliers of his/her EEO obligations under this contract.
- b. Disadvantaged business enterprises (DBE), as defined in 49 CFR Part 23, shall have equal opportunity to compete for and perform subcontracts which the Contractor enters into pursuant to this contract. The Contractor shall use best efforts to solicit bids from and to utilize DBE subcontractors or subcontractors with meaningful minority and female representation among their employees. Contractors shall obtain lists of DBE construction firms from IDOT personnel.
- c. The Contractor shall use his/her best efforts to ensure subcontractor compliance with their EEO obligations.

10. Records and Reports

The Contractor shall keep such records as necessary to document compliance with the EEO requirements. Such records shall be retained for a period of three years following completion of the contract work and shall be available at reasonable times and places for inspection by authorized representatives of IDOT.

- a. The records kept by the Contractor shall document the following:
 - (1) the number of minorities, non-minorities and females employed in each work classification on the project;
 - (2) the progress and efforts being made in cooperation with unions, when applicable, to increase employment opportunities for minorities and females;
 - (3) the progress and efforts being made in locating, hiring, training, qualifying, and upgrading minority and female employees; and
 - (4) the progress and efforts being made in securing the services of DBE subcontractors, or subcontractors with meaningful minority and female representation among their employees.
- b. The Contractor shall submit to IDOT a monthly report every month for the duration of the project, indicating the number of minority, non-minority and female employees currently engaged in each work classification required by contract work and the number of hours worked. This information is to be reported on Form SBE-956. If on-the-job training is being required by special provision, the Contractor will be required to collect and report training data.

State of Illinois
Department of Transportation

SPECIAL PROVISION
FOR
REQUIRED PROVISIONS – STATE CONTRACTS

Effective: April 1 1965
Revised: January 1, 2017

I. SELECTION OF LABOR

The Contractor shall comply with all Illinois statutes pertaining to the selection of labor.

EMPLOYMENT OF ILLINOIS WORKERS DURING PERIODS OF
EXCESSIVE UNEMPLOYMENT

Whenever there is a period of excessive unemployment in Illinois, which is defined herein as any month immediately following two consecutive calendar months during which the level of unemployment in the State of Illinois has exceeded five percent as measured by the United States Bureau of Labor Statistics in its monthly publication of employment and unemployment figures, the Contractor shall employ at least 90 percent Illinois laborers. "Illinois laborer" means any person who has resided in Illinois for at least 30 days and intends to become or remain an Illinois resident.

Other laborers may be used when Illinois laborers as defined herein are not available, or are incapable of performing the particular type of work involved, if so certified by the Contractor and approved by the Engineer. The Contractor may place no more than three of his/her regularly employed non-resident executive and technical experts, who do not qualify as Illinois laborers, to do work encompassed by this Contract during period of excessive unemployment.

This provision applies to all labor, whether skilled, semi-skilled, or unskilled, whether manual or non-manual.

II. EQUAL EMPLOYMENT OPPORTUNITY

In the event of the Contractor's noncompliance with the provisions of this Equal Employment Opportunity Clause, the Illinois Human Rights Act or the Illinois Department of Human Rights Rules and Regulations, the Contractor may be declared ineligible for future contracts or subcontracts with the State of Illinois or any of its political sub-divisions or municipal corporations, and the contract may be cancelled or voided in whole or in part, and such other sanctions or penalties may be imposed or remedies invoked as provided by statute or regulation.

During the performance of this Contract, the Contractor agrees as follows:

1. That it will not discriminate against any employee or applicant for employment because of race, color, religion, sex, sexual orientation, marital status, order of protection status, national origin or ancestry, citizenship status, age, physical or mental disability unrelated to ability, military status, or an unfavorable discharge from military service; and further that it will examine all job classifications to determine if minority persons or women are underutilized and will take appropriate affirmative action to rectify any such underutilization.
2. That, if it hires additional employees in order to perform this contract or any portion hereof, it will determine the availability (in accordance with the Illinois Department of Human Rights Rules and Regulations) of minorities and women in the area(s) from which it may reasonably recruit and it will hire for each job classification for which employees are hired in such a way that minorities and women are not underutilized.
3. That, in all solicitations or advertisements for employees placed by it or on its behalf, it will state that all applicants will be afforded equal opportunity without discrimination because of race, color, religion, sex, sexual orientation, marital status, order of protection status, national origin or ancestry, citizenship status, age, physical or mental disability unrelated to ability, military status, or an unfavorable discharge from military service.
4. That it will send to each labor organization or representative of workers with which it has or is bound by a collective bargaining or other agreement or understanding, a notice advising such labor organization or representative of the Contractor's obligations under the Illinois Human Rights Act and the Illinois Department of Human Rights Rules and Regulations. If any labor organization or representative fails or refuses to cooperate with the Contractor in its efforts to comply with such Act and Rules and Regulations, the Contractor will promptly so notify the Illinois Department of Human Rights and IDOT and will recruit employees from other sources when necessary to fulfill its obligations thereunder.
5. That it will submit reports as required by the Illinois Department of Human Rights Rules and Regulations, furnish all relevant information as may from time to time be requested by the Illinois Department of Human Rights or IDOT, and in all respects comply with the Illinois Human Rights Act and the Illinois Department of Human Rights Rules and Regulations.
6. That it will permit access to all relevant books, records, accounts and work sites by personnel of IDOT and the Illinois Department of Human Rights for purposes of investigation to ascertain compliance with the Illinois Human Rights Act and the Illinois Department of Human Rights Rules and Regulations.
7. That it will include verbatim or by reference the provisions of this clause in every subcontract it awards under which any portion of the contract obligations are undertaken or assumed, so that the provisions will be binding upon the subcontractor. In the same manner as with other provisions of this contract, the Contractor will be liable for compliance with applicable provisions of this clause by subcontractors; and further it will promptly notify IDOT and the Illinois Department of Human Rights in the event any subcontractor fails or refuses to comply with these provisions. In addition, the Contractor will not utilize any subcontractor declared by the Illinois Human Rights Commission to be ineligible for contracts or subcontracts with the State of Illinois or any of its political subdivisions or municipal corporations.

III. SUBLETTING OR ASSIGNING THE CONTRACT

1. The Contractor shall perform with his/her own organization contract work amounting to not less than 51 percent of the original total contract price, except that any items designated by the State as "Specialty Items" may be performed by subcontract and the amount of any such "Specialty Items" so performed may be deducted from the original total contract price before computing the amount of work required to be performed by the Contractor with his/her own organization.
 - a. "His/her own organization" shall be construed to include only worker employed and paid directly by the Contractor and equipment owned or rented by him/her, with or without operators.
 - b. "Specialty Items" shall be construed to be limited to work that requires specialized knowledge, craftsmanship or equipment not ordinarily available in contracting organizations qualified to bid on the contract as a whole and in general are to be limited to minor components of the overall contract.
2. In addition to the 51 percent requirement set forth in paragraph 1 above, the Contractor shall furnish (a) a competent superintendent or foreman who is employed by him/her, who has full authority to direct performance of the work in accordance with the contract requirements, and who is in charge of all construction operations (regardless of who performs the work), and (b) such other of his/her own organizational capability and responsibility (supervision, management, and engineering services) as the State highway department contracting officer determines is necessary to assure the performance of the contract.
3. The Contractor shall not sublet, sell, transfer, assign or otherwise dispose of the contract or contracts or any portion thereof, or of his/her right, title or interest therein, without written consent of the Engineer. In case such consent is given, the Contractor will be permitted to sublet a portion thereof, but shall perform with the Contractor's own organization, work amounting to not less than 51 percent of the total contract cost, except that any items designated in the contract as "specialty items" may be performed by subcontract and the cost of any such specialty items so performed by subcontract may be deducted from the total cost before computing the amount of work required to be performed by the Contractor with his/her own organization. Materials purchased or produced by the Contractor must be incorporated into the project by the Contractor's own organization if their cost is to be applied to the 50 percent requirement.

No subcontracts, or transfer of contract, shall in any case release the Contractor of his/her liability under the contract and bonds. All transactions of the Engineer shall be with the Contractor. The Contractor shall have representative on the job at all times when either contract or subcontract work is being performed.

All requests to subcontract shall contain a certification that the subcontract agreement exists in writing and physically contains the required Federal and State Equal Employment Opportunity provisions and Labor compliance provisions, including the contract minimum wage requirements. The Contractor shall permit Department or Federal representatives to examine the subcontract agreements upon notice.

4. Any items that have been selected as "Specialty Items" for the contract are listed as such in the Special Provisions, bid schedule, or elsewhere in the contract documents.
5. No portion of the contract shall be sublet, assigned or otherwise disposed of, except with the written consent of the State highway department contracting officer, or his/her authorized representative, and such consent when given shall not be construed to relieve the Contractor of any responsibility for the fulfillment of the contract. Request for permission to sublet, assign or otherwise dispose of any portion of the contract shall be in writing and accompanied by (a) a showing that the organization which will perform the work is particularly experienced and equipped for such work, and (b) an assurance by the Contractor that the labor standards provisions set forth in this contract shall apply to labor performed on all work encompassed by the request.

IV. COMPLIANCE WITH THE PREVAILING WAGE ACT

1. **Prevailing Wages.** All wages paid by the Contractor and each subcontractor shall be in compliance with The Prevailing Wage Act (820 ILCS 130), as amended, except where a prevailing wage violates a federal law, order, or ruling, the rate conforming to the federal law, order, or ruling shall govern. The Contractor shall be responsible to notify each subcontractor of the wage rates set forth in this contract and any revisions thereto. If the Department of Labor revises the wage rates, the Contractor will not be allowed additional compensation on account of said revisions. Current wage rate information shall be obtained by visiting the Department of Labor website at <http://www.illinois.gov/idol/Pages/default.aspx>. It is the responsibility of the Contractor to review the rates applicable to the work of this contract at regular intervals in order to insure the timely payment of current rates. Provision of this information to the Contractor by means of the Department of Labor website satisfies the notification of revisions by the Department to the Contractor pursuant to the Act, and the Contractor agrees that no additional notice is required.
2. **Payroll Records.** The Contractor and each subcontractor shall make and keep, for a period of three years from the later of the date of final payment under the contract or completion of the contract, records of the wages paid to his/her workers. The payroll records shall include each worker's name, address, telephone number, social security number, classification, rate of pay, number of hours worked each day, starting and ending times of work each day, total hours worked each week, itemized deductions made, and actual wages paid. Upon seven business days' notice, these records shall be available at a location within the State, during reasonable hours, for inspection by the Department or the Department of Labor; and Federal, State, or local law enforcement agencies and prosecutors.
3. **Submission of Payroll Records.** The Contractor and each subcontractor shall submit payroll records to the Engineer each week from the start to the completion of their respective work, except that full social security numbers and home addresses shall not be included on weekly transmittals. Instead the payrolls shall include an identification number for each employee (e.g., the last four digits of the employee's social security number). In addition, starting and ending times of work each day may be omitted from the payroll records submitted to the Engineer. The submittals shall be on the Department's form SBE 48, or an approved facsimile. When there has been no activity during a work week, a payroll record shall still be submitted with the appropriate box ("No Work", "Suspended", or "Complete") checked on the form.

Each submittal shall be accompanied by a statement signed by the Contractor or subcontractor, or an officer, employee, or officer thereof, which avers that: (i) he or she has examined the records and such records are true and accurate; (ii) the hourly rate paid to each worker is not less than the general prevailing rate of hourly wages required by the Act; and (iii) the Contractor or subcontractor is aware that filing a payroll record that he/she knows to be false is a Class A misdemeanor.

4. Employee Interviews. The Contractor and each subcontractor shall permit his/her employees to be interviewed on the job, during working hours, by compliance investigators of the Department or the Department of Labor.

V. NONSEGREGATED FACILITIES

(Applicable to State Financed Construction Contracts and related subcontracts exceeding \$10,000 which are not exempt from the Equal Opportunity clause).

By submission of this bid, the execution of this contract or subcontract, or the consummation of this material supply agreement, as appropriate, the bidder, construction Contractor, subcontractor, or material supplier, as appropriate, certifies that (s)he does not maintain or provide for his/her employees any segregated facilities at any of his/her establishments, and that (s)he does not permit his/her employees to perform their services at any location, under his/her control, where segregated facilities are maintained. (S)He certifies further that (s)he will not maintain or provide for his/her employees any segregated facilities at any of his/her establishments, and that (s)he will not permit his/her employees to perform their services at any location, under his/her control, where segregated facilities are maintained. (S)He agrees that a breach of this certification is a violation of the Equal Opportunity clause in this contract. As used in this certification, the term "segregated facilities" means any waiting rooms, work areas, restrooms and washrooms, restaurants and other eating areas, time clocks, locker rooms and other storage or dressing areas, parking lots, drinking fountains, recreation or entertainment areas, transportation, and housing facilities provided for employees which are segregated by explicit directive or are in fact segregated on the basis of race, creed, color, or national origin, because of habit, local custom, or otherwise. (S)He agrees that (except where he/she has obtained identical certifications from proposed subcontractors and material suppliers for specific time periods), he/she will obtain identical certifications from proposed subcontractors or material suppliers prior to the award of subcontracts or the consummation of material supply agreements, exceeding \$10,000 which are not exempt from the provisions of the Equal Opportunity clause, and that (s)he will retain such certifications in his/her files.

State of Illinois
Department of Transportation

SPECIAL PROVISION
FOR
SECTION 80 PROSECUTION AND PROGRESS

This Special Provision amends the provisions of the Standard Specifications for Construction of Airports, adopted April 1, 2012 and shall be construed to be a part thereof, superseding any conflicting provisions thereof applicable to the work under the contract.

80-09 FAILURE TO COMPLETE ON TIME.

DELETE: "See contract documents for current schedule of deductions."

ADD:

Schedule of Deductions for Each Day of Overrun in Contract Time			
Original Contract Amount		Daily Charges	
From More Than	To and Including	Calendar Day	Work Day
\$ 0	\$ 100,000	\$ 475	\$ 675
100,000	500,000	750	1,050
500,000	1,000,000	1,025	1,425
1,000,000	3,000,000	1,275	1,725
3,000,000	6,000,000	1,425	2,000
6,000,000	12,000,000	2,300	3,450
12,000,000	And over	6,775	9,525

State of Illinois
Department of Transportation

SPECIAL PROVISION
FOR
SECTION 90 MEASUREMENT AND PAYMENT

This Special Provision amends the provisions of the Standard Specifications for Construction of Airports, adopted April 1, 2012 and shall be construed to be a part thereof, superseding any conflicting provisions thereof applicable to the work under the contract.

90-07 PARTIAL PAYMENTS.

DELETE: The entire section.

ADD: Partial payments will be made to the Contractor at least once each month as the work progresses. The payments will be based upon estimates, prepared by the Resident Engineer, of the value of the work performed and materials complete and in place in accordance with the contract, plans, and specifications. Such partial payments may also include the delivered actual cost of those materials stockpiled and stored in accordance with the Section 90-08 PAYMENT FOR MATERIALS ON HAND. From the amount of partial payment so determined on Federal-Aid projects, there shall be deducted an amount up to ten percent of the cost of the completed work which shall be retained until all conditions necessary for financial closeout of the project are satisfied. The amount of the estimate approved as due for payment will be vouchered by the Department and presented to the State Comptroller for payment. No amount less than \$1,000.00 will be approved for payment other than the final payment. A final voucher for under \$5.00 shall not be paid except through electronic funds transfer. (15 ILCS 405/9(b-1))

It is understood and agreed that the Contractor shall not be entitled to demand or receive partial payment based on quantities of work in excess of those provided in the proposal or covered by approved change orders, except when such excess quantities have been determined by the Engineer to be a part of the final quantity for the item of work in question.

No partial payment shall bind the Department to the acceptance of any materials or work in place as to quality or quantity. All partial payments are subject to correction at the time of final payment as provided in Section 90-09 ACCEPTANCE AND FINAL PAYMENT.

Progress payments may be reduced by liens filed pursuant to Section 23(c) of the Mechanics Lien Act, 770 ILCS 60/23(c).

If a Contractor or subcontractor has defaulted on a loan issued under the Department's Disadvantaged Business Revolving Loan Program (20 ILCS 2705/2705-610) progress payments may be reduced pursuant to the terms of that loan agreement. In such cases, the amount of the estimate related to the work performed by the Contractor or subcontractor, in default of the loan agreement, will be offset, in whole or in part, and vouchered by the Department to the Working Capital Revolving Fund or designated escrow account. Payment for the work shall be considered as issued and received by the Contractor or subcontractor on the date of the offset voucher. Further, the amount of the offset voucher shall be a credit against the Department's obligation to pay the Contractor, the Contractor's obligation to pay the subcontractor, and the Contractor's or subcontractor's total loan indebtedness to the Department. The offset shall continue until such time as the entire loan indebtedness is satisfied. The Department will notify the Contractor and Fund Control Agent in a timely manner of such offset. The Contractor or subcontractor shall not be entitled to additional payment in consideration of the offset.

In accordance with 49 USC § 47111, the Department will not make payments totaling more than 90 percent of the contract until all conditions necessary for financial closeout of the project are satisfied.

The failure to perform any requirement, obligation, or term of the contract by the Contractor shall be reason for withholding any progress payments until the Department determines that compliance has been achieved.

90-10 TRUST AGREEMENT OPTION.

DELETE: The entire section.

STATE OF ILLINOIS

SPECIAL PROVISIONS

The following Special Provisions supplement the "Standard Specifications for Construction of Airports," adopted April 1, 2012, and the Special Provisions included herein which apply to and govern the airport improvement of: Rehabilitate Terminal Entrance Road and Auto Parking Lot at Schaumburg Regional, Contract SH029, and in case of conflict with any part or parts of said Specifications, the said Special Provisions shall take precedence and shall govern.

SPECIAL PROVISION FOR COMPLETION TIME VIA CALENDAR DAYS

It being understood and agreed that the completion within the time limit is an essential part of the contract, the bidder agrees to complete the work within **40 calendar days**, unless additional time is granted by the Engineer in accordance with the provisions of the specifications. In case of failure to complete the work on or before the time named herein, or within such extra time as may have been allowed by extensions, the bidder agrees that the Department of Transportation shall withhold from such sum as may be due him/her under the terms of this contract, the costs, as set forth in Section 80-09 Failure to Complete on Time of the Standard Specifications, which costs shall be considered and treated not as a penalty but as damages due to the State from the bidder by reason of the failure of the bidder to complete the work within the time specified in the contract.

CONSTRUCTION AIR QUALITY – DIESEL VEHICLE EMISSIONS CONTROL (BDE)

Effective: April 1, 2009

Revised: January 2, 2012

Diesel Vehicle Emissions Control. The reduction of construction air emissions shall be accomplished by using cleaner burning diesel fuel. The term "equipment" refers to any and all diesel fuel powered devices rated at 50 hp and above, to be used on the project site in excess of seven calendar days over the course of the construction period on the project site (including any "rental" equipment).

All equipment on the jobsite, with engine ratings of 50 hp and above, shall be required to: use Ultra Low Sulfur Diesel fuel (ULSD) exclusively (15 ppm sulfur content or less).

Diesel powered equipment in non-compliance will not be allowed to be used on the project site, and is also subject to a notice of non-compliance as outlined below.

The Contractor shall certify that only ULSD will be used in all jobsite equipment. The certification shall be presented to the Department prior to the commencement of the work.

If any diesel powered equipment is found to be in non-compliance with any portion of this specification, the Engineer will issue the Contractor a notice of non-compliance and identify an appropriate period of time, as outlined below under environmental deficiency deduction, in which to bring the equipment into compliance or remove it from the project site.

Any costs associated with bringing any diesel powered equipment into compliance with these diesel vehicle emissions controls shall be considered as included in the contract unit prices bid for the various items of work involved and no additional compensation will be allowed. The Contractor's compliance with this notice and any associated regulations shall also not be grounds for a claim.

Environmental Deficiency Deduction. When the Engineer is notified, or determines that an environmental control deficiency exists, he/she will notify the Contractor in writing, and direct the Contractor to correct the deficiency within a specified time period. The specified time-period, which begins upon Contractor notification, will be from 1/2 hour to 24 hours long, based on the urgency of the situation and the nature of the deficiency. The Engineer shall be the sole judge regarding the time period.

The deficiency will be based on lack of repair, maintenance and diesel vehicle emissions control.

If the Contractor fails to correct the deficiency within the specified time frame, a daily monetary deduction will be imposed for each calendar day or fraction thereof the deficiency continues to exist. The calendar day(s) will begin when the time period for correction is exceeded and end with the Engineer's written acceptance of the correction. The daily monetary deduction will be \$1,000.00 for each deficiency identified.

If a Contractor or subcontractor accumulates three environmental deficiency deductions in a contract period, the Contractor will be shutdown until the deficiency is corrected. Such a shutdown will not be grounds for any extension of contract time, waiver of penalties, or be grounds for any claim.

CONSTRUCTION AIR QUALITY – IDLING RESTRICTION (BDE)

Effective: April 1, 2009

Idling Restrictions. The Contractor shall establish truck-staging areas for all diesel powered vehicles that are waiting to load or unload material at the jobsite. Staging areas shall be located where the diesel emissions from the equipment will have a minimum impact on adjacent sensitive receptors. The Department will review the selection of staging areas, whether within or outside the existing highway right-of-way, to avoid locations near sensitive areas

or populations to the extent possible. Sensitive receptors include, but are not limited to, hospitals, schools, residences, motels, hotels, daycare facilities, elderly housing and convalescent facilities. Diesel powered engines shall also be located as far away as possible from fresh air intakes, air conditioners, and windows. The Engineer will approve staging areas before implementation.

Diesel powered vehicle operators may not cause or allow the motor vehicle, when it is not in motion, to idle for more than a total of 10 minutes within any 60 minute period, except under any of the following circumstances:

- 1) The motor vehicle has a gross vehicle weight rating of less than 8000 lb (3630 kg).
- 2) The motor vehicle idles while forced to remain motionless because of on-highway traffic, an official traffic control device or signal, or at the direction of a law enforcement official.
- 3) The motor vehicle idles when operating defrosters, heaters, air conditioners, or other equipment solely to prevent a safety or health emergency.
- 4) A police, fire, ambulance, public safety, other emergency or law enforcement motor vehicle, or any motor vehicle used in an emergency capacity, idles while in an emergency or training mode and not for the convenience of the vehicle operator.
- 5) The primary propulsion engine idles for maintenance, servicing, repairing, or diagnostic purposes if idling is necessary for such activity.
- 6) A motor vehicle idles as part of a government inspection to verify that all equipment is in good working order, provided idling is required as part of the inspection.
- 7) When idling of the motor vehicle is required to operate auxiliary equipment to accomplish the intended use of the vehicle (such as loading, unloading, mixing, or processing cargo; controlling cargo temperature; construction operations, lumbering operations; oil or gas well servicing; or farming operations), provided that this exemption does not apply when the vehicle is idling solely for cabin comfort or to operate non-essential equipment such as air conditioning, heating, microwave ovens, or televisions.
- 8) When the motor vehicle idles due to mechanical difficulties over which the operator has no control.
- 9) The outdoor temperature is less than 32 °F (0 °C) or greater than 80 °F (26 °C).

When the outdoor temperature is greater than or equal to 32 °F (0 °C) or less than or equal to 80 °F (26 °C), a person who operates a motor vehicle operating on diesel fuel shall not cause or allow the motor vehicle to idle for a period greater than 30 minutes in any 60 minute period while waiting to weigh, load, or unload cargo or freight, unless the vehicle is in a line of vehicles that regularly and periodically moves forward.

The above requirements do not prohibit the operation of an auxiliary power unit or generator set as an alternative to idling the main engine of a motor vehicle operating on diesel fuel.

Environmental Deficiency Deduction. When the Engineer is notified, or determines that an environmental control deficiency exists based on non-compliance with the idling restrictions, he/she will notify the Contractor, and direct the Contractor to correct the deficiency.

If the Contractor fails to correct the deficiency a monetary deduction will be imposed. The monetary deduction will be \$1,000.00 for each deficiency identified.

SPECIAL PROVISION FOR DISADVANTAGED BUSINESS ENTERPRISE PARTICIPATION

Effective: September 1, 2000

Revised: April 2, 2018

FEDERAL OBLIGATION. The Department of Transportation, as a recipient of federal financial assistance, is required to take all necessary and reasonable steps to ensure nondiscrimination in the award and administration of contracts. Consequently, the federal regulatory provisions of 49 CFR Part 26 apply to this contract concerning the utilization of disadvantaged business enterprises. For the purposes of this Special Provision, a disadvantaged business enterprise (DBE) means a business certified by the Department in accordance with the requirements of 49 CFR Part 26 and listed in the Illinois Unified Certification Program (IL UCP) DBE Directory.

STATE OBLIGATION. This Special Provision will also be used by the Department to satisfy the requirements of the Business Enterprise for Minorities, Females, and Persons with Disabilities Act, 30 ILCS 575. When this Special Provision is used to satisfy state law requirements on 100 percent state-funded contracts, the federal government has no involvement in such contracts (not a federal-aid contract) and no responsibility to oversee the implementation of this Special Provision by the Department on those contracts. DBE participation on 100 percent state-funded contracts will not be credited toward fulfilling the Department's annual overall DBE goal required by the US Department of Transportation to comply with the federal DBE program requirements.

CONTRACTOR ASSURANCE. The Contractor makes the following assurance and agrees to include the assurance in each subcontract that the Contractor signs with a subcontractor.

The Contractor, subrecipient, or subcontractor shall not discriminate on the basis of race, color, national origin, or sex in the performance of this contract. The Contractor shall carry out applicable requirements of 49 CFR Part 26 in the award and administration of contracts funded in whole or in part with federal or state funds. Failure by the Contractor to carry out these requirements is a material breach of this contract, which may result in the termination of this contract or such other remedy as the recipient deems appropriate, which may include, but is not limited to:

- (a) Withholding progress payments;
- (b) Assessing sanctions;
- (c) Liquidated damages; and/or
- (d) Disqualifying the Contractor from future bidding as non-responsible.

OVERALL GOAL SET FOR THE DEPARTMENT. As a requirement of compliance with 49 CFR Part 26, the Department has set an overall goal for DBE participation in its federally assisted contracts. That goal applies to all federal-aid funds the Department will expend in its federally assisted contracts for the subject reporting fiscal year. The Department is required to make a good faith effort to achieve the overall goal. The dollar amount paid to all approved DBE companies performing work called for in this contract is eligible to be credited toward fulfillment of the Department's overall goal.

CONTRACT GOAL TO BE ACHIEVED BY THE CONTRACTOR. This contract includes a specific DBE utilization goal established by the Department. The goal has been included because the Department has determined that the work of this contract has subcontracting opportunities that may be suitable

for performance by DBE companies. The determination is based on an assessment of the type of work, the location of the work, and the availability of DBE companies to do a part of the work. The assessment indicates that, in the absence of unlawful discrimination, and in an arena of fair and open competition, DBE companies can be expected to perform 4.0% of the work. This percentage is set as the DBE participation goal for this contract. Consequently, in addition to the other award criteria established for this contract, the Department will only award this contract to a bidder who makes a good faith effort to meet this goal of DBE participation in the performance of the work. A bidder makes a good faith effort for award consideration if either of the following is done in accordance with the procedures set for in this Special Provision:

- (a) The bidder documents that enough DBE participation has been obtained to meet the goal or,
- (b) The bidder documents that a good faith effort has been made to meet the goal, even though the effort did not succeed in obtaining enough DBE participation to meet the goal.

DBE LOCATOR REFERENCES. Bidders shall consult the IL UCP DBE Directory as a reference source for DBE-certified companies. In addition, the Department maintains a letting and item specific DBE locator information system whereby DBE companies can register their interest in providing quotes on particular bid items advertised for letting. Information concerning DBE companies willing to quote work for particular contracts may be obtained by contacting the Department's Bureau of Small Business Enterprises at telephone number (217) 785-4611, or by visiting the Department's website at: <http://www.idot.illinois.gov/doing-business/certifications/disadvantaged-business-enterprise-certification/il-ucp-directory/index>.

BIDDING PROCEDURES. Compliance with this Special Provision is required prior to the award of the contract and the failure of the low bidder to comply will render the bid not responsive.

In order to assure the timely award of the contract, the low bidder shall submit:

- (a) The bidder shall submit a DBE Utilization Plan on completed Department forms SBE 2025 and 2026.
 - (1) The final Utilization Plan must be submitted within five calendar days after the date of the letting in accordance with subsection (a)(2) of Bidding Procedures.
 - (2) To meet the five day requirement, the bidder may send the Utilization Plan electronically by scanning and sending to DOT.DBE.UP@illinois.gov or faxing to (217) 785-1524. The subject line must include the bid Item Number and the Letting date. The Utilization Plan should be sent as one .pdf file, rather than multiple files and emails for the same Item Number. It is the responsibility of the bidder to obtain confirmation of email or fax delivery.

Alternatively, the Utilization Plan may be sent by certified mail or delivery service within the five calendar day period. If a question arises concerning the mailing date of a Utilization Plan, the mailing date will be established by the U.S. Postal Service postmark on the certified mail receipt from the U.S. Postal Service or the receipt issued by a delivery service when the Utilization Plan is received by the Department. It is the responsibility of the bidder to ensure the postmark or receipt date is affixed within the five days if the bidder intends to rely upon mailing or delivery to satisfy the submission day requirement. The Utilization Plan is to be submitted to:

Illinois Department of Transportation
Bureau of Small Business Enterprises
Contract Compliance Section
2300 South Dirksen Parkway, Room 319
Springfield, Illinois 62764

The Department will not accept a Utilization Plan if it does not meet the five day submittal requirement and the bid will be declared not responsive. In the event the bid is declared not responsive due to a failure to submit a Utilization Plan or failure to comply with the bidding procedures set forth herein, the Department may elect to cause the forfeiture of the penal sum of the bidder's proposal guaranty, and may deny authorization to bid the project if re-advertised for bids. The Department reserves the right to invite any other bidder to submit a Utilization Plan at any time for award consideration.

- (b) The Utilization Plan shall indicate that the bidder either has obtained sufficient DBE participation commitments to meet the contract goal or has not obtained enough DBE participation commitments in spite of a good faith effort to meet the goal. The Utilization Plan shall further provide the name, telephone number, and telefax number of a responsible official of the bidder designated for purposes of notification of Utilization Plan approval or disapproval under the procedures of this Special Provision.
- (c) The Utilization Plan shall include a DBE Participation Commitment Statement, Department form SBE 2025, for each DBE proposed for the performance of work to achieve the contract goal. For bidding purposes, submission of the completed SBE 2025 forms, signed by the DBEs and scanned or faxed to the bidder will be acceptable as long as the original is available and provided upon request. All elements of information indicated on the said form shall be provided, including but not limited to the following:
 - (1) The names and addresses of DBE firms that will participate in the contract;
 - (2) A description, including pay item numbers, of the work each DBE will perform;
 - (3) The dollar amount of the participation of each DBE firm participating. The dollar amount of participation for identified work shall specifically state the quantity, unit price, and total subcontract price for the work to be completed by the DBE. If partial pay items are to be performed by the DBE, indicate the portion of each item, a unit price where appropriate and the subcontract price amount;
 - (4) DBE Participation Commitment Statements, form SBE 2025, signed by the bidder and each participating DBE firm documenting the commitment to use the DBE subcontractors whose participation is submitted to meet the contract goal;
 - (5) If the bidder is a joint venture comprised of DBE companies and non-DBE companies, the Utilization Plan must also include a clear identification of the portion of the work to be performed by the DBE partner(s); and,
 - (6) If the contract goal is not met, evidence of good faith efforts; the documentation of good faith efforts must include copies of each DBE and non-DBE subcontractor quote submitted to the bidder when a non-DBE subcontractor is selected over a DBE for work on the contract.

GOOD FAITH EFFORT PROCEDURES. The contract will not be awarded until the Utilization Plan submitted by the apparent successful bidder is approved. All information submitted by the bidder must be complete, accurate and adequately document that enough DBE participation has been obtained or document that good faith efforts of the bidder, in the event enough DBE participation has not been obtained, before the Department will commit to the performance of the contract by the bidder. The Utilization Plan will be approved by the Department if the Utilization Plan documents sufficient commercially useful DBE work to meet the contract goal or the bidder submits sufficient documentation of a good faith effort to meet the contract goal pursuant to 49 CFR Part 26, Appendix A. The Utilization Plan will not be approved by the Department if the Utilization Plan does not document sufficient DBE participation to meet the contract goal unless the apparent successful bidder documented in the Utilization Plan that it made a good faith effort to meet the goal. This means that the bidder must show that all necessary and reasonable steps were taken to achieve the contract goal. Necessary and reasonable steps are those which, by their scope, intensity and appropriateness to the objective, could reasonably be expected to obtain sufficient DBE participation, even if they were not successful. The Department will consider the quality, quantity, and intensity of the kinds of efforts that the bidder has made. Mere *pro forma* efforts, in other words, efforts done as a matter of form, are not good faith efforts; rather, the bidder is expected to have taken genuine efforts that would be reasonably expected of a bidder actively and aggressively trying to obtain DBE participation sufficient to meet the contract goal.

(a) The following is a list of types of action that the Department will consider as part of the evaluation of the bidder's good faith efforts to obtain participation. These listed factors are not intended to be a mandatory checklist and are not intended to be exhaustive. Other factors or efforts brought to the attention of the Department may be relevant in appropriate cases, and will be considered by the Department.

(1) Soliciting through all reasonable and available means (e.g. attendance at pre-bid meetings, advertising and/or written notices) the interest of all certified DBE companies that have the capability to perform the work of the contract. The bidder must solicit this interest within sufficient time to allow the DBE companies to respond to the solicitation. The bidder must determine with certainty if the DBE companies are interested by taking appropriate steps to follow up initial solicitations.

(2) Selecting portions of the work to be performed by DBE companies in order to increase the likelihood that the DBE goals will be achieved. This includes, where appropriate, breaking out contract work items into economically feasible units to facilitate DBE participation, even when the prime Contractor might otherwise prefer to perform these work items with its own forces.

(3) Providing interested DBE companies with adequate information about the plans, specifications, and requirements of the contract in a timely manner to assist them in responding to a solicitation.

(4) a. Negotiating in good faith with interested DBE companies. It is the bidder's responsibility to make a portion of the work available to DBE subcontractors and suppliers and to select those portions of the work or material needs consistent with the available DBE subcontractors and suppliers, so as to facilitate DBE participation. Evidence of such negotiation includes the names, addresses, and telephone numbers of DBE companies that were considered; a description of the information provided regarding the plans and specifications for the work selected for subcontracting; and evidence as to why additional agreements could not be reached for DBE companies to perform the work.

b. A bidder using good business judgment would consider a number of factors in negotiating with subcontractors, including DBE subcontractors, and would take a firm's price and capabilities as well as contract goals into consideration. However, the fact that there may be some additional costs involved in finding and using DBE companies is not in itself sufficient reason for a bidder's failure to meet the contract DBE goal, as long as such costs are reasonable. Also the ability or desire of a bidder to perform the work of a contract with its own organization does not relieve the bidder of the responsibility to make good faith efforts. Bidders are not, however, required to accept higher quotes from DBE companies if the price difference is excessive or unreasonable. In accordance with subsection (c)(6) of the above Bidding Procedures, the documentation of good faith efforts must include copies of each DBE and non-DBE subcontractor quote submitted to the bidder when a non-DBE subcontractor was selected over a DBE for work on the contract.

(5) Not rejecting DBE companies as being unqualified without sound reasons based on a thorough investigation of their capabilities. The bidder's standing within its industry, membership in specific groups, organizations, or associations and political or social affiliations (for example union vs. non-union employee status) are not legitimate causes for the rejection or non-solicitation of bids in the bidder's efforts to meet the project goal.

(6) Making efforts to assist interested DBE companies in obtaining bonding, lines of credit, or insurance as required by the recipient or Contractor.

(7) Making efforts to assist interested DBE companies in obtaining necessary equipment, supplies, materials, or related assistance or services.

(8) Effectively using the services of available minority/women community organizations; minority/women contractors' groups; local, state, and federal minority/women business assistance offices; and other organizations as allowed on a case-by-case basis to provide assistance in the recruitment and placement of DBE companies.

(b) If the Department determines that the apparent successful bidder has made a good faith effort to secure the work commitment of DBE companies to meet the contract goal, the Department will award the contract provided that it is otherwise eligible for award. If the Department determines that the bidder has failed to meet the requirements of this Special Provision or that a good faith effort has not been made, the Department will notify the responsible company official designated in the Utilization Plan that the bid is not responsive. The notification shall include a statement of reasons for the determination. If the Utilization Plan is not approved because it is deficient as a technical matter, unless waived by the Department, the bidder will be notified and will be allowed no more than a five calendar day period in order to cure the deficiency.

(c) The bidder may request administrative reconsideration of a determination adverse to the bidder within the five working days after the receipt of the notification date of the determination by delivering the request to the Department of Transportation, Bureau of Small Business Enterprises, Contract Compliance Section, 2300 South Dirksen Parkway, Room 319, Springfield, Illinois 62764 (Telefax: (217) 785-1524). Deposit of the request in the United States mail on or before the fifth business day shall not be deemed delivery. The determination shall become final if a request is not made and delivered. A request may provide additional written documentation or argument concerning the issues raised in the determination statement of reasons, provided the documentation and arguments address efforts made prior to submitting the bid. The request will be forwarded to the Department's Reconsideration Officer. The Reconsideration Officer will extend an opportunity to the bidder to meet in person in order to consider all issues of documentation and whether the bidder made a good faith effort to meet the goal. After the review by the Reconsideration Officer, the bidder will be sent a written decision within ten working days after receipt of the request for reconsideration, explaining the basis for finding that the bidder did or did not meet the goal or make adequate good faith efforts to do so. A final decision by the Reconsideration Officer that a good faith effort was made shall approve the Utilization Plan submitted by the bidder and shall clear the contract for award. A final decision that a good faith effort was not made shall render the bid not responsive.

CALCULATING DBE PARTICIPATION. The Utilization Plan values represent work anticipated to be performed and paid for upon satisfactory completion. The Department is only able to count toward the achievement of the overall goal and the contract goal the value of payments made for the work actually performed by DBE companies. In addition, a DBE must perform a commercially useful function on the contract to be counted. A commercially useful function is generally performed when the DBE is responsible for the work and is carrying out its responsibilities by actually performing, managing, and supervising the work involved. The Department and Contractor are governed by the provisions of 49 CFR Part 26.55(c) on questions of commercially useful functions as it affects the work. Specific counting guidelines are provided in 49 CFR Part 26.55, the provisions of which govern over the summary contained herein.

- (a) DBE as the Contractor: 100 percent goal credit for that portion of the work performed by the DBE's own forces, including the cost of materials and supplies. Work that a DBE subcontracts to a non-DBE does not count toward the DBE goals.
- (b) DBE as a joint venture Contractor: 100 percent goal credit for that portion of the total dollar value of the contract equal to the distinct, clearly defined portion of the work performed by the DBE's own forces.
- (c) DBE as a subcontractor: 100 percent goal credit for the work of the subcontract performed by the DBE's own forces, including the cost of materials and supplies, excluding the purchase of materials and supplies or the lease of equipment by the DBE subcontractor from the prime Contractor or its affiliates. Work that a DBE subcontractor in turn subcontracts to a non-DBE does not count toward the DBE goal.
- (d) DBE as a trucker: 100 percent goal credit for trucking participation provided the DBE is responsible for the management and supervision of the entire trucking operation for which it is responsible. At least one truck owned, operated, licensed, and insured by the DBE must be used on the contract. Credit will be given for the following:
 - (1) The DBE may lease trucks from another DBE firm, including an owner-operator who is certified as a DBE. The DBE who leases trucks from another DBE receives credit for the total value of the transportation services the lessee DBE provides on the contract.
 - (2) The DBE may also lease trucks from a non-DBE firm, including from an owner-operator. The DBE who leases trucks from a non-DBE is entitled to credit only for the fee or commission it receives as a result of the lease arrangement.
- (e) DBE as a material supplier:
 - (1) 60 percent goal credit for the cost of the materials or supplies purchased from a DBE regular dealer.
 - (2) 100 percent goal credit for the cost of materials or supplies obtained from a DBE manufacturer.
 - (3) 100 percent credit for the value of reasonable fees and commissions for the procurement of materials and supplies if not a DBE regular dealer or DBE manufacturer.

CONTRACT COMPLIANCE. Compliance with this Special Provision is an essential part of the contract. The Department is prohibited by federal regulations from crediting the participation of a DBE included in the Utilization Plan toward either the contract goal or the Department's overall goal until the amount to be applied toward the goals has been paid to the DBE. The following administrative procedures and remedies govern the compliance by the Contractor with the contractual obligations established by the Utilization Plan. After approval of the Utilization Plan and award of the contract, the Utilization Plan and individual DBE Participation Statements become part of the contract. If the Contractor did not succeed in obtaining enough DBE participation to achieve the advertised contract goal, and the Utilization Plan was approved and contract awarded based upon a determination of good faith, the total dollar value of DBE work calculated in the approved Utilization Plan as a percentage of the awarded contract value shall become the amended contract goal. All work indicated for performance by an approved DBE shall be performed, managed, and supervised by the DBE executing the DBE Participation Commitment Statement.

- (a) **NO AMENDMENT.** No amendment to the Utilization Plan may be made without prior written approval from the Department's Bureau of Small Business Enterprises. All requests for amendment to the Utilization Plan shall be submitted to the Department of Transportation, Bureau of Small Business Enterprises, Contract Compliance Section, 2300 South Dirksen Parkway, Room 319, Springfield, Illinois 62764. Telephone number (217) 785-4611. Telefax number (217) 785-1524.
- (b) **CHANGES TO WORK.** Any deviation from the DBE condition-of-award or contract plans, specifications, or special provisions must be approved, in writing, by the Department as provided elsewhere in the Contract. The Contractor shall notify affected DBEs in writing of any changes in the scope of work which result in a reduction in the dollar amount condition-of-award to the contract. Where the revision includes work committed to a new DBE subcontractor, not previously involved in the project, then a Request for Approval of Subcontractor, Department form BC 260A or AER 260A, must be signed and submitted. If the commitment of work is in the form of additional tasks assigned to an existing subcontract, then a new Request for Approval of Subcontractor shall not be required. However, the Contractor must document efforts to assure that the existing DBE subcontractor is capable of performing the additional work and has agreed in writing to the change.
- (c) **SUBCONTRACT.** The Contractor must provide DBE subcontracts to IDOT upon request. Subcontractors shall ensure that all lower tier subcontracts or agreements with DBEs to supply labor or materials be performed in accordance with this Special Provision.
- (d) **ALTERNATIVE WORK METHODS.** In addition to the above requirements for reductions in the condition of award, additional requirements apply to the two cases of Contractor-initiated work substitution proposals. Where the contract allows alternate work methods which serve to delete or create underruns in condition of award DBE work, and the Contractor selects that alternate method or, where the Contractor proposes a substitute work method or material that serves to diminish or delete work committed to a DBE and replace it with other work, then the Contractor must demonstrate one of the following:
 - (1) That the replacement work will be performed by the same DBE (as long as the DBE is certified in the respective item of work) in a modification of the condition of award; or
 - (2) That the DBE is aware that its work will be deleted or will experience underruns and has agreed in writing to the change. If this occurs, the Contractor shall substitute other work of equivalent value to a certified DBE or provide documentation of good faith efforts to do so; or
 - (3) That the DBE is not capable of performing the replacement work or has declined to perform the work at a reasonable competitive price. If this occurs, the Contractor shall substitute other work of equivalent value to a certified DBE or provide documentation of good faith efforts to do so.

(e) **TERMINATION AND REPLACEMENT PROCEDURES.** The Contractor shall not terminate or replace a DBE listed on the approved Utilization Plan, or perform with other forces work designated for a listed DBE except as provided in this Special Provision. The Contractor shall utilize the specific DBEs listed to perform the work and supply the materials for which each is listed unless the Contractor obtains the Department's written consent as provided in subsection (a) of this part. Unless Department consent is provided for termination of a DBE subcontractor, the Contractor shall not be entitled to any payment for work or material unless it is performed or supplied by the DBE in the Utilization Plan.

As stated above, the Contractor shall not terminate or replace a DBE subcontractor listed in the approved Utilization Plan without prior written consent. This includes, but is not limited to, instances in which the Contractor seeks to perform work originally designated for a DBE subcontractor with its own forces or those of an affiliate, a non-DBE firm, or with another DBE firm. Written consent will be granted only if the Bureau of Small Business Enterprises agrees, for reasons stated in its concurrence document, that the Contractor has good cause to terminate or replace the DBE firm. Before transmitting to the Bureau of Small Business Enterprises any request to terminate and/or substitute a DBE subcontractor, the Contractor shall give notice in writing to the DBE subcontractor, with a copy to the Bureau, of its intent to request to terminate and/or substitute, and the reason for the request. The Contractor shall give the DBE five days to respond to the Contractor's notice. The DBE so notified shall advise the Bureau and the Contractor of the reasons, if any, why it objects to the proposed termination of its subcontract and why the Bureau should not approve the Contractor's action. If required in a particular case as a matter of public necessity, the Bureau may provide a response period shorter than five days.

For purposes of this paragraph, good cause includes the following circumstances:

- (1) The listed DBE subcontractor fails or refuses to execute a written contract;
- (2) The listed DBE subcontractor fails or refuses to perform the work of its subcontract in a way consistent with normal industry standards. Provided, however, that good cause does not exist if the failure or refusal of the DBE subcontractor to perform its work on the subcontract results from the bad faith or discriminatory action of the prime contractor;
- (3) The listed DBE subcontractor fails or refuses to meet the prime Contractor's reasonable, nondiscriminatory bond requirements;
- (4) The listed DBE subcontractor becomes bankrupt, insolvent, or exhibits credit unworthiness;
- (5) The listed DBE subcontractor is ineligible to work on public works projects because of suspension and debarment proceedings pursuant to CFR Parts 180, 215 and 1200 or applicable state law.
- (6) You have determined that the listed DBE subcontractor is not a responsible contractor;
- (7) The listed DBE subcontractor voluntarily withdraws from the projects and provides to you written notice of its withdrawal;
- (8) The listed DBE is ineligible to receive DBE credit for the type of work required;
- (9) A DBE owner dies or becomes disabled with the result that the listed DBE subcontractor is unable to complete its work on the contract;
- (10) Other documented good cause that compels the termination of the DBE subcontractor. Provided, that good cause does not exist if the prime Contractor seeks to terminate a DBE it relied upon to obtain the contract so that the prime Contractor can self-perform the work for which the DBE contractor was engaged or so that the prime Contractor can substitute another DBE or non-DBE contractor after contract award.

When a DBE is terminated, or fails to complete its work on the Contract for any reason the Contractor shall make a good faith effort to find another DBE to substitute for the original DBE to perform at least the same amount of work under the contract as the terminated DBE to the extent needed to meet the established Contract goal. The good faith efforts shall be documented by the Contractor. If the Department requests documentation under this provision, the Contractor shall submit the documentation within seven days, which may be extended for an additional seven days if necessary at the request of the Contractor. The Department shall provide a written determination to the Contractor stating whether or not good faith efforts have been demonstrated.

(f) **FINAL PAYMENT.** After the performance of the final item of work or delivery of material by a DBE and final payment therefore to the DBE by the Contractor, but not later than thirty calendar days after payment has been made by the Department to the Contractor for such work or material, the Contractor shall submit a DBE Payment Agreement on Department form SBE 2115 to the Resident Engineer. If full and final payment has not been made to the DBE, the DBE Payment Agreement shall indicate whether a disagreement as to the payment required exists between the Contractor and the DBE or if the Contractor believes that the work has not been satisfactorily completed. If the Contractor does not have the full amount of work indicated in the Utilization Plan performed by the DBE companies indicated in the Utilization Plan and after good faith efforts are reviewed, the Department may deduct from contract payments to the Contractor the amount of the goal not achieved as liquidated and ascertained damages. The Contractor may request an administrative reconsideration of any amount deducted as damages pursuant to subsection (h) of this part.

(g) **ENFORCEMENT.** The Department reserves the right to withhold payment to the Contractor to enforce the provisions of this Special Provision. Final payment shall not be made on the contract until such time as the Contractor submits sufficient documentation demonstrating achievement of the goal in accordance with this Special Provision or after liquidated damages have been determined and collected.

(h) **RECONSIDERATION.** Notwithstanding any other provision of the contract, including but not limited to Article 109.09 of the Standard Specifications, the Contractor may request administrative reconsideration of a decision to deduct the amount of the goal not achieved as liquidated damages. A request to reconsider shall be delivered to the Contract Compliance Section and shall be handled and considered in the same manner as set forth in paragraph (c) of "Good Faith Effort Procedures" of this Special Provision, except a final decision that a good faith effort was not made during contract performance to achieve the goal agreed to in the Utilization Plan shall be the final administrative decision of the Department. The result of the reconsideration process is not administratively appealable to the U.S. Department of Transportation.

SPECIAL PROVISION FOR WEEKLY DBE TRUCKING REPORTS (BDE)

Effective: June 2, 2012

Revised: April 2, 2015

The Contractor shall submit a weekly report of Disadvantaged Business Enterprise (DBE) trucks hired by the Contractor or subcontractors (i.e. not owned by the Contractor or subcontractors) that are used for DBE goal credit.

The report shall be submitted to the Resident Engineer on Division of Aeronautics Form "AER 723" within ten business days following the reporting period. The reporting period shall be Monday through Sunday for each week reportable trucking activities occur.

Any costs associated with providing weekly DBE trucking reports shall be considered as included in the contract unit prices bid for the various items of work involved and no additional compensation will be allowed.

SPECIAL PROVISION FOR SUBCONTRACTOR MOBILIZATION PAYMENTS

Effective: November 2, 2017

To account for the preparatory work and the operations necessary for the movement of subcontractor personnel, equipment, supplies, and incidentals to the project site and for all other work or operations that must be performed or costs incurred when beginning work approved for subcontracting according to Section 80-01 of the Standard Specifications, the Contractor shall make a mobilization payment to each subcontractor.

This mobilization payment shall be made at least 14 days prior to the subcontractor starting work. The amount paid shall be at the following percentage of the amount of the subcontract reported on form AER 260A submitted for the approval of the subcontractor's work.

Value of Subcontract Reported on Form AER 260A	Mobilization Percentage
Less than \$10,000	25%
\$10,000 to less than \$20,000	20%
\$20,000 to less than \$40,000	18%
\$40,000 to less than \$60,000	16%
\$60,000 to less than \$80,000	14%
\$80,000 to less than \$100,000	12%
\$100,000 to less than \$250,000	10%
\$250,000 to less than \$500,000	9%
\$500,000 to \$750,000	8%
Over \$750,000	7%

The mobilization payment to the subcontractor is an advance payment of the reported amount of the subcontract and is not a payment in addition to the amount of the subcontract; therefore, the amount of the advance payment will be deducted from future progress payments.

This provision shall be incorporated directly or by reference into each subcontract approved by the Department.

SPECIAL PROVISION FOR PAYMENTS TO SUBCONTRACTORS

Effective: November 2, 2017

Federal regulations found at 49 CFR §26.29 mandate the Department to establish a contract clause to require Contractors to pay subcontractors for satisfactory performance of their subcontracts and to set the time for such payments.

State law also addresses the timing of payments to be made to subcontractors and material suppliers. Section 7 of the Prompt Payment Act, 30 ILCS 540/7, requires that when a Contractor receives any payment from the Department, the Contractor shall make corresponding, proportional payments to each subcontractor and material supplier performing work or supplying material within 15 calendar days after receipt of the Department payment. Section 7 of the Act further provides that interest in the amount of two percent per month, in addition to the payment due, shall be paid to any subcontractor or material supplier by the Contractor if the payment required by the Act is withheld or delayed without reasonable cause. The Act also provides that the time for payment required and the calculation of any interest due applies to transactions between subcontractors and lower-tier subcontractors and material suppliers throughout the contracting chain.

This Special Provision establishes the required federal contract clause, and adopts the 15 calendar day requirement of the State Prompt Payment Act for purposes of compliance with the federal regulation regarding payments to subcontractors. This contract is subject to the following payment obligations.

When progress payments are made to the Contractor according to Article 90-07 of the Standard Specifications, the Contractor shall make a corresponding payment to each subcontractor and material supplier in proportion to the work satisfactorily completed by each subcontractor and for the material supplied to perform any work of the contract. The proportionate amount of partial payment due to each subcontractor and material supplier throughout the contracting chain shall be determined by the quantities measured or otherwise determined as eligible for payment by the Department and included in the progress payment to the Contractor. Subcontractors and material suppliers shall be paid by the Contractor within 15 calendar days after the receipt of payment from the Department. The Contractor shall not hold retainage from the subcontractors. These obligations shall also apply to any payments made by subcontractors and material suppliers to their subcontractors and material suppliers; and to all payments made to lower tier subcontractors and material suppliers throughout the contracting chain. Any payment or portion of a payment subject to this provision may only be withheld from the subcontractor or material supplier to whom it is due for reasonable cause. If reasonable cause is asserted, written notice shall be provided to the applicable subcontractor and/or material supplier and the Engineer within five days of the Contractor receiving payment. The written notice shall identify the contract number, the subcontract or material purchase agreement, a detailed reason for refusal, the value of payment being withheld, and the specific remedial actions required of the subcontractor and/or material supplier so that payment can be made.

This Special Provision does not create any rights in favor of any subcontractor or material supplier against the State or authorize any cause of action against the State on account of any payment, nonpayment, delayed payment, or interest claimed by application of the State Prompt Payment Act. The Department will not approve any delay or postponement of the 15 day requirement except for reasonable cause shown after notice and hearing pursuant to Section 7(b) of the State Prompt Payment Act. State law creates other and additional remedies available to any subcontractor or material supplier, regardless of tier, who has not been paid for work properly performed or material furnished. These remedies are a lien against public funds set forth in Section 23(c) of the Mechanics Lien Act, 770 ILCS 60/23(c), and a recovery on the Contractor's payment bond according to the Public Construction Bond Act, 30 ILCS 550.

SPECIAL PROVISION FOR SUBCONTRACTOR AND DBE PAYMENT REPORTING (BDE)
Effective: April 2, 2018

Subcontractor and Disadvantaged Business Enterprise Payment Reporting

The Contractor shall report all payments made to the following parties:

- (a) first tier subcontractors;
- (b) lower tier subcontractors affecting disadvantaged business enterprise (DBE) goal credit;
- (c) material suppliers or trucking firms that are part of the Contractor's submitted DBE utilization plan.

The report shall be made through the Department's on-line subcontractor payment reporting system within 21 days of making the payment.

SPECIAL PROVISION FOR NPDES CERTIFICATION

In accordance with the provisions of the Illinois Environmental Protection Act, the Illinois Pollution Control Board Rules and Regulations (35 Ill. Adm. Code, Subtitle C, Chapter I), and the Clean Water Act, and the regulations thereunder, this certification is required for all construction contracts that will result in the disturbance of one or more acres total land area.

The bidder certifies under penalty of law that he/she understands the terms and conditions of the general National Pollutant Discharge Elimination System (NPDES) permit (ILR100000) that authorizes the storm water discharges associated with industrial activity from the construction site identified as part of this certification.

The Airport Owner or its Agent will:

- 1) prepare, sign and submit the Notice of Intent (NOI)
- 2) conduct site inspections and complete and file the inspection reports
- 3) submit Incidence of Non-Compliance (ION) forms
- 4) submit Notice of Termination (NOT) form

Prior to the issuance of the Notice-to-Proceed, for each erosion control measure identified in the Storm Water Pollution Prevention Plan, the contractor or subcontractor responsible for the control measure(s) must sign the above certification (forms to be provided by the Department).

REVISIONS TO THE ILLINOIS PREVAILING WAGE RATES

The Prevailing rates of wages are included in this Contract proposal. The rates have been ascertained and certified by the Illinois Department of Labor for the locality in which the work is to be performed and for each craft or type of work or mechanic needed to execute the work of the Contract. As required by Prevailing Wage Act ([820 ILCS](#) 130/0.01, et seq.) and this Proposal, not less than the rates of wages ascertained by the Illinois Department of Labor and as revised during the performance of a Contract shall be paid to all laborers, workers and mechanics performing work under the Contract. Post the scale of wages in a prominent and easily accessible place at the site of work.

If the Illinois Department of Labor revises the prevailing rates of wages to be paid as listed in the specification of rates, the contractor shall post the revised rates of wages and shall pay not less than the revised rates of wages. Current wage rate information shall be obtained by visiting the Illinois Department of Labor web site at <http://www.state.il.us/agency/idol/> or by calling 312-793-2814. It is the responsibility of the contractor to review the rates applicable to the work of the contract at regular intervals in order to insure the timely payment of current rates. Provision of this information to the contractor by means of the Illinois Department of Labor web site satisfies the notification of revisions by the Department to the contractor pursuant to the Act, and the contractor agrees that no additional notice is required. The contractor shall notify each of its subcontractors of the revised rates of wages.

SECTION III

Special Provisions

For

REHABILITATE TERMINAL ENTRANCE ROAD AND AUTO PARKING LOT

ILLINOIS PROJECT: 06C-4649

at

SCHAUMBURG REGIONAL AIRPORT
SCHAUMBURG, ILLINOIS



November 16, 2018

Prepared By:

CRAWFORD, MURPHY & TILLY, INC.
CONSULTING ENGINEERS
550 North Commons Drive, Suite 116
Aurora, Illinois 60504
<http://www.cmtengr.com>



18256-02-00

GENERAL

These Special Provisions, together with applicable Standard Specifications, Rules and Regulations, Contract Requirements for Airport Improvement Projects, Payroll Requirements and Minimum Wage Rates which are hereto attached or which by reference are herein incorporated, cover the requirements of the State of Illinois, Department of Transportation, Division of Aeronautics for the construction of the subject project at the Schaumburg Regional Airport, Schaumburg, Illinois.

GOVERNING SPECIFICATIONS AND RULES AND REGULATIONS

The “Illinois Standard Specifications for Construction of Airports”, dated April 1, 2012, State of Illinois Department of Transportation, Division of Aeronautics shall govern the project except as otherwise noted in these Special Provisions. In cases of conflict with any part or parts of said specifications, the said Special Provisions shall take precedence and shall govern. When noted within the Special Provisions, the Illinois Department of Transportation “Standard Specifications for Road and Bridge Construction”, Adopted April 1, 2016, shall also apply along with the IDOT Supplemental Specifications and Recurring Special Provisions, Adopted January 1, 2018.

The “Illinois Standard Specifications for Construction of Airports” dated April 1, 2012 can be obtained from the Illinois Department of Transportation, Division of Aeronautics website at <http://www.idot.illinois.gov/doing-business/procurements/construction-services/contractors-resources/index> or from the Division of Aeronautics.

INDEX TO SPECIAL PROVISIONS

ITEM – DESCRIPTION	PAGE NUMBER
DIVISION I – GENERAL PROVISIONS	1
SECTION 40 – Scope of Work	1
SECTION 50 – Control Of Work	3
SECTION 60 – Control Of Materials	5
SECTION 70 – Legal Relations And Responsibility To Public	6
SECTION 80 – Prosecution And Progress	8
SECTION 90 – Measurement And Payment	9
DIVISION II – PAVING CONSTRUCTION DETAILS	10
ITEM 150520 – Mobilization	10
ITEM 152540 – Soil Stabilization Fabric	11
ITEM 208 – Aggregate Base Course	13
ITEM 401 – Bituminous Surface Course Superpave (Method I).....	16
ITEM 401650 – Bituminous Pavement Milling	18
ITEM 401916 – Remove and Replace HMA Pavement – Type B	19
ITEM 501 – Portland Cement Concrete Pavement	22
ITEM AR501900 – Remove PCC Pavement	26
ITEM 602 - Bituminous Prime Coat	27
ITEM 603 – Bituminous Tack Coat	28
ITEM 620 – Pavement Marking	29
ITEM 754 – Concrete Gutters, Ditches And Flumes.....	31

DIVISION VIII – MISCELLANEOUS	32
ITEM 910 – Roadway Signage	32
APPENDIX A - IDOT DIVISION OF AERONAUTICS POLICY MEMORANDA	A
APPENDIX B - IDOT DESIGN STANDARDS	B

POLICY MEMORANDA – APPENDIX A INDEX

87-4	DETERMINATION OF BULK SPECIFIC GRAVITY (d) OF COMPACTED BITUMINOUS MIXES
96-1	ITEM 610, STRUCTURAL PORTLAND CEMENT CONCRETE: JOB MIX FORMULA APPROVAL & PRODUCTION TESTING
96-3	REQUIREMENTS FOR QUALITY ASSURANCE ON PROJECTS WITH BITUMINOUS CONCRETE PAVING
97-2	PAVEMENT MARKING PAINT ACCEPTANCE
2003-1	REQUIREMENTS FOR LABORATORY, TESTING, QUALITY CONTROL, AND PAVING OF SUPERPAVE BITUMINOUS CONCRETE MIXTURES FOR AIRPORTS

IDOT DESIGN STANDARDS – APPENDIX B INDEX

606001-07	CONCRETE CURB TYPE B AND COMBINATION CONCRETE CURB AND GUTTER
720001-01	SIGN PANEL MOUNTING DETAILS
720006-04	SIGN PANEL ERECTION DETAILS
720011-01	METAL POSTS FOR SIGNS, MARKERS & DELINEATORS

DIVISION I – GENERAL PROVISIONS

SECTION 40 – SCOPE OF WORK

40-05 MAINTENANCE OF TRAFFIC

ADD:

The Contractor shall be responsible for cleaning and maintaining all haul roads and use a pick-up type sweeper on all pavements and adjacent roadways utilized in hauling operations when material is tracked onto said pavement. **The Contractor shall have a sweeper on site and maintain all pavements clear of dirt and debris at all times or as requested by the Resident Engineer.** If the Contractor fails to comply with the Standard Specifications, Contract Plans or these Special Provisions concerning traffic control, the Resident Engineer shall execute such work as may be deemed necessary to correct deficiencies and the cost thereof shall be deducted from compensation due or which may become due the Contractor under the contract. The Contractor shall be responsible for supplying, maintaining and moving all barricades required for construction. The cost thereof shall not be paid for separately but shall be considered incidental to the contract unit prices.

40-09 AIRPORT OPERATIONS DURING CONSTRUCTION

ADD:

a. Construction Activity and Aircraft Movements

For construction activity to be performed in areas other than active operational areas, the storage and parking of equipment and materials, when not in use or about to be installed, shall not encroach upon active operational areas. In protecting operational areas, the minimum clearances maintained for runways shall be in conformance with Part 77 of the Federal Aviation Regulations.

All construction operations shall conform to the plans and in accordance with AC 150/5370-2 (Latest Edition) Operational Safety on Airports during Construction.

b. Limitations on Construction

(1) Open flame welding or torch cutting operations shall be prohibited, unless adequate fire and safety precautions are provided.

(2) Open trenches, excavations and stockpiled material near any pavements shall be prominently marked with red flags and lighted by light units during hours of restricted visibility and/or darkness.

(3) Stockpiled material shall be constrained in a manner to prevent movement resulting from aircraft blast or wind conditions.

(4) The use of explosives shall be prohibited.

(5) Burning shall not be allowed.

c. Debris

Waste and loose material capable of causing damage to aircraft landing gears, propellers, or being ingested in jet engines shall not be placed on active aircraft movement areas. Material tracked on these areas shall be removed continuously during the work. The Contractor shall provide garbage cans in employee parking areas and storage areas for debris.

SECTION 50 – CONTROL OF WORK

50-06 CONSTRUCTION LAYOUT

RESPONSIBILITY OF THE RESIDENT ENGINEER

DELETE:

Paragraphs A and B and replace with the following:

- A. The Resident Engineer will locate and reference two (2) control points within the limits of the project.
- B. A benchmark has been established along the project outside of construction lines.

ADD:

M. It is not the responsibility of the Resident Engineer to check the correctness of the Contractor's stakes or forms, except as provided herein; however, any errors that are apparent shall be immediately called to the Contractor's attention, and he shall be required to make the necessary correction before the stakes are used for construction purposes.

RESPONSIBILITY OF THE CONTRACTOR

ADD:

- H. The Contractor shall immediately notify the Resident Engineer of conflicts or discrepancies with the established control points.
- I. Construction layout shall not be paid for separately, but shall be considered incidental to the pay item for which the layout is required.

50-10 INSPECTION OF WORK

ADD:

The Contractor shall provide portable flood lighting for nighttime construction. Sufficient units shall be provided so that work areas are illuminated to a level of five horizontal foot candles. The lighting levels shall be calculated and measured in accordance with the current standards of the Illumination Engineering Society. Lights shall be positioned so as not to interfere with Airport operations.

50-12 LOAD RESTRICTIONS

ADD:

Access to the construction work area is limited to the haul routes as shown in the plans. The use of existing airfield pavements by the Contractor's construction traffic, including all haul traffic, is limited to the hauling routes shown in the plans. Use of existing airfield pavement other than as shown in the plans is prohibited. **Any damage to existing airfield pavement due to construction traffic operating within or beyond the approved work limits, hauling within or outside of the approved haul/access routes and construction traffic operating in prohibited areas shall be repaired by the Contractor at his own expense to the satisfaction of the Owner.**

Contractor shall obtain written permission from the Airport Owner to use any airfield pavements.

The Contractor shall not be allowed to use FAA access roads at any time.

50-16 FINAL INSPECTION

ADD:

All work on the punch list shall be considered part of the contract and shall be considered incidental to the completion of the contract. If the Contractor believes that an item listed on the punch list is beyond the scope of the contract, the Contractor shall notify the Engineer in writing prior to commencing work on the punch list item in question. Any punch list items completed by the Contractor without such written notification shall be considered incidental to the contract and shall not be eligible for payment unless determined otherwise by the Engineer and Owner.

50-18 PLANS AND WORK DRAWINGS

DELETE:

References to “approval” in first paragraph and replace with “review”.

REVISE the fifth paragraph to read:

Shop drawings submitted by the Contractor for materials and/or equipment to be provided as a part of the contract shall be reviewed by the Project Engineer for substantial conformance of said materials and/or equipment, to contract requirements. Shop drawings shall be fully descriptive, complete and of sufficient detail for ready determination of compliance.

REVISE the last paragraph to read:

The following information shall be clearly marked on each shop, working, and layout drawing, catalog cut, pamphlet specifications sheet, etc., submitted.

PROJECT LOCATION:	Schaumburg Regional Airport
PROJECT TITLE:	Rehabilitate Terminal Entrance Road and Auto Parking Lot
PROJECT NUMBERS:	IL Project: 06C-4649
CONTRACT ITEM:	(i.e. AR 401610 Bituminous Surface Course)
SUBMITTED BY:	(Contractor/Subcontractor Name)
DATE:	(Date Submitted)

SECTION 60 – CONTROL OF MATERIALS

60-01 SOURCE OF SUPPLY AND QUALITY REQUIREMENTS

ADD: After the last paragraph

The Contractor shall certify all materials contained in the contract. Certification documentation shall be submitted to the Engineer. It shall be the sole responsibility of the Contractor to ensure the delivery of adequate and accurate documentation prior to the delivery of the materials.

If, upon delivery and incorporation of any materials, the Contractor has failed to provide the necessary submittals as required by Sections 50-18, 60-01, 60-03 and 60-11 of the Standard Specifications and Special Provisions, the pay item shall not be included on the Construction Progress Payment report until such submittals have been furnished.

60-03 CERTIFICATION OF COMPLIANCE

ADD:

Additional requirements are specified in Section 60-11 Certification of Materials.

60-11 CERTIFICATION OF MATERIALS

ADD:

The Contractor shall certify all materials incorporated into the contract. Certification documentation shall be submitted to the Resident Engineer. It shall be the **sole** responsibility of the Contractor to ensure the submittal of adequate and accurate documentation in order to satisfy the contract material certification requirements **prior** to the delivery of the materials. Materials without certification or those with certification that demonstrates the materials do not meet the requirements of the plans and specifications shall be considered nonconforming and subject to the provisions of Section 50-02.

As a guide to the certification process and requirements, the Contractor shall use the Illinois Department of Transportation/Division of Aeronautics MANUAL FOR DOCUMENTATION OF AIRPORT MATERIALS dated April 1, 2010 or latest edition including any addendums. Copies of this manual are available by contacting Mr. Mike Wilhelm-Division of Aeronautics at (217) 785-4282 or from their website at <http://www.idot.illinois.gov/home/resources/Manuals/Manuals-and-Guides>.

The cost of providing the required material documentation and certifications shall **not** be paid for separately, but shall be considered incidental to the associated item.

SECTION 70 – LEGAL RELATIONS AND RESPONSIBILITY TO PUBLIC

70-17 CONTRACTOR'S RESPONSIBILITY FOR UTILITY SERVICE AND FACILITIES OF OTHERS

ADD:

Special care shall be taken on all operations, and particularly near pavement edges, to avoid damage to edge lights and all underground electrical cable on the airport. The approximate location of existing underground cable is shown on drawings. Any airfield lights or cable that are broken and require replacement because of the Contractor's operations will be replaced by the contractor at his own expense.

Any airfield cable repairs or replacement to any part of the electrical system made necessary by the Contractor's operations will be made by him in the manner specified in Sections 108 and 125 at no cost to the airport. Cost of replacement to be borne by the Contractor shall include any expense incurred in locating as well as repairing or replacing damaged parts of the system by the owning agency.

It shall be the Contractor's responsibility to locate and protect all airport-owned utilities within the construction limits. This includes all electrical cables, storm sewer, drain tile, sanitary sewer and water main.

Special attention is necessary when working near FAA power and control cables. Any FAA utility that is damaged or cut during construction shall be repaired immediately. FAA requires that any damaged cable be replaced in its entirety, from power/control source to the equipment/service. Splices of any kind will not be permitted. Exposures of any FAA cables must be done by hand digging or hydro-excavation. No additional compensation will be made for locating, replacement or repair of FAA facilities or cables but, shall be incidental to the contract.

When FAA cables are required to be located, or the contractor is planning on working on or around FAA cables, conduits or equipment, a 10-working day advanced notice shall be given to the FAA before any such markings are required. Once FAA marks the cables, the contractor will be required to survey the FAA utilities, so they can be replaced during construction without remarking by the FAA. This shall be incidental to the contract. The FAA personnel are only available from 9 am to 3 pm, Monday through Friday with advanced notice.

Should any utilities or cables require location, the following people shall be contacted:

<u>Utility Service or Facility</u>	<u>Contact (Person)</u>	<u>Contact (Phone)</u>
AT&T – Telephone Cables	J.U.L.I.E. (Joint Utility Locating Information for Excavators)	1-800-892-0123
ComEd - Electric Cables	J.U.L.I.E. (Joint Utility Locating Information for Excavators)	1-800-892-0123
NICOR - Gas Lines	J.U.L.I.E. (Joint Utility Locating Information for Excavators)	1-800-892-0123
FAA Control and Communication Cables	FAA Sector Office	1-630-587-7801
Sewer and Water	Village of Schaumburg – Public Works Department	1-847-895-7100

70-26 CONTRACTOR'S RESPONSIBILITY FOR SAFETY DURING CONSTRUCTION

ADD the following after Item D.:

E. Provide a safety officer/construction inspector trained in airport safety to monitor construction activities.

F. Restrict movement of construction vehicles to construction areas with flagging and barricading, erecting temporary fencing, or providing escorts, as appropriate or as shown in plans.

G. Ensure that no construction employees, employees of subcontractors or suppliers, or other persons enter any part of the aircraft operations area from construction site unless authorized.

SECTION 80 – PROSECUTION AND PROGRESS

80-03 NOTICE TO PROCEED

ADD:

The Notice to Proceed will not be given until all materials are certified by the Contractor to be available and on hand and meeting the Buy American requirements per the Contract Documents.

80-05 LIMITATION OF OPERATIONS

ADD:

The Contractor shall not have access to any part of the active airfield (runways or taxiways) for any equipment or personnel without approval of the Airport Manager. All operations shall conform to the approved construction activity plan and general notes.

80-07 TEMPORARY SUSPENSION OF THE WORK

REVISE the second paragraph to read:

In the event that the Contractor is ordered by the Engineer to suspend work for some unforeseen cause not otherwise provided for in the contract and over which the Contractor has no control, the Contractor may be reimbursed for actual money expended on the work during the period of shutdown. No allowance will be made for anticipated profits. The period of shutdown shall be computed from the effective date of the Engineer's order to suspend work to the effective date of the Engineer's order to resume the work. Claims for such compensation shall be filed with the Resident Engineer within the time period stated in the Engineer's order to resume work. The Contractor shall submit with his/her claim information substantiating the amount shown on the claim. The Resident Engineer will forward the Contractor's claim to the Division for their consideration in accordance with local laws or ordinances. No provision of this article shall be construed as entitling the Contractor to compensation for delays due to inclement weather, for suspension made at the request of the Engineer, or for any other delay provided for in the contract, plans, or specifications.

SECTION 90 – MEASUREMENT AND PAYMENT

90-05 PAYMENT FOR EXTRA AND FORCE ACCOUNT WORK

ADD the following to subsection B.7. Statements:

All statements of the cost of force account work shall be furnished to the Engineer not later than 60 days after completion of the force account work. If the statement is not received within the specified time frame, all demands for payment for the extra work are waived and the Division, Airport Owner and Local Sponsor are released from any and all such demands. It is the responsibility of the Contractor to ensure that all statements are received within the specified time regardless of the manner or method of delivery.

DIVISION II – PAVING CONSTRUCTION DETAILS

ITEM 150520 – MOBILIZATION

BASIS OF PAYMENT

150-3.1

REVISE:

Paragraph (C) to the following:

- C. When fifty percent of the original contract is earned, an additional 20 percent of the pay item will be paid.

ADD:

- D. When 90 percent of the adjusted contract value is earned, an additional 15 percent of the pay item will be paid along with any bid amount in excess of six percent of the original contract amount up to 95% of the pay item.

- E. The remaining 5 percent of the pay item will be paid upon final acceptance of the project by the Engineer. Final acceptance includes satisfactory completion of all punch list items in accordance with written instruction from the engineer as well as acceptance of all final documentation.

Payment will be made under:

ITEM AR150520 MOBILIZATION – PER LUMP SUM.

ITEM 152540 – SOIL STABILIZATION FABRIC

DESCRIPTION

152-1.1

ADD:

This item shall also consist of soil stabilization fabric for subgrade remediation as the field conditions warrant at the time of construction. This material is intended to repair soft subgrade as determined by the Resident Engineer based on the results of geotechnical testing and/or proof roll. No adjustment in unit price will be allowed for an increase or decrease in quantities.

CONSTRUCTION METHODS

152-3.1

ADD:

Soil Stabilization Fabric shall be delivered to the jobsite in such a manner as to facilitate handling and incorporation into the work without damage. Material shall be stored in such a manner as to prevent exposure to direct sunlight and damage by other construction activities.

152-3.2

ADD:

Prior to the installation of the soil stabilization fabric, the application surface shall be cleared of debris and sharp objects. In the case of subgrades, all wheel tracks or ruts in excess of 75 mm (3 inches) in depth shall be graded smooth or otherwise filled with soil to provide a reasonably smooth surface. Soil stabilization fabric may be installed on the application surface either by hand or by mechanical methods, provided that the fabric is not torn or the surface rutted.

152-3.3

ADD:

Soil stabilization fabric of insufficient width or length to fully cover the specified area shall be lapped, or sewn. The minimum laps for lap only areas are 600 mm (24 inches) and for sewn areas are 100 mm (4 inches). If sewn, the seam strength shall be equal to or exceed the minimum grab tensile strength of the fabric when tested wet.

152-3.4

ADD:

The crushed aggregate subbase shall be constructed to the width and depth required on the plans. The material shall be back dumped on the fabric in a sequence of operations beginning at the outer edges of the treatment area with subsequent placement towards the middle. Placement of material on the soil stabilization fabric shall be accomplished by spreading dumped material off of previously placed material with a bulldozer blade or endloader, in such a manner as to prevent tearing or shoving of the fabric. Dumping of material directly on the fabric will only be permitted to establish an initial working platform. No vehicles or construction equipment shall be allowed on the fabric prior to

placement of the crushed aggregate subbase. The granular material shall be placed to the full required thickness and compacted to the satisfaction of the Resident Engineer before any loaded trucks are allowed on the area covered.

152-3.5

ADD:

Soil stabilization fabric which is damaged during installation or subsequent placement of granular material due to failure of the Contractor to comply with these provisions, shall be repaired or replaced at the Contractor's expense, including costs of removal and replacement of the granular material. Torn fabric may be patched in place by cutting and placing a piece of the same fabric over the tear. The dimensions of the patch shall be at least 600 mm (2 ft.) larger than the tear in each direction, and shall be weighted or otherwise secured to prevent the granular material from causing lap separation.

BASIS OF PAYMENT

152-5.1

ADD:

Payment will be made under:

ITEM AR152540 SOIL STABILIZATION FABRIC – PER SQUARE YARD.

ITEM 208 – AGGREGATE BASE COURSE

DESCRIPTION

208-1.1

ADD:

This item shall consist of the removal of existing aggregate base and replacement with coarse aggregate as specified herein. It shall be constructed on a prepared underlying subgrade in accordance with these specifications and shall conform to the dimensions and typical cross section and to the lines and grades as shown on the Plans.

This work shall also consist of removing soft and/or yielding subgrade and furnishing and placing porous granular embankment as the field conditions warrant at the time of construction. This material is intended to repair soft subgrade as determined by the Resident Engineer based on results of geotechnical testing, proof roll and/or visual observations. No adjustment in unit price will be allowed for an increase or decrease in quantities.

MATERIALS

208-2.1 UNCRUSHED COARSE AGGREGATE

DELETE: This Entire Section.

208-2.2 CRUSHED COARSE AGGREGATE

DELETE: Paragraph C.

208-2.3 GRADATION

ADD:

The material shall be free from vegetable matter, lumps or clay, and other objectionable or foreign substance.

When submitting materials for consideration, the Contractor shall provide written certification that the material meets the specified requirements. A written gradation shall also be furnished.

Gradation for the aggregate base course replacement shall be IDOT CA-6, CM-6 or CA-10.

Gradation for Porous Granular Embankment shall be as follows:

Sieve	Percent Passing
4 inch	-
3 inch	100
2 inch	-
1 ½ inch	76-30
NO. 4	16-0
IDOT Gradation	RR-1

CONSTRUCTION REQUIREMENTS

208-3.2 PREPARING UNDERLYING COURSE

DELETE: This Entire Section.

208-3.3 METHODS OF PRODUCTION

DELETE: This Entire Section.

208-3.4 PLACING

DELETE: This Entire Section.

ADD:

The porous granular embankment shall be placed in lifts no greater than one (1) foot thick or as directed by the Resident Engineer.

208-3.5 FINISHING AND COMPACTING

ADD:

The Contractor shall submit copies of all density test results for each lift to the Resident Engineer prior to acceptance testing.

DELETE: Fifth sentence, first paragraph.

ADD:

For Porous Granular Embankment

Rolling the top of the aggregate material with a vibratory roller meeting the requirements of Section 1101 of the IDOT *Standard Specification for Road and Bridge Construction* should be sufficient to obtain the desired keying or interlock and necessary compaction. The Resident Engineer shall verify that adequate keying has been obtained. The base shall be compacted to the satisfaction of the Resident Engineer.

Capping aggregate will not be required when embankment meeting the requirements of Section 208 of the Standard Specifications or granular subbase is placed on top of the porous granular embankment. Capping aggregate (two (2) inch depth) meeting the requirements of Section 208 of the Standard Specifications will be required when embankment meeting the requirements of Section 152 of the Standard Specifications is placed on top of the porous granular embankment.

For Aggregate Base Course Replacement

Rolling shall continue until the base material has been compacted to a density of not less than 100% of the maximum density, at optimum moisture in accordance with ASTM D 698 (Standard Proctor)

DELETE: Second paragraph.

DELETE: Second sentence, third paragraph and REPLACE with:

When the rolling develops irregularities that exceed 3/8 inch when tested using an acceptable method, the irregular surface shall be loosened, refilled with the same kind of material as that used in constructing the course, and rolled again as required.

METHOD OF MEASUREMENT

208-4.1

DELETE: This Entire Section.

208-4.2

ADD:

The quantity of Porous Granular Embankment shall be the number of cubic yards as measured by the Engineer at the specified thickness of the material placed. If required, the thickness of PGE measured for payment will include the thickness of the capping stone.

The porous granular embankment shall be used as shown and as field conditions warrant at the time of construction. No adjustment in unit price will be allowed for an increase or decrease in quantities.

The Contractor shall furnish approved duplicate load tickets upon which the net weight of the aggregates in each truck is recorded. The Contractor shall submit one (1) load ticket to the Resident Engineer, or his/her duly authorized representative, at the job site when the truck load is incorporated into the base.

208-4.3

DELETE: This Entire Section.

BASIS OF PAYMENT

208-5.1

DELETE: Entire Section.

ADD:

Porous granular embankment shall be paid for at the contract unit price per cubic yard, of which price shall be full compensation for all required excavation, the porous granular embankment material and two (2) inch capping stone (if necessary), furnishing, spreading, compacting, watering and all incidentals related to equipment, labor and tools necessary to complete this work.

The aggregate base course replacement shall be paid for at the contract unit price per square yard, of which shall be full compensation for all required excavation, aggregate furnishing, spreading, compacting, watering new aggregate base material and all incidentals related to equipment, labor and tools necessary to complete this work.

Repair and preparation of existing aggregate base course and/or subgrade and proof rolling shall not be paid for separately but shall be considered incidental to the contract.

Payment will be made under:

**ITEM AR208515 POROUS GRANULAR EMBANKMENT – PER CUBIC YARD.
ITEM AR208910 REMOVE & REPLACE AGGREGATE BASE – PER SQUARE YARD.**

ITEM 401 – BITUMINOUS SURFACE COURSE SUPERPAVE (METHOD I)

(CENTRAL PLANT HOT MIX)

DESCRIPTION

401-1.1

ADD: The following after the third paragraph of this section:

This project shall utilize Method I for the production, placement and acceptance of the bituminous surface course.

At the Contractor's option, an IDOT Division of Highways surface mix may be submitted for approval by the Engineer. The surface mix shall be in accordance with Section 406 Hot-Mix Asphalt Binder and Surface Course of the Illinois Department of Transportation "Standard Specifications for Road and Bridge Construction". The mix shall be a production mix from the current construction season meeting Mixture Composition:

HOT-MIX ASPHALT SURFACE COURSE, MIX "D", N50, MIX TYPE IL-9.5 mm.

COMPOSITION

401-3.2 JOB MIX FORMULA

ADD: The following after the third paragraph of this section:

Table 1 Superpave Design Criteria for Automobile, Entrance Roads and Parking Lots shall apply.

CONSTRUCTION METHODS

401-4.12 JOINTS

ADD: The following as the sixth paragraph of this section:

If at any time during the surface course paving operation, it becomes necessary to end a paving lane at a location other than the new finished pavement edge because of ending a day's paving, machinery breakdown, etc., the lane end will be sawed back a sufficient distance to provide a smooth, neat appearing joint from which to resume paving. The sawed face will be painted with a tack coat and this work shall be considered incidental to Item 401, Bituminous Surface Course, and no additional compensation will be allowed.

401-4.14 SHAPING EDGES

ADD: The following as the second paragraph for this section:

All pavement edges, including the pavement ends, must be left in proper alignment, as shown on the plans. This may be accomplished by a trimming method, or, at the Contractor's option, by sawing after the paving has been completed. No additional compensation will be made if the sawing method is used.

401-4.15 ACCEPTANCE TESTING OF HMA MIXES FOR DENSITY

DELETE: All references to Method II for quantities over 2,500 tons.

BASIS OF PAYMENT

401-6.1

Payment will be made under:

ITEM AR401610 BITUMINOUS SURFACE COURSE - PER TON.

ITEM 401650 – BITUMINOUS PAVEMENT MILLING

DESCRIPTION

401-1.1

ADD:

The material removed shall be disposed of off airport property at no additional cost to the contract.

The Contractor shall set his milling depth appropriately to provide for no more than the proposed thickness of new bituminous surface course to be placed on the milled surface. Additional bituminous surface course required to fill improperly milled pavement shall not be paid for and the additional costs shall be borne by the Contractor. No extra compensation will be allowed for any variation in the pavement milling depths actually encountered.

CONSTRUCTION METHODS

401-3.1

ADD:

The existing pavement areas to be milled shall be milled in such a manner as to prevent damage to the adjacent structures and pavement. All edges adjacent to existing pavements shall be saw-cut full depth of the removal depth prior to removal as directed by the Engineer.

At the completion of milling and prior to paving, the Contractor shall provide to the Resident Engineer a survey of the milled surface and the required fill depths to the proposed final top of pavement.

BASIS OF PAYMENT

401-5.1

ADD:

Payment will be made under:

ITEM AR401650 BITUMINOUS PAVEMENT MILLING - PER SQUARE YARD.

ITEM 401916 – REMOVE AND REPLACE HMA PAVEMENT – TYPE B

DESCRIPTION

401916-1.1

This item shall consist of bituminous pavement removal and replacement for patches as described in the plans. Pavement removal and replacement quantities are estimated. The Resident Engineer shall lay out pavement removal and replacement areas in the field during construction. No adjustment in unit price will be allowed for an increase or decrease in quantities. The pavement shall be compacted in accordance with these specifications and shall conform to the lines, grades, thicknesses and typical sections as shown on the plans or as directed by the Resident Engineer.

Each course shall be constructed to the depth, section or elevation required as specified herein and shall be rolled, finished and approved prior to the placement of the next course.

MATERIALS

401916-2.1 BITUMINOUS SURFACE COURSE

Bituminous surface course shall be per Section 401 or at the Contractor's option, an IDOT Division of Highways surface mix may be submitted for approval by the Engineer. The surface mix shall be in accordance with Section 406 Hot-Mix Asphalt Binder and Surface Course of the Illinois Department of Transportation "Standard Specifications for Road and Bridge Construction". The mix shall be a production mix from the current construction season meeting Mixture Composition:

HOT-MIX ASPHALT SURFACE COURSE, MIX "D", N50, MIX TYPE IL-9.5 mm

401916-2.2 BITUMINOUS BASE COURSE

Bituminous base course shall be per Section 403 or at the Contractor's option, an IDOT Division of Highways surface mix may be submitted for approval by the Engineer. The surface mix shall be in accordance with Section 406 Hot-Mix Asphalt Binder and Surface Course of the Illinois Department of Transportation "Standard Specifications for Road and Bridge Construction". The mix shall be a production mix from the current construction season meeting Mixture Composition:

HOT-MIX ASPHALT BINDER COURSE, IL-19.0, N50

401916-2.3 BITUMINOUS TACK COAT

The bituminous tack coat shall conform to the specifications of Section 603.

CONSTRUCTION METHODS

401916-3.1

The type of material to be removed along with approximate typical pavement section is shown on the plans and as follows:

TYPE B – Full Depth: 3" depth bituminous surface course placed on 4" (minimum) depth bituminous base course (2-2" lifts or as approved by the Engineer)

The type of material to be removed along with approximate typical pavement section is shown on the plans. Pavement structure information was taken from airport records, data supplied by airport personnel and pavement cores. The Contractor shall verify the type and thickness of material to be removed. **No extra compensation will be allowed for any variations in the pavement sections actually encountered.**

401916-3.2

The proposed pavement replacement section shall be as specified herein. Tack coat shall be applied between each lift of asphalt and on all vertical faces of the patch area.

401916-3.3

The existing pavement areas to be removed shall be done in such a manner as to prevent damage to the adjacent pavements. All edges adjacent to existing pavements shall be saw-cut full depth prior to removal, as directed by the Resident Engineer.

Any damage to the pavement beyond the limits as shown on the plans or as directed by the Resident Engineer shall be removed and replaced by the Contractor at his expense. These areas shall be saw cut to a uniform width.

401916-3.4

Pavement replacement will be as detailed on the plans and constructed in accordance to the applicable Sections 401, 403 and 603. The various materials required for pavement replacement shall be in accordance with the applicable portions of the Standard Specifications and these Special Provisions. Any damage to pavement beyond the limits as shown on the plans **shall be removed and replaced by the Contractor at his expense. These areas shall be saw cut to a uniform width.**

401916-3.5

Pavement Removal and Replacement shall be the removal of the existing pavements as shown on the plans or as directed by the Resident Engineer and the replacement pavement as specified herein. The replacement pavement shall consist of bituminous surface course and bituminous base course conforming to the specifications of Section 401 and 403. The maximum lift thickness shall be 3". For patching, the existing aggregate base course shall be re-graded and compacted prior to the placement of the bituminous course. Cost of regrading and compacting to the existing base shall be incidental to the pavement removal and replacement.

401916-3.6

The existing pavement that is removed shall be disposed of off Airport property. No additional compensation will be made for hauling and disposal of any of the removed material.

401916-3.7 ACCEPTANCE TESTING OF HMA MIXES FOR DENSITY.

After the completion of compaction, the pavement will be tested for acceptance by the Resident Engineer and accepted on the basis of percent air voids in the final compacted mat. The HMA course shall be compacted to a minimum density of 93 percent (7 percent air voids) and a maximum of 99 percent (1 percent air voids) of the Maximum Theoretical Specific Gravity (ASTM D 2041). If, during construction, the density test falls below 93 percent, additional approved rollers shall be required. Failure to achieve density within these limits shall be cause for rejection of the material, as determined by the Division of Aeronautics.

One random nuclear density test shall be taken for each 250 tons of mix placed. Each nuclear density test shall be the average of five (5) nuclear tests taken as a cross-section of the pavement. The Resident Engineer shall have a nuclear gauge and qualified operator on the project when constructing this item for acceptance testing. The contractor shall have their own nuclear gauge and qualified operator onsite for quality control.

METHOD OF MEASUREMENT

401916-4.1

The area of pavement removal and replacement shall be measured by the number of square yards, satisfactorily removed, replaced and disposed of as shown on the plans or as directed by the Resident Engineer.

401916-4.2

If additional pavement or subgrade material is removed due to negligence on the part of the Contractor, the additional quantity of pavement removal and replacement of subgrade material will not be measured for payment.

401916-4.3

The pavement removals, bituminous surface course, bituminous base course and bituminous tack coat will not be measured separately for payment but will be considered incidental to REM & REP BIT PAVEMENT – TYPE B, per square yard.

BASIS OF PAYMENT

401916-5.1

Payment for REM & REP BIT PAVEMENT – TYPE B shall be made at the contract unit price per square yard. This price shall include full compensation for sawing, removal, disposal, replacement of asphalt materials, compaction, tack coat, including furnishing all materials, labor, tools, testing, equipment and incidentals necessary to complete this item of work.

Any grading and recompacting of existing granular base course to proper grade shall not be paid for separately but shall be considered incidental to REM & REP BIT PAVEMENT – TYPE B.

Payment will be made under:

ITEM AR401916 REM & REP BIT PAVEMENT – TYPE B – PER SQUARE YARD

ITEM 501 – PORTLAND CEMENT CONCRETE PAVEMENT

DESCRIPTION

501-1.1

This work shall also include the construction of plain Portland cement concrete sidewalk with 4-inch aggregate base course.

MATERIALS

501-2.1 through 2.11

DELETE: These sections. PCC concrete shall meet the material requirements of Section 610. Liquid membrane forming compounds for curing concrete in accordance with ASTM C 309 shall be used.

501-2.12 EPOXY MATERIAL FOR SPALL REPAIR

ADD:

The material used for the spall repair shall be a two component epoxy based bonding system for application to Portland Cement Concrete. The bonding system shall be furnished in two components for combining immediately prior to use in accordance with written instructions formulated Component A shall contain an epoxy resin with or without a reactive diluent. Component B shall contain one or more curing agents, which on mixing with Component A shall cause the mixture to harden. The color should match the existing concrete steps as close as possible.

CONSTRUCTION METHODS

501-3.1 through 3.19

DELETE: These sections. PCC concrete shall meet the construction method requirements of Section 610.

501-3.1(F) Slip Form Pavers

DELETE: This Section.

501-3.1(G) Drilling Machine

DELETE: This Section.

501-3.3(F) CONDITIONING OF UNDERLYING COURSE< SLIP FORM CONSTRUCTION

DELETE: This Section.

501-3.4 CONDITIONING OF UNDERLYING COURSE, SIDE-FORM CONSTRUCTION

ADD:

All areas shall be constructed true to grade and acceptable to the Engineer prior to paving.

During placement of the concrete pavement, the subbase shall be maintained in a moist condition without accumulation of pools of water.

In the event that the underlying course has become over-saturated or unstable, paving operations shall stop until corrected unless otherwise approved by the Engineer.

501-3.6(A) PROPORTIONS

REVISE: This Section to the following:

An Illinois Department of Transportation "Standard Specifications for Road and Bridge Construction" Section 420 Portland Cement Concrete Class PV concrete generated by the IDOT Division of Highways with recent substantiating test and strength data shall be submitted by the Contractor for approval by the Engineer in accordance with Aeronautics Policy Memorandum 96-1. The Class PV concrete shall be designed for 14-day compressive strength of 3500 psi in accordance with ASTM C 39.

The air content by volume shall be between 5% and 8% by volume, based on measurements made on concrete immediately discharged from the mixer in accordance with ASTM C 138 or C231.

The concrete shall have a minimum slump of one (1) inch and maximum slump of three (3) inches when tested in accordance with ASTM C143.

Test batch is not required.

501-3.6(B) PROPORTIONS

DELETE: This Section.

501-3.7 FIELD TEST SPECIMENS

REVISE: This Section to the following:

The Resident Engineer shall obtain field samples for acceptance testing in accordance with Aeronautics Policy Memorandum 96-1.

501-3.14 SURFACE TEXTURE

ADD:

The surface of the pavement shall be finished with a burlap drag or other approved method acceptable to the Engineer.

501-3.17 SURFACE TEST

DELETE, This Section.

501-3.17 CURING

(a) **Impervious Membrane Method** shall be utilized for this project.

501-3.22 SURFACE TOLERANCES

DELETE: Paragraphs A. and C.

501-3.23 QUALITY CONTROL PLAN

DELETE: This Section.

501-3.20 PROTECTION OF PAVEMENT AGAINST RAIN

REVISE: This Section to read:

In order that the concrete may be properly protected against the effects of rain before the concrete is sufficiently hardened, the Contractor will be required to have available at all times materials for the protection of the edges and surface of the unhardened concrete. Such protective materials shall consist of standard metal forms or wood plank having a nominal thickness of the pavement at its edge for the protection of the pavement edges and covering material such as curing paper or polyethylene sheeting material for the protection of the surface of the pavement. The metal forms, wood planks and curing paper shall be kept on trucks or towable vehicles, within reasonable hauling distance, at a site shown on the plans, or as designated by the Engineer. Or, as an alternate, rolled polyethylene sheeting of sufficient length and width may be used without the temporary side forms and if properly anchored, to cover the plastic concrete slab and exposed edge. The sheeting may be mounted on either the paver or a separate moveable bridge from which it can be unrolled without dragging over the plastic concrete surface. When rain appears imminent, all paving operations shall stop, and all available personnel shall begin covering the surface of the unhardened concrete with the protective covering. All pavement damaged shall be removed and replaced at no additional cost to the contract.

501-3.22 SURFACE TOLERANCES

DELETE: This Section.

501-3.23 QUALITY CONTROL PLAN

DELETE: This Section.

501-3.24 REMOVAL OF DEFECTIVE WORK

ADD:

At locations determined by the Engineer, the contractor shall be required to remove any pavement or sidewalk which is classified as defective. This includes any area where non-controlled (random) cracking occurs, unacceptable surface texturing or any other defect determined unacceptable by the Engineer. The pavement shall be removed to the nearest joint and replaced at the expense of the contractor. Prior to replacement, dowels and tie bars will be provided as directed by the Engineer.

501-3.25 SPALL REPAIR

ADD:

Where directed, spalls or scaled areas on existing concrete steps shall be repaired by first removing any loose aggregate. The repair area shall be chipped out to remove all unsound concrete. Following the chipping process, the area should be cleaned with a wire brush. The area should also be blown with compressed air as well as thoroughly cleaned with high pressure water jets to remove any dust or loose material. Immediately before filling the cavity, a primer shall be applied to the dry cleaned surface of all sides and bottom of the cavity. The epoxy material shall be placed in layers not greater than two inches thick. In cases of conflict, the Contractor shall follow the recommendations of the product manufacturer for the methods related to area preparation, material application and curing process. Any

repair material on the surrounding surfaces of the existing concrete steps shall be removed before it hardens.

METHOD OF MEASUREMENT

501-4.1

REVISE: This Section to read:

The quantity to be paid for shall be the number of square feet of sidewalk as specified, in place, completed and accepted. No separate measurement will be made for the required 4" granular bedding, excavation or other necessary incidentals required to complete this item.

The area of spall repair on the concrete steps shall be measured by the number of square feet of repaired area as directed by the Engineer.

BASIS OF PAYMENT

501-5.1 GENERAL

DELETE: This Section.

ADD:

Payment shall be made at the contract unit price per square foot for Portland Cement Concrete sidewalk measured as outlined in Section 501-4.1. This price shall be full compensation for furnishing and placing all materials, including any steel reinforcement, aggregate base, joint materials and texturing, labor, equipment, tools and incidentals necessary to complete this item.

Payment shall be made at the contract unit price per square foot for Spall Repair and shall be full compensation for furnishing and placing materials, labor, equipment, tools and incidentals necessary to complete the item.

Payment will be made under:

ITEM AR501605 5" PCC SIDEWALK - PER SQUARE FOOT.
ITEM AR800009 PCC SPALL REPAIR – PER SQUARE FOOT.

501-5.2

DELETE: This Section.

501-5.3 PRICE ADJUSTMENT

DELETE: This Section.

ITEM AR501900 – REMOVE PCC PAVEMENT

DESCRIPTION

501-1.1

ADD: To the second sentence.

The type of material to be removed consists of PCC sidewalk pavement (± 5 " average thickness). Pavement structure information was taken from airport records. The Contractor shall verify the type and thickness of materials to be removed. **No additional compensation will be allowed for any variations in the pavement sections actually encountered.**

ADD:

This work shall also include the repair of spalled and scaling surface and edges of the concrete steps in the areas identified in the plans or as directed by the Resident Engineer.

CONSTRUCTION METHODS

501-3.1

ADD:

The existing pavement areas to be removed shall be done in such a manner as to prevent damage to the adjacent structures and pavement. All pavement and base material removed shall be disposed of off airport property. All edges adjacent to existing pavements shall be saw cut full depth prior to removal as directed by the Engineer.

METHOD OF MEASUREMENT

501-4.1

ADD:

The area of pavement removal shall be measured by the number of square feet of sidewalk pavement removed, and properly disposed, as shown on the plans or as directed by the Resident Engineer.

If additional pavement or subgrade material is removed due to negligence of the Contractor, the additional quantity of pavement removal and replacement will not be measured for payment.

BASIS OF PAYMENT

501-5.1

ADD:

ITEM AR501690 PCC SIDEWALK REMOVAL – PER SQUARE FOOT.

ITEM 602 - BITUMINOUS PRIME COAT

MATERIALS

602-2.1 BITUMINOUS MATERIAL

ADD:

At the Contractor's option, Penetrating Emulsified Prime (PEP) may be used. The use of PEP shall be as outlined in the Standard Specifications for Road and Bridge Construction, Article 403.02.

CONSTRUCTION METHODS

602-3.3 APPLICATION OF BITUMINOUS MATERIAL

Add the following to the second paragraph:

Areas worn from hauling operations shall be re-primed at no additional cost to the Contract.

BASIS OF PAYMENT

602-5.1

ADD:

Payment will be made under:

ITEM AR602510 BITUMINOUS PRIME COAT - PER GALLON.

ITEM 603 – BITUMINOUS TACK COAT

MATERIALS

603-2.1 BITUMINOUS MATERIAL

ADD:

At the Contractor's option, SS-1vh may be used. The use of SS-1vh shall be as outlined in the Standard Specifications for Road and Bridge Construction, Article 406.02.

CONSTRUCTION METHODS

603-3.3 APPLICATION OF BITUMINOUS MATERIAL

ADD: The following to the second paragraph:

Areas worn from hauling operations shall be re-tacked at no additional cost to the Contract.

BASIS OF PAYMENT

603-5.1

ADD:

Payment will be made under:

ITEM AR603510 BITUMINOUS TACK COAT - PER GALLON.

ITEM 620 – PAVEMENT MARKING

MATERIALS

620-2.2 PAINT

ADD:

All paint shall be waterborne.

The paint shall contain no lead, chromium, cadmium or barium.

CONSTRUCTION METHODS

620-3.3 PREPARATION OF SURFACE

ADD:

Existing marking that is to be re-painted shall be cleaned using sand blasting or high-pressure water or other methods as approved by the Engineer to remove dirt, grease, laitance, loose or flaking paint and any paint that is not bonding, at no additional cost to the contract.

620-3.7 PAVEMENT MARKING REMOVAL

DELETE the words "shot blasting".

620-3.9 CLEAN UP

ADD:

The Contractor shall remove from the work area all debris, waste, loose or un-adhered reflective media, and by-products generated by the surface preparation and application operations to the satisfaction of the Resident Engineer. The Contractor shall dispose of these wastes in strict compliance with all applicable state, local and federal environmental statutes and regulations.

METHOD OF MEASUREMENT

620-4.1

ADD:

The quantity of permanent markings to be paid for shall be the number of square feet of painting with the specified material **measured only once to apply two coats** in conformance with the specifications and accepted by the Engineer.

BASIS OF PAYMENT

ADD:

Payment will be made under:

ITEM AR620520 PAVEMENT MARKING – WATERBORNE - PER SQUARE FOOT.
ITEM AR620900 PAVEMENT MARKING REMOVAL – PER SQUARE FOOT.

ITEM 754 – CONCRETE GUTTERS, DITCHES AND FLUMES

DESCRIPTION

754-1.1

ADD:

Specifically, this item consists of the removal and replacement of existing concrete combination curb and gutter (Type B-6.12) and/or concrete barrier curb (Type B) meeting IDOT Standard 606001-06 at the location(s) shown on the plans or as directed by the Engineer. All steel reinforcement and dowel bars shall be considered incidental to this pay item.

MATERIALS

754-2.2 JOINTS

DELETE: This section.

All joints shall be saw cut and filled with joint material conforming to Item 605.

METHOD OF MEASUREMENT

754-4.1

ADD:

No separate measurement will be made for the required 4" granular bedding, steel reinforcement, dowel bars, excavation, sawcutting for joints, joint material or other necessary incidentals required to complete this item.

BASIS OF PAYMENT

752-5.1

ADD:

Payment will be made at contract unit price per linear foot for the reconstruction of combination curb and gutter, completed and accepted in accordance with the plans and specifications. This price shall be full compensation for furnishing all materials, and for all preparation, excavation, removal of existing curb, granular bedding and compaction and installation of these materials, and for all labor, equipment, tools and incidentals necessary to complete the item. Granular bedding for all curb and gutters shall not be measured separately but shall be considered incidental to the proposed curb and gutter.

Payment will be made under:

ITEM AR754984 RECONSTRUCT COMB CURB & GUTTER - PER LINEAR FOOT.

DIVISION VIII – MISCELLANEOUS

ITEM 910 – ROADWAY SIGNAGE

DESCRIPTION

910-1.1

This work shall consist of furnishing Type 1, Type 2 or Type 3 Sign panels complete with reflectorized sign faces, legend and supplemental panels and installing them on newly erected sign supports as detailed in the plans at the locations shown or as directed by the Resident Engineer.

Work shall be in accordance with Section 720 and Section 729 of the Standard Specifications for Road and Bridge Construction and with IDOT Standards 720001-01, 720011-01 and 729001-01

MATERIALS

910-2.1

Materials shall meet the requirements of Sections 720 and 729 of the Standard Specifications for Road and Bridge Construction. Sign panels shall be as detailed in the plans.

CONSTRUCTION METHODS

910-3.1

This work shall also consist of furnishing and installing metal posts of the size and type specified, utilizing the direct burial methods as detailed in the plans.

910-3.2

Materials shall meet the requirements of Article 729 of the Standard Specifications for Road and Bridge Construction. Unless otherwise specified, only frangible galvanized posts shall be used. The post shall be Type B as designated on Illinois Department of Transportation Highway Standard 720011-01 and 729001-01.

910-3.3

The metal posts may be driven by hand or mechanical means to a minimum depth of 4 feet (Type B) measured from the ground line or as shown in the plans. The post shall be protected by suitable driving cap and if required by the Engineer, the material around the post will be compacted after driving.

Care shall be taken to avoid scratching, chipping or other damage to polyester or enamel-coated posts during handling and installation. Chips and scratches may be recoated in the field by a method meeting the coating manufacturer's recommendations except that chips and scratches totaling more than 5% of the surface area of any one post and/or more than 5% of the surface area in any one-foot segment of any one post shall be cause for rejection of the post.

If the post specified is too long, the Contractor may choose to cut the post to the required length. Any post so cut shall be installed with the cut end at the bottom.

METHOD OF MEASUREMENT

910-4.1

The quantity of roadway signs installed to be paid shall be the number of signs satisfactorily installed in accordance with applicable specifications and accepted by the Engineer. Sign panels, posts and supports shall be incidental to this item. No additional compensation shall be made for additional length of posts required.

Existing signs and sign posts shall be completely removed and disposed of by the Contractor off Airport property. The excavations shall be backfilled and compacted per the requirement of Section 152.

BASIS OF PAYMENT

910-5.1

Payment shall be made at the contract unit price for Roadway Sign per each and Remove Roadway Sign per each. This price shall be full compensation for all materials, including sign panels, posts and supports, erection of all signs at proposed locations, sign removals and for all materials, labor and equipment necessary to complete the work as described herein.

Payment will be made under:

ITEM AR910200 ROADWAY SIGN – PER EACH.
ITEM AR910915 REMOVE ROADWAY SIGN – PER EACH.

APPENDIX A - IDOT DIVISION OF AERONAUTICS POLICY MEMORANDA

State of Illinois
Department of Transportation
Division of Aeronautics

POLICY MEMORANDUM

February 20, 2014

Springfield

Number: 87-4

TO: CONSULTING ENGINEERS

SUBJECT: DETERMINATION OF BULK SPECIFIC GRAVITY (d) OF COMPACTED BITUMINOUS MIXES

A. SCOPE

This method of test covers the determination of the bulk specific gravity and the percent air, of core samples from compacted bituminous mixtures using a saturated surface-dry procedure.

B. DEFINITIONS

1. Bulk Specific Gravity (G_{mb}) ASTM 2726 or density is the weight per unit volume (gms/cc) of a mixture in its existing state of consolidation. The volume measurement for this specific gravity will include the volume of all the aggregate, asphalt, and air spaces (voids) in the aggregate particles and between the aggregate particles.
2. Theoretical Maximum Specific Gravity (G_{mm}) ASTM 2041 is the weight per unit volume (grams/cc) of a mixture assuming complete consolidation; i.e., all the air spaces (voids) between the aggregate particles are eliminated.
3. Percent Density is a measure of the degree of compaction in relation to the Theoretical Maximum Specific Gravity.
4. Percent Air is a measure of the air voids in the compacted pavement.

C. APPARATUS

1. Balance - The balance shall be accurate to 0.1 gm throughout the operating range. It may be mechanical or electrical and shall be equipped with a suitable suspension apparatus and holder to permit weighing of the core in water while suspended from the balance. If the balance is a beam type, it shall be set up so that the core is placed in the basket that is suspended from the zero (0) end of the balance arm.
2. Water bath - The container for immersing the core in water while suspended from the balance shall be equipped with an overflow outlet for maintaining a constant water level. This water bath should be large enough to handle full-depth cores. When testing several cores at the same time, a dish-pan, sink or suitable container may be used for soaking.

D. PROCEDURE

1. Prior to testing, cores shall be sorted on a flat surface in a cool place. The sample(s) shall be brushed with a wire brush and/or other suitable means, to remove all loose and/or foreign materials, such as seal coat, tack coat, foundation material, soil, paper and foil prior to testing.
2. If a core contains binder and surface or multiple lifts, the lifts shall be separated. This may be done in the following manner:
 - a. Mark the separation line between the two lifts.
 - b. Place the core in a freezer for 20-25 minutes.
 - c. Place a 2 or 3-inch wide chisel on the separation line and tap with a hammer. Rotate the core and continue this process until the core separates. Brush loose pieces with a wire brush if needed.
 - d. Allow 2-3 hours for the core to return to ambient temperature before proceeding.
3. Prepare the water baths for soaking and weighing with water at 77° F. Water baths should be maintained at this temperature throughout testing. Saturate the cores by submerging in the water for a minimum of 20 minutes.
4. With the balance and water bath properly assembled and zeroed, suspend the sample from the balance and submerge it in the water bath. The core must be placed with the original top and bottom in a vertical position. If necessary, add sufficient water to bring the water level up to the overflow outlet. Permit any excess to overflow. Read and record the Saturated Submerged Weight. Designate this weight as (C).
5. Remove the core from the water bath and blot the excess water from the surface of the core with an absorbent cloth or other suitable material. This must be done quickly to prevent the internal water from escaping.
6. Place the core on the balance and read and record the Saturated Surface-dry Weight in air. Designate this weight as (B).
7. Place the core in a tared pan and dry in an oven. When the core is dry (less than 0.5 gm loss in one hour), record the weight and subtract the pan weight. Designate this weight as (A).
8. The following calculation is used to determine the Bulk Specific Gravity of the core.

$$G_{mb} = \frac{A}{B - C}$$

G_{mb} = Bulk Specific Gravity

A = Oven dry weight

B = Saturated surface-dry weight

C = Saturated submerged weight

E. PERCENT DENSITY

The following calculation is used to determine the percent density of the core:

$$\% \text{ Density} = 100 \times \frac{G_{mb}}{G_m}$$

G_{mb} = Bulk Specific Gravity

G_{mm} = Theoretical Maximum Gravity*

Note: The Theoretical Maximum Gravity (G_{mm}) is determined from the mix design until current Vacuum Pycnometer test are available.

F. PERCENT AIR. To calculate the percent air, use the following formula:

$$\% \text{ Air} = 100 - \% \text{ Density}$$

G. WEIGHT PER SQUARE YARD OF COMPACTED MIXTURE. The actual weight per square yard of a compacted mixture can be calculated by using the Bulk Specific Gravity (G_{mb}). The volume of a square yard of pavement one (1) inch thick is 0.75 cubic foot. Taking the weight of a cubic foot of water as 62.37 pounds, one square yard of compacted material, one (1) inch thick weighs:

$$\text{Pounds / Sq. Yd. (1" thick)} = 0.75 \times 62.37 \times G_{mb}$$

Steven J. Long, P.E. Acting Chief Engineer

Supersedes Policy Memorandum 87-4, dated January 1, 2004

State of Illinois
Department of Transportation
Division of Aeronautics

POLICY MEMORANDUM

April 1, 2010

Springfield

Number 96-1

TO: CONSULTING ENGINEERS

SUBJECT: ITEM 610, STRUCTURAL PORTLAND CEMENT CONCRETE:
JOB MIX FORMULA APPROVAL & PRODUCTION TESTING.

- I. This policy memorandum addresses the Job Mix Formula (JMF) approval process and production testing requirements when Item 610 is specified for an airport construction contract.
- II. PROCESS
 - a. The contractor may submit a mix design with recent substantiating test data or he may submit a mix design generated by the Illinois Division of Highways with recent substantiating test data for approval consideration. The mix design should be submitted to the Resident Engineer.
 - b. The Resident Engineer should verify that each component of the proposed mix meets the requirements set forth under Item 610 of the *Standard Specifications for Construction of Airports* and/or the contract special provisions.
 - c. The mix design should also indicate the following information:
 1. The name, address, and producer/supplier number for the concrete.
 2. The source, producer/supplier number, gradation, quality, and SSD weight for the proposed coarse and fine aggregates.
 3. The source, producer/supplier number, type, and weight of the proposed flyash and/or cement.
 4. The source, producer/supplier number, dosage rate or dosage of all admixtures.
 - d. After completion of Items b and c above, the mix with substantiating test data shall be forwarded to the Division of Aeronautics for approval. Once the mix has been approved, the production testing shall be at the rate in Section III as specified herein.

III. PRODUCTION TESTING

- a. One set of cylinders or beams, depending on the strength specified, shall be cast for acceptance testing for each day the mix is used. In addition, at least one slump and one air test shall be conducted for each day the mix is used. If more than 100 c.y. of the mix is placed in a given day, additional tests at a frequency of 1 per 100 c.y. shall be taken for strength, slump, and air. The concrete shall have a maximum slump of three inches (3") and minimum slump of one inch (1") when tested in accordance with ASTM C-143. The air content of the concrete shall be between 5% and 8% by volume. At no time shall the temperature of the concrete exceed 90 degrees Fahrenheit.
- b. If the total proposed amount of Item 610 Structural Portland Cement Concrete as calculated by the Resident Engineer is less than 50 c.y. for the entire project, the following shall apply:
 - The Resident Engineer shall provide calculations of the quantity of Item 610 to the Division of Aeronautics.
 - One set of cylinders or beams, depending on the strength specified, shall be cast for acceptance testing.
 - One air content and one slump test shall be taken for acceptance testing.
 - The concrete shall have a maximum slump of three inches (3") and minimum of one inch (1") when tested in accordance with ASTM C-143. The air content of the concrete shall be between 5% and 8% by volume. At no time shall the temperature of the concrete exceed 90 degrees Fahrenheit.
- c. The Resident Engineer shall collect actual batch weight tickets for every batch of Item 610 concrete used for the project. The actual batch weight tickets shall be kept with the project records and shall be available upon request of the Department of Transportation.

Steven J. Long, P.E.
Acting Chief Engineer

Supersedes Policy Memorandum 96-1 dated January 1, 2004

State of Illinois
Department of Transportation
Division of Aeronautics

POLICY MEMORANDUM

February 20, 2014

Springfield, Illinois

Number 96-3

TO: CONSULTING ENGINEERS

SUBJECT: REQUIREMENTS FOR QUALITY ASSURANCE ON PROJECTS WITH
BITUMINOUS CONCRETE PAVING

I. SCOPE

The purpose of this policy memorandum is to define to the Consulting Engineer the requirements concerning Quality Assurance on bituminous concrete paving projects. Specifically, this memo applies whenever the Contractor is required to comply with the requirements set forth in Policy Memorandum 2003-1, "*Requirements for Laboratory, Testing, Quality Control, and Paving of Bituminous Concrete Mixtures*".

II. LABORATORY APPROVAL

The Resident Engineer shall review and approve the Contractor's plant laboratory to assure that it meets the requirements set forth in the contract specifications and Policy Memorandum 2003-1. This review and approval shall be completed prior to utilization of the plant for the production of any mix.

III. QUALITY ASSURANCE DURING PRODUCTION PAVING

- A. At the option of the Engineer, independent assurance tests may be performed on split samples taken by the Contractor for Quality Control testing. In addition, the Resident Engineer shall witness the sampling and splitting of these samples at the start of production and as needed throughout mix production. The Engineer may select any or all split samples for assurance testing. These tests may be performed at any time after sampling. The test results will be made available to the Contractor as soon as they become available.
- B. The Resident Engineer may witness the sampling and testing being performed by the Contractor. If the Resident Engineer determines that the sampling and Quality Control tests are not being performed according to the applicable test procedures, the Engineer may stop production until corrective action is taken. The Resident Engineer will promptly notify the Contractor, both verbally and in writing, of observed deficiencies. The Resident Engineer will document all witnessed samples and tests. The Resident Engineer may elect to obtain samples for testing, separate from the Contractor's Quality Control process, to verify specification compliance.

1. Differences between the Contractor's and the Engineer's split sample test results will be considered acceptable if within the following limits:

<u>Test Parameter</u>	<u>Acceptable Limits of Precision</u>
% Passing	
1/2 in.	5.0 %
No. 4	5.0 %
No. 8	3.0 %
No. 30	2.0 %
No. 200	2.2 %
Asphalt Content	0.3 %
Maximum Specific Gravity (G_{mm}) of Mixture	0.026
Bulk Specific Gravity (G_{mb}) of Gyratory Brix	0.045

2. In the event a comparison of the required plant test results is outside the above acceptable limits of precision, split or independent samples fail the control limits, an extraction indicates non-specification mix, or a continual trend of difference between Contractor and Engineer test results is identified, the Engineer will immediately investigate. The Engineer may suspend production while the investigation is in progress. The investigation may include testing by the Engineer of any remaining split samples or a comparison of split sample test results on the mix currently being produced. The investigation may also include review and observation of the Contractor's technician performance, testing procedure, and equipment. If a problem is identified with the mix, the Contractor shall take immediate corrective action. After corrective action, both the Contractor and the Engineer shall immediately resample and retest.

- C. The Contractor shall be responsible for documenting all observations, records of inspection, adjustments to the mixture, test results, retest results, and corrective actions in a bound hardback field book or bound diary which will become the property of IDA upon completion and acceptance of the project. The Contractor shall be responsible for the maintenance of all permanent records whether obtained by the Contractor, the Contractor's Consultants, or the producer of bituminous mix material. The Contractor shall provide the Engineer full access to all documentation throughout the progress of the work.

Results of adjustments to mixture production and tests shall be recorded in duplicate and sent to the Engineer.

IV. ACCEPTANCE BY ENGINEER

Density acceptance shall be performed according to Policy Memorandum 87-2, or according to the acceptance procedure outlined in the Special Provisions.

Steven J. Long, P.E. Acting Chief Engineer

Supersedes Policy Memorandum 96-3, dated January 1, 2004

State of Illinois Department of
Transportation Division of
Aeronautics

POLICY MEMORANDUM

June 22, 2018

Springfield, Illinois

Number 97-2

TO: CONSULTING ENGINEERS

SUBJECT: PAVEMENT MARKING PAINT ACCEPTANCE

I. SCOPE

The purpose of this policy memorandum is to define the procedure for acceptance of pavement marking paint.

II. RESIDENT ENGINEER'S DUTIES

The Resident Engineer shall follow the acceptance procedure outlined as follows:

- A. Require the contractor to furnish the name of the paint manufacturer, IDOT Test I.D. number and the Batch/Lot number proposed for use prior to beginning work. Notify the I.D.A. Materials Certification Engineer when this information is available.
- B. Require the manufacturer's certification before painting begins. Check the certification for compliance to the contract specifications.
 1. The certification shall be issued from the manufacturer and shall include the specification and the batch number.
 2. The paint containers shall have the manufacturer's name, the specification and the batch number matching the certification.
- C. If no batch number is indicated on the certification or containers, sample the paint according to the procedure for the corresponding paint type.
- D. If the I.D.A. Engineer of Materials indicates that batch number has not been previously sampled and tested, sample the paint according to the procedure for the corresponding paint type. The Division of Aeronautics will provide paint cans upon request by the Resident Engineer. Samples will only be taken in new epoxy lined cans and lids so that the paint will not be contaminated. It is important to seal the sample container immediately with the paint can lid to prevent the loss of volatile solvents.

Mark the sample cans with the paint color, manufacturer's name, and batch number. The paint samples and manufacturer's certification shall be placed in the mail or delivered within 24 hours after sampling. Address or deliver the samples to the Material's Certification Engineer at:

Illinois Department of Transportation
Division of Aeronautics
One Langhorne Bond Drive
Springfield, Illinois 62707

Sampling Procedures for Each Paint Type:

1. Waterborne or Solvent Base Paints
 - a. A sample consists of one one-pint cans taken per batch number. Before drawing samples, the contents of the component's container must be thoroughly mixed to make certain that any settled portion is fully dispersed.
 - b. Be sure to indicate to the contractor that acceptance of material is based upon a passing test of the paint material.

2. Epoxy Paint
 - a. Take separate one-pint samples of each paint component prior to marking. Before drawing samples, the contents of each component's container must be thoroughly mixed to make certain that any settled portion is fully dispersed. **Do not combine the two components or sample from the spray nozzle.**
 - b. Be sure to indicate to the contractor that acceptance of material is based upon a passing test of the paint material.

III. TESTING

The paint will be tested for acceptance by the IDOT Bureau of Materials and Physical Research for conformance to the contract specifications.



Alan D. Mlacnik, P.E.
Chief Engineer

Supersedes policy memorandum 97-2 dated January 1, 2004

State of Illinois
Department of Transportation
Division of Aeronautics

POLICY MEMORANDUM

June 12, 2014

Springfield, Illinois

Number 2003-1

TO: CONTRACTORS

SUBJECT: REQUIREMENTS FOR LABORATORY, TESTING, QUALITY CONTROL, AND PAVING OF SUPERPAVE HMA CONCRETE MIXTURES FOR AIRPORTS

I. SCOPE

The purpose of this policy memorandum is to define to the Contractor the requirements concerning the laboratory, testing, Quality Control, and paving of HMA mixtures utilizing Superpave technology. References are made to the most recent issue of the Standard Specifications for Construction of Airports (Standard Specifications) and to American Society for Testing and Materials (ASTM) testing methods. The Quality Assurance and acceptance responsibilities of the Resident Engineer are described in Policy Memorandum 96-3.

II. LABORATORY

The Contractor shall provide a laboratory located at the plant and approved by the Illinois Division of Aeronautics (IDA). The laboratory shall be of sufficient size and be furnished with the necessary equipment and supplies for adequately and safely performing the Contractor's Quality Control testing as well as the Resident Engineer's acceptance testing as described in Policy Memorandum 87-2.

The effective working area of the laboratory shall be a minimum of 600 square feet with a ceiling height of not less than 7.5 feet. Lighting shall be adequate to illuminate all working areas. It shall be equipped with heating and air conditioning units to maintain a temperature of 70° F ±5° F.

The laboratory shall have equipment that is in good working order and that meets the requirements set forth in the following ASTM test standards:

ASTM D 70	Test Method for Specific Gravity and Density of Semi-Solid Materials
ASTM C 117	Test Method for Materials Finer than 75 µm (No. 200) Sieve in Mineral Aggregates by Washing
ASTM C 136	Sieve or Screen Analysis of Fine and Coarse Aggregate
ASTM C 566	Total Moisture Content of Aggregate by Drying
ASTM D 75	Sampling Aggregates
ASTM D 2041	Theoretical Maximum Specific Gravity and Density of Bituminous Paving Mixtures

ASTM D 2172	Quantitative Extraction of Bitumen from Bituminous Paving Mixtures
AASHTO T 308-09	Ignition Method for Determining Asphalt Content (Illinois Modified)
ASTM D 2726	Bulk Specific Gravity of Compacted Bituminous Mixtures using Saturated Surface Dry Specimens
ASTM D 3203	Percent Air Voids in Compacted Dense and Open Bituminous Paving Mixtures
ASTM D 2950	Density of Bituminous Concrete in Place by Nuclear Method
ASTM D 4125	Asphalt Content of Bituminous Mixtures by Nuclear Method
ASTM C 127	Standard Test Method for Specific Gravity and Absorption of Coarse Aggregate
ASTM C 128	Standard Test Method for Specific Gravity and Absorption of Fine Aggregate

The laboratory and equipment furnished by the Contractor shall be properly calibrated and maintained. The Contractor shall maintain a record of calibration results at the laboratory. The Engineer may inspect measuring and testing devices at any time to confirm both calibration and condition. If the Engineer determines that the equipment is not within the limits of dimensions or calibration described in the appropriate test method, he may stop production until corrective action is taken. If laboratory equipment becomes inoperable or insufficient to keep up with mix production testing, the Contractor shall cease mix production until adequate and/or sufficient equipment is provided.

III. MIX DESIGN SUBMITTAL

Based upon data and test results submitted by the Contractor, the Illinois Division of Aeronautics Engineer of Construction & Materials shall issue the final Job Mix Formula (JMF) approval letter that concurs or rejects the Contractor's proposed JMF. The Contractor will be required to perform the sampling and laboratory testing and develop a complete mix design, according to the following guidelines: Mix design submittals should be sent to IDA, Construction/Material Section, Attn: Certification and Mixtures Engineer. Note: Quality Control (QC) Managers shall be Level III QC/QA qualified and will be responsible for all mix designs. All Technicians obtaining samples and performing gradations shall have successfully completed the IDOT Mixture Aggregate Technician Course and Technicians performing mix design testing and plant sampling/testing shall have successfully completed the IDOT Bituminous Concrete Level 1 Technician Course under the Illinois Department of Transportation, Bureau of Materials & Physical Research QC/QA Training Program.

A. Preliminary Mix Design Submittal

Top half of the IDOT Mix Design Software Cover Sheet (QC/QA Package) should be completed for the aggregate mix design parameters and should include the following:

1. Producer name, Producer # and Producer location of each aggregate (Producers are assigned Producer numbers by IDOT Central Bureau of Materials)
2. Material code for each aggregate

3. Aggregate Gradations per ASTM C-136 (The Contractor shall obtain representative samples of each aggregate)
4. Material code for each aggregate (i.e. 022CM11, etc.)
5. Proposed Aggregate Blend (% for each aggregate) Note: Based on the gradation results, the Contractor shall select the blend percentages that comply with the Standard Specifications, Section 401/403 – 3.2 JOB MIX FORMULA, Table 2. (Appendix A)
6. Producer name, Producer #, and specific gravity of the proposed asphalt cement
7. IDOT approved PG Binder 64-22 shall be used unless otherwise specified by the IDA Engineer of Construction & Materials.

B. Mixture Design & Testing

Design Parameters

Gyrations (N_{des}) – per Standard Specifications, Section 401/403 – 3.2 (JMF), Table 1

Asphalt Content – AC% per Standard Specifications, Section 401/403 – 3.2 (JMF), Table 2

Maximum Specific Gravity – G_{mm} (ASTM D 2041)

Bulk Specific Gravity – G_{mb} (ASTM D 2726)

% air voids – V_a (ASTM D3203) per Standard Specifications, Section 401/403 – 3.2 (JMF), Table 2

VFA % – per Standard Specifications, Section 401/403 – 3.2 (JMF), Table 1

Mixture Tests

After verification and approval by IDA of the proposed design information from step A., the Contractor shall perform mixture tests on 4 gyratory brix (4 point mix design) to determine the optimum AC content for the target Air Voids.

C. Mix Design Submittal

The Preliminary JMF including all test results shall be reported to IDA, Construction/Material Section, Attn: Certification and Mixtures with the following data:

- a) Aggregate & asphalt cement material codes
- b) Aggregate & asphalt cement producer numbers, names, and locations
- c) Percentage of each individual aggregate
- d) Aggregate blend % for each sieve
- e) AC Specific Gravity
- f) Bulk Specific Gravity and Absorption for each aggregate
- g) Summary of Superpave Design Data: AC % Mix, G_{mb} , G_{mm} , VMA, Voids (Total Mix), Voids Filled, V_{be} , P_{be} , P_{ba} , G_{se}
- h) Optimum design data listing: AC % Mix, G_{mb} , G_{mm} , VMA, Voids (Total Mix), Voids Filled, G_{se} , G_{sb}

- i) Percent of asphalt that any RAP will add to the mix
- j) Graphs for the following: gradation on 0.45 Power Curve, AC vs. Voids (Total Mix), AC vs. Specific Gravities, AC vs. Voids Filled, AC vs. VMA

D. Mix Approval

Once the proposed JMF is reviewed and approved by IDA, a JMF approval letter will be issued to the contractor. Production of HMA is not authorized until a JMF letter has been issued. When a Test Section is specified as part of the contract, the proposed JMF shall be considered preliminary until it passes all Test Section requirements.

E. Change in Material Sources

The above procedure, III. MIX DESIGN SUBMITTAL shall be repeated for each change in source or gradation of materials.

IV. MIX PRODUCTION TESTING

The Quality Control of the manufacture and placement of HMA mixtures is the responsibility of the Contractor. The Contractor shall perform or have performed the inspection and tests required to assure conformance to contract requirements. Quality Control includes the recognition of defects and their immediate correction. This may require increased testing, communication of test results to the plant or the job site, modification of operations, suspension of HMA production, rejection of material, or other actions as appropriate. The Resident Engineer shall be immediately notified of any failing tests and subsequent remedial action. Form AER M-14 shall be reported to IDA, Construction/Material Section, Attn: Certification and Mixtures Engineer and the Resident Engineer no later than the start of the next work day. The Contractor shall provide a Quality Control (QC) Manager who will have overall responsibility and authority for Quality Control. This individual shall have successfully completed the IDOT Division of Highways HMA Concrete Level II Technician Course "HMA Proportioning and Mixture Evaluation." In addition to the QC Manager, the Contractor shall provide sufficient and qualified personnel to perform the required visual inspections, sampling, testing, and documentation in a timely manner.

- A. Gradations for Mixture Proportioning: Aggregate gradations for proportioning (ASTM C-136) are required at a minimum of one per week when mix is produced. Aggregate gradations can be either hot bin gradations for batch plants or stockpile gradations for drier drum plants. Hot bin gradations may be reported on either form AER 9 or on the Division of Highways QC/QA package "Grad 1" Tab in the Daily HMA Plant Reporting Module. Stockpile gradations shall be shown on form MI504QC from the "Print Out" Tab in the Aggregate Stockpile Module of The Division of Highways QC/QA Package.
- B. Production Mixture Testing: 1 per 1000 tons of the following (if total daily quantity is \leq 200 tons (small quantity) then a mix sample is not required and this quantity may be added on to next day's total for testing. Two consecutive days without testing is not allowed.): Reflux extraction (ASTM D2172) or Ignition oven test showing gradation and AC Content, Maximum Specific Gravity (ASTM D 2041), Bulk Specific Gravity (ASTM D 2726) and % Air Voids (ASTM D 3203). Calculations of the results (including weight data) shall be shown on the "Voids 1" and "IGN & NUC AC 1" tab printouts from the Division of Highways QC/QA Package Daily HMA Plant Reporting module.

- C. A certification from the quarry for the total quantity of aggregate listing the source, gradation type, and quality designation of aggregate shipped. The Aggregate Certification of Compliance (AER18) may be used by the contractor for this purpose.
- D. Original asphalt shipping tickets listing the source and type of asphalt shipped.
- E. Check sample tests at a rate of 1/5000 tons randomly selected by the R.E. shall be sent with an identification sheet to an independent laboratory designated by the Division of Aeronautics. If the project is < 5000 tons, 1 sample selected randomly shall be sent.
- F. Bituminous Test Summary (AER 14) Note: The R.E. should make certain that the Contractor fills this form out daily (for mix production days) and distributes it daily to the Division of Aeronautics and R.E. The Contractor (QC Manager) is required to note any adjustments to the mix or to the plant (proportioning) in the "Remarks/Corrective Measures" section of the AER 14.

V. QUALITY CONTROL

- A. Control Limits (Control Charts used for projects > 4000 tons per bituminous concrete pay item)

Target values shall be determined from the approved JMF. The target values shall be plotted on the control charts within the following control limits:

Control Limits

<u>Parameter</u>	<u>Individual Test</u>	<u>Moving Avg. of 4</u>
% Passing		
1/2 in.	± 7 %	±4 %
No. 4	±7 %	±4 %
No. 8	±5 %	±3 %
No. 30	±4 %	±2.5 %
No. 200 *	±2.0 % *	±1.0 % *
Asphalt Content	±0.45 %	±0.2 %

* No. 200 material percent's shall be based on washed samples. Dry sieve gradations (-200) shall be adjusted based on anticipated degradation in the mixing process.

- B. Control Charts (Control Charts used for projects > 4000 tons per bituminous concrete pay item)

Standardized control charts shall be maintained by the Contractor at the field laboratory. The control charts shall be displayed and be accessible at the field laboratory at all times for review by the Engineer. The individual required test results obtained by the Contractor shall be recorded on the control chart immediately upon completion of a test, but no later than 24 hours after sampling. Only the required plant tests and resamples shall be recorded on the control chart. Any additional testing of check samples may be used for controlling the Contractor's processes, but shall be documented in the plant diary.

The results of assurance tests performed by the Resident Engineer will be posted as soon as available.

The following parameters shall be recorded on control charts:

1. Combined Gradation of Hot-Bin (Batch Plant) or Combined Belt Aggregate Samples (Drier Drum Plant) (% Passing 1/2 in., No. 4., No. 8, No. 30, and No. 200 Sieves)
2. Asphalt Content
3. Bulk Specific Gravity (G_{mb})
4. Maximum Specific Gravity of Mixture (G_{mm}) C.

Corrective Action for Required Plant Tests

Control Limits for each required parameter, both individual tests and the average of four tests, shall be exhibited on control charts. Test results shall be posted within the time limits previously outlined.

1. Individual Test Result. When an individual test result exceeds its control limit, the Contractor shall immediately resample and retest. If at the end of the day no material remains from which to resample, the first sample taken the following day shall serve as the resample as well as the first sample of the day. This result shall be recorded as a retest. If the retest passes, the Contractor may continue the required plant test frequency. Additional check samples should be taken to verify mix compliance.
2. Asphalt Content. If the retest for asphalt content exceeds control limits, mix production shall cease and immediate corrective action shall be instituted by the Contractor. After corrective action, mix production shall be restarted, the mix production shall be stabilized, and the Contractor shall immediately resample and retest. Mix production may continue when approved by the Engineer. The corrective action shall be documented.

Inability to control mix production is cause for the Engineer to stop the operation until the Contractor completes the investigation identifying the problems causing failing test results.

3. Combined Aggregate/Hot-Bin. For combined aggregate/hot-bin retest failures, immediate corrective action shall be instituted by the Contractor. After corrective action, the Contractor shall immediately resample and retest. The corrective action shall be documented.
 - a. Moving Average. When the moving average values trend toward the moving average control limits, the Contractor shall take corrective action and increase the sampling and testing frequency. The corrective action shall be documented.

The Contractor shall notify the Engineer whenever the moving average values exceed the moving average control limits. If two consecutive moving average values fall outside the moving average control limits, the

Contractor shall cease operations. Corrective action shall be immediately instituted by the Contractor. Operations shall not be reinstated without the approval of the Engineer. Failure to cease operations shall subject all subsequently produced material to be considered unacceptable.

- b. Mix Production Control. If the Contractor is not controlling the production process and is making no effort to take corrective action, the operation shall stop.

VI. TEST SECTION AND DENSITY ACCEPTANCE (**Note: Applies only when specified.**)

- A. The purpose of the test section is to determine if the mix is acceptable and can be compacted to a consistent passing density.

A quick way to determine the compaction of the mix is by the use of a nuclear density gauge in the construction of a growth curve. An easy way to construct a growth curve is to use a good vibratory roller. To construct the curve, an area the width of the roller in the middle of the mat is chosen and the roller is allowed to make one compaction pass. With the roller stopped some 30 feet away, a nuclear reading is taken and the outline of the gauge is marked on the pavement. The roller then makes a compaction pass in the opposite direction and another reading is taken. This scenario is continued until at least two (2) passes are made past the maximum peak density obtained.

The maximum laboratory density potential of a given mix is a direct function of the mix design air voids. Whereas, the actual maximum field density is a function of the type of coarse aggregates, natural or manufactured sands, lift thickness, roller type (static or vibratory), roller and paver speed, base condition, mix variation, etc. All of these items are taken into consideration with the growth curve.

1. High Density in the Growth Curve. If the growth curve indicates a maximum achievable field density of between 95 to 98 percent of the Theoretical Maximum Density (D), you can proceed with the Rolling Pattern. On the other hand, if the maximum achievable density is greater than 98 percent, a quick evaluation (by use of an extractor, hot bin gradations, nuclear asphalt determination, etc.) must be made of the mix. When adjustments are made in the mix, a new growth curve shall be constructed.
2. Low Density in the Growth Curve. If the growth curve indicates the maximum achievable density is below 94 percent, a thorough evaluation of the mix, rollers, and laydown operations should be made. After a thorough evaluation of all factors (mix, rollers, etc.), asphalt or gradation changes may be in order as directed by the Engineer. Again, any changes in the mix will require a new growth curve. Note that the nuclear density test is a quality control tool and not an acceptance test. All acceptance testing is to be conducted by the use of cores, unless otherwise specified.

3. Acceptance of Test Section. The Contractor may proceed with paving the day after the test section provided the following criteria have been met:
 - a. Four random locations (2 cores per location cut longitudinally and cored by the Contractor) will be selected by the Engineer within the test strip. All the cores must show a minimum of 94% density.
 - b. All Superpave and extraction test results from mix produced for the test section must be within the tolerances required by specification.
 - c. The Contractor shall correlate his nuclear gauge to the cores taken in the test section. Additional cores may be taken at the Contractor's expense for this purpose within the test section area, when approved by the Engineer.

4. Density Acceptance under Production Paving. The responsibility for obtaining the specified density lies with the Contractor. Therefore, it is important that the nuclear density gauge operator communicate with the roller operators to maintain the specified density requirements. The Contractor shall provide a qualified HMA Density Tester who has successfully completed the Department's "HMA Nuclear Density Testing Course" to run all required density tests on the job site. Density acceptance testing, unless otherwise specified, is described as follows:
 - a. The Contractor shall cut cores at random locations within 500 ton sublots as directed by the Resident Engineer.
 - b. The cores should be extracted so as not to damage them, since they are used to calculate the Contractor's pay.
 - c. The Engineer will run preliminary G_{mb} tests on the cores to give the Contractor an indication of how compaction is running for the next day's paving.
 - d. A running average of four (4) Maximum Theoretical Gravities (G_{mm}) will be used for calculating percent compaction.
 - e. Final core density tests and pay calculations will be performed by the Resident Engineer and delivered to the Contractor.
 - f. Should the contractor wish to resample the pavement as a result of pay calculations resulting in less than 100% payment the request must be made within 48 hours of receipt of the original payment calculation.

Steven J. Long, P.E. Acting Chief Engineer

Supersedes Policy Memorandum 2003-1 dated May 1, 2014

APPENDIX A

AGGREGATE BITUMINOUS BASE COURSE

Percentage by Weight Passing Sieves
Job Mix Formula (JMF)

Sieve Size	Gradation B Range 1" Maximum	Ideal Target
1-1/4 in.	---	---
1 in.	100	100
3/4 in.	93 – 97	95
1/2 in.	75 – 79	77
3/8 in.	64 – 68	66
No. 4	45 – 51	48
No. 8	34 – 40	37
No. 16	27 – 33	30
No. 30	19 – 23	21
No. 100	6 – 10	8
No. 200	4 – 6	5
Bitumen %:		
Stone	4.5 – 7.0	5.5

AGGREGATE BITUMINOUS SURFACE COURSE

Percentage by Weight Passing Sieves
Job Mix Formula (JMF)

Sieve Size	Gradation B Range ¾" Maximum	Ideal Target
1 in.	100	---
¾ in.	100	100
½ in.	99 - 100	100
⅜ in.	91 - 97	94
No. 4	56 – 62	59
No. 8	36 - 42	39
No. 16	27 - 32	30
No. 30	19 - 25	22
No. 100	7 – 9	8
No. 200	5 – 7	6

Bitumen %:		
Stone	5.0 – 7.0	6.0

APPENDIX B – IDOT HIGHWAY STANDARDS

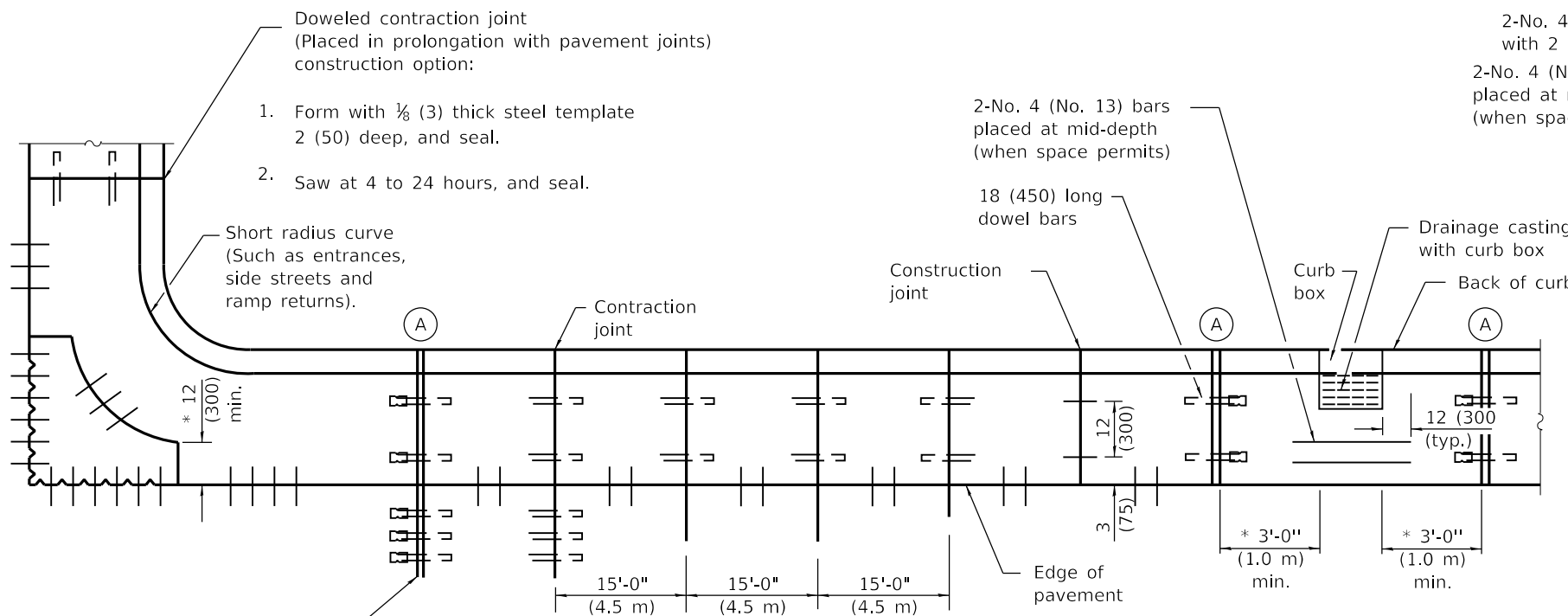

PLAN
ADJACENT TO PCC PAVEMENT OR PCC BASE COURSE

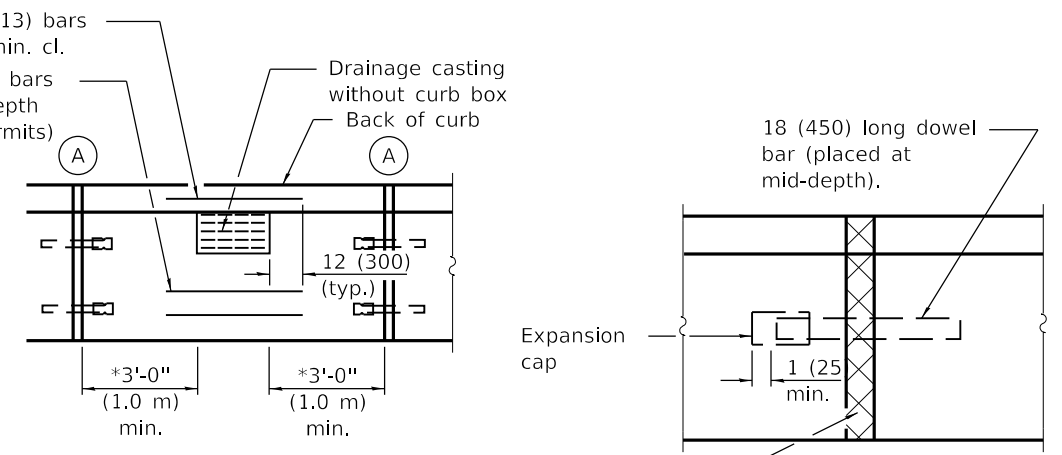

DETAIL A
EXPANSION JOINT

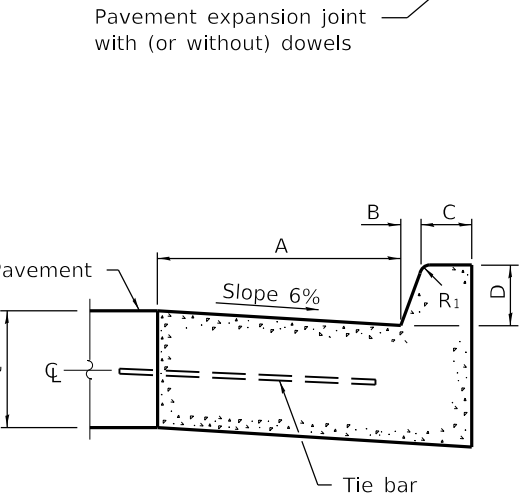

BARRIER CURB

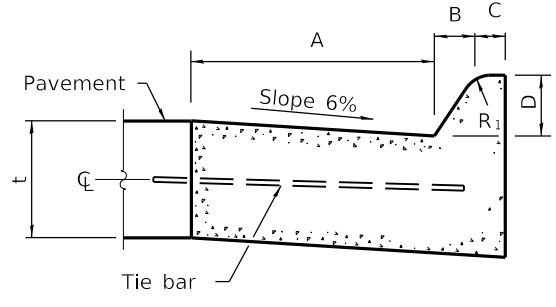

MOUNTABLE CURB

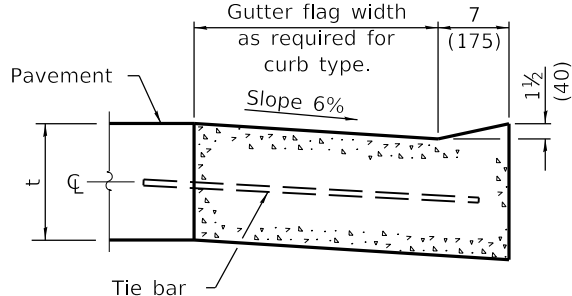

DEPRESSED CURB (TYPICAL)

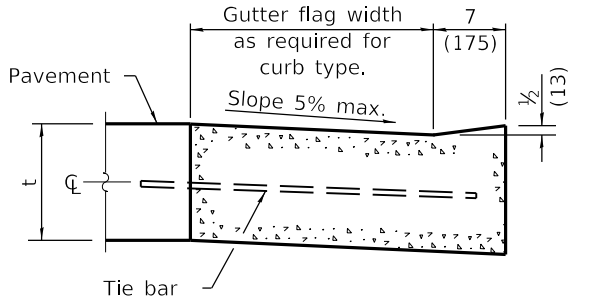

DEPRESSED CURB ADJACENT TO CURB RAMP ACCESSIBLE TO THE DISABLED

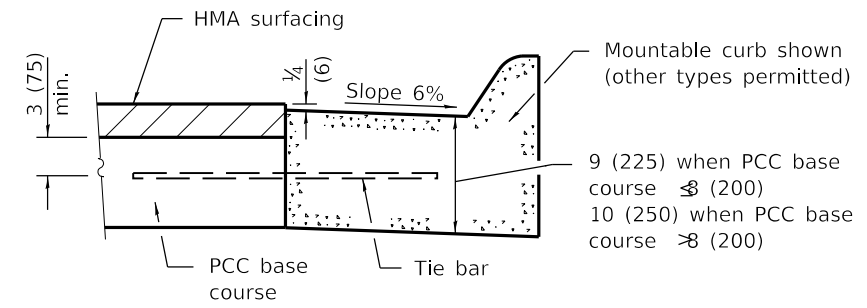

ADJACENT TO PCC BASE COURSE WITH HMA SURFACING

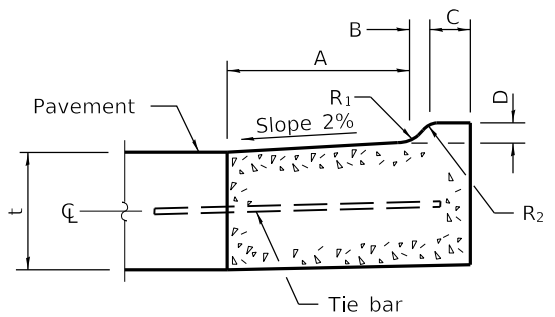

M-2.06 (M-5.15) and M-2.12 (M-5.30)

TYPE	A	B	C	D	R ₁
B-6.06 *	6	1	6	6	1
(B-15.15)	(150)	(25)	(150)	(150)	(25)
B-6.12	12	1	6	6	1
(B-15.3)	(300)	(25)	(150)	(150)	(25)
B-6.18	18	1	6	6	1
(B-15.45)	(450)	(25)	(150)	(150)	(25)
B-6.24	24	1	6	6	1
(B-15.60)	(600)	(25)	(150)	(150)	(25)
B-9.12	12	2	5	9	1
(B-22.30)	(300)	(50)	(125)	(225)	(25)
B-9.18	18	2	5	9	1
(B-22.45)	(450)	(50)	(125)	(225)	(25)
B-9.24	24	2	5	9	1
(B-22.60)	(600)	(50)	(125)	(225)	(25)

* For corner islands only.

TYPE	A	B	C	D	R ₁	R ₂
M-2.06	6	2	4	2	3	2
(M-5.15)	(150)	(50)	(100)	(50)	(75)	(50)
M-2.12	12	2	4	2	3	2
(M-5.30)	(300)	(50)	(100)	(50)	(75)	(50)
M-4.06	6	4	3	4	3	NA
(M-10.15)	(150)	(100)	(75)	(100)	(75)	NA
M-4.12	12	4	3	4	3	NA
(M-10.30)	(300)	(100)	(75)	(100)	(75)	NA
M-4.18	18	4	3	4	3	NA
(M-10.45)	(450)	(100)	(75)	(100)	(75)	NA
M-4.24	24	4	3	4	3	NA
(M-10.60)	(600)	(100)	(75)	(100)	(75)	NA
M-6.06	6	6	2	6	2	NA
(M-15.15)	(150)	(150)	(50)	(150)	(50)	NA
M-6.12	12	6	2	6	2	NA
(M-15.30)	(300)	(150)	(50)	(150)	(50)	NA
M-6.18	18	6	2	6	2	NA
(M-15.45)	(450)	(150)	(50)	(150)	(50)	NA
M-6.24	24	6	2	6	2	NA
(M-15.60)	(600)	(150)	(50)	(150)	(50)	NA

GENERAL NOTES

The bottom slope of combination curb and gutter constructed adjacent to pcc pavement shall be the same slope as the subbase or 6% when subbase is omitted.

t = Thickness of pavement.

Longitudinal joint tie bars shall be No. 6 (No. 19) at 36 (900) centers in accordance with details for longitudinal construction joint shown on Standard 420001.

A minimum clearance of 2 (50) between the end of the tie bar and the back of the curb shall be maintained.

The dowel bars shown in contraction joints will only be required for monolithic construction.

See Standard 606301 for details of corner islands.

All dimensions are in inches (millimeters) unless otherwise shown.

DATE	REVISIONS
1-1-18	Revised General Note for tie bar spacing to 36 (900) cts.
1-1-15	Added B-6.06 (B-15.15) barrier curb and gutter to table (corner islands only).

CONCRETE CURB TYPE B AND COMBINATION CONCRETE CURB AND GUTTER
(Sheet 1 of 2)

STANDARD 606001-07

Illinois Department of Transportation

PASSED January 1, 2018
Michael Brand
ENGINEER OF POLICY AND PROCEDURES

APPROVED January 1, 2018
Maureen M. Beck
ENGINEER OF DESIGN AND ENVIRONMENT

ISSUED 1-1-97

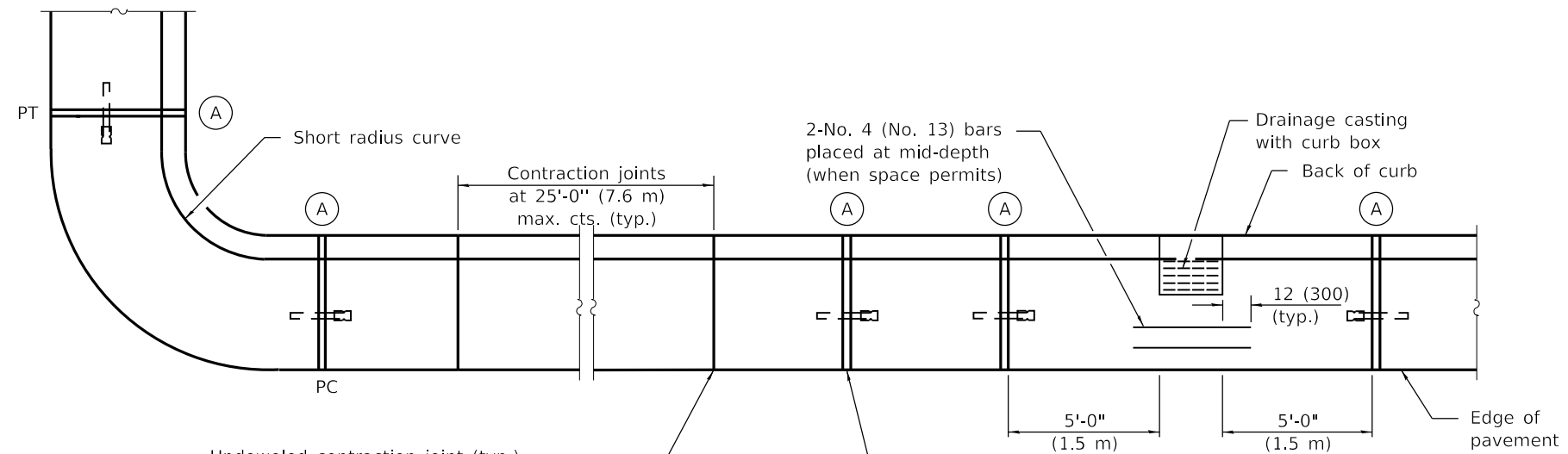

Undoweled contraction joint (typ.) construction options:

1. Form with 1/8 (3) thick steel template 2 (50) deep, and seal.
2. Saw 2 (50) deep at 4 to 24 hours, and seal.
3. Insert 3/4 (20) thick preformed joint filler full depth and width.

Construction joint
2-No. 4 (No. 13) bars with 2 (50) min. cl.

2-No. 4 (No. 13) bars placed at mid-depth (when space permits)

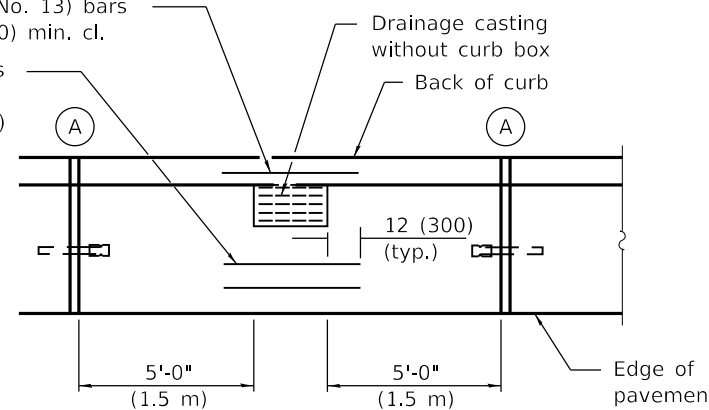

PLAN

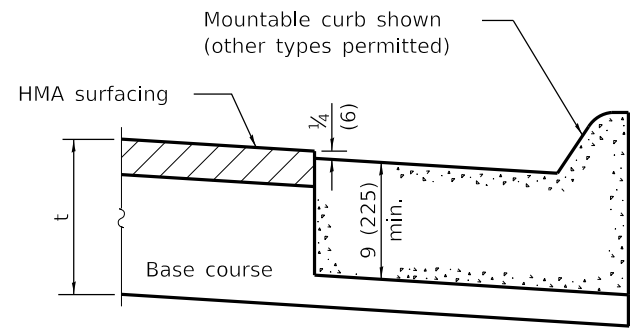

ON DISTURBED SUBGRADE

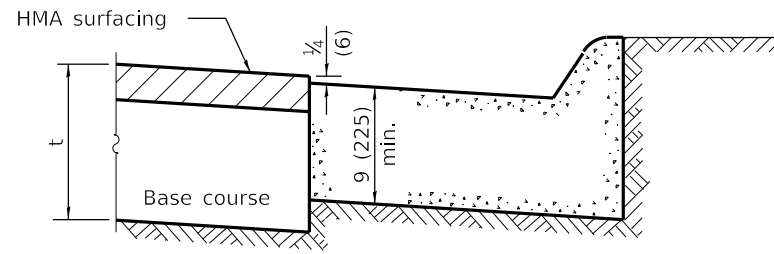

ON UNDISTURBED SUBGRADE

ADJACENT TO FLEXIBLE PAVEMENT

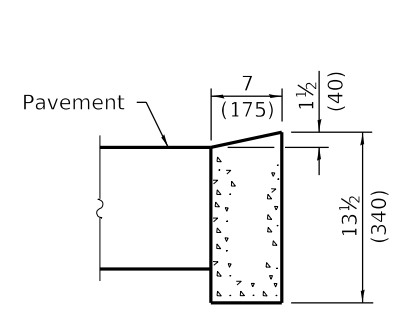

DEPRESSED CURB

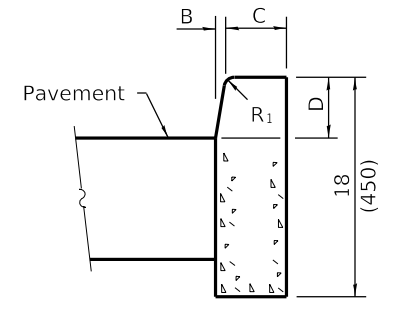

BARRIER CURB

ADJACENT TO FLEXIBLE PAVEMENT

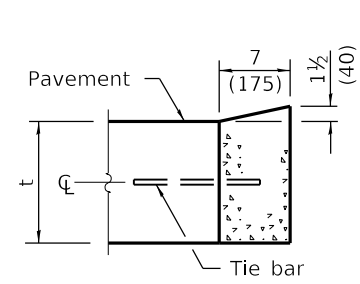

DEPRESSED CURB

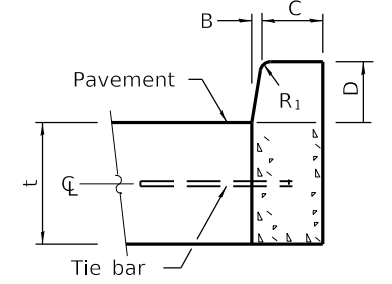

BARRIER CURB

ADJACENT TO PCC PAVEMENT OR PCC BASE COURSE

CONCRETE CURB TYPE B

CONCRETE CURB TYPE B AND COMBINATION CONCRETE CURB AND GUTTER

(Sheet 2 of 2)

STANDARD 606001-07

Illinois Department of Transportation

PASSED January 1, 2018
Michael Beard
ENGINEER OF POLICY AND PROCEDURES

APPROVED January 1, 2018
Maurice M. Beck
ENGINEER OF DESIGN AND ENVIRONMENT

ISSUED 1-1-97

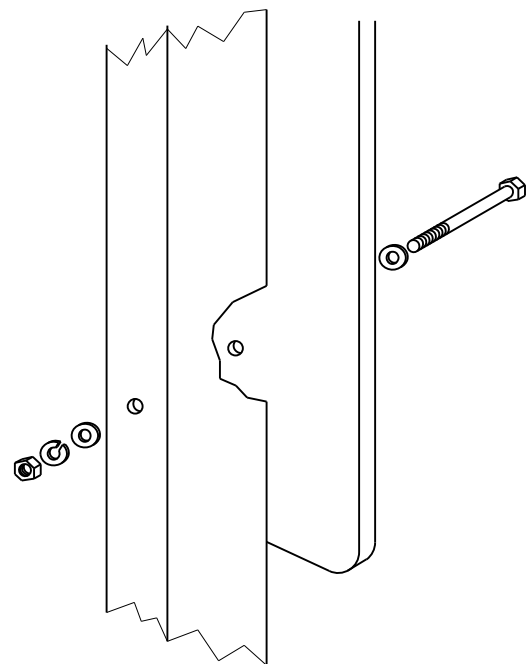

Sign panel 36 (900) wide or less

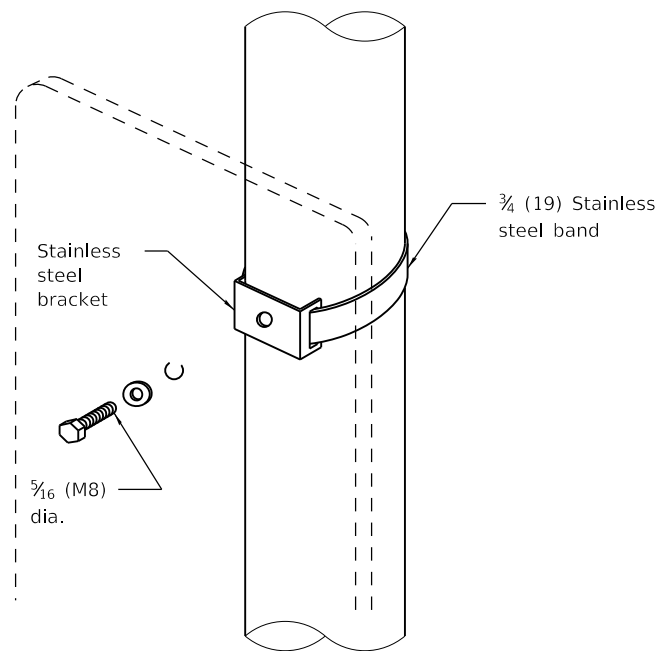

Sign panel 36 (900) wide or less

Section modulus (minimum)	Axis A	Axis B
Steel	0.050 in. ³ (819 mm ³)	0.105 in. ³ (1720 mm ³)
Aluminum	0.150 in. ³ (2458 mm ³)	0.315 in. ³ (5162 mm ³)

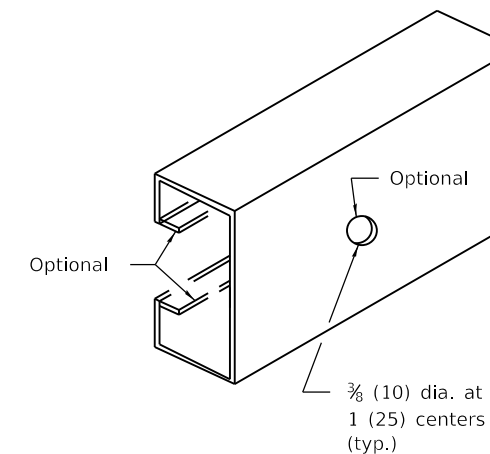
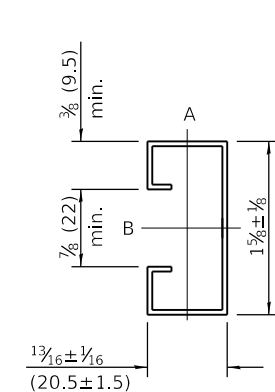

SUPPORTING CHANNEL DETAILS

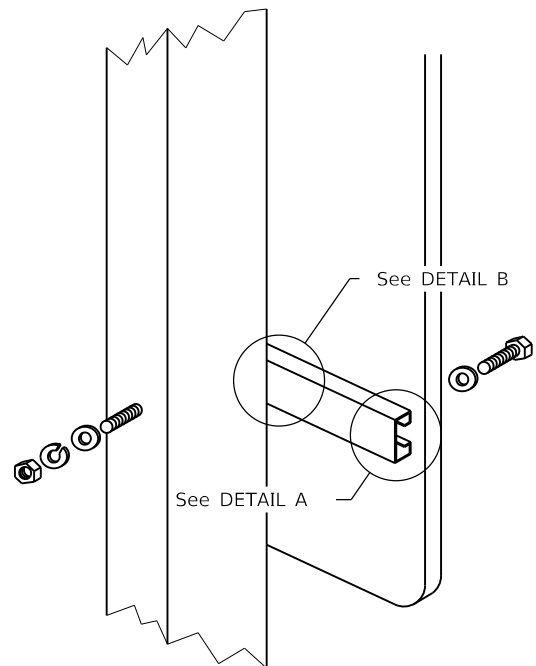

Sign panel over 36 (900) wide

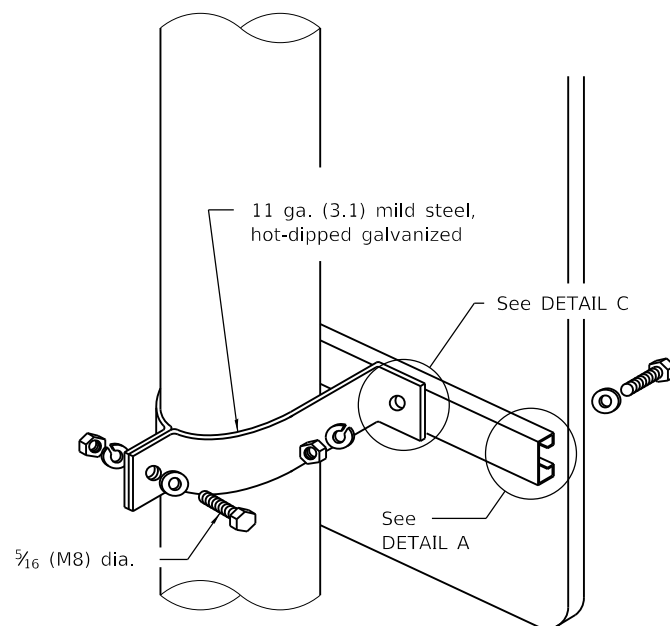

Sign panel over 36 (900) wide

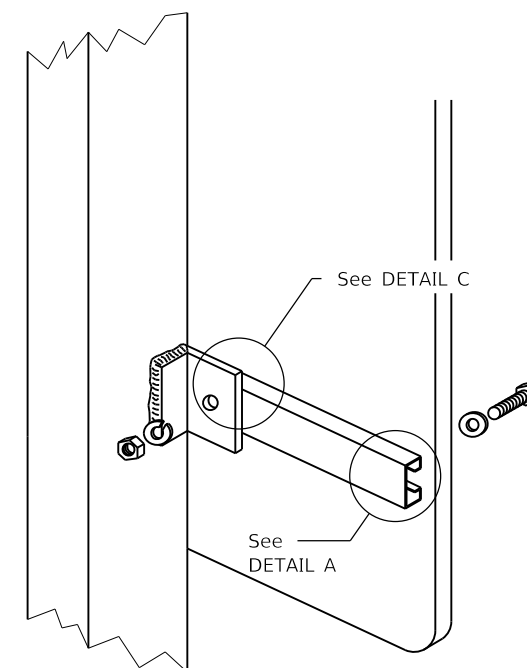

ROUTE MARKER ASSEMBLY

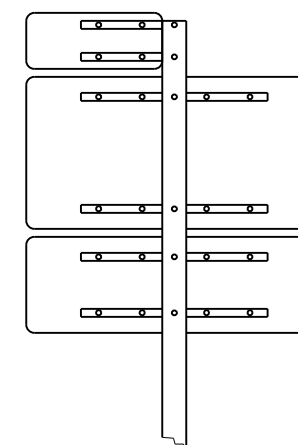

WOOD OR TELESCOPING STEEL POSTS

LIGHT OR SIGNAL STANDARDS

BREAKAWAY STEEL TUBING POSTS
(All sign panel sizes)

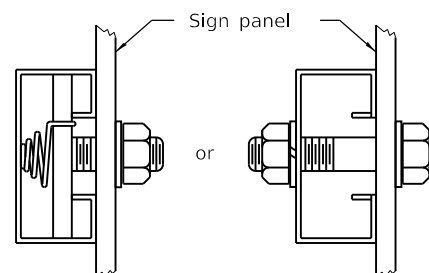

DETAIL A

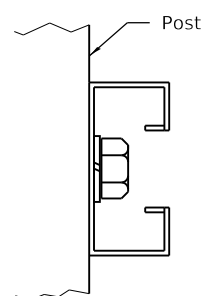

DETAIL B

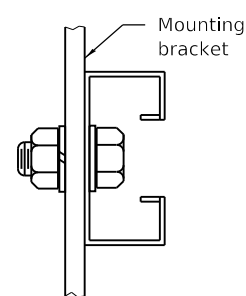

DETAIL C

All dimensions are in inches (millimeters) unless otherwise shown.

DATE	REVISIONS
1-1-09	Switched units to English (metric).
1-1-97	Renum. Standard 2319-6.

SIGN PANEL MOUNTING DETAILS

STANDARD 720001-01

Illinois Department of Transportation

PASSED January 1, 2009

ENGINEER OF OPERATIONS

APPROVED January 1, 2009

ENGINEER OF DESIGN AND ENVIRONMENT

ISSUED 1-1-97

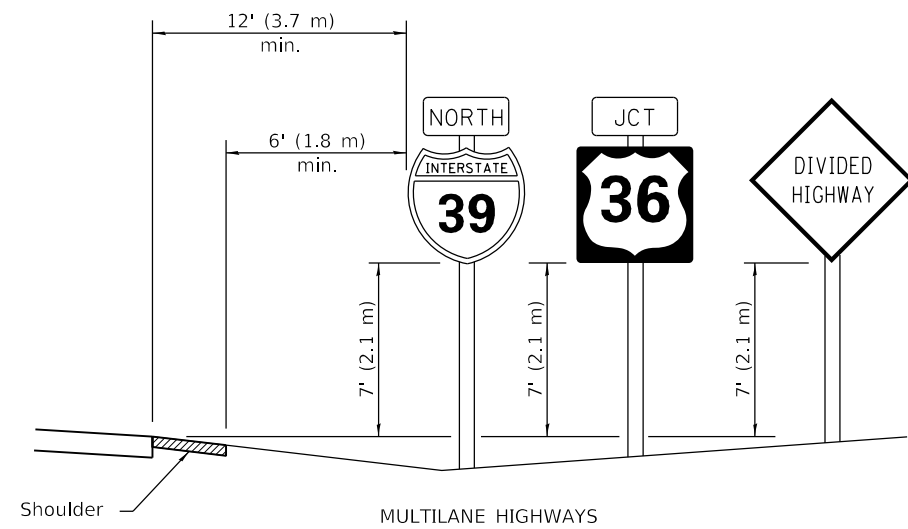

MULTILANE HIGHWAYS

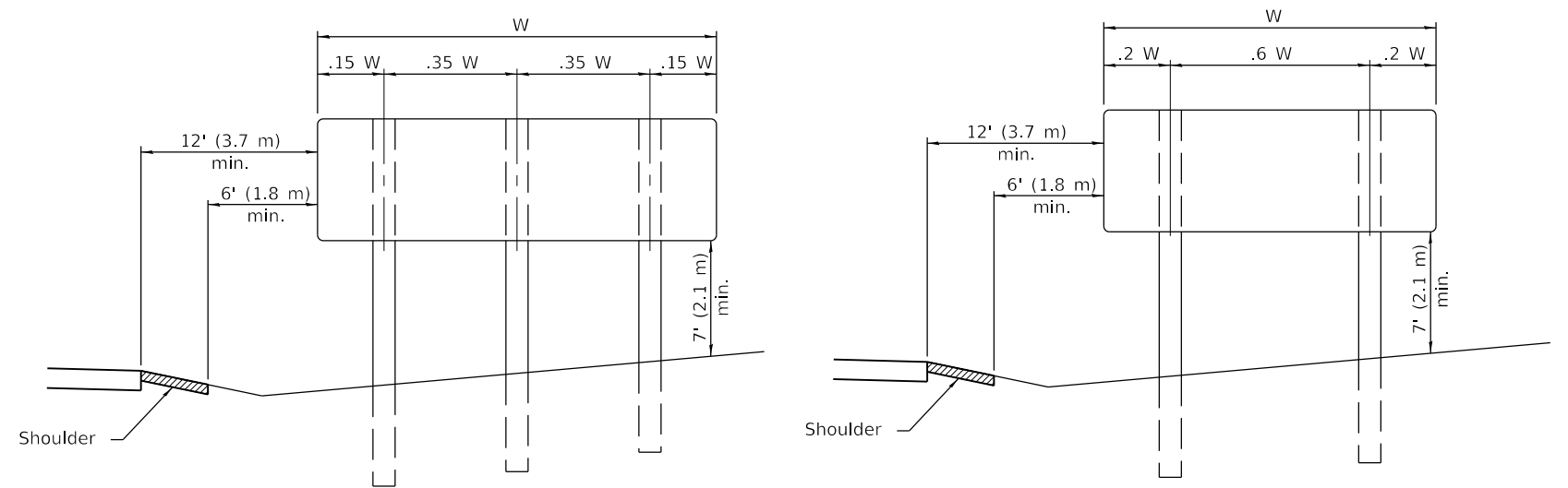

POST SPACING FOR NON-FREEWAY SIGN PANELS

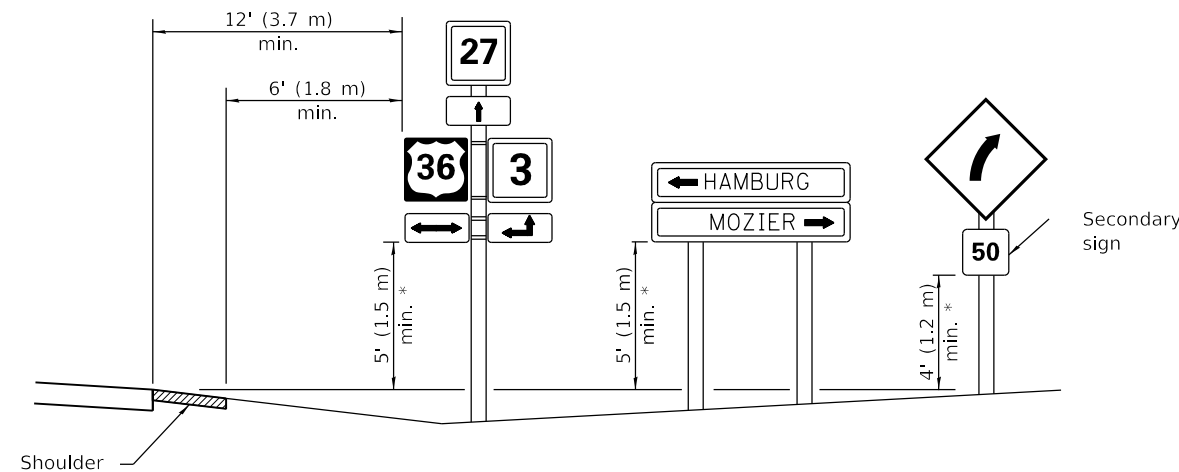

* In any area where parking is likely to occur or where there are obstructions to view or where signs are located over sidewalks, the height shall be at least 7' (2.1 m).

TWO LANE RURAL HIGHWAYS

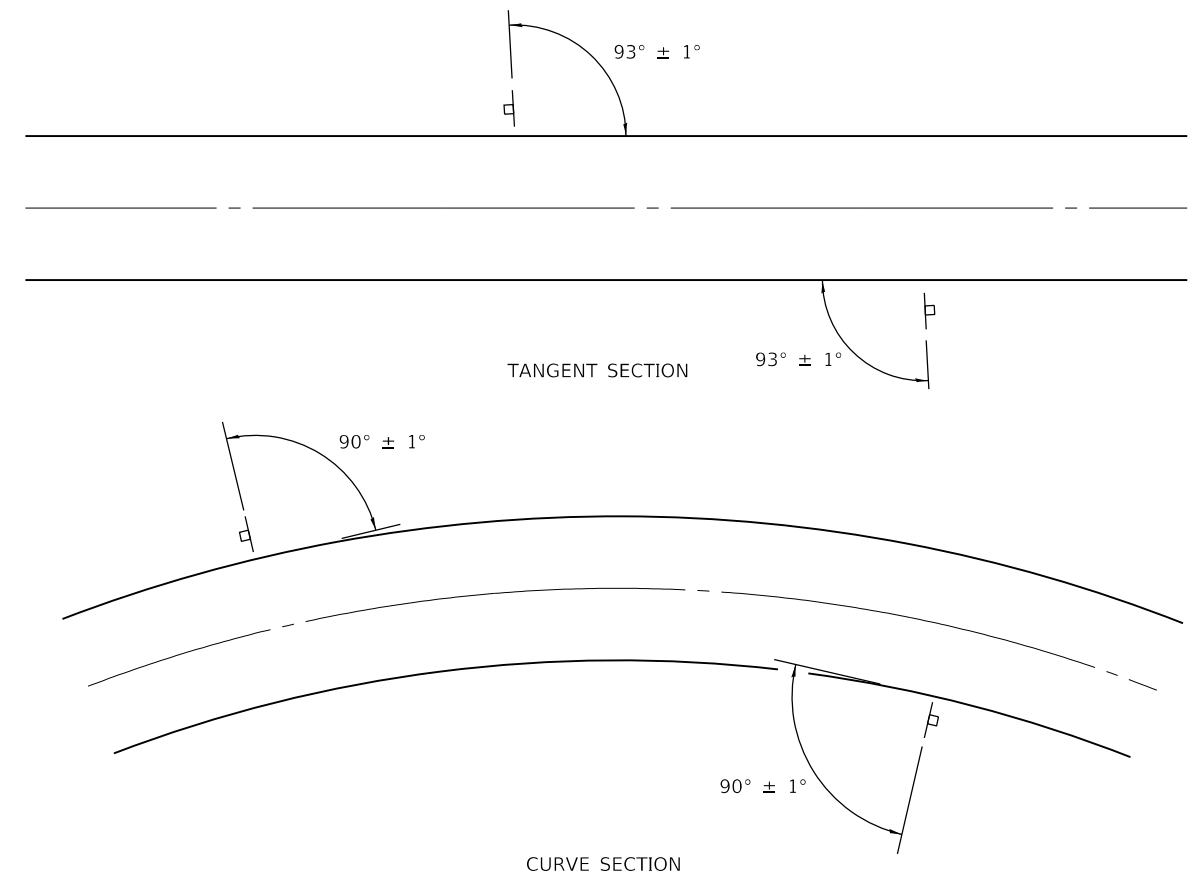

GROUND MOUNT SIGN POSITIONING

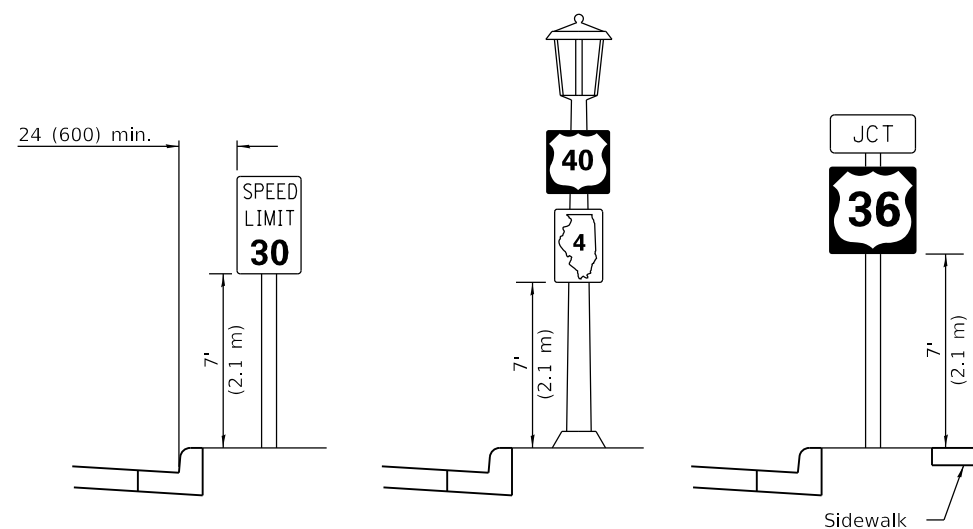

URBAN LOCATIONS

TYPICAL INSTALLATIONS

Signs in any area shall be erected to a uniform height above the edge of the pavement.

All dimensions are in inches (millimeters) unless otherwise shown.

Illinois Department of Transportation

PASSED January 1, 2014
Justin Mann
 ENGINEER OF OPERATIONS

APPROVED January 1, 2014
[Signature]
 ENGINEER OF DESIGN AND ENVIRONMENT

ISSUED 1-1-97

DATE	REVISIONS
1-1-14	Added shoulders and slopes.
	Changed sign distances from roadway and shoulder.
1-1-12	Rev. sign elev. for multilane hwy's. Revised sign elev. and dist. to curb for rural loc.

**SIGN PANEL
ERECTION DETAILS**

STANDARD 720006-04

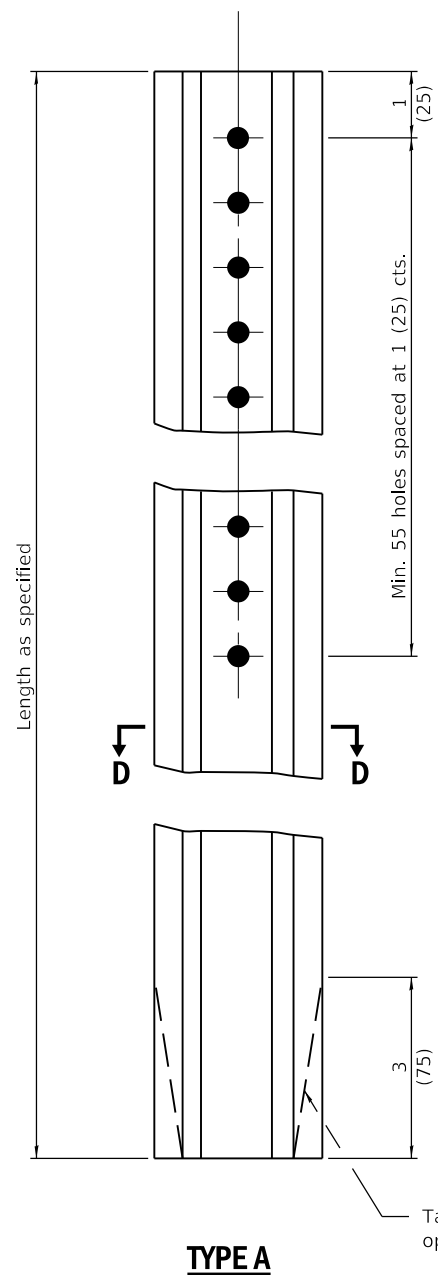

TYPE A

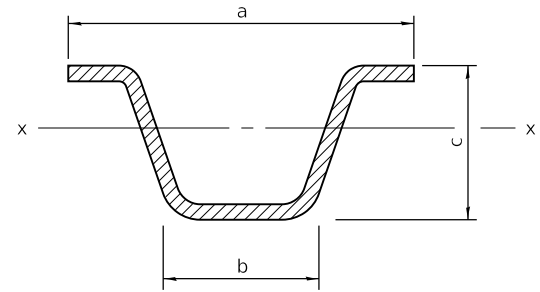

SECTION D-D

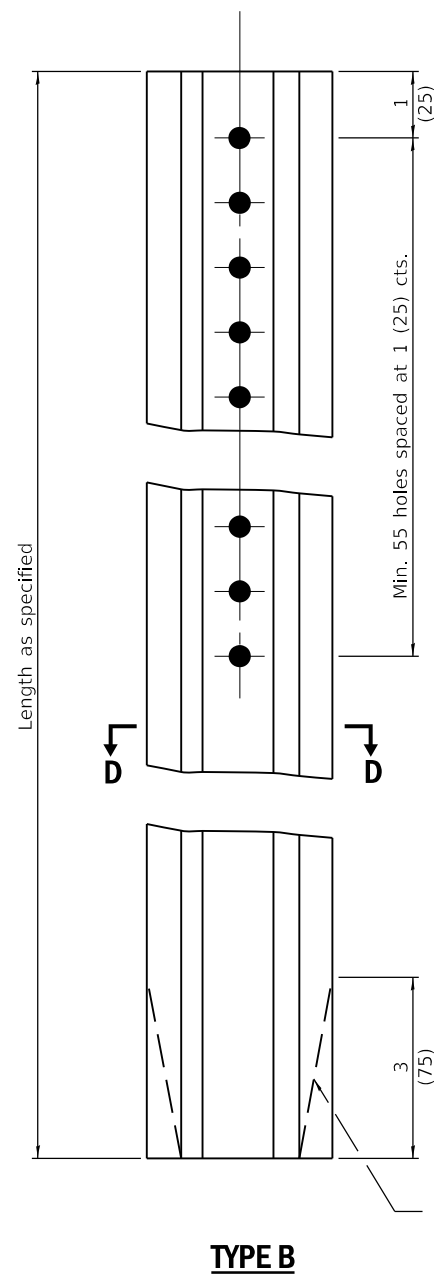

TYPE B

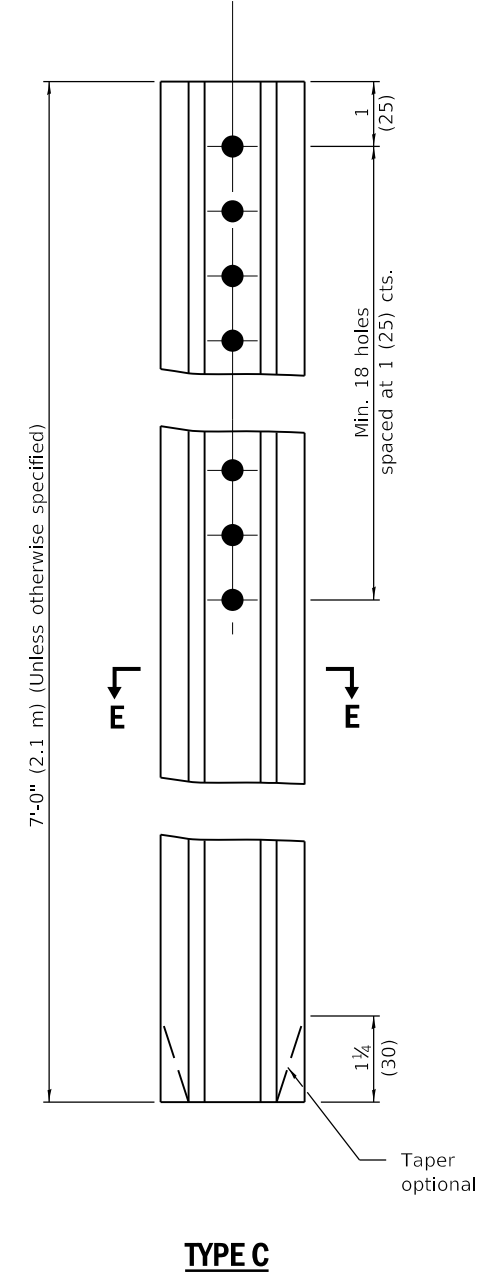

TYPE C

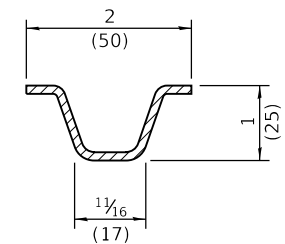

SECTION E-E

Steel - 1.12 lbs./ft. (1.67 kg/m)

		a	b	c	Sx-x in. ³ (mm ³)	lbs./ft. (kg/m)
TYPE A	Steel	3 1/16 (78)	1 1/2 (32)	1 1/16 (37)	0.223 (3,654)	2.00 (2.98)
	Aluminum	3 1/2 (89)	1 1/2 (41)	1 1/2 (48)	0.435 (7,128)	0.90 (1.34)
TYPE B	Steel	3 3/16 (81)	1 1/2 (32)	1 1/2 (38)	0.341 (5,588)	3.00 (4.46)
	Aluminum	4 3/8 (118)	2 1/2 (57)	2 3/8 (60)	0.888 (14,552)	1.30 (1.93)

GENERAL NOTES

Dimensions shown for cross sections are minimum.

All holes are 3/8 (10).

Sx-x is the minimum section modulus about the x-x axis of the post as shown. For posts in which holes are punched or drilled for more than half their length, Sx-x shall be computed for the net section.

All dimensions are in inches (millimeters) unless otherwise shown.

DATE	REVISIONS
1-1-09	Switched units to English (metric).
1-1-97	Renum. Standard 2350-4.

**METAL POSTS FOR SIGNS,
MARKERS & DELINEATORS**

STANDARD 720011-01

Illinois Department of Transportation

PASSED January 1, 2009

ENGINEER OF POLICY AND PROCEDURES

APPROVED January 1, 2009

ENGINEER OF DESIGN AND ENVIRONMENT

ISSUED 1-1-97