

DETAILS OF MAILBOX TURNOUTS

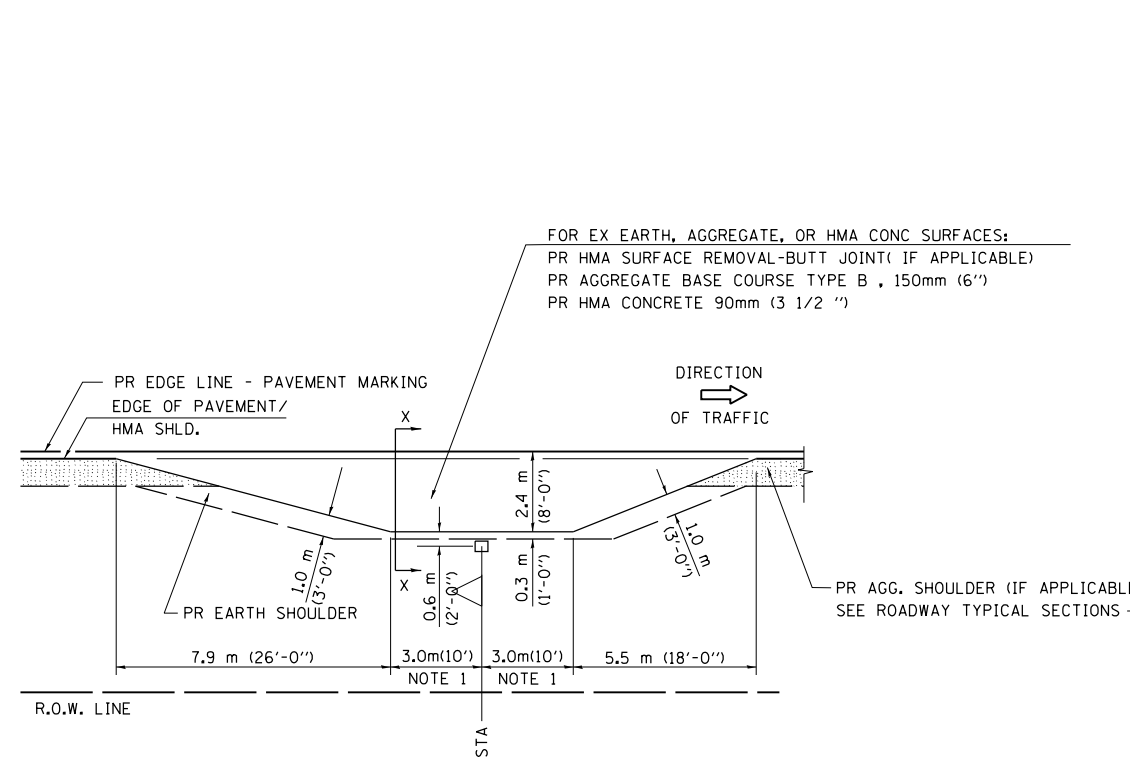

PLAN - MAILBOX TURNOUTS

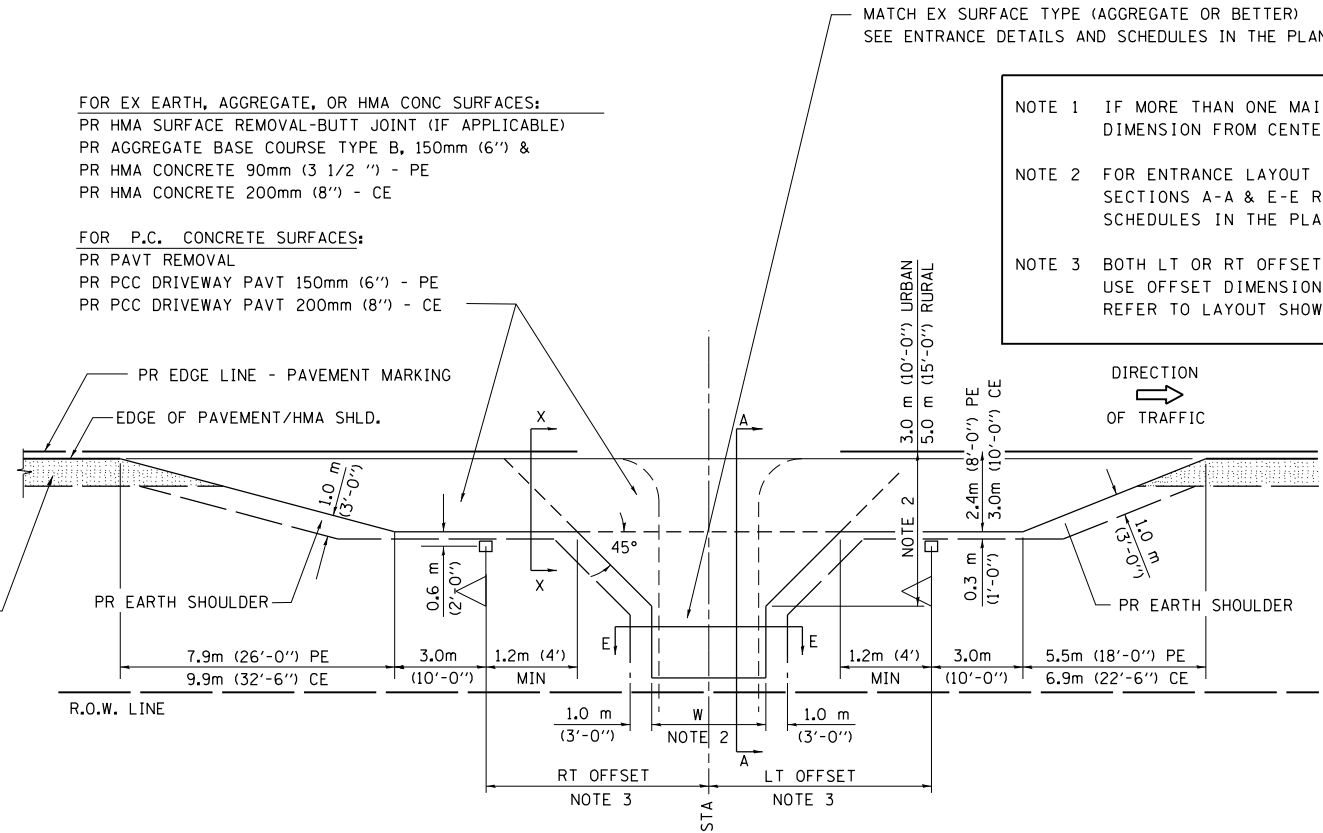

PLAN - COMBINED MAILBOX TURNOUT WITH TRAILING OR LEADING ENTRANCE

NOTE 1 IF MORE THAN ONE MAILBOX IS PRESENT, DIMENSION FROM CENTER OF END MAILBOX.

NOTE 2 FOR ENTRANCE LAYOUT DIMENSIONS AND SECTIONS A-A & E-E REFER TO THE SCHEDULES IN THE PLANS.

NOTE 3 BOTH LT OR RT OFFSETS FOR MAILBOX SHOWN USE OFFSET DIMENSION PER SCHEDULE AND REFER TO LAYOUT SHOWN ON THE PLAN.

FOR EX EARTH, AGGREGATE, OR HMA CONC SURFACES:
 PR HMA SURFACE REMOVAL-BUTT JOINT (IF APPLICABLE)
 PR AGGREGATE BASE COURSE TYPE B, 150mm (6") &
 PR HMA CONCRETE 90mm (3 1/2 ") - PE
 PR HMA CONCRETE 200mm (8") - CE

FOR P.C. CONCRETE SURFACES:
 PR PAVT REMOVAL
 PR PCC DRIVEWAY PAVT 150mm (6") - PE
 PR PCC DRIVEWAY PAVT 200mm (8") - CE

FOR EX EARTH, AGGREGATE, OR HMA CONC SURFACES:
 PR HMA SURFACE REMOVAL-BUTT JOINT (IF APPLICABLE)
 PR AGGREGATE BASE COURSE TYPE B, 150mm (6")
 PR HMA CONCRETE 90mm (3 1/2 ")

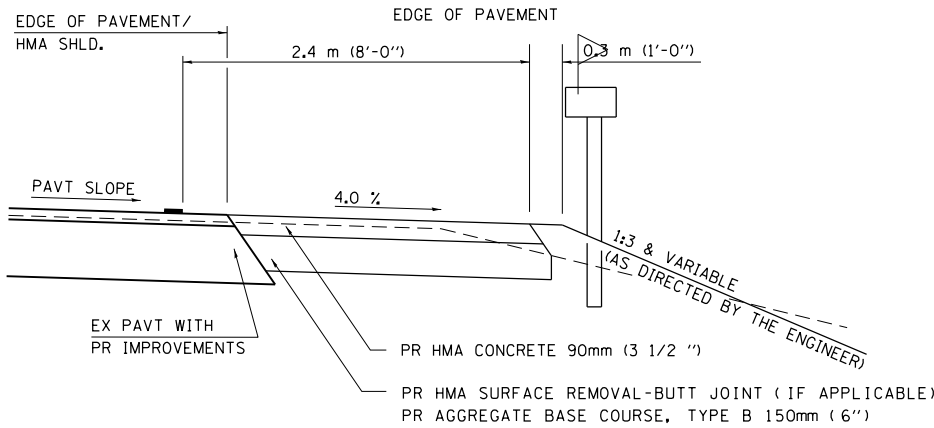

**SECTION X-X THRU MAILBOX TURNOUT
 ALSO APPLIES TO MAILBOX TURNOUTS COMBINED WITH
 EX EARTH, AGGREGATE, OR HMA PE & FE**

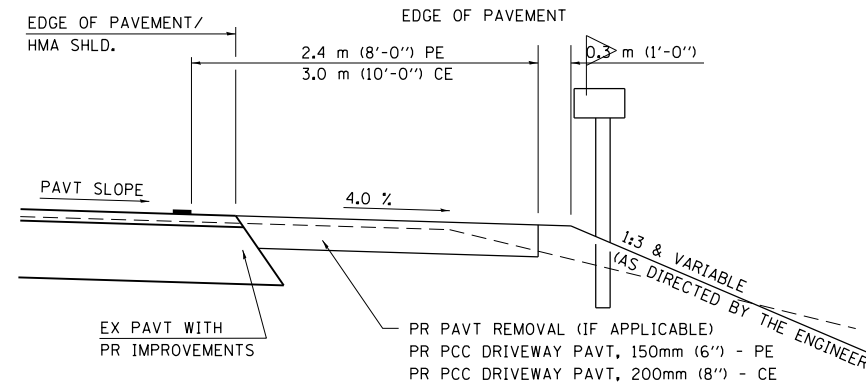

**SECTION X-X THRU MAILBOX TURNOUT
 COMBINED WITH EX CONC PE OR CE**

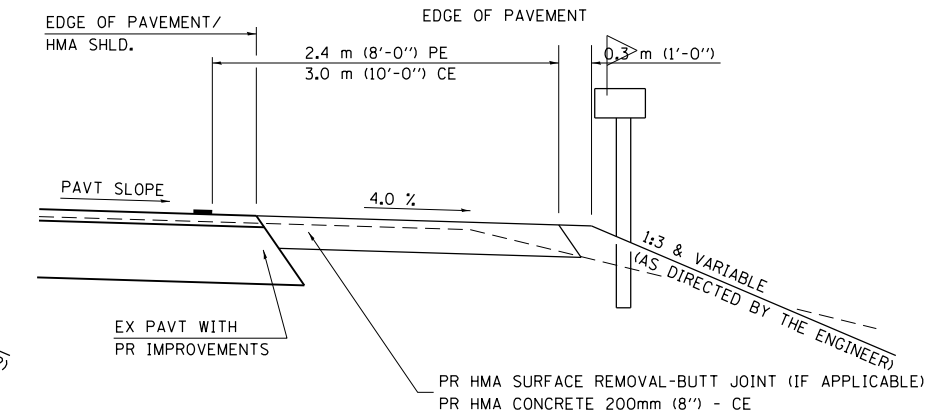

**SECTION X-X THRU MAILBOX TURNOUT
 COMBINED WITH EX EARTH, AGGREGATE, OR HMA CE**

FILE NAME =	USER NAME = sparksgw	DESIGNED -	REVISED - 2/19/03 (JCN)
et:\pw\work\p\id\sparksgw\0325252\d672\19-shr-034-ent-detail.dgn		DRAWN - CADD	REVISED - 4/01/04 (JCN)
	PLOT SCALE = 40.000' / in.	CHECKED - JCN	REVISED - 8/01/07 (JCN)
	PLOT DATE = Oct-19-2012 02:14:28PM	DATE - FEBRUARY 23, 1999	REVISED -

**STATE OF ILLINOIS
 DEPARTMENT OF TRANSPORTATION**

**DISTRICT 6 DETAILS FOR RURAL/URBAN ENTRANCE &
 MAILBOX TURNOUT W/O CONC GUTTER (3R - PROJECTS)**

SCALE: SHEET NO. 2 OF 2 SHEETS STA. TO STA.

F.A.P. RTE.	SECTION	COUNTY	TOTAL SHEETS	SHEET NO.
325	116BR-1	MACOUPIN	67	35
CONTRACT NO. 72A19				
FED. ROAD DIST. NO. ILLINOIS FED. AID PROJECT				

ENT 3R.DGN