

EAST EDGE OF SHOULDER

Location	Station	Offset	Theoretical Grade Elevations
N. End North Appr. Pvmf.	1740+71.30	-16.00	660.05
A1	1740+81.30	-16.00	660.09
A2	1740+91.30	-16.00	660.12
S. End North Appr. Pvmf.	1741+01.30	-16.00	660.15

EAST EDGE OF PAVEMENT

Location	Station	Offset	Theoretical Grade Elevations
N. End North Appr. Pvmf.	1740+67.57	-12.00	660.11
A1	1740+77.57	-12.00	660.16
A2	1740+87.57	-12.00	660.19
S. End North Appr. Pvmf.	1740+97.57	-12.00	660.23

CL ROADWAY & PROFILE GRADE LINE

Location	Station	Offset	Theoretical Grade Elevations
N. End North Appr. Pvmf.	1740+56.38	0.00	660.24
A1	1740+66.38	0.00	660.29
A2	1740+76.38	0.00	660.34
S. End North Appr. Pvmf.	1740+86.38	0.00	660.38

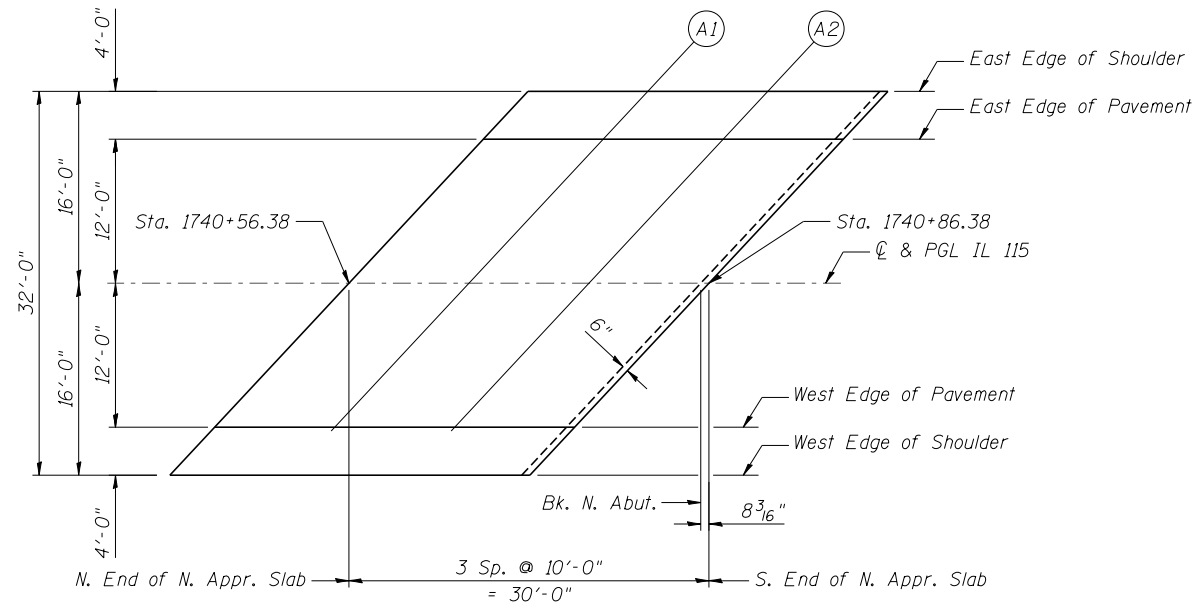

PLAN



WEST EDGE OF PAVEMENT

Location	Station	Offset	Theoretical Grade Elevations
N. End North Appr. Pvmf.	1740+45.19	12.00	660.00
A1	1740+55.19	12.00	660.05
A2	1740+65.19	12.00	660.10
S. End North Appr. Pvmf.	1740+75.19	12.00	660.15

WEST EDGE OF SHOULDER

Location	Station	Offset	Theoretical Grade Elevations
N. End North Appr. Pvmf.	1740+41.46	16.00	659.89
A1	1740+51.46	16.00	659.95
A2	1740+61.46	16.00	660.00
S. End North Appr. Pvmf.	1740+71.46	16.00	660.05

NORTH APPROACH SLAB ELEVATIONS
STRUCTURE NO. 027-0072

FILE NAME = ...665980-SN0270072-004-NApprSlabElev.dgn



Zroka Engineering, P.C.
4216 North Hermitage
Chicago, IL 60613

USER NAME = SAW	DESIGNED - LAS	REVISED -
	CHECKED - DAZ	REVISED -
PLOT SCALE = 0:2.0000 ' : ' / IN.	DRAWN - SAW	REVISED -
PLOT DATE = 10/30/2012	CHECKED - LAS	REVISED -

STATE OF ILLINOIS
DEPARTMENT OF TRANSPORTATION

NORTH APPROACH SLAB ELEVATIONS
S.N. 027-0072

SHEET NO. SA-04 OF SA-15 SHEETS

F.A.P. RTE.	SECTION	COUNTY	TOTAL SHEETS	SHEET NO.
796	(106 BR-1 & BR-4)BR	FORD	78	36
CONTRACT NO. 66980				
ILLINOIS FED. AID PROJECT				