

**EROSION CONTROL LEGEND**

	TEMPORARY EROSION CONTROL SEEDING AND TEMPORARY EROSION CONTROL BLANKET		TEMPORARY DITCH CHECK
	PERMANENT SEEDING (SEE NOTE 3)		TEMPORARY DITCH CHECK INSTALLED IN PREVIOUS STAGE
	TEMPORARY EROSION CONTROL SEEDING OR PERMANENT SEEDING INSTALLED IN A PREVIOUS STAGE		INLET & PIPE PROTECTION
	TEMPORARY PAVEMENT		INLET & PIPE PROTECTION INSTALLED IN PREVIOUS STAGE
	PERIMETER EROSION BARRIER (SEE NOTE 2)		FLOW DIRECTION (SEE NOTE 4)
	PERIMETER EROSION BARRIER INSTALLED IN PREVIOUS STAGE		PROPOSED STORM SEWER (SEE NOTE 1)
	INLET FILTER		PROPOSED STORM SEWER INSTALLED IN PREVIOUS STAGE
	INLET FILTER INSTALLED IN PREVIOUS STAGE		TEMPORARY PIPE CULVERT
	PERMANENT DRAINAGE STRUCTURE NUMBER (SEE NOTE 1)		

**NOTES**

1. SEE PROPOSED DRAINAGE PLANS FOR STORM SEWER INFORMATION
2. PERIMETER EROSION BARRIER SHALL BE ERECTED ADJACENT TO R.O.W., EASEMENT, AND CONSTRUCTION LIMITS AND AS DIRECTED BY THE ENGINEER.
3. SEE LANDSCAPING PLANS FOR LANDSCAPING REQUIREMENTS.
4. SEE STAGE 1 CROSS SECTIONS FOR GRADING INFORMATION.

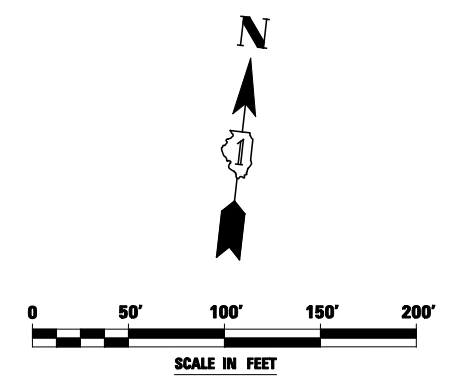

FILE NAME = #FILE#	USER NAME = #USER#	DESIGNED <i>PJO</i>	REVISED -	<b>STATE OF ILLINOIS DEPARTMENT OF TRANSPORTATION</b>	<b>EROSION CONTROL - STAGE 1, 1A, AND 1B RAMP D</b>	F.A.P. RTE.	SECTION	COUNTY	TOTAL SHEETS	SHEET NO.	
		DRAWN <i>KES</i>	REVISED -			338	(112 & 113) WRS-5	DUPAGE	963	501	
		CHECKED <i>JCM</i>	REVISED -			CONTRACT NO. 60I31					
		DATE <i>10/15/2012</i>	REVISED -			ILLINOIS FED. AID PROJECT					
				SCALE:	SHEET NO. 26 OF 66 SHEETS	STA. 1981+22	TO STA. 1995+50				

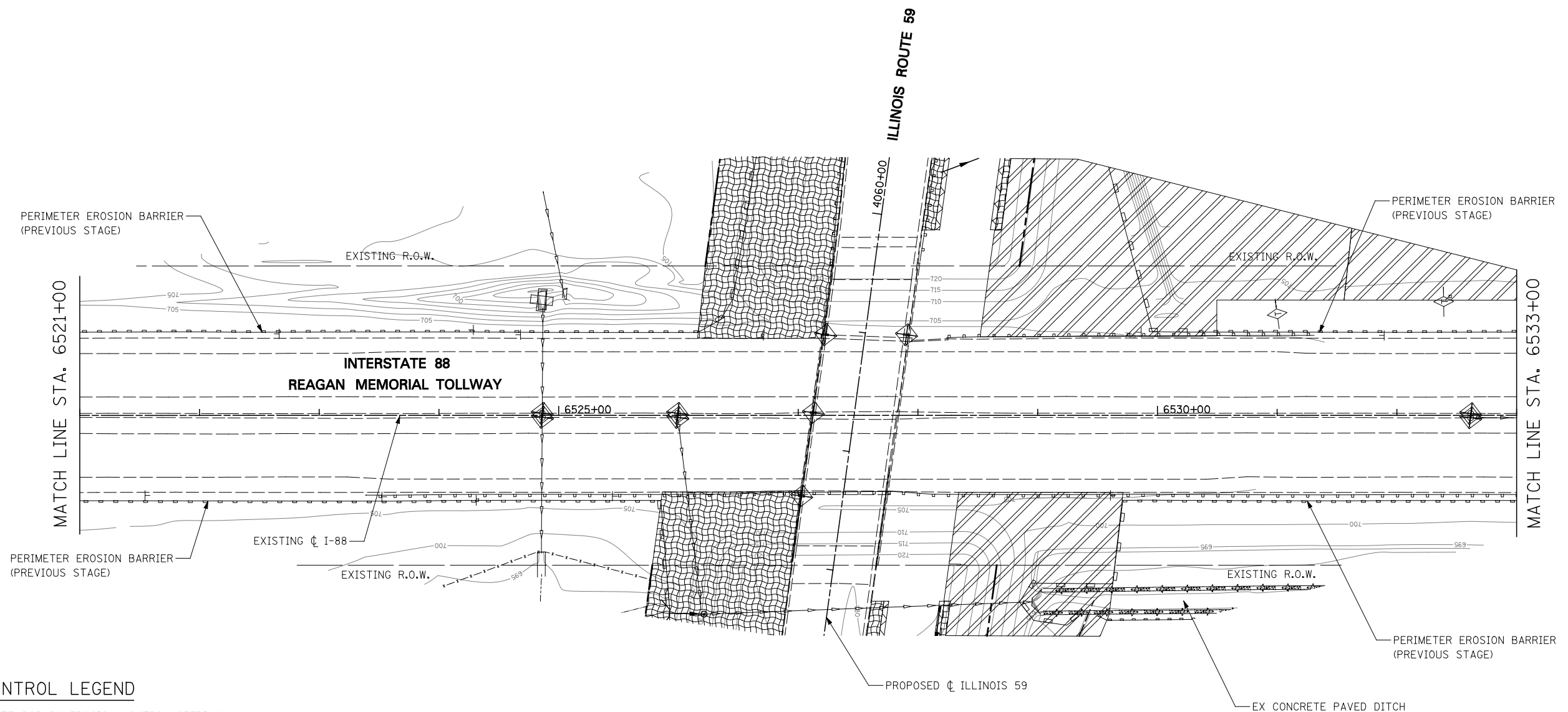

**EROSION CONTROL LEGEND**

- |  |                                                                                      |  |                                                     |
|--|--------------------------------------------------------------------------------------|--|-----------------------------------------------------|
|  | TEMPORARY EROSION CONTROL SEEDING AND TEMPORARY EROSION CONTROL BLANKET              |  | TEMPORARY DITCH CHECK                               |
|  | PERMANENT SEEDING (SEE NOTE 3)                                                       |  | TEMPORARY DITCH CHECK INSTALLED IN PREVIOUS STAGE   |
|  | TEMPORARY EROSION CONTROL SEEDING OR PERMANENT SEEDING INSTALLED IN A PREVIOUS STAGE |  | INLET & PIPE PROTECTION                             |
|  | TEMPORARY PAVEMENT                                                                   |  | INLET & PIPE PROTECTION INSTALLED IN PREVIOUS STAGE |
|  | PERIMETER EROSION BARRIER (SEE NOTE 2)                                               |  | FLOW DIRECTION (SEE NOTE 4)                         |
|  | PERIMETER EROSION BARRIER INSTALLED IN PREVIOUS STAGE                                |  | PROPOSED STORM SEWER (SEE NOTE 1)                   |
|  | INLET FILTER                                                                         |  | PROPOSED STORM SEWER INSTALLED IN PREVIOUS STAGE    |
|  | INLET FILTER INSTALLED IN PREVIOUS STAGE                                             |  | TEMPORARY PIPE CULVERT                              |
|  | PERMANENT DRAINAGE STRUCTURE NUMBER (SEE NOTE 1)                                     |  |                                                     |

**NOTES**

- SEE PROPOSED DRAINAGE PLANS FOR STORM SEWER INFORMATION
- PERIMETER EROSION BARRIER SHALL BE ERECTED ADJACENT TO R.O.W., EASEMENT, AND CONSTRUCTION LIMITS AND AS DIRECTED BY THE ENGINEER.
- SEE LANDSCAPING PLANS FOR LANDSCAPING REQUIREMENTS.
- SEE STAGE 1 CROSS SECTIONS FOR GRADING INFORMATION.

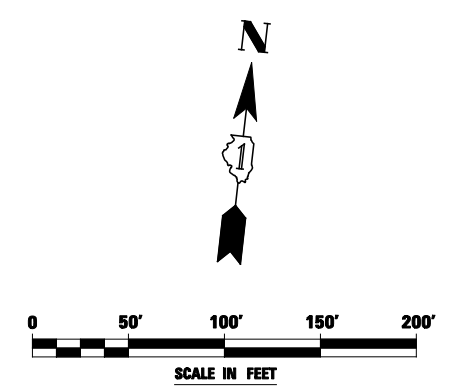

FILE NAME = #FILE#	USER NAME = #USER#	DESIGNED <i>PJO</i>	REVISED -	<b>STATE OF ILLINOIS DEPARTMENT OF TRANSPORTATION</b>	<b>EROSION CONTROL - STAGE 1, 1A, AND 1B INTERSTATE 88</b>	F.A.P. RTE.	SECTION	COUNTY	TOTAL SHEETS	SHEET NO.	
		DRAWN <i>KES</i>	REVISED -			338	(112 & 113) WRS-5	DUPAGE	963	502	
		CHECKED <i>JCM</i>	REVISED -			CONTRACT NO. 60I31					
		DATE <i>10/15/2012</i>	REVISED -			ILLINOIS FED. AID PROJECT					
				SCALE:	SHEET NO. 27 OF 66 SHEETS	STA. 6521+00 TO STA. 6533+00					

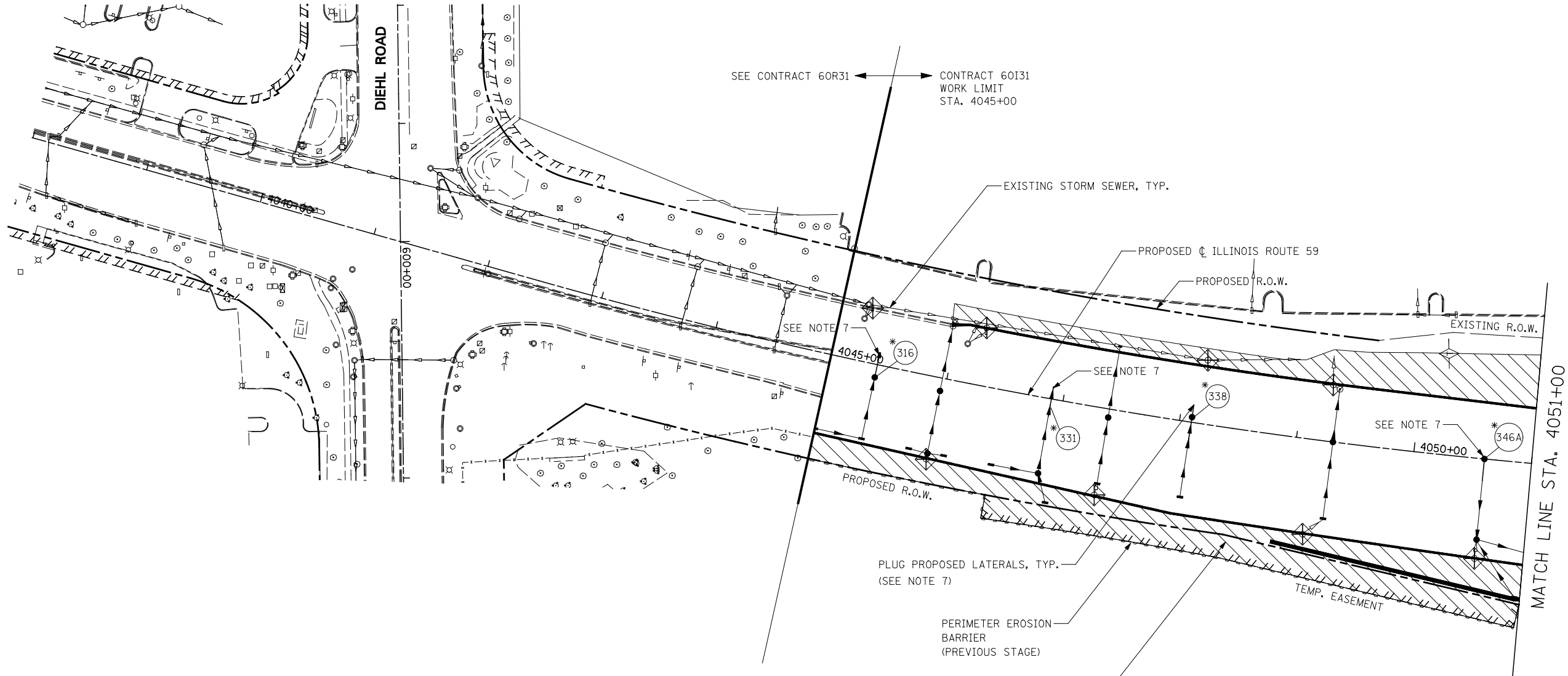

SEE CONTRACT 60R31 ← CONTRACT 60I31  
WORK LIMIT  
STA. 4045+00

MATCH LINE STA. 4051+00

**EROSION CONTROL LEGEND**

- |  |                                                                                      |  |                                                     |
|--|--------------------------------------------------------------------------------------|--|-----------------------------------------------------|
|  | TEMPORARY EROSION CONTROL SEEDING AND TEMPORARY EROSION CONTROL BLANKET              |  | TEMPORARY DITCH CHECK                               |
|  | PERMANENT SEEDING (SEE NOTE 3)                                                       |  | TEMPORARY DITCH CHECK INSTALLED IN PREVIOUS STAGE   |
|  | TEMPORARY EROSION CONTROL SEEDING OR PERMANENT SEEDING INSTALLED IN A PREVIOUS STAGE |  | INLET & PIPE PROTECTION                             |
|  | TEMPORARY PAVEMENT                                                                   |  | INLET & PIPE PROTECTION INSTALLED IN PREVIOUS STAGE |
|  | PERIMETER EROSION BARRIER (SEE NOTE 2)                                               |  | FLOW DIRECTION (SEE NOTE 4)                         |
|  | PERIMETER EROSION BARRIER INSTALLED IN PREVIOUS STAGE                                |  | PROPOSED STORM SEWER (SEE NOTE 1)                   |
|  | INLET FILTER                                                                         |  | PROPOSED STORM SEWER INSTALLED IN PREVIOUS STAGE    |
|  | INLET FILTER INSTALLED IN PREVIOUS STAGE                                             |  | TEMPORARY PIPE CULVERT                              |
|  | PERMANENT DRAINAGE STRUCTURE NUMBER (SEE NOTE 1)                                     |  |                                                     |
- (\*) - SEE NOTE 5

**NOTES**

- SEE PROPOSED DRAINAGE PLANS FOR STORM SEWER INFORMATION
- PERIMETER EROSION BARRIER SHALL BE ERECTED ADJACENT TO R.O.W., EASEMENT, AND CONSTRUCTION LIMITS AND AS DIRECTED BY THE ENGINEER.
- SEE LANDSCAPING PLANS FOR LANDSCAPING REQUIREMENTS.
- SEE STAGE 2 CROSS SECTIONS FOR GRADING INFORMATION.
- PROPOSED STRUCTURE SHALL BE BURIED AND TEMPORARILY COVERED/CLOSED WITH STEEL PLATE OF THICKNESS SPECIFIED AND APPROVED BY THE ENGINEER. PAYMENT FOR THIS TEMPORARY COVER INSTALLATION AND REMOVAL SHALL BE CONSIDERED INCLUDED IN THE COST OF THE PROPOSED STRUCTURE.
- WHEN TEMPORARY OR PERMANENT STORM SEWER IS TO BE PLACED BELOW EXISTING PAVEMENT OR TEMPORARY PAVEMENT, THE EXISTING PAVEMENT OR TEMPORARY PAVEMENT WITHIN THE LIMITS OF THE TRENCHING OPERATION, SHALL BE REMOVED AND REPLACED. PAID FOR AS "CLASS D PATCHES, TYPE III, 15 INCH (SPECIAL)".

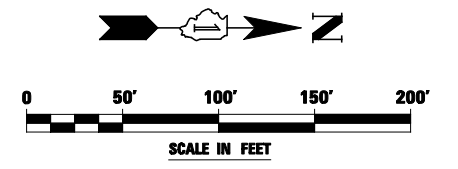

FILE NAME =	USER NAME = #USER#	DESIGNED <i>PJO</i>	REVISED -
#FILE#		DRAWN <i>KES</i>	REVISED -
	PLOT SCALE = #SCALE#	CHECKED <i>JCM</i>	REVISED -
	PLOT DATE = #DATE#	DATE <i>10/15/2012</i>	REVISED -

**STATE OF ILLINOIS  
DEPARTMENT OF TRANSPORTATION**

**EROSION CONTROL - STAGE 2  
IL ROUTE 59**

SCALE: SHEET NO. 28 OF 66 SHEETS STA. 4045+00 TO STA. 4051+00

F.A.P. RTE.	SECTION	COUNTY	TOTAL SHEETS	SHEET NO.
338	(112 & 113) WRS-5	DUPAGE	963	503
CONTRACT NO. 60I31				
ILLINOIS FED. AID PROJECT				

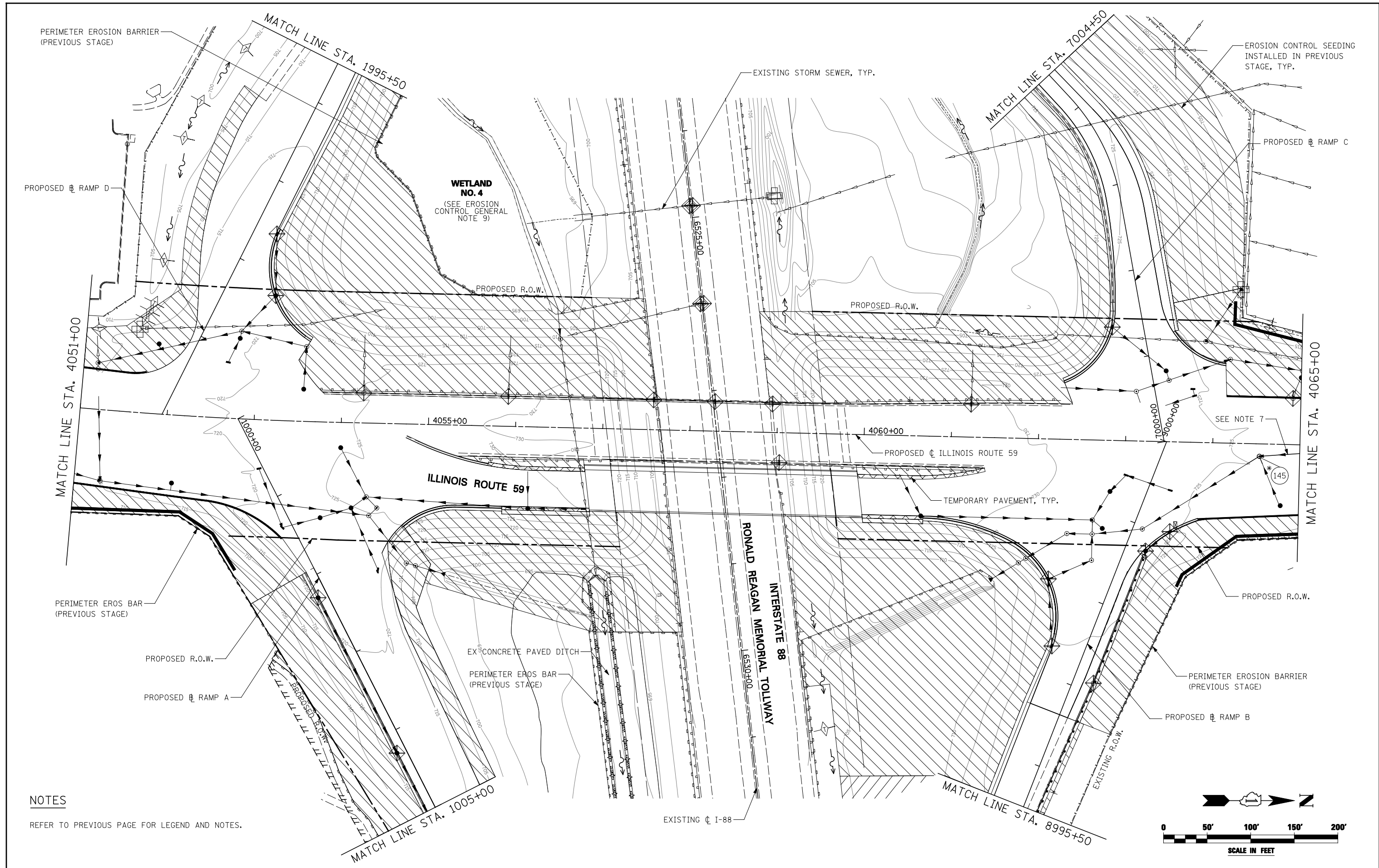

**NOTES**

REFER TO PREVIOUS PAGE FOR LEGEND AND NOTES.

FILE NAME = #FILE#	USER NAME = #USER#	DESIGNED <i>PJO</i>	REVISED -
		DRAWN <i>KES</i>	REVISED -
		CHECKED <i>JCM</i>	REVISED -
		DATE <i>10/15/2012</i>	REVISED -

**STATE OF ILLINOIS  
DEPARTMENT OF TRANSPORTATION**

**EROSION CONTROL - STAGE 2  
ILLINOIS ROUTE 59**

SCALE: SHEET NO. 29 OF 66 SHEETS STA. 4051+00 TO STA. 4065+00

F.A.P. RTE.	SECTION	COUNTY	TOTAL SHEETS	SHEET NO.
338	(112 & 113) WRS-5	DUPAGE	963	504
CONTRACT NO. 60131				
ILLINOIS FED. AID PROJECT				

**EROSION CONTROL LEGEND**

- |  |                                                                                      |  |                                                     |
|--|--------------------------------------------------------------------------------------|--|-----------------------------------------------------|
|  | TEMPORARY EROSION CONTROL SEEDING AND TEMPORARY EROSION CONTROL BLANKET              |  | TEMPORARY DITCH CHECK                               |
|  | PERMANENT SEEDING (SEE NOTE 3)                                                       |  | TEMPORARY DITCH CHECK INSTALLED IN PREVIOUS STAGE   |
|  | TEMPORARY EROSION CONTROL SEEDING OR PERMANENT SEEDING INSTALLED IN A PREVIOUS STAGE |  | INLET & PIPE PROTECTION                             |
|  | TEMPORARY PAVEMENT                                                                   |  | INLET & PIPE PROTECTION INSTALLED IN PREVIOUS STAGE |
|  | PERIMETER EROSION BARRIER (SEE NOTE 2)                                               |  | FLOW DIRECTION (SEE NOTE 4)                         |
|  | PERIMETER EROSION BARRIER INSTALLED IN PREVIOUS STAGE                                |  | PROPOSED STORM SEWER (SEE NOTE 1)                   |
|  | INLET FILTER                                                                         |  | PROPOSED STORM SEWER INSTALLED IN PREVIOUS STAGE    |
|  | INLET FILTER INSTALLED IN PREVIOUS STAGE                                             |  | TEMPORARY PIPE CULVERT                              |
|  | PERMANENT DRAINAGE STRUCTURE NUMBER (SEE NOTE 1)                                     |  | (* ) - SEE NOTE 5                                   |

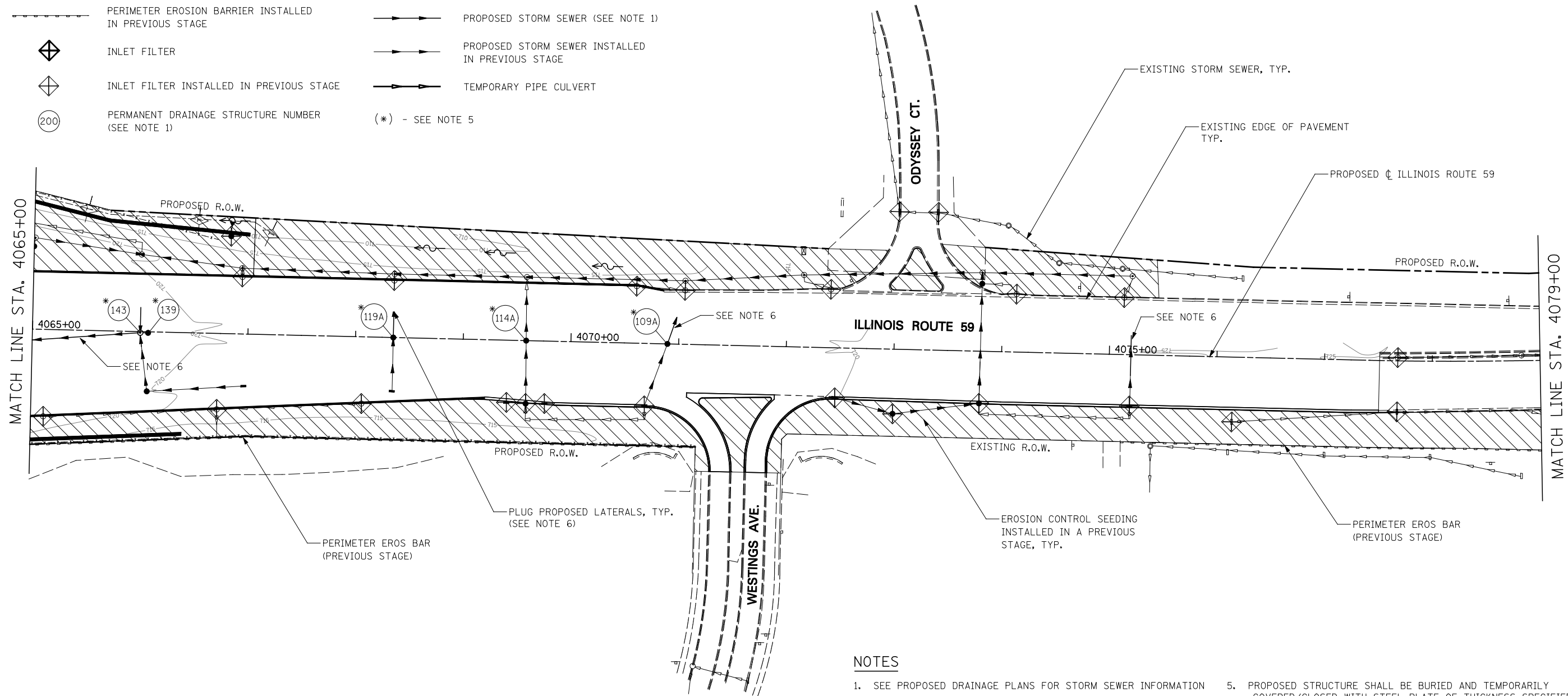
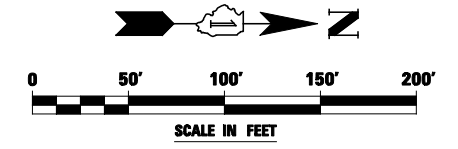

**NOTES**

- SEE PROPOSED DRAINAGE PLANS FOR STORM SEWER INFORMATION
- PERIMETER EROSION BARRIER SHALL BE ERECTED ADJACENT TO R.O.W., EASEMENT, AND CONSTRUCTION LIMITS AND AS DIRECTED BY THE ENGINEER.
- SEE LANDSCAPING PLANS FOR LANDSCAPING REQUIREMENTS.
- SEE STAGE 2 CROSS SECTIONS FOR GRADING INFORMATION.
- PROPOSED STRUCTURE SHALL BE BURIED AND TEMPORARILY COVERED/CLOSED WITH STEEL PLATE OF THICKNESS SPECIFIED AND APPROVED BY THE ENGINEER. PAYMENT FOR THIS TEMPORARY COVER INSTALLATION AND REMOVAL SHALL BE CONSIDERED INCLUDED IN THE COST OF THE PROPOSED STRUCTURE.
- WHEN TEMPORARY OR PERMANENT STORM SEWER IS TO BE PLACED BELOW EXISTING PAVEMENT OR TEMPORARY PAVEMENT, THE EXISTING PAVEMENT OR TEMPORARY PAVEMENT WITHIN THE LIMITS OF THE TRENCHING OPERATION, SHALL BE REMOVED AND REPLACED. PAID FOR AS "CLASS D PATCHES, TYPE III, 15 INCH (SPECIAL)".

FILE NAME = #FILE#	USER NAME = #USER#	DESIGNED <i>PJO</i>	REVISED -	<b>STATE OF ILLINOIS DEPARTMENT OF TRANSPORTATION</b>	<b>EROSION CONTROL - STAGE 2 ILLINOIS ROUTE 59</b>		F.A.P. RTE.	SECTION	COUNTY	TOTAL SHEETS	SHEET NO.	
		DRAWN <i>KES</i>	REVISED -		SCALE:	SHEET NO. 30 OF 66 SHEETS	STA. 4065+00 TO STA. 4079+00	338	(112 & 113) WRS-5	DUPAGE	963	505
		CHECKED <i>JCM</i>	REVISED -		CONTRACT NO. 60131							
		DATE <i>10/15/2012</i>	REVISED -		ILLINOIS FED. AID PROJECT							

**EROSION CONTROL LEGEND**

	TEMPORARY EROSION CONTROL SEEDING AND TEMPORARY EROSION CONTROL BLANKET		TEMPORARY DITCH CHECK
	PERMANENT SEEDING (SEE NOTE 3)		TEMPORARY DITCH CHECK INSTALLED IN PREVIOUS STAGE
	TEMPORARY EROSION CONTROL SEEDING OR PERMANENT SEEDING INSTALLED IN A PREVIOUS STAGE		INLET & PIPE PROTECTION
	TEMPORARY PAVEMENT		INLET & PIPE PROTECTION INSTALLED IN PREVIOUS STAGE
	PERIMETER EROSION BARRIER (SEE NOTE 2)		FLOW DIRECTION (SEE NOTE 4)
	PERIMETER EROSION BARRIER INSTALLED IN PREVIOUS STAGE		PROPOSED STORM SEWER (SEE NOTE 1)
	INLET FILTER		PROPOSED STORM SEWER INSTALLED IN PREVIOUS STAGE
	INLET FILTER INSTALLED IN PREVIOUS STAGE		TEMPORARY PIPE CULVERT
	PERMANENT DRAINAGE STRUCTURE NUMBER (SEE NOTE 1)		

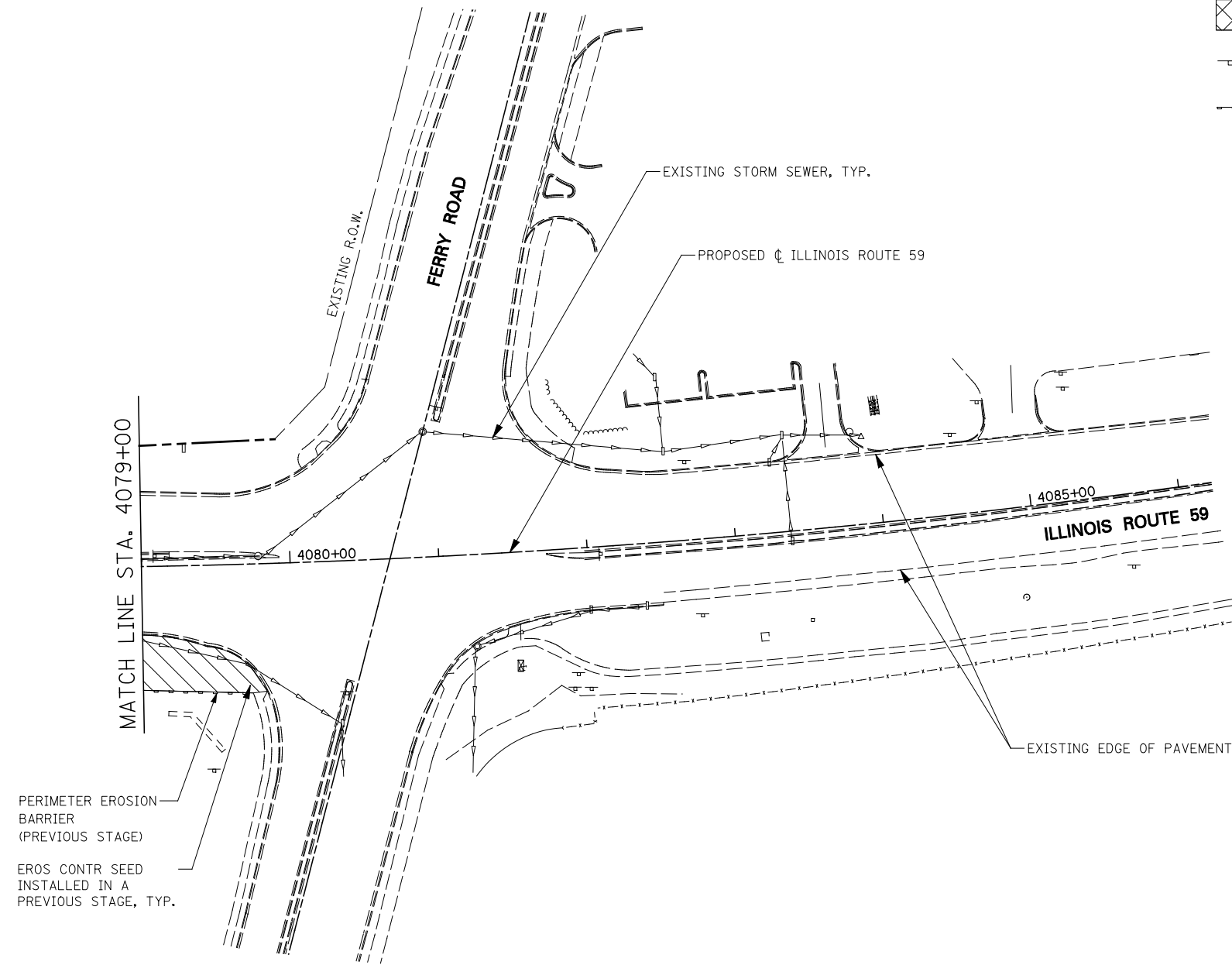

**NOTES**

1. SEE PROPOSED DRAINAGE PLANS FOR STORM SEWER INFORMATION
2. PERIMETER EROSION BARRIER SHALL BE ERECTED ADJACENT TO R.O.W., EASEMENT, AND CONSTRUCTION LIMITS AND AS DIRECTED BY THE ENGINEER.
3. SEE LANDSCAPING PLANS FOR LANDSCAPING REQUIREMENTS.
4. SEE STAGE 2 CROSS SECTIONS FOR GRADING INFORMATION.

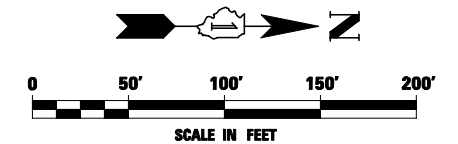

FILE NAME = #FILE#	USER NAME = #USER#	DESIGNED <i>PJO</i>	REVISED -	<b>STATE OF ILLINOIS DEPARTMENT OF TRANSPORTATION</b>	<b>EROSION CONTROL - STAGE 2 ILLINOIS ROUTE 59</b>	F.A.P. RTE.	SECTION	COUNTY	TOTAL SHEETS	SHEET NO.	
		DRAWN <i>KES</i>	REVISED -			338	(112 & 113) WRS-5	DUPAGE	963	506	
		CHECKED <i>JCM</i>	REVISED -			CONTRACT NO. 60I31					
		DATE <i>10/15/2012</i>	REVISED -			ILLINOIS FED. AID PROJECT					
					SCALE:	SHEET NO. 31 OF 66 SHEETS		STA. 4079+00 TO STA. 4086+00			

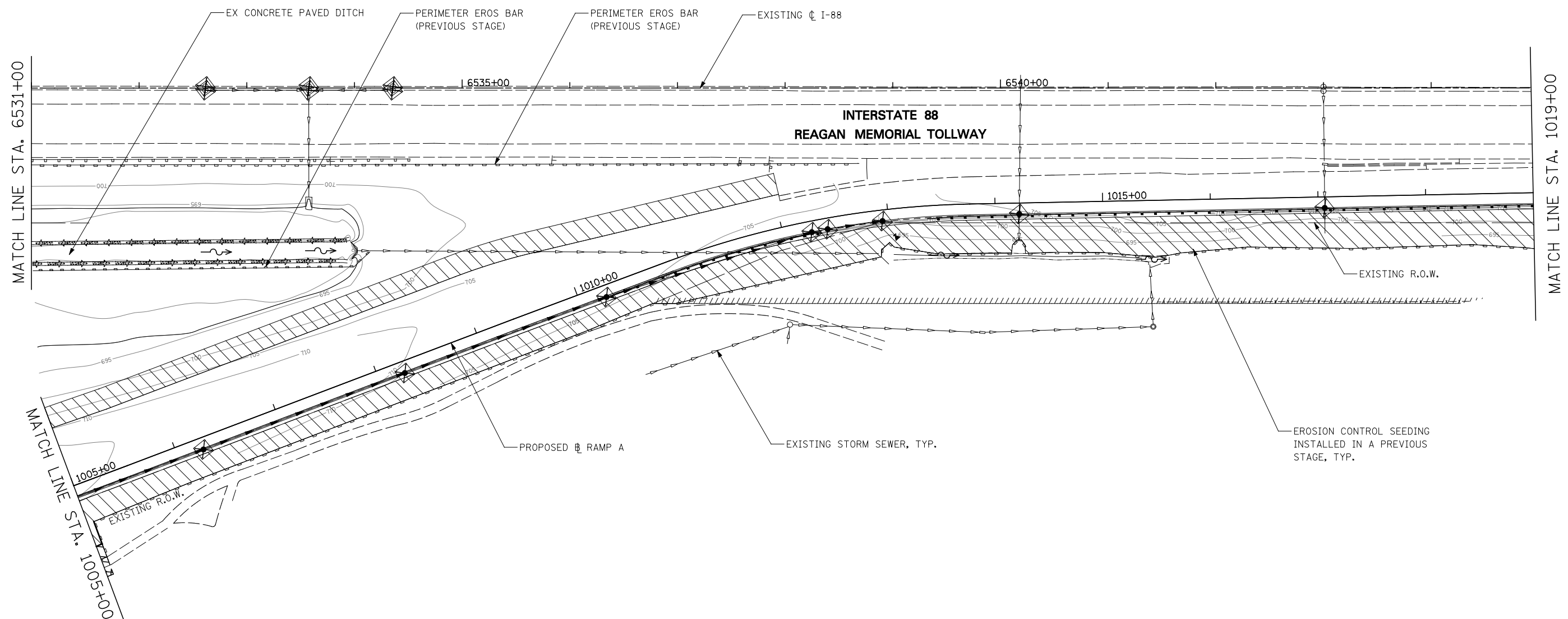

**EROSION CONTROL LEGEND**

	TEMPORARY EROSION CONTROL SEEDING AND TEMPORARY EROSION CONTROL BLANKET		TEMPORARY DITCH CHECK
	PERMANENT SEEDING (SEE NOTE 3)		TEMPORARY DITCH CHECK INSTALLED IN PREVIOUS STAGE
	TEMPORARY EROSION CONTROL SEEDING OR PERMANENT SEEDING INSTALLED IN A PREVIOUS STAGE		INLET & PIPE PROTECTION
	TEMPORARY PAVEMENT		INLET & PIPE PROTECTION INSTALLED IN PREVIOUS STAGE
	PERIMETER EROSION BARRIER (SEE NOTE 2)		FLOW DIRECTION (SEE NOTE 4)
	PERIMETER EROSION BARRIER INSTALLED IN PREVIOUS STAGE		PROPOSED STORM SEWER (SEE NOTE 1)
	INLET FILTER		PROPOSED STORM SEWER INSTALLED IN PREVIOUS STAGE
	INLET FILTER INSTALLED IN PREVIOUS STAGE		TEMPORARY PIPE CULVERT
	PERMANENT DRAINAGE STRUCTURE NUMBER (SEE NOTE 1)		

**NOTES**

- SEE PROPOSED DRAINAGE PLANS FOR STORM SEWER INFORMATION
- PERIMETER EROSION BARRIER SHALL BE ERECTED ADJACENT TO R.O.W., EASEMENT, AND CONSTRUCTION LIMITS AND AS DIRECTED BY THE ENGINEER.
- SEE LANDSCAPING PLANS FOR LANDSCAPING REQUIREMENTS.
- SEE STAGE 2 CROSS SECTIONS FOR GRADING INFORMATION.

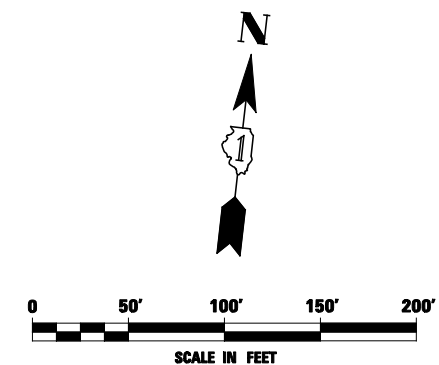

FILE NAME = #FILEL#	USER NAME = #USER#	DESIGNED <i>PJO</i>	REVISED -	<b>STATE OF ILLINOIS DEPARTMENT OF TRANSPORTATION</b>	<b>EROSION CONTROL - STAGE 2 RAMP A</b>		F.A.P. RTE.	SECTION	COUNTY	TOTAL SHEETS	SHEET NO.	
		DRAWN <i>KES</i>	REVISED -		SCALE:	SHEET NO. 32 OF 66 SHEETS	STA. 1005+00 TO STA. 1019+00	338	(112 & 113) WRS-5	DUPAGE	963	507
		CHECKED <i>JCM</i>	REVISED -		CONTRACT NO. 60I31							
		DATE <i>10/15/2012</i>	REVISED -		ILLINOIS FED. AID PROJECT							

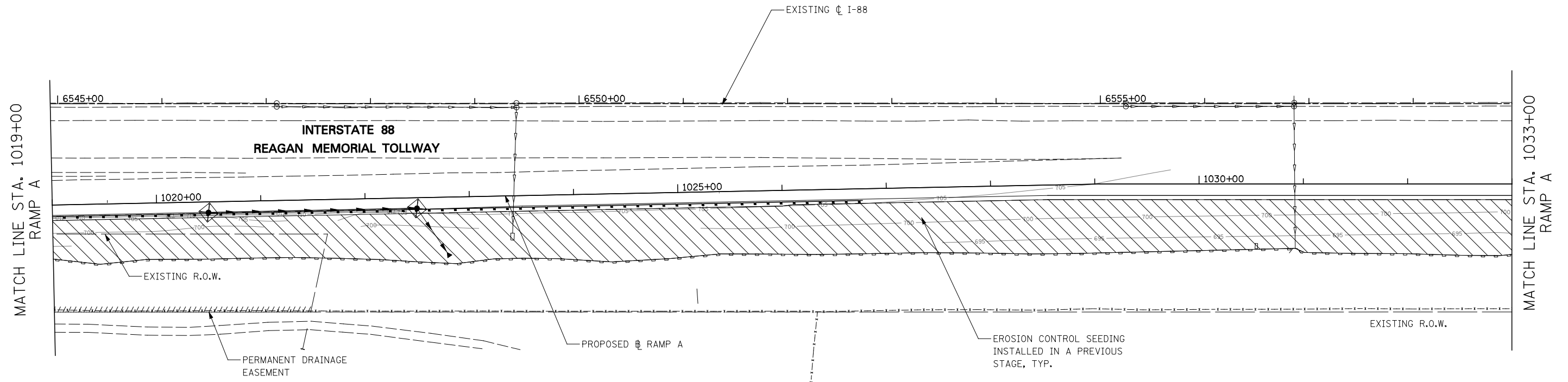

**EROSION CONTROL LEGEND**

	TEMPORARY EROSION CONTROL SEEDING AND TEMPORARY EROSION CONTROL BLANKET		TEMPORARY DITCH CHECK
	PERMANENT SEEDING (SEE NOTE 3)		TEMPORARY DITCH CHECK INSTALLED IN PREVIOUS STAGE
	TEMPORARY EROSION CONTROL SEEDING OR PERMANENT SEEDING INSTALLED IN A PREVIOUS STAGE		INLET & PIPE PROTECTION
	TEMPORARY PAVEMENT		INLET & PIPE PROTECTION INSTALLED IN PREVIOUS STAGE
	PERIMETER EROSION BARRIER (SEE NOTE 2)		FLOW DIRECTION (SEE NOTE 4)
	PERIMETER EROSION BARRIER INSTALLED IN PREVIOUS STAGE		PROPOSED STORM SEWER (SEE NOTE 1)
	INLET FILTER		PROPOSED STORM SEWER INSTALLED IN PREVIOUS STAGE
	INLET FILTER INSTALLED IN PREVIOUS STAGE		TEMPORARY PIPE CULVERT
	PERMANENT DRAINAGE STRUCTURE NUMBER (SEE NOTE 1)		

**NOTES**

1. SEE PROPOSED DRAINAGE PLANS FOR STORM SEWER INFORMATION
2. PERIMETER EROSION BARRIER SHALL BE ERECTED ADJACENT TO R.O.W., EASEMENT, AND CONSTRUCTION LIMITS AND AS DIRECTED BY THE ENGINEER.
3. SEE LANDSCAPING PLANS FOR LANDSCAPING REQUIREMENTS.
4. SEE STAGE 2 CROSS SECTIONS FOR GRADING INFORMATION.

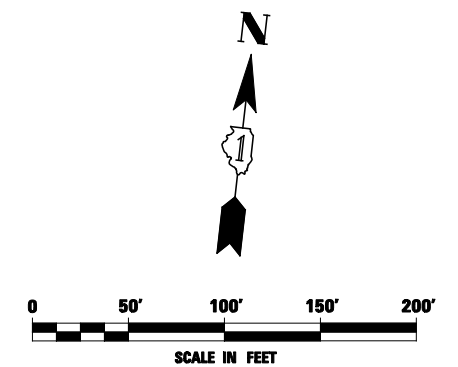

FILE NAME = #FILEL#	USER NAME = #USER#	DESIGNED <i>PJO</i>	REVISED -	<b>STATE OF ILLINOIS DEPARTMENT OF TRANSPORTATION</b>	<b>EROSION CONTROL - STAGE 2 RAMP A</b>	F.A.P. RTE.	SECTION	COUNTY	TOTAL SHEETS	SHEET NO.	
		DRAWN <i>KES</i>	REVISED -			338	(112 & 113) WRS-5	DUPAGE	963	508	
		CHECKED <i>JCM</i>	REVISED -			CONTRACT NO. 60I31					
		DATE <i>10/15/2012</i>	REVISED -			ILLINOIS FED. AID PROJECT					
				SCALE:	SHEET NO. 33 OF 66 SHEETS	STA. 1019+00	TO STA. 1033+00				



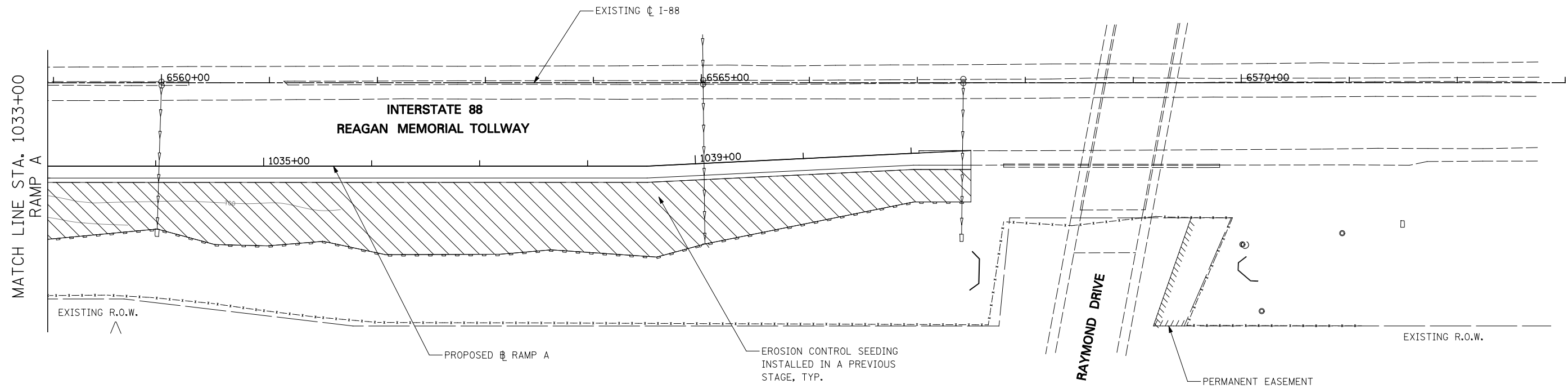

**EROSION CONTROL LEGEND**

	TEMPORARY EROSION CONTROL SEEDING AND TEMPORARY EROSION CONTROL BLANKET		TEMPORARY DITCH CHECK
	PERMANENT SEEDING (SEE NOTE 3)		TEMPORARY DITCH CHECK INSTALLED IN PREVIOUS STAGE
	TEMPORARY EROSION CONTROL SEEDING OR PERMANENT SEEDING INSTALLED IN A PREVIOUS STAGE		INLET & PIPE PROTECTION
	TEMPORARY PAVEMENT		INLET & PIPE PROTECTION INSTALLED IN PREVIOUS STAGE
	PERIMETER EROSION BARRIER (SEE NOTE 2)		FLOW DIRECTION (SEE NOTE 4)
	PERIMETER EROSION BARRIER INSTALLED IN PREVIOUS STAGE		PROPOSED STORM SEWER (SEE NOTE 1)
	INLET FILTER		PROPOSED STORM SEWER INSTALLED IN PREVIOUS STAGE
	INLET FILTER INSTALLED IN PREVIOUS STAGE		TEMPORARY PIPE CULVERT
	PERMANENT DRAINAGE STRUCTURE NUMBER (SEE NOTE 1)		

**NOTES**



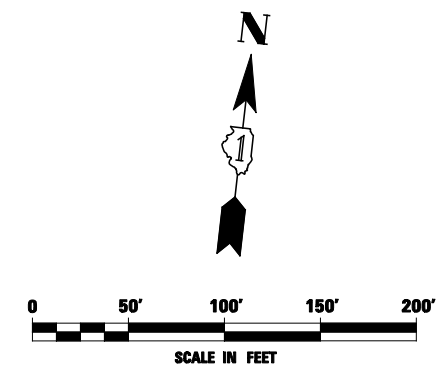



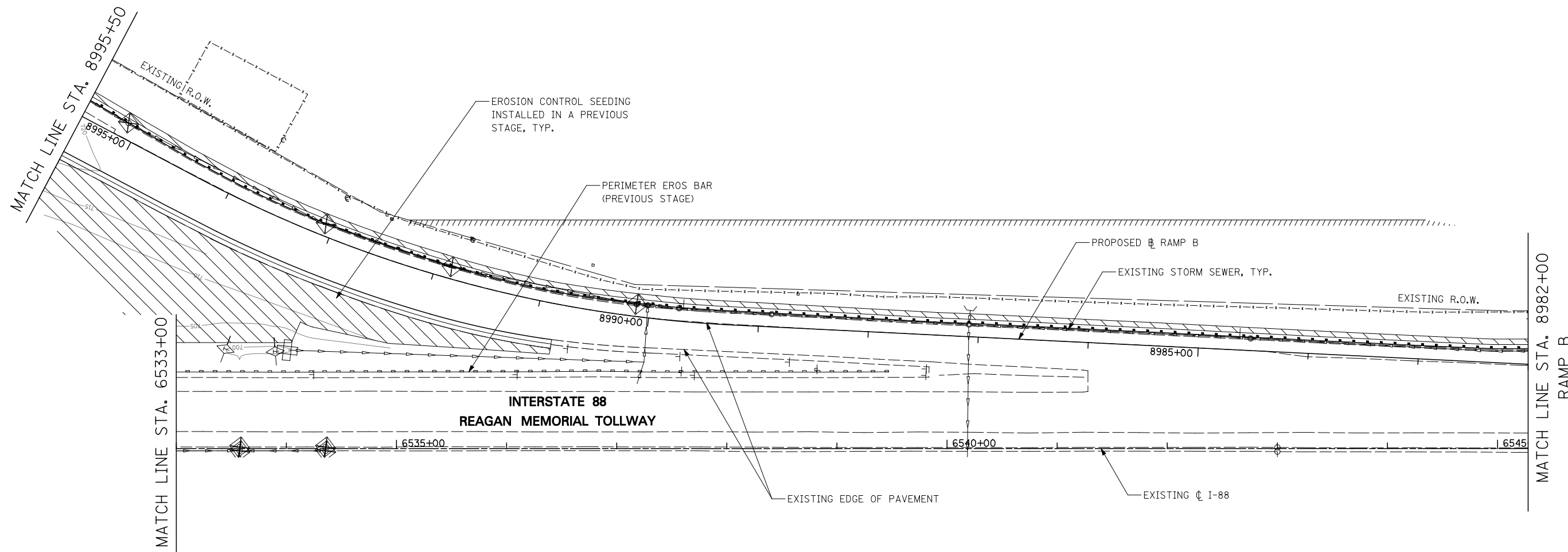



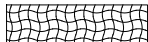





1. SEE PROPOSED DRAINAGE PLANS FOR STORM SEWER INFORMATION
2. PERIMETER EROSION BARRIER SHALL BE ERECTED ADJACENT TO R.O.W., EASEMENT, AND CONSTRUCTION LIMITS AND AS DIRECTED BY THE ENGINEER.
3. SEE LANDSCAPING PLANS FOR LANDSCAPING REQUIREMENTS.
4. SEE STAGE 2 CROSS SECTIONS FOR GRADING INFORMATION.

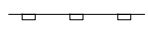

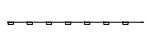
FILE NAME = #FILEL#	USER NAME = #USER#	DESIGNED <i>PJO</i>	REVISED -	<b>STATE OF ILLINOIS DEPARTMENT OF TRANSPORTATION</b>	<b>EROSION CONTROL - STAGE 2 RAMP A</b>		F.A.P. RTE.	SECTION	COUNTY	TOTAL SHEETS	SHEET NO.	
		DRAWN <i>KES</i>	REVISED -		SCALE:	SHEET NO. 34 OF 66 SHEETS	STA. 1033+00 TO STA. 1041+55	338	(112 & 113) WRS-5	DUPAGE	963	509
		CHECKED <i>JCM</i>	REVISED -		CONTRACT NO. 60I31							
		DATE <i>10/15/2012</i>	REVISED -		ILLINOIS FED. AID PROJECT							



**EROSION CONTROL LEGEND**

	TEMPORARY EROSION CONTROL SEEDING AND TEMPORARY EROSION CONTROL BLANKET		TEMPORARY DITCH CHECK
	PERMANENT SEEDING (SEE NOTE 3)		TEMPORARY DITCH CHECK INSTALLED IN PREVIOUS STAGE
	TEMPORARY EROSION CONTROL SEEDING OR PERMANENT SEEDING INSTALLED IN A PREVIOUS STAGE		INLET & PIPE PROTECTION
	TEMPORARY PAVEMENT		INLET & PIPE PROTECTION INSTALLED IN PREVIOUS STAGE
	PERIMETER EROSION BARRIER (SEE NOTE 2)		FLOW DIRECTION (SEE NOTE 4)
	PERIMETER EROSION BARRIER INSTALLED IN PREVIOUS STAGE		PROPOSED STORM SEWER (SEE NOTE 1)
	INLET FILTER		PROPOSED STORM SEWER INSTALLED IN PREVIOUS STAGE
	INLET FILTER INSTALLED IN PREVIOUS STAGE		TEMPORARY PIPE CULVERT
	PERMANENT DRAINAGE STRUCTURE NUMBER (SEE NOTE 1)		

**NOTES**

1. SEE PROPOSED DRAINAGE PLANS FOR STORM SEWER INFORMATION
2. PERIMETER EROSION BARRIER SHALL BE ERECTED ADJACENT TO R.O.W., EASEMENT, AND CONSTRUCTION LIMITS AND AS DIRECTED BY THE ENGINEER.
3. SEE LANDSCAPING PLANS FOR LANDSCAPING REQUIREMENTS.
4. SEE STAGE 2 CROSS SECTIONS FOR GRADING INFORMATION.

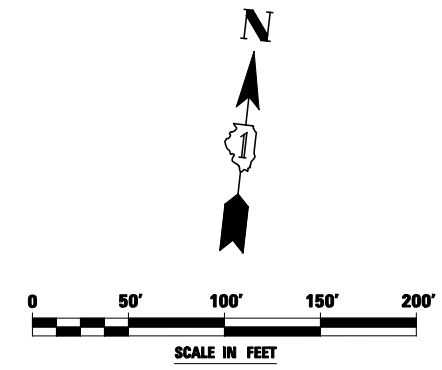

FILE NAME = #FILE#	USER NAME = #USER#	DESIGNED <i>PJO</i>	REVISED -	<b>STATE OF ILLINOIS DEPARTMENT OF TRANSPORTATION</b>	<b>EROSION CONTROL - STAGE 2 RAMP B</b>		F.A.P. RTE.	SECTION	COUNTY	TOTAL SHEETS	SHEET NO.	
		DRAWN <i>KES</i>	REVISED -		SCALE:	SHEET NO. 35 OF 66 SHEETS	STA. 8982+00 TO STA. 8995+50	338	(112 & 113) WRS-5	DUPAGE	963	510
		CHECKED <i>JCM</i>	REVISED -		CONTRACT NO. 60I31							
		DATE <i>10/15/2012</i>	REVISED -		ILLINOIS FED. AID PROJECT							

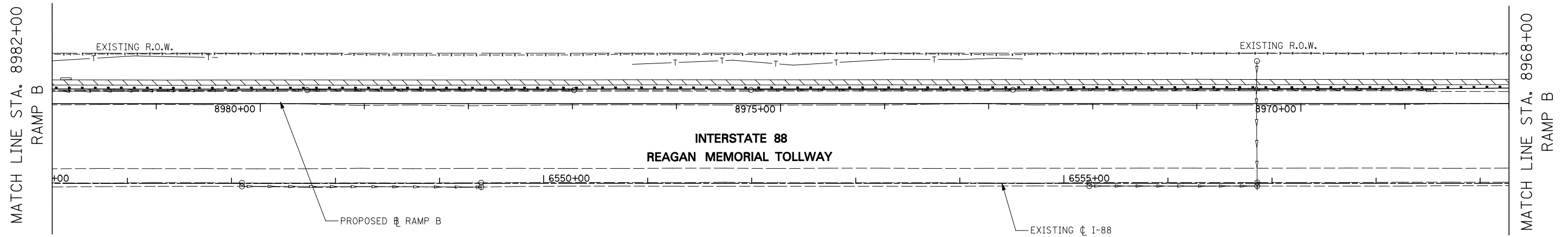

**EROSION CONTROL LEGEND**

	TEMPORARY EROSION CONTROL SEEDING AND TEMPORARY EROSION CONTROL BLANKET		TEMPORARY DITCH CHECK
	PERMANENT SEEDING (SEE NOTE 3)		TEMPORARY DITCH CHECK INSTALLED IN PREVIOUS STAGE
	TEMPORARY EROSION CONTROL SEEDING OR PERMANENT SEEDING INSTALLED IN A PREVIOUS STAGE		INLET & PIPE PROTECTION
	TEMPORARY PAVEMENT		INLET & PIPE PROTECTION INSTALLED IN PREVIOUS STAGE
	PERIMETER EROSION BARRIER (SEE NOTE 2)		FLOW DIRECTION (SEE NOTE 4)
	PERIMETER EROSION BARRIER INSTALLED IN PREVIOUS STAGE		PROPOSED STORM SEWER (SEE NOTE 1)
	INLET FILTER		PROPOSED STORM SEWER INSTALLED IN PREVIOUS STAGE
	INLET FILTER INSTALLED IN PREVIOUS STAGE		TEMPORARY PIPE CULVERT
	PERMANENT DRAINAGE STRUCTURE NUMBER (SEE NOTE 1)		(* ) - SEE NOTE 5

**NOTES**

1. SEE PROPOSED DRAINAGE PLANS FOR STORM SEWER INFORMATION
2. PERIMETER EROSION BARRIER SHALL BE ERECTED ADJACENT TO R.O.W., EASEMENT, AND CONSTRUCTION LIMITS AND AS DIRECTED BY THE ENGINEER.
3. SEE LANDSCAPING PLANS FOR LANDSCAPING REQUIREMENTS.
4. SEE STAGE 2 CROSS SECTIONS FOR GRADING INFORMATION.

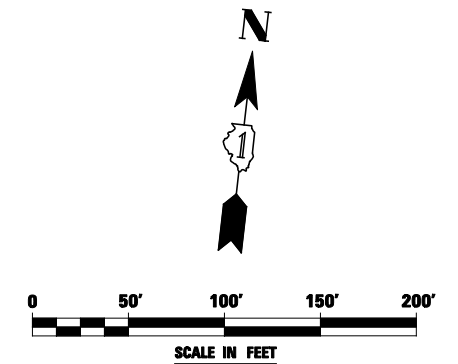

FILE NAME = #FILEL#	USER NAME = #USER#	DESIGNED <i>PJO</i>	REVISED -	<b>STATE OF ILLINOIS DEPARTMENT OF TRANSPORTATION</b>	<b>EROSION CONTROL - STAGE 2 RAMP B</b>		F.A.P. RTE.	SECTION	COUNTY	TOTAL SHEETS	SHEET NO.	
		DRAWN <i>KES</i>	REVISED -		SCALE:	SHEET NO. 36 OF 66 SHEETS	STA. 8968+00 TO STA. 8982+00	338	(112 & 113) WRS-5	DUPAGE	963	511
		CHECKED <i>JCM</i>	REVISED -		CONTRACT NO. 60I31							
		DATE <i>10/15/2012</i>	REVISED -		ILLINOIS FED. AID PROJECT							

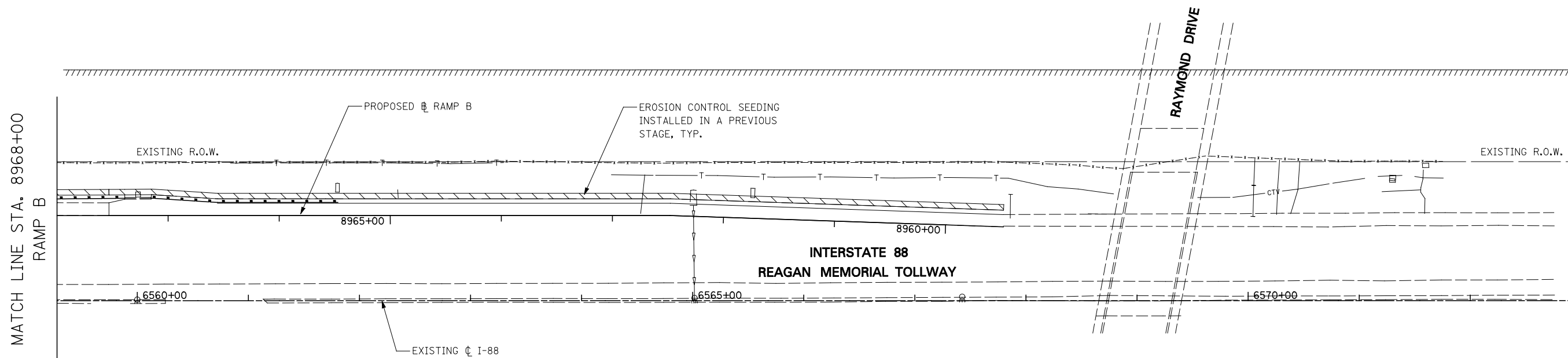

**EROSION CONTROL LEGEND**

	TEMPORARY EROSION CONTROL SEEDING AND TEMPORARY EROSION CONTROL BLANKET		TEMPORARY DITCH CHECK
	PERMANENT SEEDING (SEE NOTE 3)		TEMPORARY DITCH CHECK INSTALLED IN PREVIOUS STAGE
	TEMPORARY EROSION CONTROL SEEDING OR PERMANENT SEEDING INSTALLED IN A PREVIOUS STAGE		INLET & PIPE PROTECTION
	TEMPORARY PAVEMENT		INLET & PIPE PROTECTION INSTALLED IN PREVIOUS STAGE
	PERIMETER EROSION BARRIER (SEE NOTE 2)		FLOW DIRECTION (SEE NOTE 4)
	PERIMETER EROSION BARRIER INSTALLED IN PREVIOUS STAGE		PROPOSED STORM SEWER (SEE NOTE 1)
	INLET FILTER		PROPOSED STORM SEWER INSTALLED IN PREVIOUS STAGE
	INLET FILTER INSTALLED IN PREVIOUS STAGE		TEMPORARY PIPE CULVERT
	PERMANENT DRAINAGE STRUCTURE NUMBER (SEE NOTE 1)		

**NOTES**

- SEE PROPOSED DRAINAGE PLANS FOR STORM SEWER INFORMATION
- PERIMETER EROSION BARRIER SHALL BE ERECTED ADJACENT TO R.O.W., EASEMENT, AND CONSTRUCTION LIMITS AND AS DIRECTED BY THE ENGINEER.
- SEE LANDSCAPING PLANS FOR LANDSCAPING REQUIREMENTS.
- SEE STAGE 2 CROSS SECTIONS FOR GRADING INFORMATION.

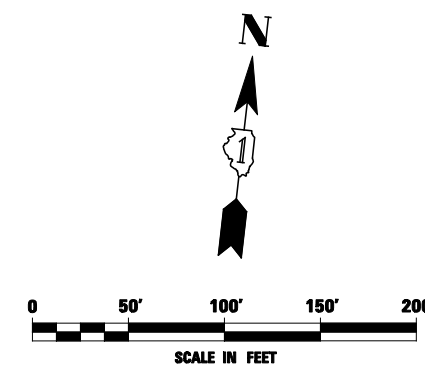

FILE NAME = #FILE#	USER NAME = #USER#	DESIGNED <i>PJO</i>	REVISED -	<b>STATE OF ILLINOIS DEPARTMENT OF TRANSPORTATION</b>	<b>EROSION CONTROL - STAGE 2 RAMP B</b>	F.A.P. RTE.	SECTION	COUNTY	TOTAL SHEETS	SHEET NO.	
		DRAWN <i>KES</i>	REVISED -			338	(112 & 113) WRS-5	DUPAGE	963	512	
		CHECKED <i>JCM</i>	REVISED -			CONTRACT NO. 60I31					
		DATE <i>10/15/2012</i>	REVISED -			ILLINOIS FED. AID PROJECT					
				SCALE:	SHEET NO. 37 OF 66 SHEETS	STA. 8959+48	TO STA. 8968+00				

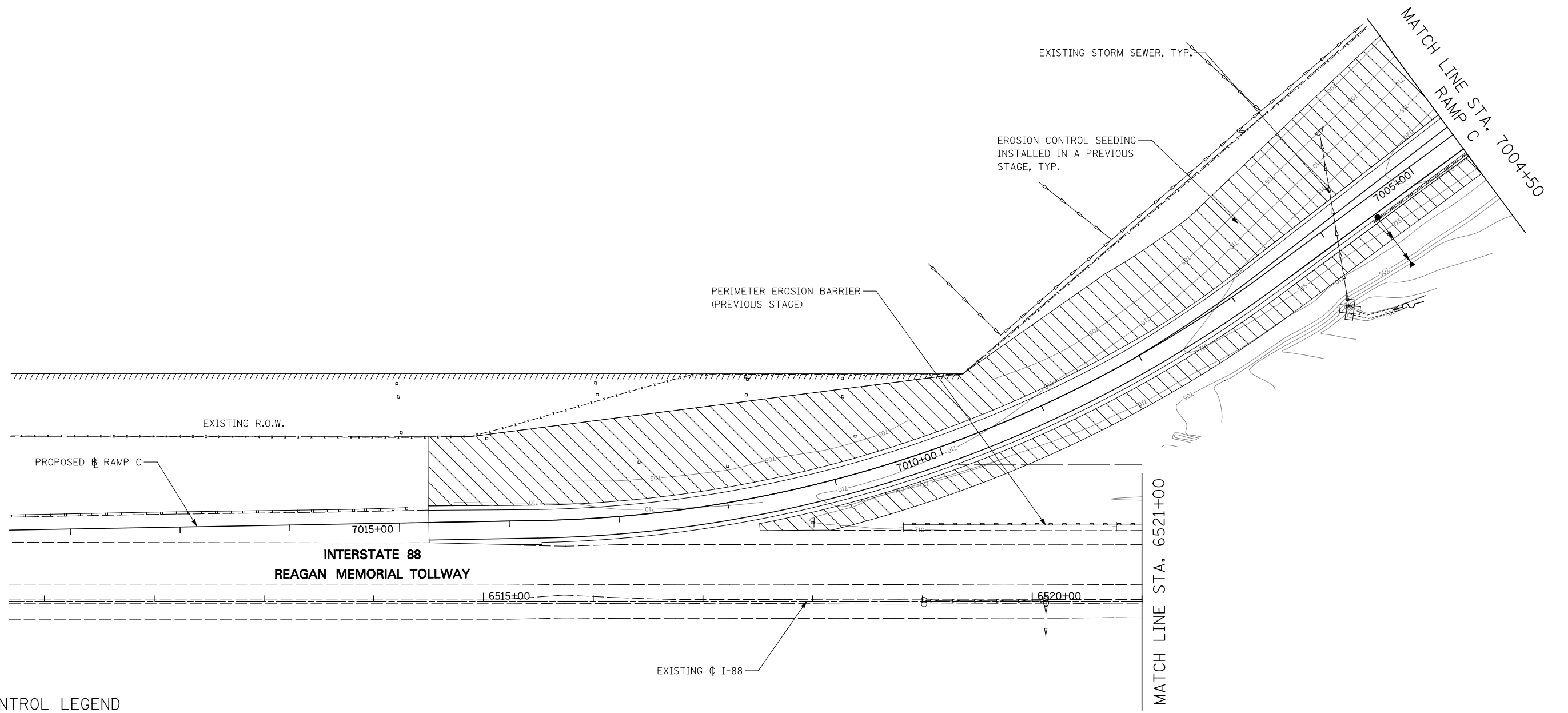

**EROSION CONTROL LEGEND**

	TEMPORARY EROSION CONTROL SEEDING AND TEMPORARY EROSION CONTROL BLANKET		TEMPORARY DITCH CHECK
	PERMANENT SEEDING (SEE NOTE 3)		TEMPORARY DITCH CHECK INSTALLED IN PREVIOUS STAGE
	TEMPORARY EROSION CONTROL SEEDING OR PERMANENT SEEDING INSTALLED IN A PREVIOUS STAGE		INLET & PIPE PROTECTION
	TEMPORARY PAVEMENT		INLET & PIPE PROTECTION INSTALLED IN PREVIOUS STAGE
	PERIMETER EROSION BARRIER (SEE NOTE 2)		FLOW DIRECTION (SEE NOTE 4)
	PERIMETER EROSION BARRIER INSTALLED IN PREVIOUS STAGE		PROPOSED STORM SEWER (SEE NOTE 1)
	INLET FILTER		PROPOSED STORM SEWER INSTALLED IN PREVIOUS STAGE
	INLET FILTER INSTALLED IN PREVIOUS STAGE		TEMPORARY PIPE CULVERT
	PERMANENT DRAINAGE STRUCTURE NUMBER (SEE NOTE 1)		

**NOTES**

1. SEE PROPOSED DRAINAGE PLANS FOR STORM SEWER INFORMATION
2. PERIMETER EROSION BARRIER SHALL BE ERECTED ADJACENT TO R.O.W., EASEMENT, AND CONSTRUCTION LIMITS AND AS DIRECTED BY THE ENGINEER.
3. SEE LANDSCAPING PLANS FOR LANDSCAPING REQUIREMENTS.
4. SEE STAGE 2 CROSS SECTIONS FOR GRADING INFORMATION.

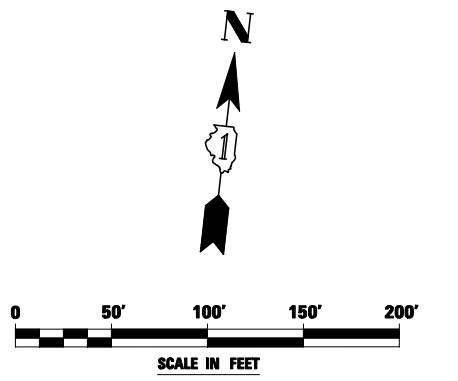

FILE NAME =	USER NAME = #USER#	DESIGNED <i>PJO</i>	REVISED -
#FILEL#		DRAWN <i>KES</i>	REVISED -
	PLOT SCALE = #SCALE#	CHECKED <i>JCM</i>	REVISED -
	PLOT DATE = #DATE#	DATE <i>10/15/2012</i>	REVISED -

**STATE OF ILLINOIS  
DEPARTMENT OF TRANSPORTATION**

**EROSION CONTROL - STAGE 2  
RAMP C**

SCALE: SHEET NO. 38 OF 66 SHEETS STA. 7004+50 TO STA. 7018+55

F.A.P. RTE.	SECTION	COUNTY	TOTAL SHEETS	SHEET NO.
338	(112 & 113) WRS-5	DUPAGE	963	513
CONTRACT NO. 60I31				
ILLINOIS FED. AID PROJECT				

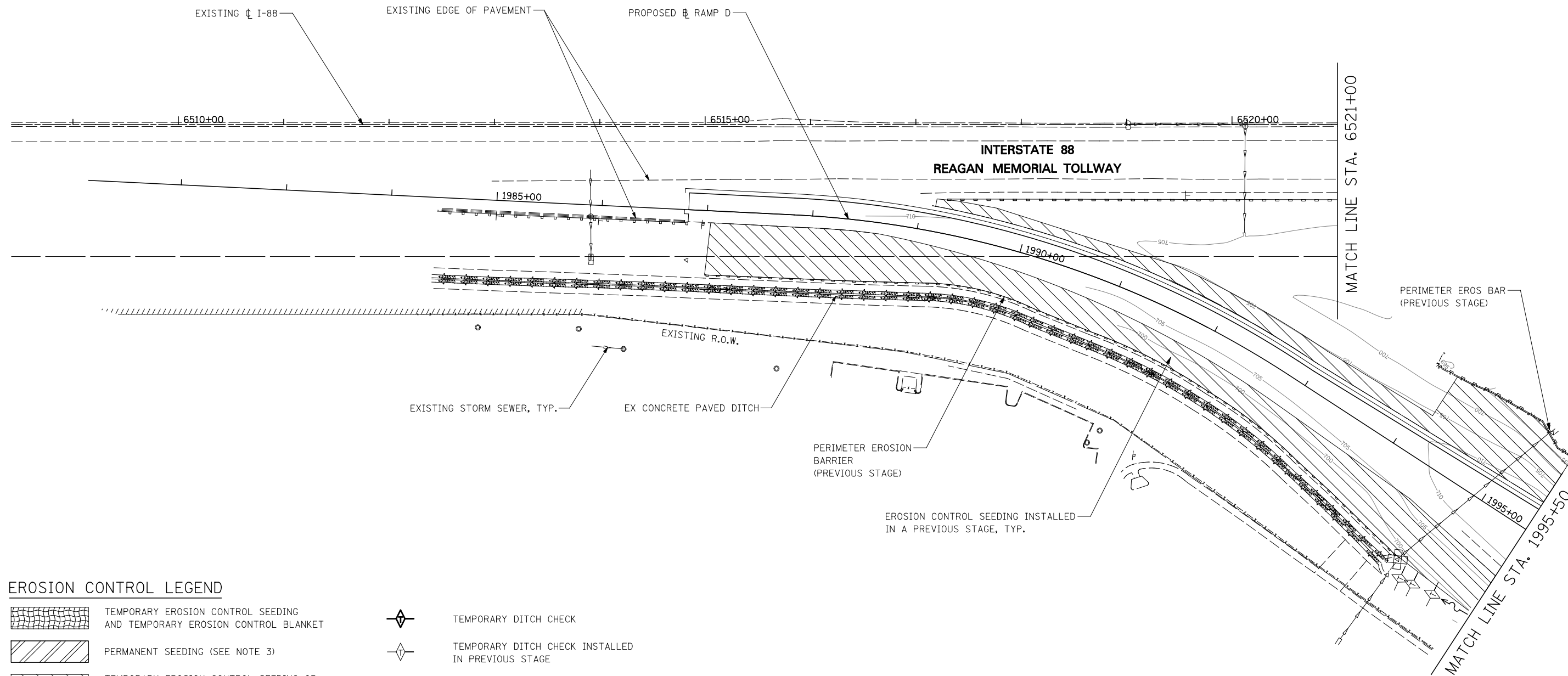

**EROSION CONTROL LEGEND**

	TEMPORARY EROSION CONTROL SEEDING AND TEMPORARY EROSION CONTROL BLANKET		TEMPORARY DITCH CHECK
	PERMANENT SEEDING (SEE NOTE 3)		TEMPORARY DITCH CHECK INSTALLED IN PREVIOUS STAGE
	TEMPORARY EROSION CONTROL SEEDING OR PERMANENT SEEDING INSTALLED IN A PREVIOUS STAGE		INLET & PIPE PROTECTION
	TEMPORARY PAVEMENT		INLET & PIPE PROTECTION INSTALLED IN PREVIOUS STAGE
	PERIMETER EROSION BARRIER (SEE NOTE 2)		FLOW DIRECTION (SEE NOTE 4)
	PERIMETER EROSION BARRIER INSTALLED IN PREVIOUS STAGE		PROPOSED STORM SEWER (SEE NOTE 1)
	INLET FILTER		PROPOSED STORM SEWER INSTALLED IN PREVIOUS STAGE
	INLET FILTER INSTALLED IN PREVIOUS STAGE		TEMPORARY PIPE CULVERT
	PERMANENT DRAINAGE STRUCTURE NUMBER (SEE NOTE 1)		

**NOTES**

1. SEE PROPOSED DRAINAGE PLANS FOR STORM SEWER INFORMATION
2. PERIMETER EROSION BARRIER SHALL BE ERECTED ADJACENT TO R.O.W., EASEMENT, AND CONSTRUCTION LIMITS AND AS DIRECTED BY THE ENGINEER.
3. SEE LANDSCAPING PLANS FOR LANDSCAPING REQUIREMENTS.
4. SEE STAGE 2 CROSS SECTIONS FOR GRADING INFORMATION.

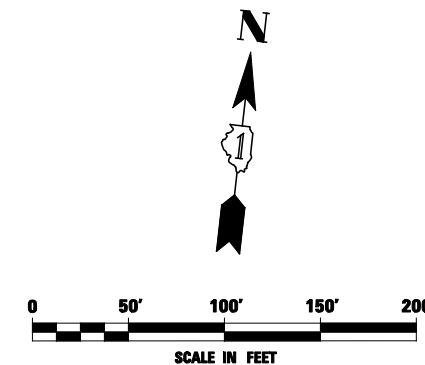

FILE NAME =	USER NAME = #USER#	DESIGNED <i>PJO</i>	REVISED -
#FILEL#		DRAWN <i>KES</i>	REVISED -
	PLOT SCALE = #SCALE#	CHECKED <i>JCM</i>	REVISED -
	PLOT DATE = #DATE#	DATE <i>10/15/2012</i>	REVISED -

**STATE OF ILLINOIS  
DEPARTMENT OF TRANSPORTATION**

**EROSION CONTROL - STAGE 2  
RAMP D**

SCALE: SHEET NO. 39 OF 66 SHEETS STA. 1981+22 TO STA. 1995+50

F.A.P. RTE.	SECTION	COUNTY	TOTAL SHEETS	SHEET NO.
338	(112 & 113) WRS-5	DUPAGE	963	514
CONTRACT NO. 60I31				
ILLINOIS FED. AID PROJECT				

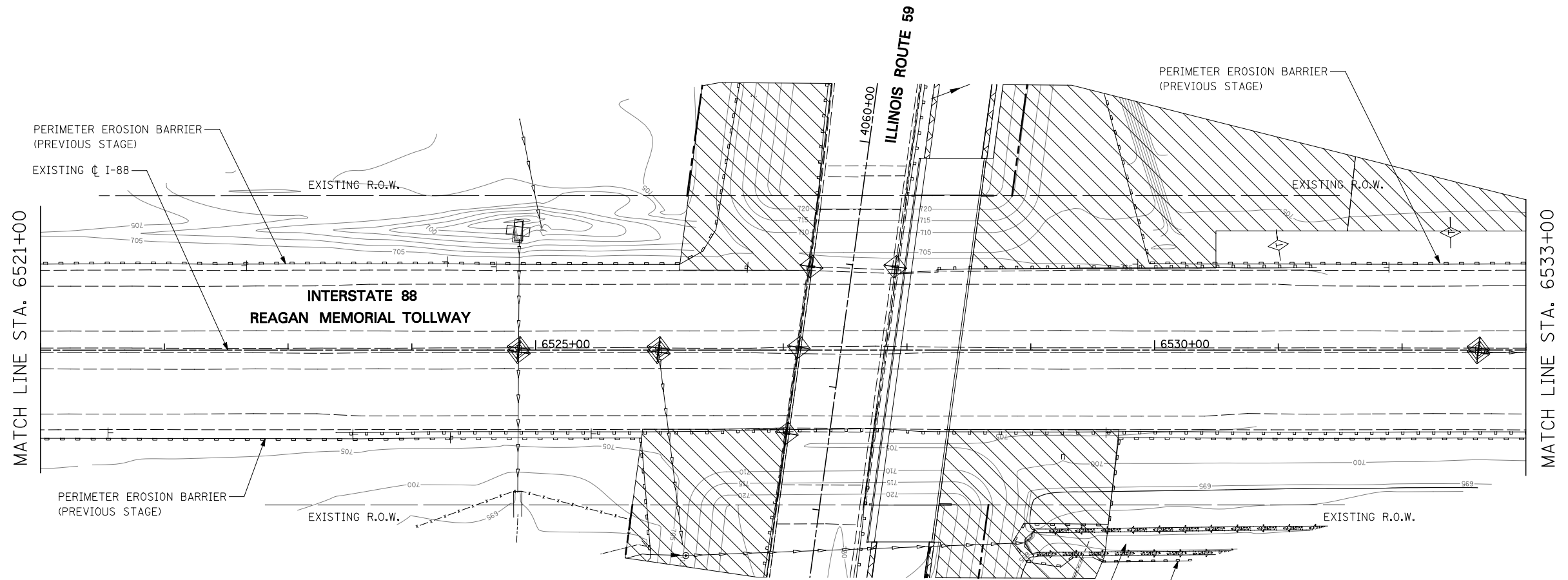

**EROSION CONTROL LEGEND**

- |  |                                                                                      |  |                                                     |
|--|--------------------------------------------------------------------------------------|--|-----------------------------------------------------|
|  | TEMPORARY EROSION CONTROL SEEDING AND TEMPORARY EROSION CONTROL BLANKET              |  | TEMPORARY DITCH CHECK                               |
|  | PERMANENT SEEDING (SEE NOTE 3)                                                       |  | TEMPORARY DITCH CHECK INSTALLED IN PREVIOUS STAGE   |
|  | TEMPORARY EROSION CONTROL SEEDING OR PERMANENT SEEDING INSTALLED IN A PREVIOUS STAGE |  | INLET & PIPE PROTECTION                             |
|  | TEMPORARY PAVEMENT                                                                   |  | INLET & PIPE PROTECTION INSTALLED IN PREVIOUS STAGE |
|  | PERIMETER EROSION BARRIER (SEE NOTE 2)                                               |  | FLOW DIRECTION (SEE NOTE 4)                         |
|  | PERIMETER EROSION BARRIER INSTALLED IN PREVIOUS STAGE                                |  | PROPOSED STORM SEWER (SEE NOTE 1)                   |
|  | INLET FILTER                                                                         |  | PROPOSED STORM SEWER INSTALLED IN PREVIOUS STAGE    |
|  | INLET FILTER INSTALLED IN PREVIOUS STAGE                                             |  | TEMPORARY PIPE CULVERT                              |
|  | PERMANENT DRAINAGE STRUCTURE NUMBER (SEE NOTE 1)                                     |  |                                                     |

**NOTES**

- SEE PROPOSED DRAINAGE PLANS FOR STORM SEWER INFORMATION
- PERIMETER EROSION BARRIER SHALL BE ERECTED ADJACENT TO R.O.W., EASEMENT, AND CONSTRUCTION LIMITS AND AS DIRECTED BY THE ENGINEER.
- SEE LANDSCAPING PLANS FOR LANDSCAPING REQUIREMENTS.
- SEE STAGE 2 CROSS SECTIONS FOR GRADING INFORMATION.

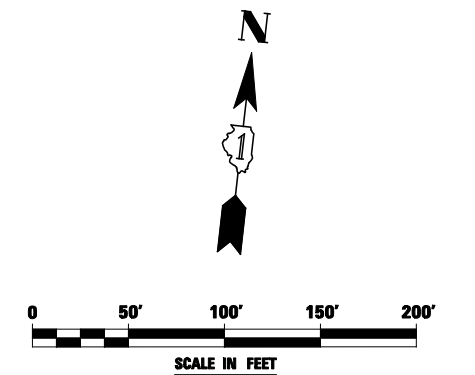

FILE NAME = #FILE#	USER NAME = #USER#	DESIGNED <i>PJO</i>	REVISED -	<b>STATE OF ILLINOIS DEPARTMENT OF TRANSPORTATION</b>	<b>EROSION CONTROL - STAGE 2 INTERSTATE I-88</b>	F.A.P. RTE.	SECTION	COUNTY	TOTAL SHEETS	SHEET NO.	
		DRAWN <i>KES</i>	REVISED -			338	(112 & 113) WRS-5	DUPAGE	963	515	
		CHECKED <i>JCM</i>	REVISED -			CONTRACT NO. 60I31					
		DATE <i>10/15/2012</i>	REVISED -			ILLINOIS FED. AID PROJECT					
				SCALE:	SHEET NO. 40 OF 66 SHEETS	STA. 6521+00 TO STA. 6533+00					

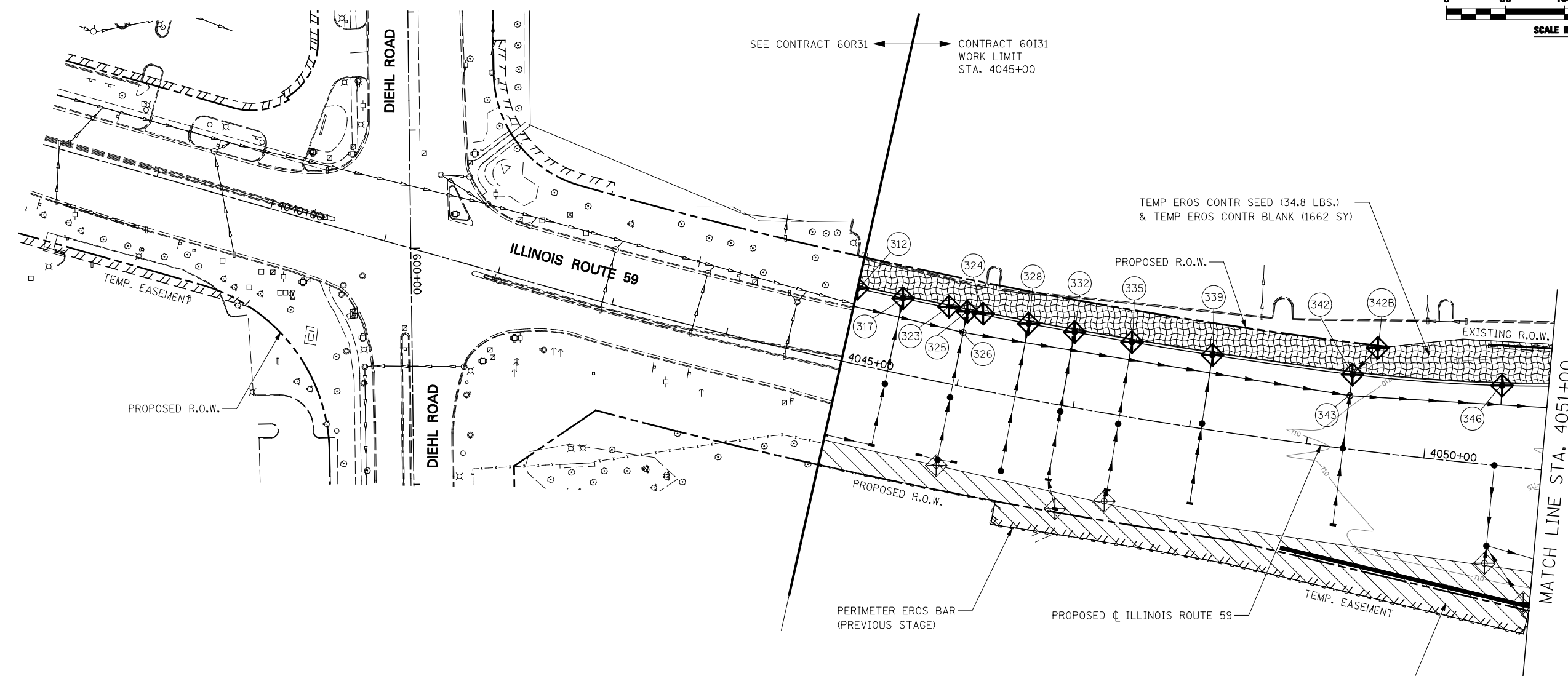
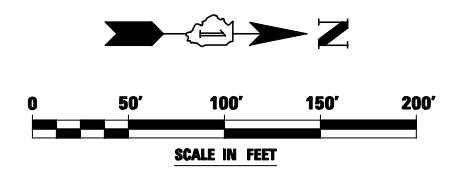

**EROSION CONTROL LEGEND**

- |  |                                                                                      |  |                                                     |
|--|--------------------------------------------------------------------------------------|--|-----------------------------------------------------|
|  | TEMPORARY EROSION CONTROL SEEDING AND TEMPORARY EROSION CONTROL BLANKET              |  | TEMPORARY DITCH CHECK                               |
|  | PERMANENT SEEDING (SEE NOTE 3)                                                       |  | TEMPORARY DITCH CHECK INSTALLED IN PREVIOUS STAGE   |
|  | TEMPORARY EROSION CONTROL SEEDING OR PERMANENT SEEDING INSTALLED IN A PREVIOUS STAGE |  | INLET & PIPE PROTECTION                             |
|  | TEMPORARY PAVEMENT                                                                   |  | INLET & PIPE PROTECTION INSTALLED IN PREVIOUS STAGE |
|  | PERIMETER EROSION BARRIER (SEE NOTE 2)                                               |  | FLOW DIRECTION (SEE NOTE 4)                         |
|  | PERIMETER EROSION BARRIER INSTALLED IN PREVIOUS STAGE                                |  | PROPOSED STORM SEWER (SEE NOTE 1)                   |
|  | INLET FILTER                                                                         |  | PROPOSED STORM SEWER INSTALLED IN PREVIOUS STAGE    |
|  | INLET FILTER INSTALLED IN PREVIOUS STAGE                                             |  | TEMPORARY PIPE CULVERT                              |
|  | PERMANENT DRAINAGE STRUCTURE NUMBER (SEE NOTE 1)                                     |  |                                                     |
- (\*) - SEE NOTE 5

**NOTES**

- SEE PROPOSED DRAINAGE PLANS FOR STORM SEWER INFORMATION
- PERIMETER EROSION BARRIER SHALL BE ERECTED ADJACENT TO R.O.W., EASEMENT, AND CONSTRUCTION LIMITS AND AS DIRECTED BY THE ENGINEER.
- SEE LANDSCAPING PLANS FOR LANDSCAPING REQUIREMENTS.
- SEE STAGE 3 CROSS SECTIONS FOR GRADING INFORMATION.
- PROPOSED STRUCTURE SHALL BE BURIED AND TEMPORARILY COVERED/CLOSED WITH STEEL PLATE OF THICKNESS SPECIFIED AND APPROVED BY THE ENGINEER. PAYMENT FOR THIS TEMPORARY COVER INSTALLATION AND REMOVAL SHALL BE CONSIDERED INCLUDED IN THE COST OF THE PROPOSED STRUCTURE.

FILE NAME = #FILEL#	USER NAME = #USER#	DESIGNED <i>PJO</i>	REVISED -	<b>STATE OF ILLINOIS DEPARTMENT OF TRANSPORTATION</b>	<b>EROSION CONTROL - STAGE 3, 3A, 3B, AND 3C ILLINOIS ROUTE 59</b>	F.A.P. RTE.	SECTION	COUNTY	TOTAL SHEETS	SHEET NO.	
		DRAWN <i>KES</i>	REVISED -			338	(112 & 113) WRS-5	DUPAGE	963	516	
		CHECKED <i>JCM</i>	REVISED -			CONTRACT NO. 60131					
		DATE <i>10/15/2012</i>	REVISED -			ILLINOIS FED. AID PROJECT					
				SCALE:	SHEET NO. 41 OF 66 SHEETS	STA. 4045+00 TO STA. 4051+00					



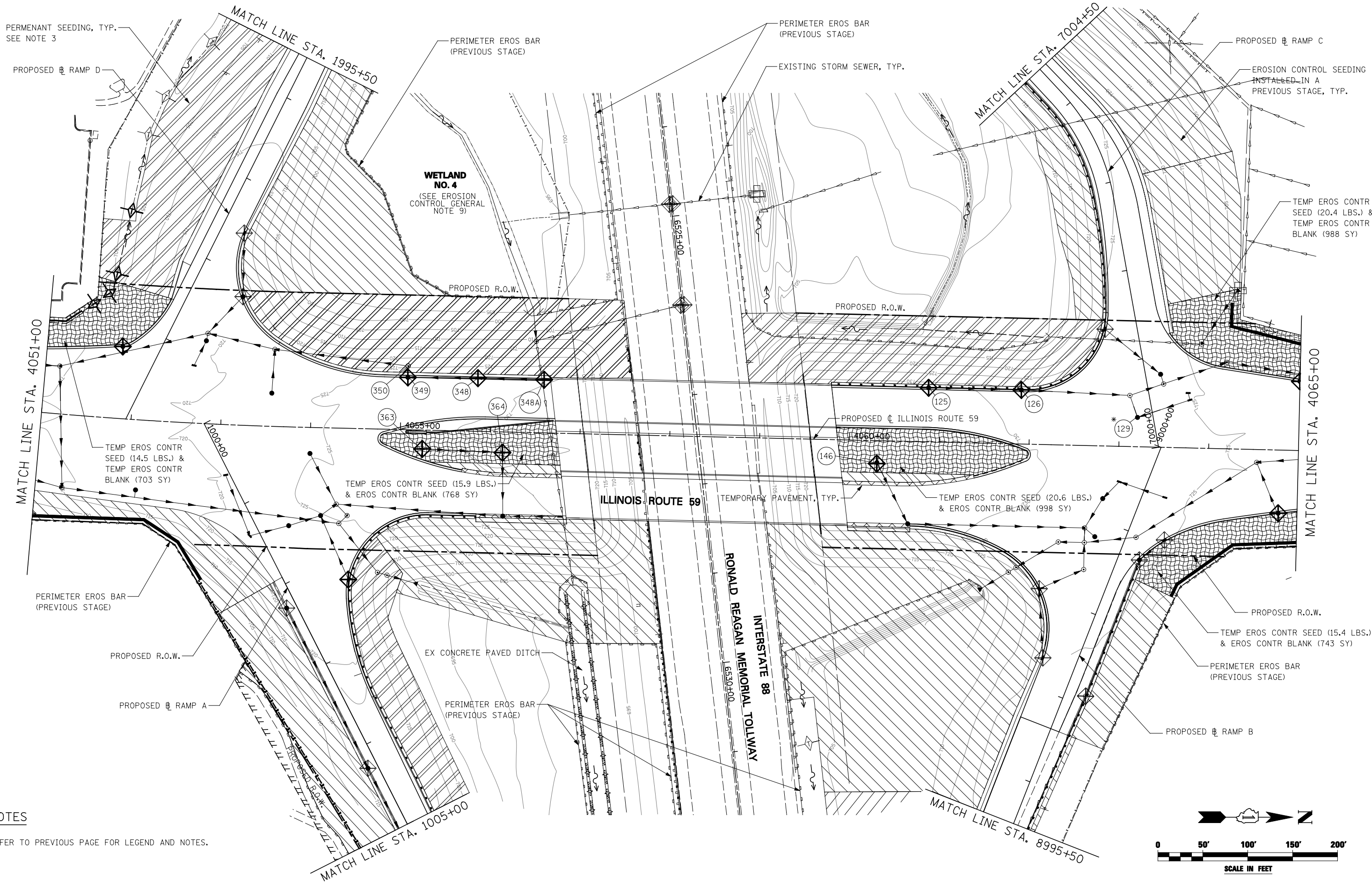

PERMANENT SEEDING, TYP.  
SEE NOTE 3

PROPOSED RAMP D

PERIMETER EROS BAR  
(PREVIOUS STAGE)

PERIMETER EROS BAR  
(PREVIOUS STAGE)

EXISTING STORM SEWER, TYP.

MATCH LINE STA. 7004+50

PROPOSED RAMP C

EROSION CONTROL SEEDING  
INSTALLED IN A  
PREVIOUS STAGE, TYP.

TEMP EROS CONTR  
SEED (20.4 LBS.) &  
TEMP EROS CONTR  
BLANK (988 SY)

**WETLAND  
NO. 4**  
(SEE EROSION  
CONTROL GENERAL  
NOTE 9)

PROPOSED R.O.W.

PROPOSED R.O.W.

MATCH LINE STA. 4051+00

TEMP EROS CONTR  
SEED (14.5 LBS.) &  
TEMP EROS CONTR  
BLANK (703 SY)

TEMP EROS CONTR SEED (15.9 LBS.)  
& EROS CONTR BLANK (768 SY)

ILLINOIS ROUTE 59

TEMPORARY PAVEMENT, TYP.

PROPOSED CL ILLINOIS ROUTE 59

TEMP EROS CONTR SEED (20.6 LBS.)  
& EROS CONTR BLANK (998 SY)

MATCH LINE STA. 4065+00

PERIMETER EROS BAR  
(PREVIOUS STAGE)

PROPOSED R.O.W.

PROPOSED RAMP A

EX CONCRETE PAVED DITCH

PERIMETER EROS BAR  
(PREVIOUS STAGE)

RONALD REAGAN MEMORIAL TOLLWAY  
INTERSTATE 88  
1 6530+00

PROPOSED R.O.W.  
TEMP EROS CONTR SEED (15.4 LBS.)  
& EROS CONTR BLANK (743 SY)

PERIMETER EROS BAR  
(PREVIOUS STAGE)

PROPOSED RAMP B





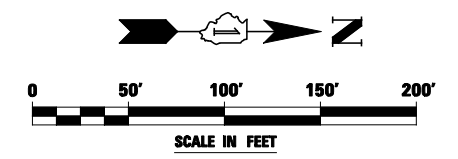





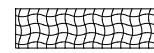



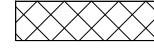

**NOTES**

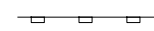
REFER TO PREVIOUS PAGE FOR LEGEND AND NOTES.



FILE NAME = #FILE#	USER NAME = #USER#	DESIGNED <i>PJO</i>	REVISED -	<b>STATE OF ILLINOIS DEPARTMENT OF TRANSPORTATION</b>	<b>EROSION CONTROL - STAGE 3, 3A, 3B, AND 3C ILLINOIS ROUTE 59</b>	F.A.P. RTE.	SECTION	COUNTY	TOTAL SHEETS	SHEET NO.	
		DRAWN <i>KES</i>	REVISED -			338	(112 & 113) WRS-5	DUPAGE	963	517	
		CHECKED <i>JCM</i>	REVISED -			CONTRACT NO. 60I31					
		DATE <i>10/15/2012</i>	REVISED -			ILLINOIS FED. AID PROJECT					
				SCALE:	SHEET NO. 42 OF 66 SHEETS	STA. 4051+00 TO STA. 4065+00					

**EROSION CONTROL LEGEND**

	TEMPORARY EROSION CONTROL SEEDING AND TEMPORARY EROSION CONTROL BLANKET		TEMPORARY DITCH CHECK
	PERMANENT SEEDING (SEE NOTE 3)		TEMPORARY DITCH CHECK INSTALLED IN PREVIOUS STAGE
	TEMPORARY EROSION CONTROL SEEDING OR PERMANENT SEEDING INSTALLED IN A PREVIOUS STAGE		INLET & PIPE PROTECTION
	TEMPORARY PAVEMENT		INLET & PIPE PROTECTION INSTALLED IN PREVIOUS STAGE
	PERIMETER EROSION BARRIER (SEE NOTE 2)		FLOW DIRECTION (SEE NOTE 4)
	PERIMETER EROSION BARRIER INSTALLED IN PREVIOUS STAGE		PROPOSED STORM SEWER (SEE NOTE 1)
	INLET FILTER		PROPOSED STORM SEWER INSTALLED IN PREVIOUS STAGE
	INLET FILTER INSTALLED IN PREVIOUS STAGE		TEMPORARY PIPE CULVERT
	PERMANENT DRAINAGE STRUCTURE NUMBER (SEE NOTE 1)		

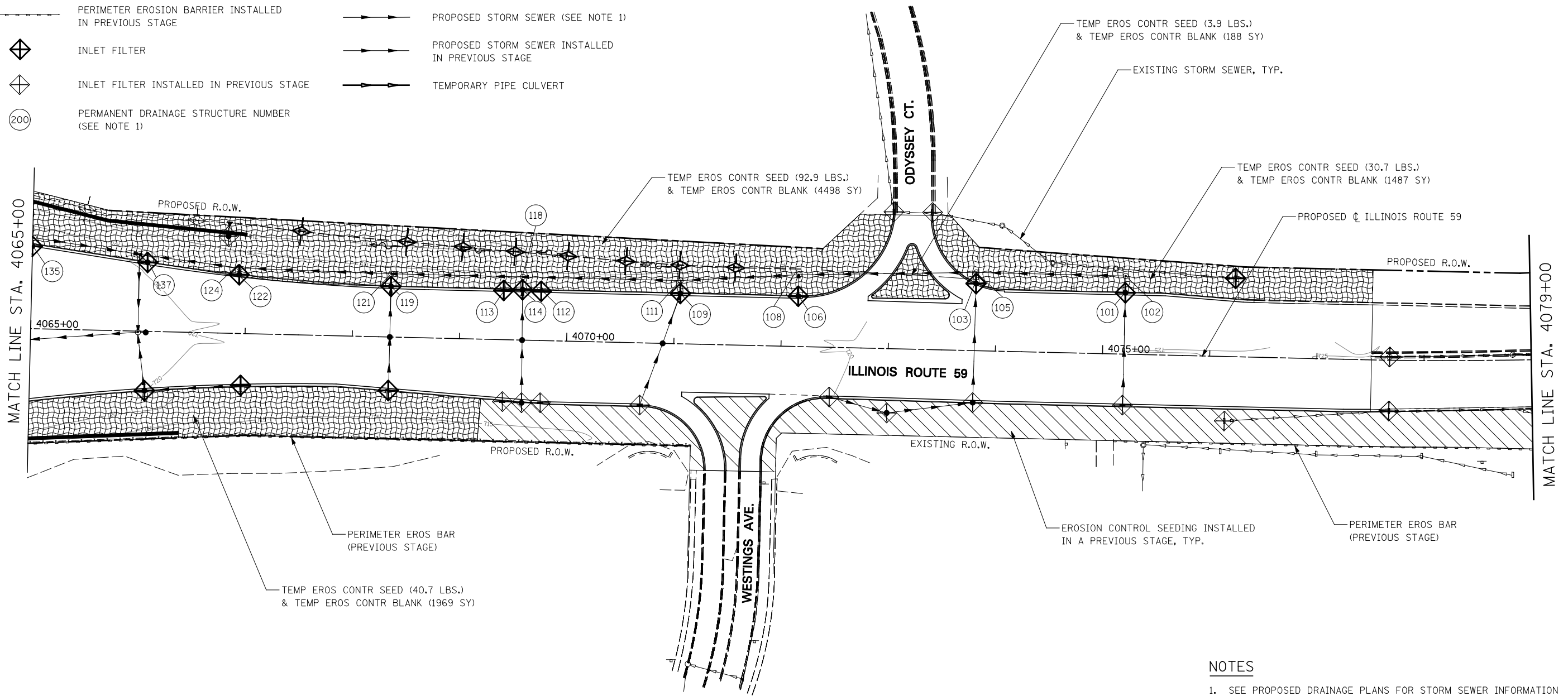
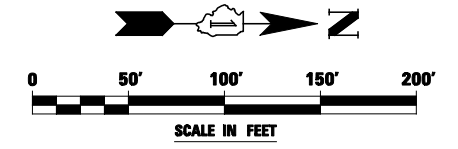











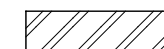

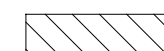



**NOTES**

1. SEE PROPOSED DRAINAGE PLANS FOR STORM SEWER INFORMATION
2. PERIMETER EROSION BARRIER SHALL BE ERECTED ADJACENT TO R.O.W., EASEMENT, AND CONSTRUCTION LIMITS AND AS DIRECTED BY THE ENGINEER.
3. SEE LANDSCAPING PLANS FOR LANDSCAPING REQUIREMENTS.
4. SEE STAGE 3 CROSS SECTIONS FOR GRADING INFORMATION.

FILE NAME = *FILEL*	USER NAME = *USER*	DESIGNED <i>PJO</i>	REVISED -	<b>STATE OF ILLINOIS DEPARTMENT OF TRANSPORTATION</b>	<b>EROSION CONTROL - STAGE 3, 3A, 3B, AND 3C ILLINOIS ROUTE 59</b>	F.A.P. RTE.	SECTION	COUNTY	TOTAL SHEETS	SHEET NO.	
	DRAWN <i>KES</i>	CHECKED <i>JCM</i>	REVISED -			338	(112 & 113) WRS-5	DUPAGE	963	518	
PLOT SCALE = *SCALE*	DATE <i>10/15/2012</i>		REVISED -			CONTRACT NO. 60I31					
PLOT DATE = *DATE*			REVISED -			ILLINOIS FED. AID PROJECT					
					SCALE:	SHEET NO. 43 OF 66 SHEETS		STA. 4065+00 TO STA. 4079+00			

### EROSION CONTROL LEGEND

	TEMPORARY EROSION CONTROL SEEDING AND TEMPORARY EROSION CONTROL BLANKET		TEMPORARY DITCH CHECK
	PERMANENT SEEDING (SEE NOTE 3)		TEMPORARY DITCH CHECK INSTALLED IN PREVIOUS STAGE
	TEMPORARY EROSION CONTROL SEEDING OR PERMANENT SEEDING INSTALLED IN A PREVIOUS STAGE		INLET & PIPE PROTECTION
	TEMPORARY PAVEMENT		INLET & PIPE PROTECTION INSTALLED IN PREVIOUS STAGE
	PERIMETER EROSION BARRIER (SEE NOTE 2)		FLOW DIRECTION (SEE NOTE 4)
	PERIMETER EROSION BARRIER INSTALLED IN PREVIOUS STAGE		PROPOSED STORM SEWER (SEE NOTE 1)
	INLET FILTER		PROPOSED STORM SEWER INSTALLED IN PREVIOUS STAGE
	INLET FILTER INSTALLED IN PREVIOUS STAGE		TEMPORARY PIPE CULVERT
	PERMANENT DRAINAGE STRUCTURE NUMBER (SEE NOTE 1)		

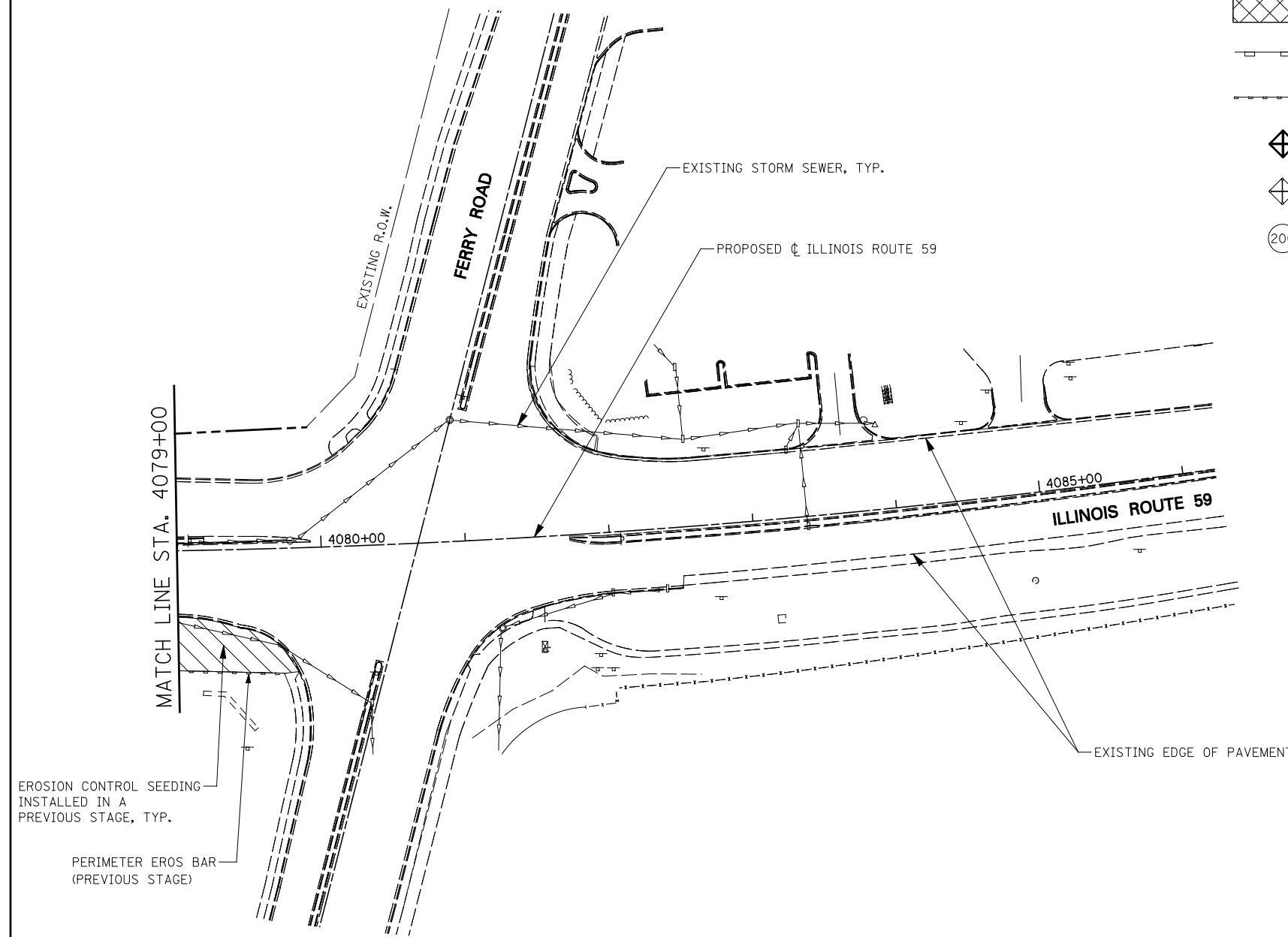

### NOTES

1. SEE PROPOSED DRAINAGE PLANS FOR STORM SEWER INFORMATION
2. PERIMETER EROSION BARRIER SHALL BE ERECTED ADJACENT TO R.O.W., EASEMENT, AND CONSTRUCTION LIMITS AND AS DIRECTED BY THE ENGINEER.
3. SEE LANDSCAPING PLANS FOR LANDSCAPING REQUIREMENTS.
4. SEE STAGE 3 CROSS SECTIONS FOR GRADING INFORMATION.

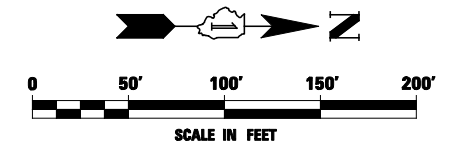

FILE NAME = #FILE#	USER NAME = #USER#	DESIGNED <i>PJO</i>	REVISED -	<b>STATE OF ILLINOIS DEPARTMENT OF TRANSPORTATION</b>	<b>EROSION CONTROL - STAGE 3, 3A, 3B, AND 3C ILLINOIS ROUTE 59</b>	F.A.P. RTE.	SECTION	COUNTY	TOTAL SHEETS	SHEET NO.	
		DRAWN <i>KES</i>	REVISED -			338	(112 & 113) WRS-5	DUPAGE	963	519	
		CHECKED <i>JCM</i>	REVISED -			CONTRACT NO. 60I31					
		DATE <i>10/15/2012</i>	REVISED -			SCALE:	SHEET NO. 44 OF 66 SHEETS	STA. 4079+00 TO STA. 4086+00	ILLINOIS FED. AID PROJECT		

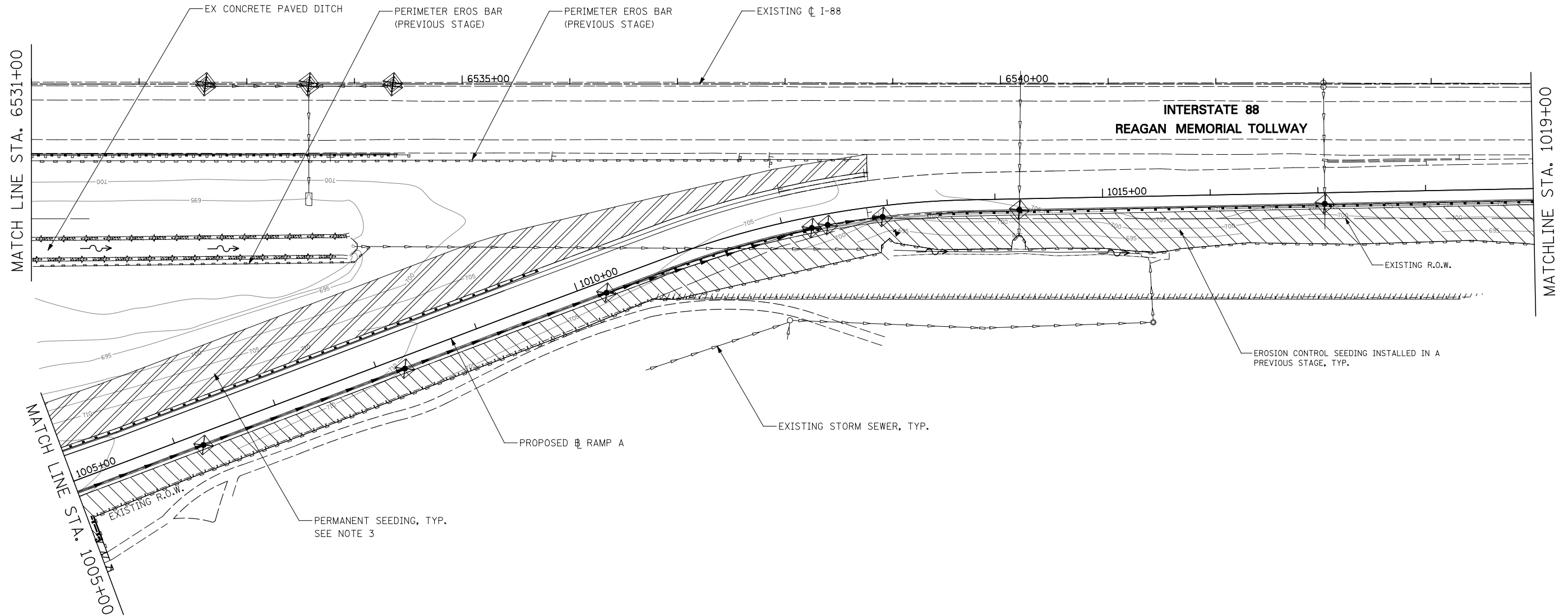

**EROSION CONTROL LEGEND**

	TEMPORARY EROSION CONTROL SEEDING AND TEMPORARY EROSION CONTROL BLANKET		TEMPORARY DITCH CHECK
	PERMANENT SEEDING (SEE NOTE 3)		TEMPORARY DITCH CHECK INSTALLED IN PREVIOUS STAGE
	TEMPORARY EROSION CONTROL SEEDING OR PERMANENT SEEDING INSTALLED IN A PREVIOUS STAGE		INLET & PIPE PROTECTION
	TEMPORARY PAVEMENT		INLET & PIPE PROTECTION INSTALLED IN PREVIOUS STAGE
	PERIMETER EROSION BARRIER (SEE NOTE 2)		FLOW DIRECTION (SEE NOTE 4)
	PERIMETER EROSION BARRIER INSTALLED IN PREVIOUS STAGE		PROPOSED STORM SEWER (SEE NOTE 1)
	INLET FILTER		PROPOSED STORM SEWER INSTALLED IN PREVIOUS STAGE
	INLET FILTER INSTALLED IN PREVIOUS STAGE		TEMPORARY PIPE CULVERT
	PERMANENT DRAINAGE STRUCTURE NUMBER (SEE NOTE 1)		

**NOTES**

- SEE PROPOSED DRAINAGE PLANS FOR STORM SEWER INFORMATION
- PERIMETER EROSION BARRIER SHALL BE ERECTED ADJACENT TO R.O.W., EASEMENT, AND CONSTRUCTION LIMITS AND AS DIRECTED BY THE ENGINEER.
- SEE LANDSCAPING PLANS FOR LANDSCAPING REQUIREMENTS.
- SEE STAGE 3 CROSS SECTIONS FOR GRADING INFORMATION.

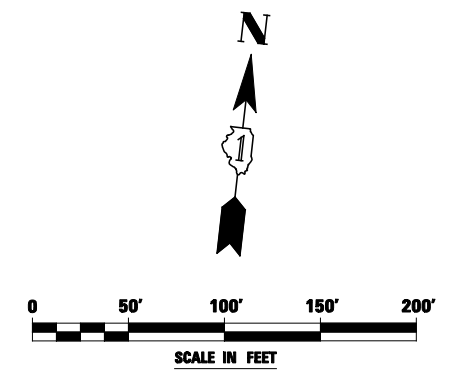

FILE NAME = #FILEL#	USER NAME = #USER#	DESIGNED <i>PJO</i>	REVISED -	<b>STATE OF ILLINOIS DEPARTMENT OF TRANSPORTATION</b>	<b>EROSION CONTROL - STAGE 3, 3A, 3B, AND 3C RAMP A</b>	F.A.P. RTE.	SECTION	COUNTY	TOTAL SHEETS	SHEET NO.	
	PLOT SCALE = #SCALE#	DRAWN <i>KES</i>	REVISED -			338	(112 & 113) WRS-5	DUPAGE	963	520	
	PLOT DATE = #DATE#	CHECKED <i>JCM</i>	REVISED -			CONTRACT NO. 60I31					
		DATE <i>10/15/2012</i>	REVISED -			ILLINOIS FED. AID PROJECT					
					SCALE:	SHEET NO. 45 OF 66 SHEETS		STA. 1005+00 TO STA. 1019+00			

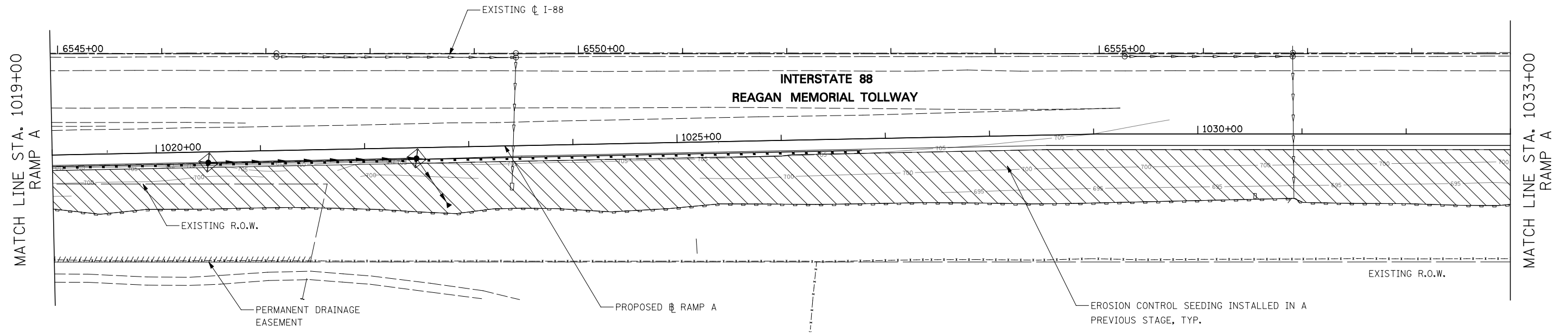

**EROSION CONTROL LEGEND**

	TEMPORARY EROSION CONTROL SEEDING AND TEMPORARY EROSION CONTROL BLANKET		TEMPORARY DITCH CHECK
	PERMANENT SEEDING (SEE NOTE 3)		TEMPORARY DITCH CHECK INSTALLED IN PREVIOUS STAGE
	TEMPORARY EROSION CONTROL SEEDING OR PERMANENT SEEDING INSTALLED IN A PREVIOUS STAGE		INLET & PIPE PROTECTION
	TEMPORARY PAVEMENT		INLET & PIPE PROTECTION INSTALLED IN PREVIOUS STAGE
	PERIMETER EROSION BARRIER (SEE NOTE 2)		FLOW DIRECTION (SEE NOTE 4)
	PERIMETER EROSION BARRIER INSTALLED IN PREVIOUS STAGE		PROPOSED STORM SEWER (SEE NOTE 1)
	INLET FILTER		PROPOSED STORM SEWER INSTALLED IN PREVIOUS STAGE
	INLET FILTER INSTALLED IN PREVIOUS STAGE		TEMPORARY PIPE CULVERT
	PERMANENT DRAINAGE STRUCTURE NUMBER (SEE NOTE 1)		

**NOTES**



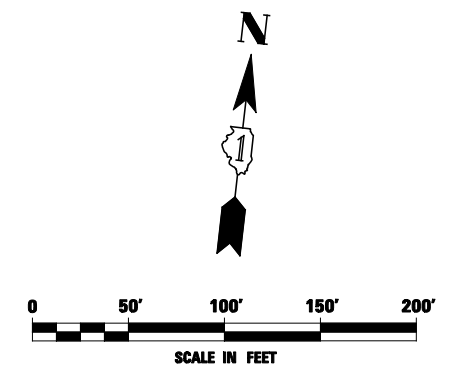



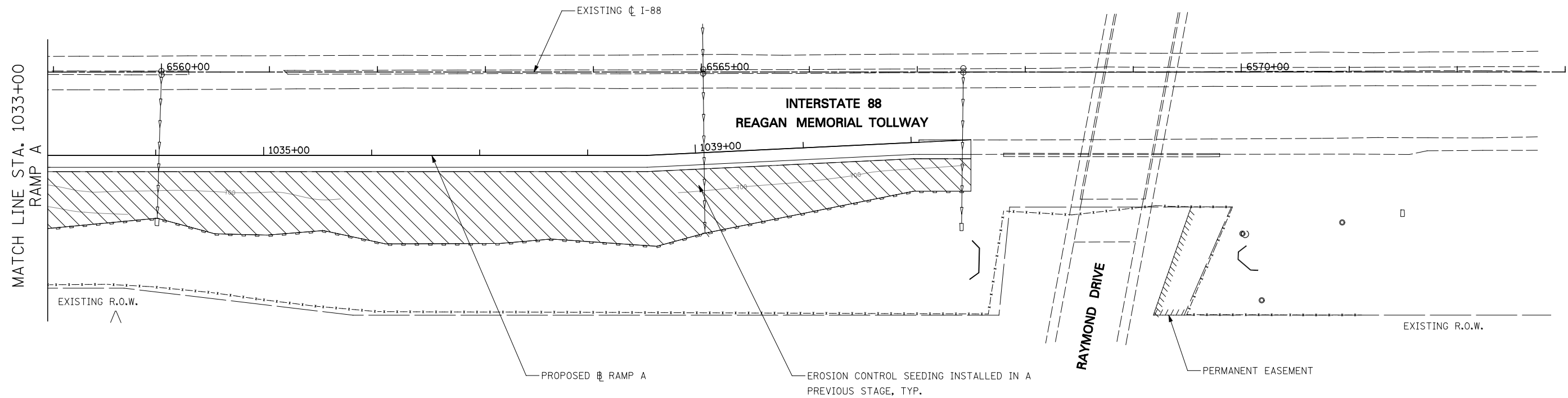



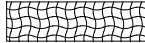

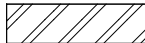

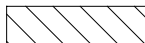

1. SEE PROPOSED DRAINAGE PLANS FOR STORM SEWER INFORMATION
2. PERIMETER EROSION BARRIER SHALL BE ERECTED ADJACENT TO R.O.W., EASEMENT, AND CONSTRUCTION LIMITS AND AS DIRECTED BY THE ENGINEER.
3. SEE LANDSCAPING PLANS FOR LANDSCAPING REQUIREMENTS.
4. SEE STAGE 3 CROSS SECTIONS FOR GRADING INFORMATION.

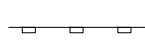

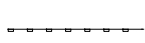
FILE NAME = #FILEL#	USER NAME = #USER#	DESIGNED <i>PJO</i>	REVISED -	<b>STATE OF ILLINOIS DEPARTMENT OF TRANSPORTATION</b>	<b>EROSION CONTROL - STAGE 3, 3A, 3B, AND 3C RAMP A</b>	F.A.P. RTE.	SECTION	COUNTY	TOTAL SHEETS	SHEET NO.	
		DRAWN <i>KES</i>	REVISED -			338	(112 & 113) WRS-5	DUPAGE	963	521	
		CHECKED <i>JCM</i>	REVISED -			CONTRACT NO. 60I31					
		DATE <i>10/15/2012</i>	REVISED -			ILLINOIS FED. AID PROJECT					
				SCALE:	SHEET NO. 46 OF 66 SHEETS	STA. 1019+00	TO STA. 1033+00				



**EROSION CONTROL LEGEND**

	TEMPORARY EROSION CONTROL SEEDING AND TEMPORARY EROSION CONTROL BLANKET		TEMPORARY DITCH CHECK
	PERMANENT SEEDING (SEE NOTE 3)		TEMPORARY DITCH CHECK INSTALLED IN PREVIOUS STAGE
	TEMPORARY EROSION CONTROL SEEDING OR PERMANENT SEEDING INSTALLED IN A PREVIOUS STAGE		INLET & PIPE PROTECTION
	TEMPORARY PAVEMENT		INLET & PIPE PROTECTION INSTALLED IN PREVIOUS STAGE
	PERIMETER EROSION BARRIER (SEE NOTE 2)		FLOW DIRECTION (SEE NOTE 4)
	PERIMETER EROSION BARRIER INSTALLED IN PREVIOUS STAGE		PROPOSED STORM SEWER (SEE NOTE 1)
	INLET FILTER		PROPOSED STORM SEWER INSTALLED IN PREVIOUS STAGE
	INLET FILTER INSTALLED IN PREVIOUS STAGE		TEMPORARY PIPE CULVERT
	PERMANENT DRAINAGE STRUCTURE NUMBER (SEE NOTE 1)		

**NOTES**



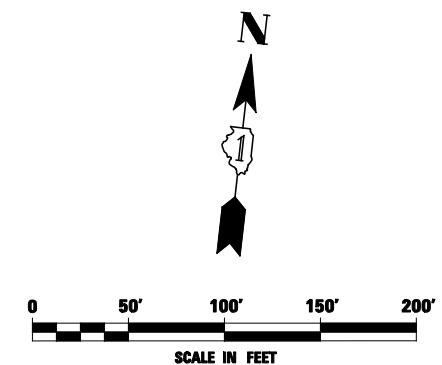



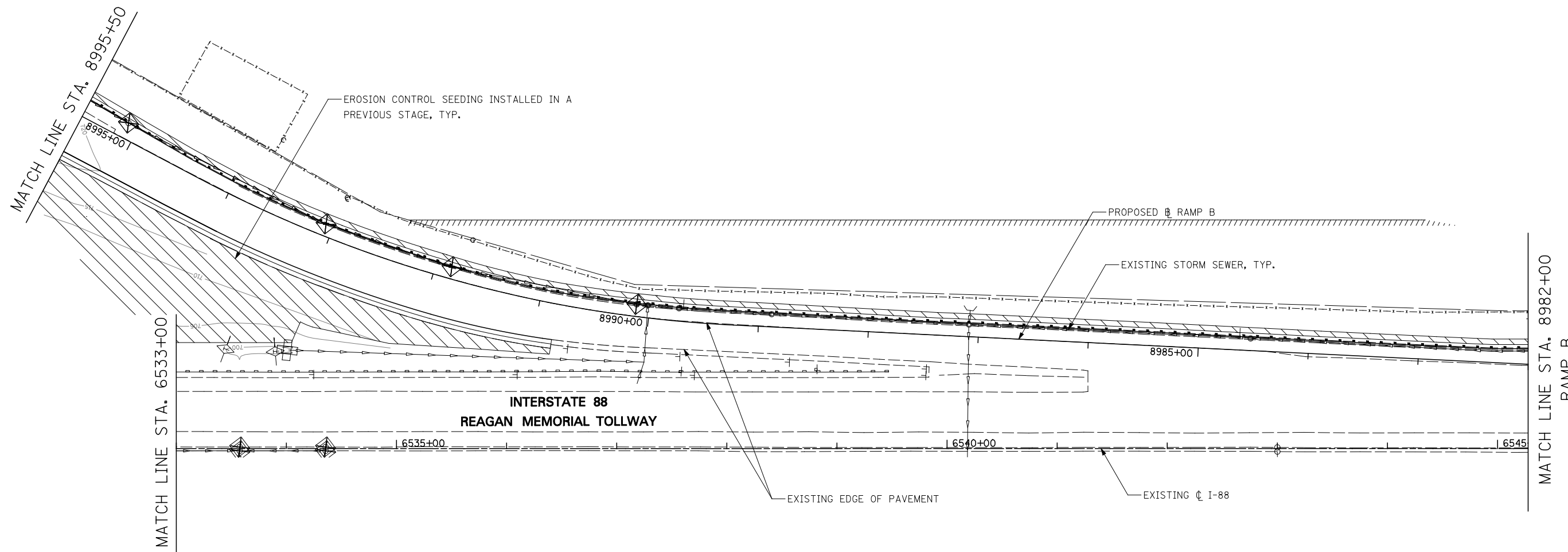



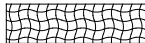



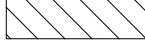

1. SEE PROPOSED DRAINAGE PLANS FOR STORM SEWER INFORMATION
2. PERIMETER EROSION BARRIER SHALL BE ERECTED ADJACENT TO R.O.W., EASEMENT, AND CONSTRUCTION LIMITS AND AS DIRECTED BY THE ENGINEER.
3. SEE LANDSCAPING PLANS FOR LANDSCAPING REQUIREMENTS.
4. SEE STAGE 3 CROSS SECTIONS FOR GRADING INFORMATION.

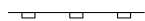

FILE NAME = #FILE#	USER NAME = #USER#	DESIGNED <i>PJO</i>	REVISED -	<b>STATE OF ILLINOIS DEPARTMENT OF TRANSPORTATION</b>	<b>EROSION CONTROL - STAGE 3, 3A, 3B, AND 3C RAMP A</b>	F.A.P. RTE.	SECTION	COUNTY	TOTAL SHEETS	SHEET NO.
	PLOT SCALE = #SCALE#	DRAWN <i>KES</i>	REVISED -			338	(112 & 113) WRS-5	DUPAGE	963	522
PLOT DATE = #DATE#	CHECKED <i>JCM</i>	DATE <i>10/15/2012</i>	REVISED -		CONTRACT NO. 60I31					
			REVISED -		SCALE:	SHEET NO. 47 OF 66 SHEETS	STA. 1033+00	TO STA. 1041+55	ILLINOIS FED. AID PROJECT	



**EROSION CONTROL LEGEND**

- |                                                                                     |                                                                                      |                                                                                     |                                                     |
|-------------------------------------------------------------------------------------|--------------------------------------------------------------------------------------|-------------------------------------------------------------------------------------|-----------------------------------------------------|
|  | TEMPORARY EROSION CONTROL SEEDING AND TEMPORARY EROSION CONTROL BLANKET              |  | TEMPORARY DITCH CHECK                               |
|  | PERMANENT SEEDING (SEE NOTE 3)                                                       |  | TEMPORARY DITCH CHECK INSTALLED IN PREVIOUS STAGE   |
|  | TEMPORARY EROSION CONTROL SEEDING OR PERMANENT SEEDING INSTALLED IN A PREVIOUS STAGE |  | INLET & PIPE PROTECTION                             |
|  | TEMPORARY PAVEMENT                                                                   |  | INLET & PIPE PROTECTION INSTALLED IN PREVIOUS STAGE |
|  | PERIMETER EROSION BARRIER (SEE NOTE 2)                                               |  | FLOW DIRECTION (SEE NOTE 4)                         |
|  | PERIMETER EROSION BARRIER INSTALLED IN PREVIOUS STAGE                                |  | PROPOSED STORM SEWER (SEE NOTE 1)                   |
|  | INLET FILTER                                                                         |  | PROPOSED STORM SEWER INSTALLED IN PREVIOUS STAGE    |
|  | INLET FILTER INSTALLED IN PREVIOUS STAGE                                             |  | TEMPORARY PIPE CULVERT                              |
|  | PERMANENT DRAINAGE STRUCTURE NUMBER (SEE NOTE 1)                                     |                                                                                     |                                                     |

**NOTES**

1. SEE PROPOSED DRAINAGE PLANS FOR STORM SEWER INFORMATION
2. PERIMETER EROSION BARRIER SHALL BE ERECTED ADJACENT TO R.O.W., EASEMENT, AND CONSTRUCTION LIMITS AND AS DIRECTED BY THE ENGINEER.
3. SEE LANDSCAPING PLANS FOR LANDSCAPING REQUIREMENTS.
4. SEE STAGE 3 CROSS SECTIONS FOR GRADING INFORMATION.

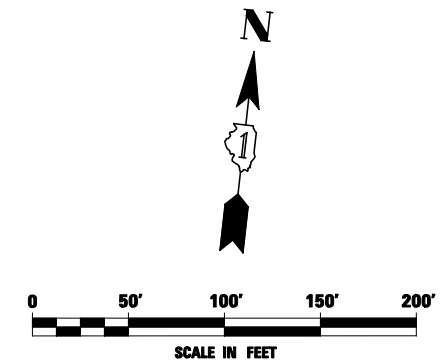

FILE NAME = #FILEL#	USER NAME = #USER#	DESIGNED <i>PJO</i>	REVISED -	<b>STATE OF ILLINOIS DEPARTMENT OF TRANSPORTATION</b>	<b>EROSION CONTROL - STAGE 3, 3A, 3B, AND 3C RAMP B</b>	F.A.P. RTE.	SECTION	COUNTY	TOTAL SHEETS	SHEET NO.	
		DRAWN <i>KES</i>	REVISED -			338	(112 & 113) WRS-5	DUPAGE	963	523	
		CHECKED <i>JCM</i>	REVISED -			CONTRACT NO. 60I31					
		DATE <i>10/15/2012</i>	REVISED -			SCALE:	SHEET NO. 48 OF 66 SHEETS	STA. 8982+00 TO STA. 8995+50	ILLINOIS FED. AID PROJECT		

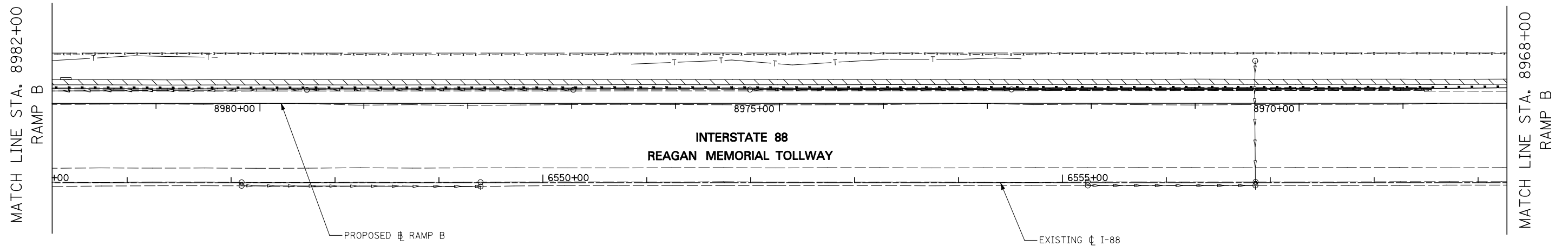

**EROSION CONTROL LEGEND**

	TEMPORARY EROSION CONTROL SEEDING AND TEMPORARY EROSION CONTROL BLANKET		TEMPORARY DITCH CHECK
	PERMANENT SEEDING (SEE NOTE 3)		TEMPORARY DITCH CHECK INSTALLED IN PREVIOUS STAGE
	TEMPORARY EROSION CONTROL SEEDING OR PERMANENT SEEDING INSTALLED IN A PREVIOUS STAGE		INLET & PIPE PROTECTION
	TEMPORARY PAVEMENT		INLET & PIPE PROTECTION INSTALLED IN PREVIOUS STAGE
	PERIMETER EROSION BARRIER (SEE NOTE 2)		FLOW DIRECTION (SEE NOTE 4)
	PERIMETER EROSION BARRIER INSTALLED IN PREVIOUS STAGE		PROPOSED STORM SEWER (SEE NOTE 1)
	INLET FILTER		PROPOSED STORM SEWER INSTALLED IN PREVIOUS STAGE
	INLET FILTER INSTALLED IN PREVIOUS STAGE		TEMPORARY PIPE CULVERT
	PERMANENT DRAINAGE STRUCTURE NUMBER (SEE NOTE 1)		

**NOTES**

1. SEE PROPOSED DRAINAGE PLANS FOR STORM SEWER INFORMATION
2. PERIMETER EROSION BARRIER SHALL BE ERECTED ADJACENT TO R.O.W., EASEMENT, AND CONSTRUCTION LIMITS AND AS DIRECTED BY THE ENGINEER.
3. SEE LANDSCAPING PLANS FOR LANDSCAPING REQUIREMENTS.
4. SEE STAGE 3 CROSS SECTIONS FOR GRADING INFORMATION.

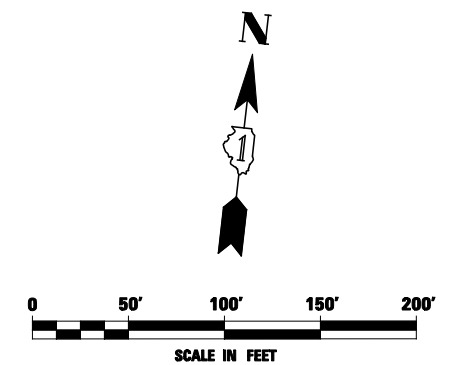

FILE NAME = #FILEL#	USER NAME = #USER#	DESIGNED <i>PJO</i>	REVISED -	<b>STATE OF ILLINOIS DEPARTMENT OF TRANSPORTATION</b>	<b>EROSION CONTROL - STAGE 3, 3A, 3B, AND 3C RAMP B</b>	F.A.P. RTE.	SECTION	COUNTY	TOTAL SHEETS	SHEET NO.	
		DRAWN <i>KES</i>	REVISED -			338	(112 & 113) WRS-5	DUPAGE	963	524	
		CHECKED <i>JCM</i>	REVISED -			CONTRACT NO. 60I31					
		DATE <i>10/15/2012</i>	REVISED -			ILLINOIS FED. AID PROJECT					
				SCALE:	SHEET NO. 49 OF 66 SHEETS	STA. 8968+00	TO STA. 8982+00				



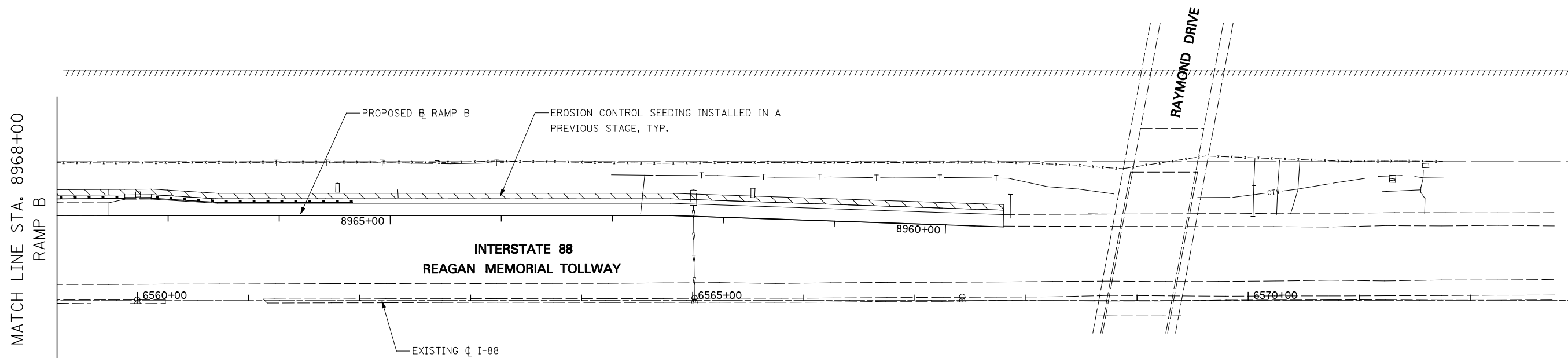

**EROSION CONTROL LEGEND**

	TEMPORARY EROSION CONTROL SEEDING AND TEMPORARY EROSION CONTROL BLANKET		TEMPORARY DITCH CHECK
	PERMANENT SEEDING (SEE NOTE 3)		TEMPORARY DITCH CHECK INSTALLED IN PREVIOUS STAGE
	TEMPORARY EROSION CONTROL SEEDING OR PERMANENT SEEDING INSTALLED IN A PREVIOUS STAGE		INLET & PIPE PROTECTION
	TEMPORARY PAVEMENT		INLET & PIPE PROTECTION INSTALLED IN PREVIOUS STAGE
	PERIMETER EROSION BARRIER (SEE NOTE 2)		FLOW DIRECTION (SEE NOTE 4)
	PERIMETER EROSION BARRIER INSTALLED IN PREVIOUS STAGE		PROPOSED STORM SEWER (SEE NOTE 1)
	INLET FILTER		PROPOSED STORM SEWER INSTALLED IN PREVIOUS STAGE
	INLET FILTER INSTALLED IN PREVIOUS STAGE		TEMPORARY PIPE CULVERT
	PERMANENT DRAINAGE STRUCTURE NUMBER (SEE NOTE 1)		

**NOTES**

- SEE PROPOSED DRAINAGE PLANS FOR STORM SEWER INFORMATION
- PERIMETER EROSION BARRIER SHALL BE ERECTED ADJACENT TO R.O.W., EASEMENT, AND CONSTRUCTION LIMITS AND AS DIRECTED BY THE ENGINEER.
- SEE LANDSCAPING PLANS FOR LANDSCAPING REQUIREMENTS.
- SEE STAGE 3 CROSS SECTIONS FOR GRADING INFORMATION.

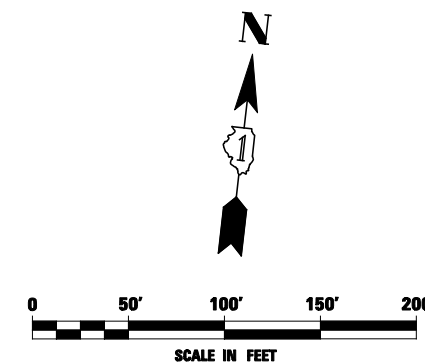

FILE NAME = #FILE#	USER NAME = #USER#	DESIGNED <i>PJO</i>	REVISED -	<b>STATE OF ILLINOIS DEPARTMENT OF TRANSPORTATION</b>	<b>EROSION CONTROL - STAGE 3, 3A, 3B, AND 3C RAMP B</b>	F.A.P. RTE.	SECTION	COUNTY	TOTAL SHEETS	SHEET NO.	
		DRAWN <i>KES</i>	REVISED -			338	(112 & 113) WRS-5	DUPAGE	963	525	
		CHECKED <i>JCM</i>	REVISED -			CONTRACT NO. 60I31					
		DATE <i>10/15/2012</i>	REVISED -			ILLINOIS FED. AID PROJECT					
				SCALE:	SHEET NO. 50 OF 66 SHEETS	STA. 8959+48	TO STA. 8968+00				

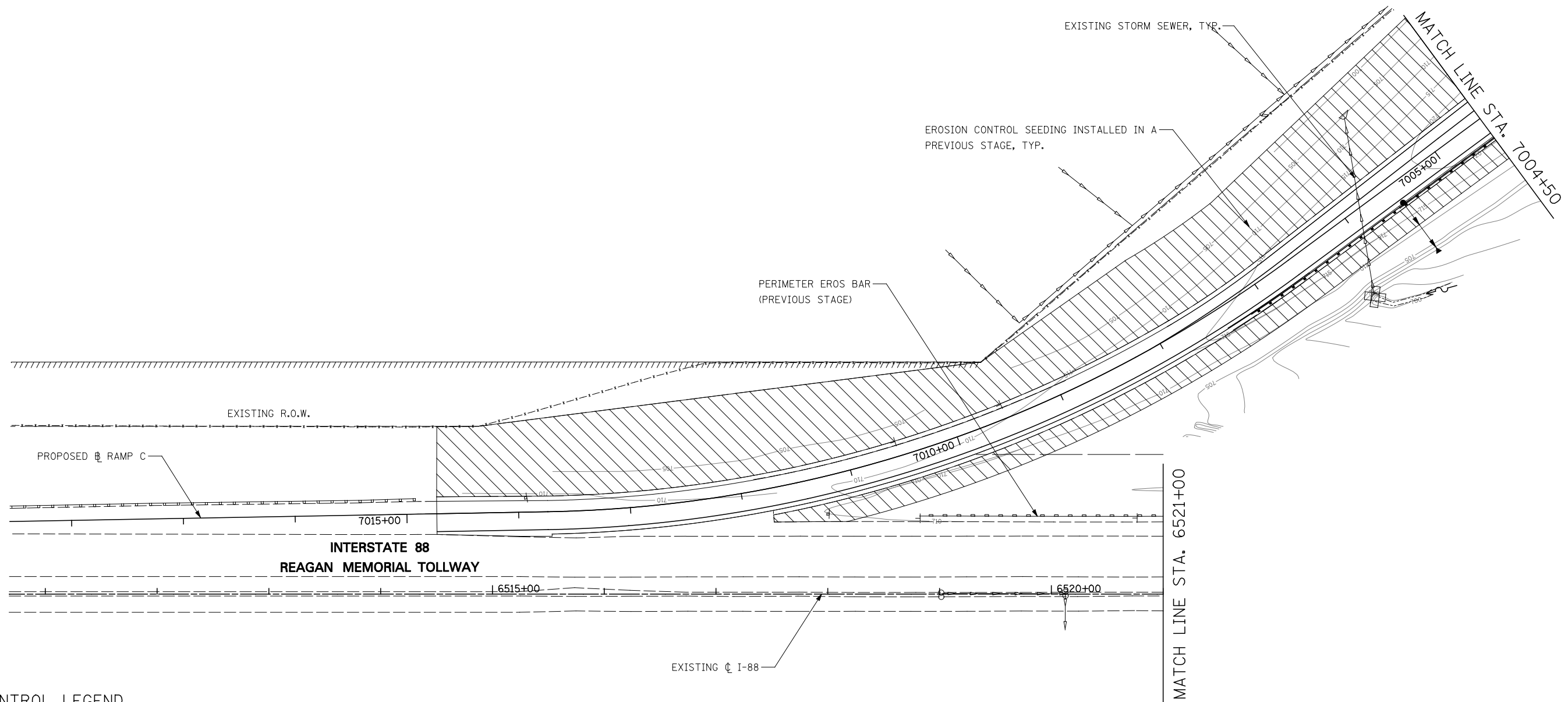

**EROSION CONTROL LEGEND**

	TEMPORARY EROSION CONTROL SEEDING AND TEMPORARY EROSION CONTROL BLANKET		TEMPORARY DITCH CHECK
	PERMANENT SEEDING (SEE NOTE 3)		TEMPORARY DITCH CHECK INSTALLED IN PREVIOUS STAGE
	TEMPORARY EROSION CONTROL SEEDING OR PERMANENT SEEDING INSTALLED IN A PREVIOUS STAGE		INLET & PIPE PROTECTION
	TEMPORARY PAVEMENT		INLET & PIPE PROTECTION INSTALLED IN PREVIOUS STAGE
	PERIMETER EROSION BARRIER (SEE NOTE 2)		FLOW DIRECTION (SEE NOTE 4)
	PERIMETER EROSION BARRIER INSTALLED IN PREVIOUS STAGE		PROPOSED STORM SEWER (SEE NOTE 1)
	INLET FILTER		PROPOSED STORM SEWER INSTALLED IN PREVIOUS STAGE
	INLET FILTER INSTALLED IN PREVIOUS STAGE		TEMPORARY PIPE CULVERT
	PERMANENT DRAINAGE STRUCTURE NUMBER (SEE NOTE 1)		

**NOTES**

- SEE PROPOSED DRAINAGE PLANS FOR STORM SEWER INFORMATION
- PERIMETER EROSION BARRIER SHALL BE ERECTED ADJACENT TO R.O.W., EASEMENT, AND CONSTRUCTION LIMITS AND AS DIRECTED BY THE ENGINEER.
- SEE LANDSCAPING PLANS FOR LANDSCAPING REQUIREMENTS.
- SEE STAGE 3 CROSS SECTIONS FOR GRADING INFORMATION.

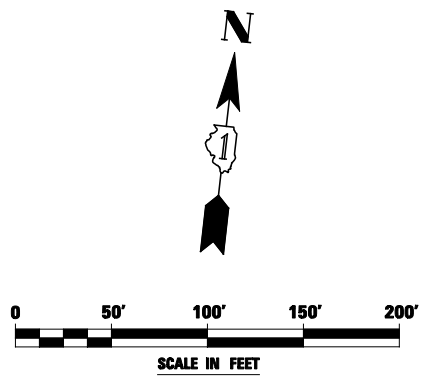

FILE NAME =	USER NAME = #USER#	DESIGNED <i>PJO</i>	REVISED -
#FILEL#		DRAWN <i>KES</i>	REVISED -
	PLOT SCALE = #SCALE#	CHECKED <i>JCM</i>	REVISED -
	PLOT DATE = #DATE#	DATE <i>10/15/2012</i>	REVISED -

**STATE OF ILLINOIS  
DEPARTMENT OF TRANSPORTATION**

**EROSION CONTROL - STAGE 3, 3A, 3B, AND 3C  
RAMP C**

SCALE: SHEET NO. 51 OF 66 SHEETS STA. 7004+50 TO STA. 7018+55

F.A.P. RTE.	SECTION	COUNTY	TOTAL SHEETS	SHEET NO.
338	(112 & 113) WRS-5	DUPAGE	963	526
CONTRACT NO. 60I31				
ILLINOIS FED. AID PROJECT				

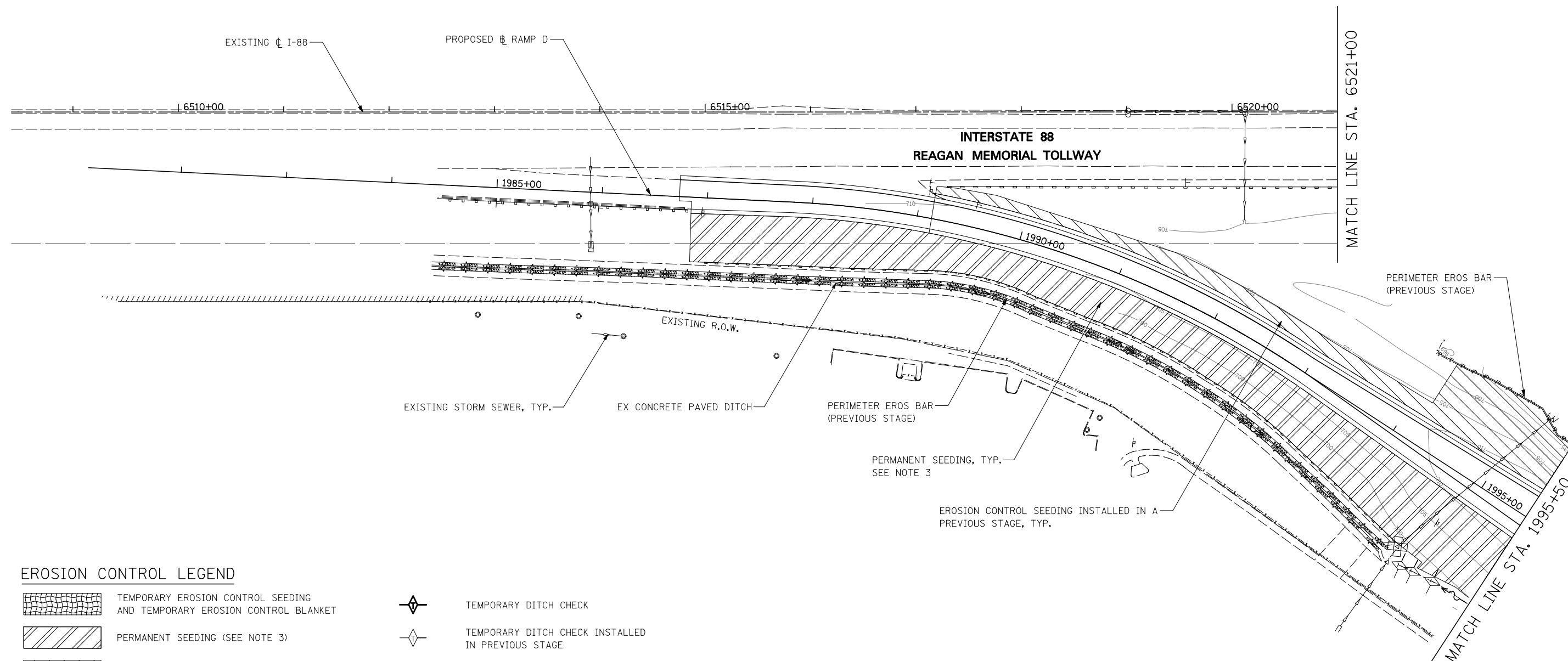

**EROSION CONTROL LEGEND**

- |  |                                                                                      |  |                                                     |
|--|--------------------------------------------------------------------------------------|--|-----------------------------------------------------|
|  | TEMPORARY EROSION CONTROL SEEDING AND TEMPORARY EROSION CONTROL BLANKET              |  | TEMPORARY DITCH CHECK                               |
|  | PERMANENT SEEDING (SEE NOTE 3)                                                       |  | TEMPORARY DITCH CHECK INSTALLED IN PREVIOUS STAGE   |
|  | TEMPORARY EROSION CONTROL SEEDING OR PERMANENT SEEDING INSTALLED IN A PREVIOUS STAGE |  | INLET & PIPE PROTECTION                             |
|  | TEMPORARY PAVEMENT                                                                   |  | INLET & PIPE PROTECTION INSTALLED IN PREVIOUS STAGE |
|  | PERIMETER EROSION BARRIER (SEE NOTE 2)                                               |  | FLOW DIRECTION (SEE NOTE 4)                         |
|  | PERIMETER EROSION BARRIER INSTALLED IN PREVIOUS STAGE                                |  | PROPOSED STORM SEWER (SEE NOTE 1)                   |
|  | INLET FILTER                                                                         |  | PROPOSED STORM SEWER INSTALLED IN PREVIOUS STAGE    |
|  | INLET FILTER INSTALLED IN PREVIOUS STAGE                                             |  | TEMPORARY PIPE CULVERT                              |
|  | PERMANENT DRAINAGE STRUCTURE NUMBER (SEE NOTE 1)                                     |  |                                                     |

**NOTES**

- SEE PROPOSED DRAINAGE PLANS FOR STORM SEWER INFORMATION
- PERIMETER EROSION BARRIER SHALL BE ERECTED ADJACENT TO R.O.W., EASEMENT, AND CONSTRUCTION LIMITS AND AS DIRECTED BY THE ENGINEER.
- SEE LANDSCAPING PLANS FOR LANDSCAPING REQUIREMENTS.
- SEE STAGE 3 CROSS SECTIONS FOR GRADING INFORMATION.

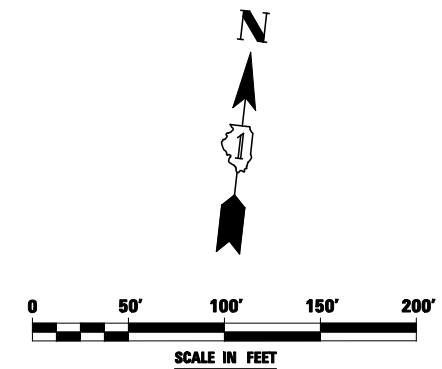

FILE NAME = #FILEL#	USER NAME = #USER#	DESIGNED <i>PJO</i>	REVISED -	<b>STATE OF ILLINOIS DEPARTMENT OF TRANSPORTATION</b>	<b>EROSION CONTROL - STAGE 3, 3A, 3B, AND 3C RAMP D</b>	F.A.P. RTE.	SECTION	COUNTY	TOTAL SHEETS	SHEET NO.	
		DRAWN <i>KES</i>	REVISED -			338	(112 & 113) WRS-5	DUPAGE	963	527	
		CHECKED <i>JCM</i>	REVISED -			CONTRACT NO. 60I31					
		DATE <i>10/15/2012</i>	REVISED -			ILLINOIS FED. AID PROJECT					
				SCALE:	SHEET NO. 52 OF 66 SHEETS	STA. 1981+22	TO STA. 1995+50				

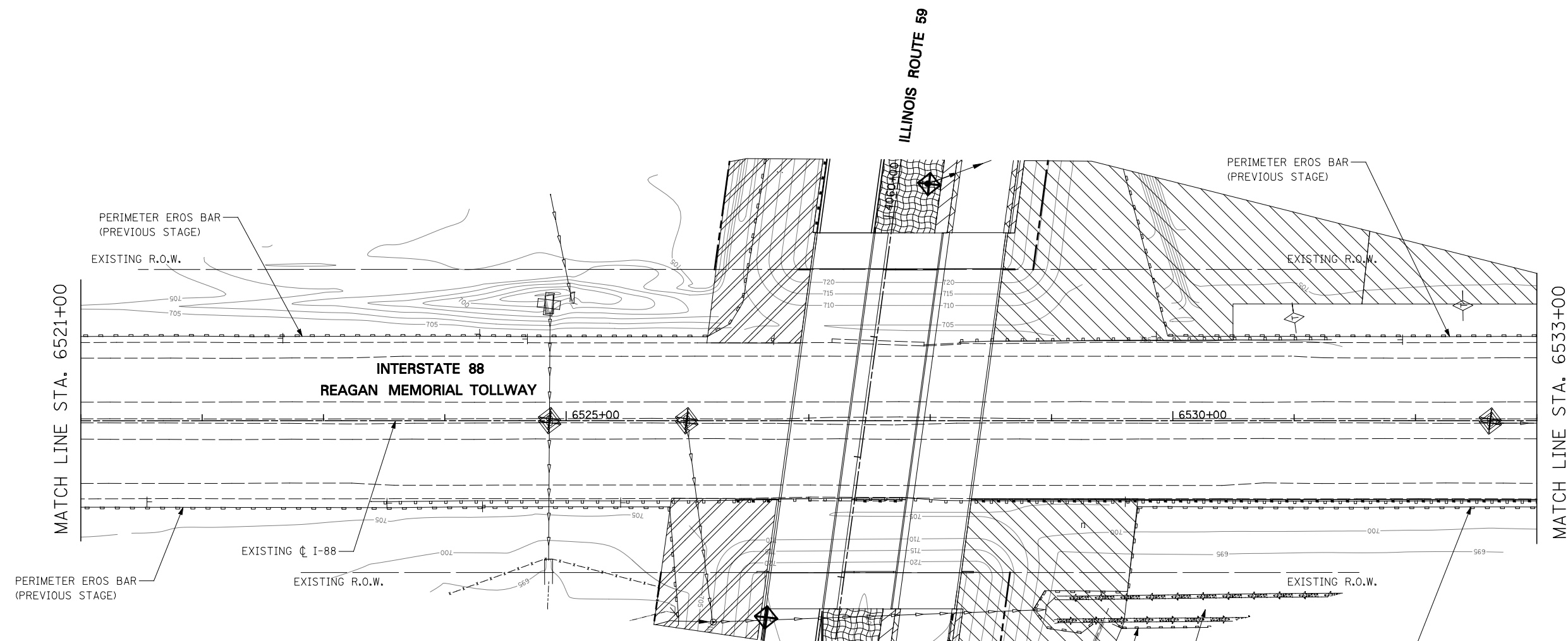

**EROSION CONTROL LEGEND**

- |  |                                                                                      |  |                                                     |
|--|--------------------------------------------------------------------------------------|--|-----------------------------------------------------|
|  | TEMPORARY EROSION CONTROL SEEDING AND TEMPORARY EROSION CONTROL BLANKET              |  | TEMPORARY DITCH CHECK                               |
|  | PERMANENT SEEDING (SEE NOTE 3)                                                       |  | TEMPORARY DITCH CHECK INSTALLED IN PREVIOUS STAGE   |
|  | TEMPORARY EROSION CONTROL SEEDING OR PERMANENT SEEDING INSTALLED IN A PREVIOUS STAGE |  | INLET & PIPE PROTECTION                             |
|  | TEMPORARY PAVEMENT                                                                   |  | INLET & PIPE PROTECTION INSTALLED IN PREVIOUS STAGE |
|  | PERIMETER EROSION BARRIER (SEE NOTE 2)                                               |  | FLOW DIRECTION (SEE NOTE 4)                         |
|  | PERIMETER EROSION BARRIER INSTALLED IN PREVIOUS STAGE                                |  | PROPOSED STORM SEWER (SEE NOTE 1)                   |
|  | INLET FILTER                                                                         |  | PROPOSED STORM SEWER INSTALLED IN PREVIOUS STAGE    |
|  | INLET FILTER INSTALLED IN PREVIOUS STAGE                                             |  | TEMPORARY PIPE CULVERT                              |
|  | PERMANENT DRAINAGE STRUCTURE NUMBER (SEE NOTE 1)                                     |  |                                                     |

**NOTES**

- SEE PROPOSED DRAINAGE PLANS FOR STORM SEWER INFORMATION
- PERIMETER EROSION BARRIER SHALL BE ERECTED ADJACENT TO R.O.W., EASEMENT, AND CONSTRUCTION LIMITS AND AS DIRECTED BY THE ENGINEER.
- SEE LANDSCAPING PLANS FOR LANDSCAPING REQUIREMENTS.
- SEE STAGE 3 CROSS SECTIONS FOR GRADING INFORMATION.

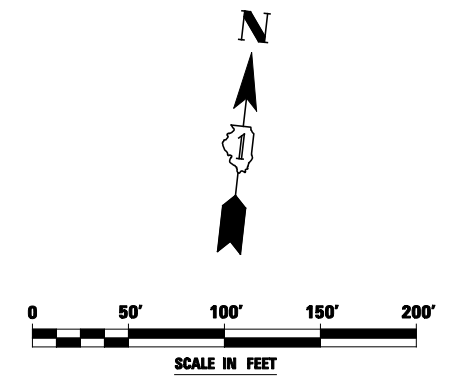

FILE NAME = #FILEL#	USER NAME = #USER#	DESIGNED <i>PJO</i>	REVISED -	<b>STATE OF ILLINOIS DEPARTMENT OF TRANSPORTATION</b>	<b>EROSION CONTROL - STAGE 3, 3A, 3B, AND 3C INTERSTATE 88</b>	F.A.P. RTE.	SECTION	COUNTY	TOTAL SHEETS	SHEET NO.	
		DRAWN <i>KES</i>	REVISED -			338	(112 & 113) WRS-5	DUPAGE	963	528	
		CHECKED <i>JCM</i>	REVISED -			CONTRACT NO. 60I31					
		DATE <i>10/15/2012</i>	REVISED -			ILLINOIS FED. AID PROJECT					
				SCALE:	SHEET NO. 53 OF 66 SHEETS	STA. 6521+00 TO STA. 6533+00					

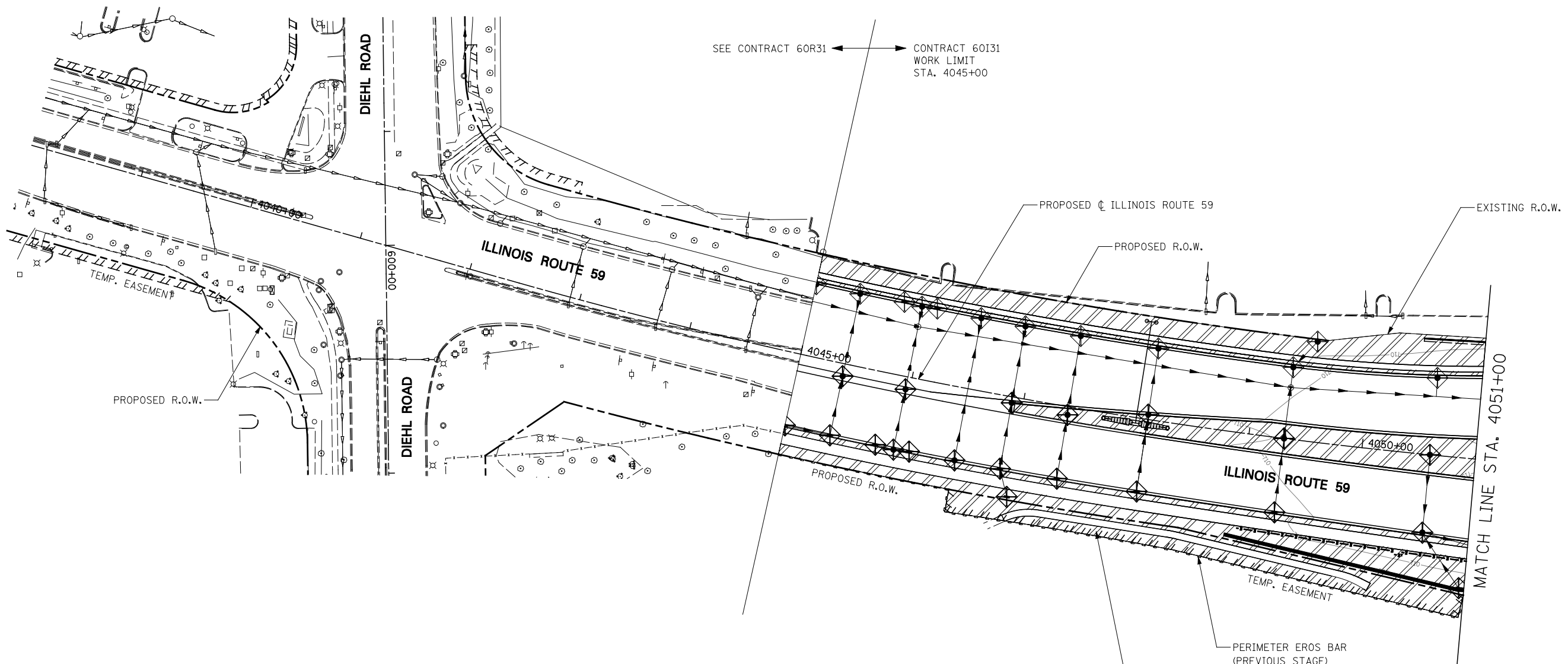

SEE CONTRACT 60R31 ← CONTRACT 60I31  
 WORK LIMIT  
 STA. 4045+00

**EROSION CONTROL LEGEND**

- |  |                                                                                      |  |                                                     |
|--|--------------------------------------------------------------------------------------|--|-----------------------------------------------------|
|  | TEMPORARY EROSION CONTROL SEEDING AND TEMPORARY EROSION CONTROL BLANKET              |  | TEMPORARY DITCH CHECK                               |
|  | PERMANENT SEEDING (SEE NOTE 3)                                                       |  | TEMPORARY DITCH CHECK INSTALLED IN PREVIOUS STAGE   |
|  | TEMPORARY EROSION CONTROL SEEDING OR PERMANENT SEEDING INSTALLED IN A PREVIOUS STAGE |  | INLET & PIPE PROTECTION                             |
|  | TEMPORARY PAVEMENT                                                                   |  | INLET & PIPE PROTECTION INSTALLED IN PREVIOUS STAGE |
|  | PERIMETER EROSION BARRIER (SEE NOTE 2)                                               |  | FLOW DIRECTION (SEE NOTE 4)                         |
|  | PERIMETER EROSION BARRIER INSTALLED IN PREVIOUS STAGE                                |  | PROPOSED STORM SEWER (SEE NOTE 1)                   |
|  | INLET FILTER                                                                         |  | PROPOSED STORM SEWER INSTALLED IN PREVIOUS STAGE    |
|  | INLET FILTER INSTALLED IN PREVIOUS STAGE                                             |  | TEMPORARY PIPE CULVERT                              |
|  | PERMANENT DRAINAGE STRUCTURE NUMBER (SEE NOTE 1)                                     |  |                                                     |

**NOTES**

- SEE PROPOSED DRAINAGE PLANS FOR STORM SEWER INFORMATION
- PERIMETER EROSION BARRIER SHALL BE ERECTED ADJACENT TO R.O.W., EASEMENT, AND CONSTRUCTION LIMITS AND AS DIRECTED BY THE ENGINEER.
- SEE LANDSCAPING PLANS FOR LANDSCAPING REQUIREMENTS.
- SEE STAGE 4 CROSS SECTIONS FOR GRADING INFORMATION.

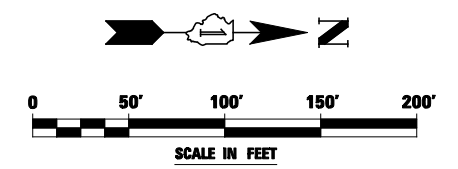

FILE NAME = #FILE#	USER NAME = #USER#	DESIGNED <i>PJO</i>	REVISED -	<b>STATE OF ILLINOIS DEPARTMENT OF TRANSPORTATION</b>	<b>EROSION CONTROL - STAGE 4, 4A AND 4B ILLINOIS ROUTE 59</b>	F.A.P. RTE.	SECTION	COUNTY	TOTAL SHEETS	SHEET NO.	
		DRAWN <i>KES</i>	REVISED -			338	(112 & 113) WRS-5	DUPAGE	963	529	
		CHECKED <i>JCM</i>	REVISED -			CONTRACT NO. 60I31					
		DATE <i>10/15/2012</i>	REVISED -			ILLINOIS FED. AID PROJECT					
				SCALE:	SHEET NO. 54 OF 66 SHEETS	STA. 4045+00 TO STA. 4051+00					

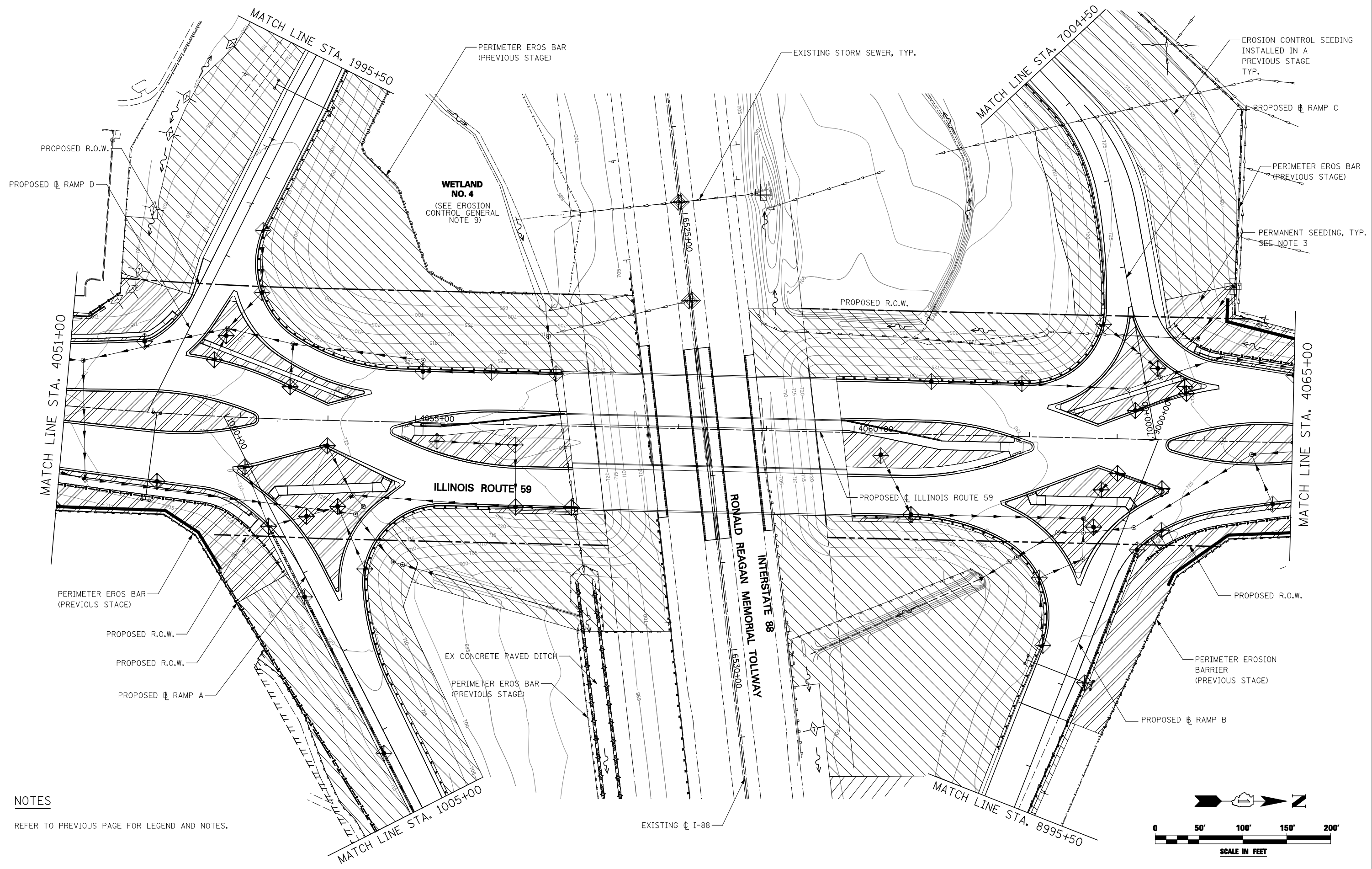

**NOTES**

REFER TO PREVIOUS PAGE FOR LEGEND AND NOTES.

FILE NAME = #FILE#	USER NAME = #USER#	DESIGNED <i>PJO</i>	REVISED -
		DRAWN <i>KES</i>	REVISED -
		CHECKED <i>JCM</i>	REVISED -
		DATE <i>10/15/2012</i>	REVISED -











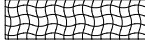

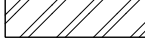

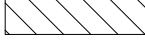

**STATE OF ILLINOIS  
DEPARTMENT OF TRANSPORTATION**

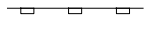
**EROSION CONTROL - STAGE 4, 4A AND 4B  
ILLINOIS ROUTE 59**

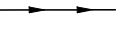
SCALE: SHEET NO. 55 OF 66 SHEETS STA. 4051+00 TO STA. 4065+00

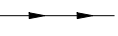
F.A.P. RTE.	SECTION	COUNTY	TOTAL SHEETS	SHEET NO.
338	(112 & 113) WRS-5	DUPAGE	963	530
CONTRACT NO. 60131				
ILLINOIS FED. AID PROJECT				

**EROSION CONTROL LEGEND**

	TEMPORARY EROSION CONTROL SEEDING AND TEMPORARY EROSION CONTROL BLANKET		TEMPORARY DITCH CHECK
	PERMANENT SEEDING (SEE NOTE 3)		TEMPORARY DITCH CHECK INSTALLED IN PREVIOUS STAGE
	TEMPORARY EROSION CONTROL SEEDING OR PERMANENT SEEDING INSTALLED IN A PREVIOUS STAGE		INLET & PIPE PROTECTION
	TEMPORARY PAVEMENT		INLET & PIPE PROTECTION INSTALLED IN PREVIOUS STAGE
	PERIMETER EROSION BARRIER (SEE NOTE 2)		FLOW DIRECTION (SEE NOTE 4)
	PERIMETER EROSION BARRIER INSTALLED IN PREVIOUS STAGE		PROPOSED STORM SEWER (SEE NOTE 1)
	INLET FILTER		PROPOSED STORM SEWER INSTALLED IN PREVIOUS STAGE
	INLET FILTER INSTALLED IN PREVIOUS STAGE		TEMPORARY PIPE CULVERT
	PERMANENT DRAINAGE STRUCTURE NUMBER (SEE NOTE 1)		





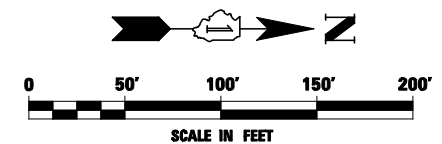
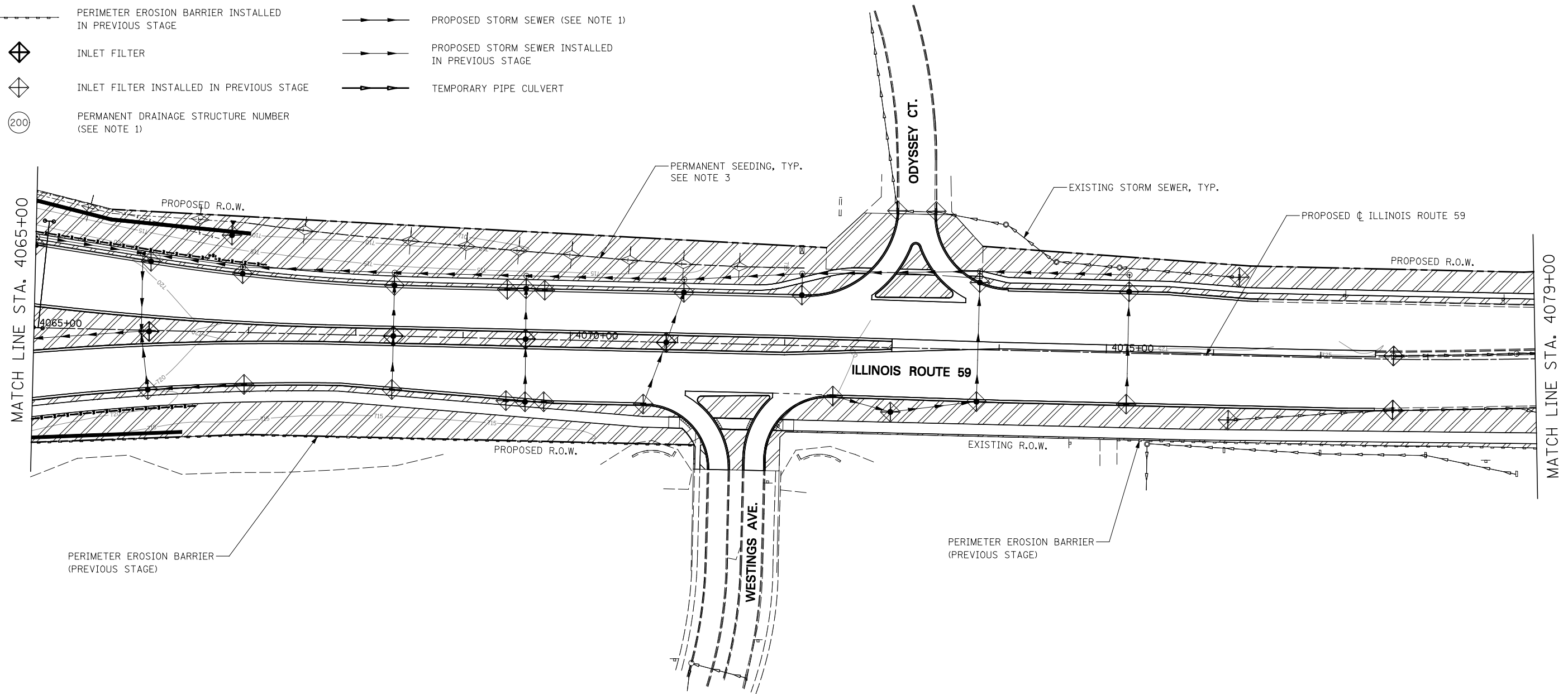





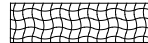



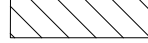

**NOTES**

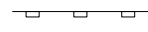
1. SEE PROPOSED DRAINAGE PLANS FOR STORM SEWER INFORMATION
2. PERIMETER EROSION BARRIER SHALL BE ERECTED ADJACENT TO R.O.W., EASEMENT, AND CONSTRUCTION LIMITS AND AS DIRECTED BY THE ENGINEER.
3. SEE LANDSCAPING PLANS FOR LANDSCAPING REQUIREMENTS.
4. SEE STAGE 4 CROSS SECTIONS FOR GRADING INFORMATION.



FILE NAME = #FILE#	USER NAME = #USER#	DESIGNED <i>PJO</i>	REVISED -	<b>STATE OF ILLINOIS DEPARTMENT OF TRANSPORTATION</b>	<b>EROSION CONTROL - STAGE 4, 4A AND 4B ILLINOIS ROUTE 59</b>	F.A.P. RTE.	SECTION	COUNTY	TOTAL SHEETS	SHEET NO.	
		DRAWN <i>KES</i>	REVISED -			338	(112 & 113) WRS-5	DUPAGE	963	531	
		CHECKED <i>JCM</i>	REVISED -			CONTRACT NO. 60I31					
		DATE <i>10/15/2012</i>	REVISED -			ILLINOIS FED. AID PROJECT					
				SCALE:		SHEET NO. 56 OF 66 SHEETS		STA. 4065+00 TO STA. 4079+00			

**EROSION CONTROL LEGEND**

	TEMPORARY EROSION CONTROL SEEDING AND TEMPORARY EROSION CONTROL BLANKET		TEMPORARY DITCH CHECK
	PERMANENT SEEDING (SEE NOTE 3)		TEMPORARY DITCH CHECK INSTALLED IN PREVIOUS STAGE
	TEMPORARY EROSION CONTROL SEEDING OR PERMANENT SEEDING INSTALLED IN A PREVIOUS STAGE		INLET & PIPE PROTECTION
	TEMPORARY PAVEMENT		INLET & PIPE PROTECTION INSTALLED IN PREVIOUS STAGE
	PERIMETER EROSION BARRIER (SEE NOTE 2)		FLOW DIRECTION (SEE NOTE 4)
	PERIMETER EROSION BARRIER INSTALLED IN PREVIOUS STAGE		PROPOSED STORM SEWER (SEE NOTE 1)
	INLET FILTER		PROPOSED STORM SEWER INSTALLED IN PREVIOUS STAGE
	INLET FILTER INSTALLED IN PREVIOUS STAGE		TEMPORARY PIPE CULVERT
	PERMANENT DRAINAGE STRUCTURE NUMBER (SEE NOTE 1)		

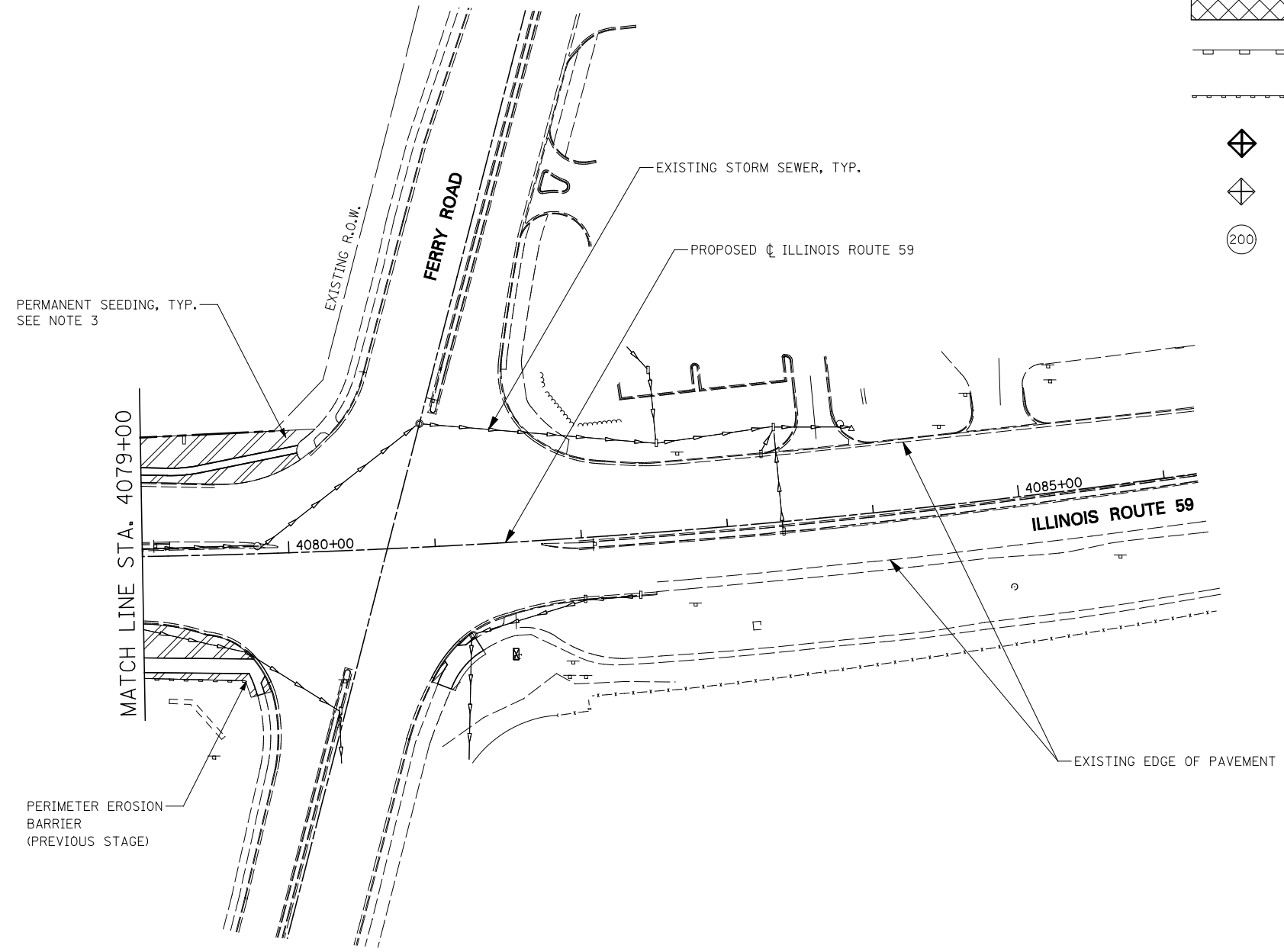

**NOTES**

1. SEE PROPOSED DRAINAGE PLANS FOR STORM SEWER INFORMATION
2. PERIMETER EROSION BARRIER SHALL BE ERECTED ADJACENT TO R.O.W., EASEMENT, AND CONSTRUCTION LIMITS AND AS DIRECTED BY THE ENGINEER.
3. SEE LANDSCAPING PLANS FOR LANDSCAPING REQUIREMENTS.
4. SEE STAGE 4 CROSS SECTIONS FOR GRADING INFORMATION.

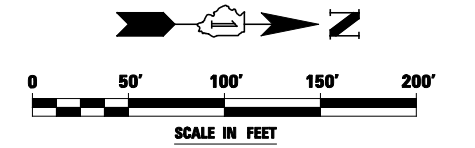

FILE NAME = *FILEL*	USER NAME = *USER*	DESIGNED <i>PJO</i>	REVISED -	<b>STATE OF ILLINOIS DEPARTMENT OF TRANSPORTATION</b>	<b>EROSION CONTROL - STAGE 4, 4A AND 4B ILLINOIS ROUTE 59</b>	F.A.P. RTE.	SECTION	COUNTY	TOTAL SHEETS	SHEET NO.	
		DRAWN <i>KES</i>	REVISED -			338	(112 & 113) WRS-5	DUPAGE	963	532	
		CHECKED <i>JCM</i>	REVISED -			CONTRACT NO. 60I31					
		DATE <i>10/15/2012</i>	REVISED -			SCALE:	SHEET NO. 57 OF 66 SHEETS	STA. 4079+00 TO STA. 4086+00	ILLINOIS FED. AID PROJECT		



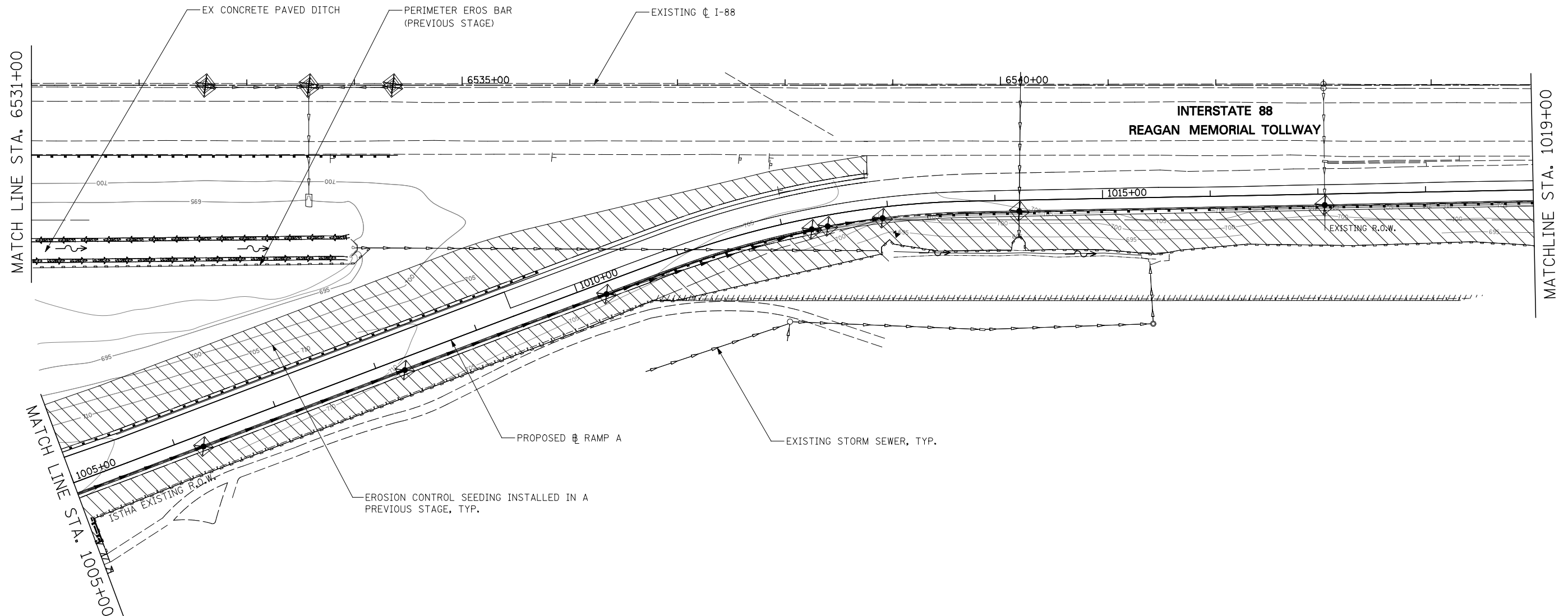

**EROSION CONTROL LEGEND**

- |  |                                                                                      |  |                                                     |
|--|--------------------------------------------------------------------------------------|--|-----------------------------------------------------|
|  | TEMPORARY EROSION CONTROL SEEDING AND TEMPORARY EROSION CONTROL BLANKET              |  | TEMPORARY DITCH CHECK                               |
|  | PERMANENT SEEDING (SEE NOTE 3)                                                       |  | TEMPORARY DITCH CHECK INSTALLED IN PREVIOUS STAGE   |
|  | TEMPORARY EROSION CONTROL SEEDING OR PERMANENT SEEDING INSTALLED IN A PREVIOUS STAGE |  | INLET & PIPE PROTECTION                             |
|  | TEMPORARY PAVEMENT                                                                   |  | INLET & PIPE PROTECTION INSTALLED IN PREVIOUS STAGE |
|  | PERIMETER EROSION BARRIER (SEE NOTE 2)                                               |  | FLOW DIRECTION (SEE NOTE 4)                         |
|  | PERIMETER EROSION BARRIER INSTALLED IN PREVIOUS STAGE                                |  | PROPOSED STORM SEWER (SEE NOTE 1)                   |
|  | INLET FILTER                                                                         |  | PROPOSED STORM SEWER INSTALLED IN PREVIOUS STAGE    |
|  | INLET FILTER INSTALLED IN PREVIOUS STAGE                                             |  | TEMPORARY PIPE CULVERT                              |
|  | PERMANENT DRAINAGE STRUCTURE NUMBER (SEE NOTE 1)                                     |  |                                                     |

**NOTES**

- SEE PROPOSED DRAINAGE PLANS FOR STORM SEWER INFORMATION
- PERIMETER EROSION BARRIER SHALL BE ERECTED ADJACENT TO R.O.W., EASEMENT, AND CONSTRUCTION LIMITS AND AS DIRECTED BY THE ENGINEER.
- SEE LANDSCAPING PLANS FOR LANDSCAPING REQUIREMENTS.
- SEE STAGE 4 CROSS SECTIONS FOR GRADING INFORMATION.

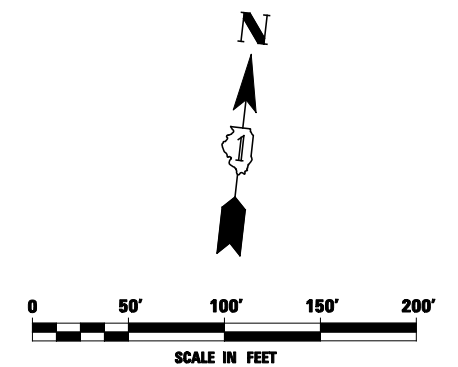

FILE NAME = #FILEL#	USER NAME = #USER#	DESIGNED <i>PJO</i>	REVISED -	<b>STATE OF ILLINOIS DEPARTMENT OF TRANSPORTATION</b>	<b>EROSION CONTROL - STAGE 4, 4A AND 4B RAMP A</b>	F.A.P. RTE.	SECTION	COUNTY	TOTAL SHEETS	SHEET NO.	
		DRAWN <i>KES</i>	REVISED -			338	(112 & 113) WRS-5	DUPAGE	963	533	
		CHECKED <i>JCM</i>	REVISED -			CONTRACT NO. 60I31					
		DATE <i>10/15/2012</i>	REVISED -			ILLINOIS FED. AID PROJECT					
				SCALE:	SHEET NO. 58 OF 66 SHEETS	STA. 1005+00 TO STA. 1019+00					

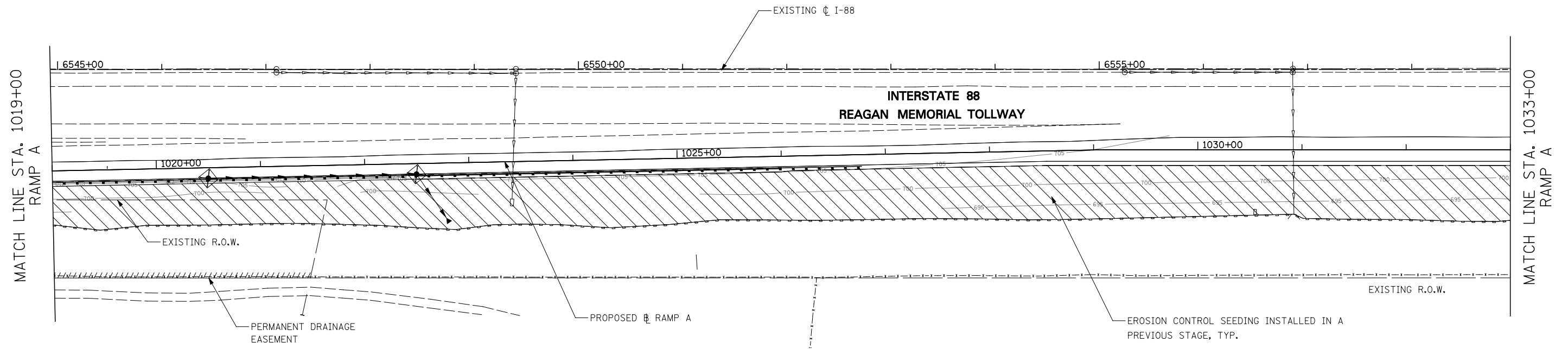

**EROSION CONTROL LEGEND**

	TEMPORARY EROSION CONTROL SEEDING AND TEMPORARY EROSION CONTROL BLANKET		TEMPORARY DITCH CHECK
	PERMANENT SEEDING (SEE NOTE 3)		TEMPORARY DITCH CHECK INSTALLED IN PREVIOUS STAGE
	TEMPORARY EROSION CONTROL SEEDING OR PERMANENT SEEDING INSTALLED IN A PREVIOUS STAGE		INLET & PIPE PROTECTION
	TEMPORARY PAVEMENT		INLET & PIPE PROTECTION INSTALLED IN PREVIOUS STAGE
	PERIMETER EROSION BARRIER (SEE NOTE 2)		FLOW DIRECTION (SEE NOTE 4)
	PERIMETER EROSION BARRIER INSTALLED IN PREVIOUS STAGE		PROPOSED STORM SEWER (SEE NOTE 1)
	INLET FILTER		PROPOSED STORM SEWER INSTALLED IN PREVIOUS STAGE
	INLET FILTER INSTALLED IN PREVIOUS STAGE		TEMPORARY PIPE CULVERT
	PERMANENT DRAINAGE STRUCTURE NUMBER (SEE NOTE 1)		

**NOTES**

1. SEE PROPOSED DRAINAGE PLANS FOR STORM SEWER INFORMATION
2. PERIMETER EROSION BARRIER SHALL BE ERECTED ADJACENT TO R.O.W., EASEMENT, AND CONSTRUCTION LIMITS AND AS DIRECTED BY THE ENGINEER.
3. SEE LANDSCAPING PLANS FOR LANDSCAPING REQUIREMENTS.
4. SEE STAGE 4 CROSS SECTIONS FOR GRADING INFORMATION.

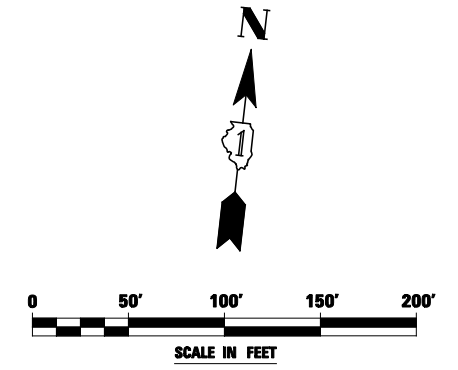

FILE NAME = #FILE#	USER NAME = #USER#	DESIGNED <i>PJO</i>	REVISED -	<b>STATE OF ILLINOIS DEPARTMENT OF TRANSPORTATION</b>	<b>EROSION CONTROL - STAGE 4, 4A, AND 4B RAMP A</b>	F.A.P. RTE.	SECTION	COUNTY	TOTAL SHEETS	SHEET NO.	
		DRAWN <i>KES</i>	REVISED -			338	(112 & 113) WRS-5	DUPAGE	963	534	
		CHECKED <i>JCM</i>	REVISED -			CONTRACT NO. 60I31					
		DATE <i>10/15/2012</i>	REVISED -			ILLINOIS FED. AID PROJECT					
				SCALE:	SHEET NO. 59 OF 66 SHEETS	STA. 1019+00	TO STA. 1033+00				

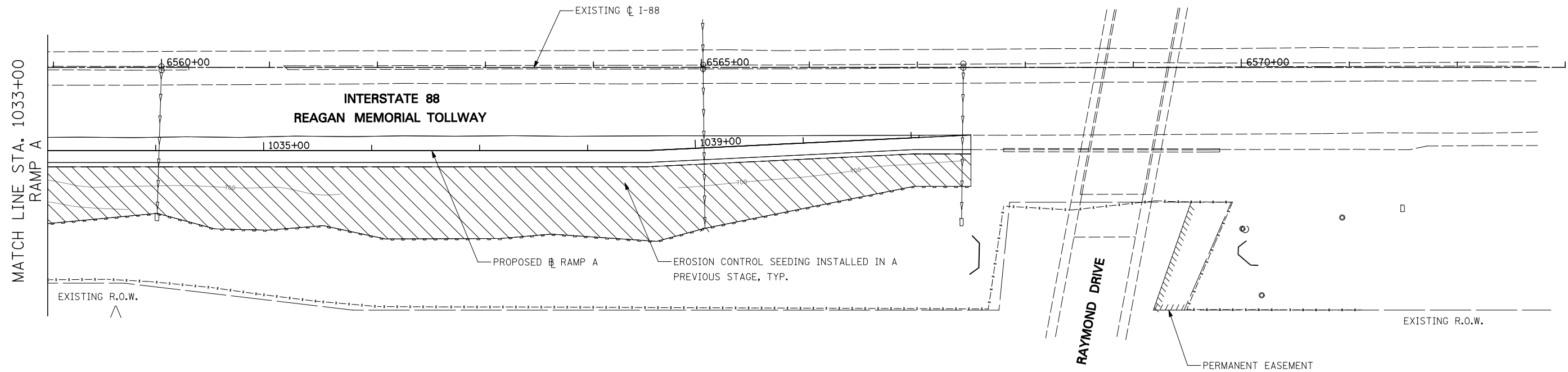

**EROSION CONTROL LEGEND**

	TEMPORARY EROSION CONTROL SEEDING AND TEMPORARY EROSION CONTROL BLANKET		TEMPORARY DITCH CHECK
	PERMANENT SEEDING (SEE NOTE 3)		TEMPORARY DITCH CHECK INSTALLED IN PREVIOUS STAGE
	TEMPORARY EROSION CONTROL SEEDING OR PERMANENT SEEDING INSTALLED IN A PREVIOUS STAGE		INLET & PIPE PROTECTION
	TEMPORARY PAVEMENT		INLET & PIPE PROTECTION INSTALLED IN PREVIOUS STAGE
	PERIMETER EROSION BARRIER (SEE NOTE 2)		FLOW DIRECTION (SEE NOTE 4)
	PERIMETER EROSION BARRIER INSTALLED IN PREVIOUS STAGE		PROPOSED STORM SEWER (SEE NOTE 1)
	INLET FILTER		PROPOSED STORM SEWER INSTALLED IN PREVIOUS STAGE
	INLET FILTER INSTALLED IN PREVIOUS STAGE		TEMPORARY PIPE CULVERT
	PERMANENT DRAINAGE STRUCTURE NUMBER (SEE NOTE 1)		

**NOTES**



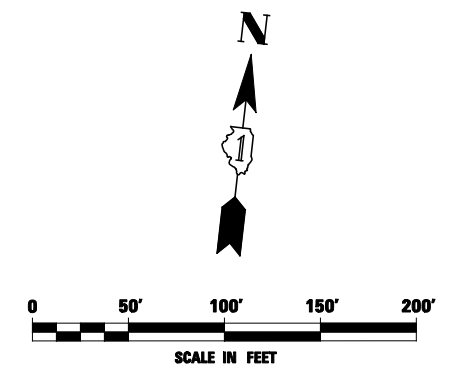



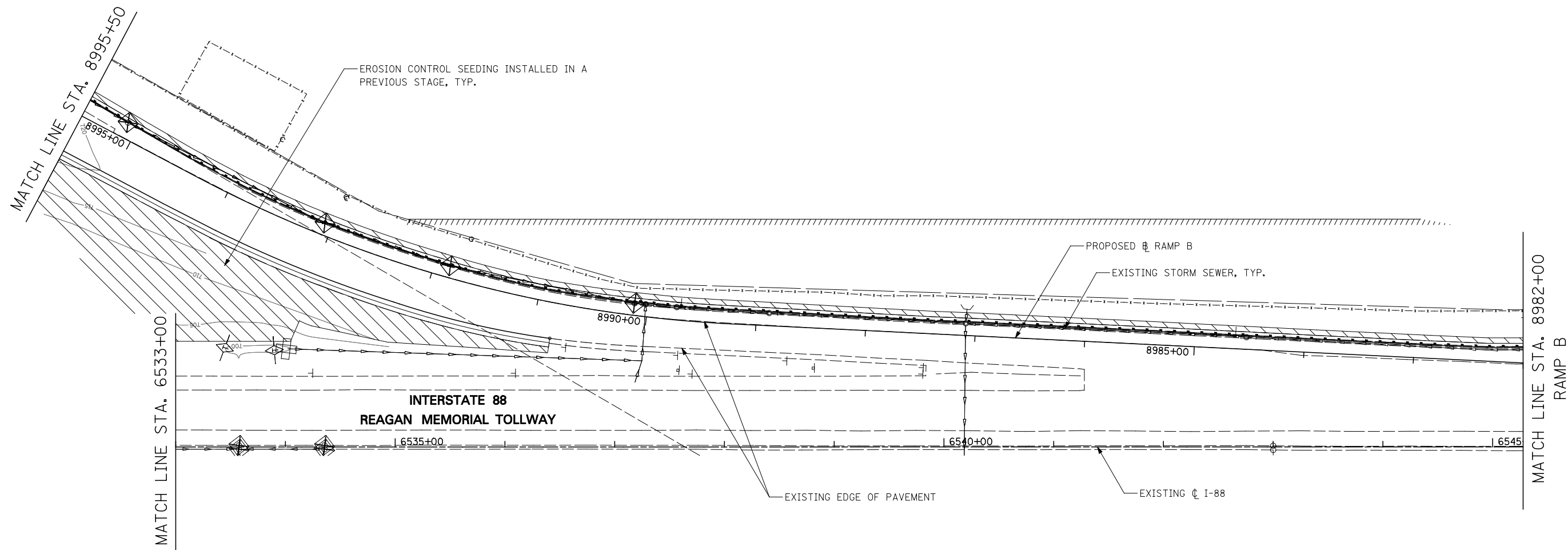





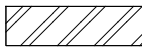



1. SEE PROPOSED DRAINAGE PLANS FOR STORM SEWER INFORMATION
2. PERIMETER EROSION BARRIER SHALL BE ERECTED ADJACENT TO R.O.W., EASEMENT, AND CONSTRUCTION LIMITS AND AS DIRECTED BY THE ENGINEER.
3. SEE LANDSCAPING PLANS FOR LANDSCAPING REQUIREMENTS.
4. SEE STAGE 4 CROSS SECTIONS FOR GRADING INFORMATION.

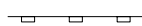

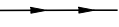
FILE NAME = #FILEL#	USER NAME = #USER#	DESIGNED <i>PJO</i>	REVISED -	<b>STATE OF ILLINOIS DEPARTMENT OF TRANSPORTATION</b>	<b>EROSION CONTROL - STAGE 4, 4A, AND 4B RAMP A</b>	F.A.P. RTE.	SECTION	COUNTY	TOTAL SHEETS	SHEET NO.	
		DRAWN <i>KES</i>	REVISED -			338	(112 & 113) WRS-5	DUPAGE	963	535	
		CHECKED <i>JCM</i>	REVISED -			CONTRACT NO. 60I31					
		DATE <i>10/15/2012</i>	REVISED -			ILLINOIS FED. AID PROJECT					
				SCALE:	SHEET NO. 60 OF 66 SHEETS	STA. 1033+00	TO STA. 1041+55				



**EROSION CONTROL LEGEND**

	TEMPORARY EROSION CONTROL SEEDING AND TEMPORARY EROSION CONTROL BLANKET		TEMPORARY DITCH CHECK
	PERMANENT SEEDING (SEE NOTE 3)		TEMPORARY DITCH CHECK INSTALLED IN PREVIOUS STAGE
	TEMPORARY EROSION CONTROL SEEDING OR PERMANENT SEEDING INSTALLED IN A PREVIOUS STAGE		INLET & PIPE PROTECTION
	TEMPORARY PAVEMENT		INLET & PIPE PROTECTION INSTALLED IN PREVIOUS STAGE
	PERIMETER EROSION BARRIER (SEE NOTE 2)		FLOW DIRECTION (SEE NOTE 4)
	PERIMETER EROSION BARRIER INSTALLED IN PREVIOUS STAGE		PROPOSED STORM SEWER (SEE NOTE 1)
	INLET FILTER		PROPOSED STORM SEWER INSTALLED IN PREVIOUS STAGE
	INLET FILTER INSTALLED IN PREVIOUS STAGE		TEMPORARY PIPE CULVERT
	PERMANENT DRAINAGE STRUCTURE NUMBER (SEE NOTE 1)		

**NOTES**

1. SEE PROPOSED DRAINAGE PLANS FOR STORM SEWER INFORMATION
2. PERIMETER EROSION BARRIER SHALL BE ERECTED ADJACENT TO R.O.W., EASEMENT, AND CONSTRUCTION LIMITS AND AS DIRECTED BY THE ENGINEER.
3. SEE LANDSCAPING PLANS FOR LANDSCAPING REQUIREMENTS.
4. SEE STAGE 4 CROSS SECTIONS FOR GRADING INFORMATION.

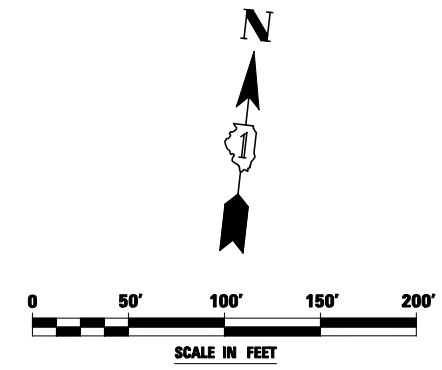

FILE NAME = #FILEL#	USER NAME = #USER#	DESIGNED <i>PJO</i>	REVISED -	<b>STATE OF ILLINOIS DEPARTMENT OF TRANSPORTATION</b>	<b>EROSION CONTROL - STAGE 4, 4A, AND 4B RAMP B</b>	F.A.P. RTE.	SECTION	COUNTY	TOTAL SHEETS	SHEET NO.	
		DRAWN <i>KES</i>	REVISED -			338	(112 & 113) WRS-5	DUPAGE	963	536	
		CHECKED <i>JCM</i>	REVISED -			CONTRACT NO. 60I31					
		DATE <i>10/15/2012</i>	REVISED -			SCALE:	SHEET NO. 61 OF 66 SHEETS	STA. 8982+00 TO STA. 8995+50	ILLINOIS FED. AID PROJECT		

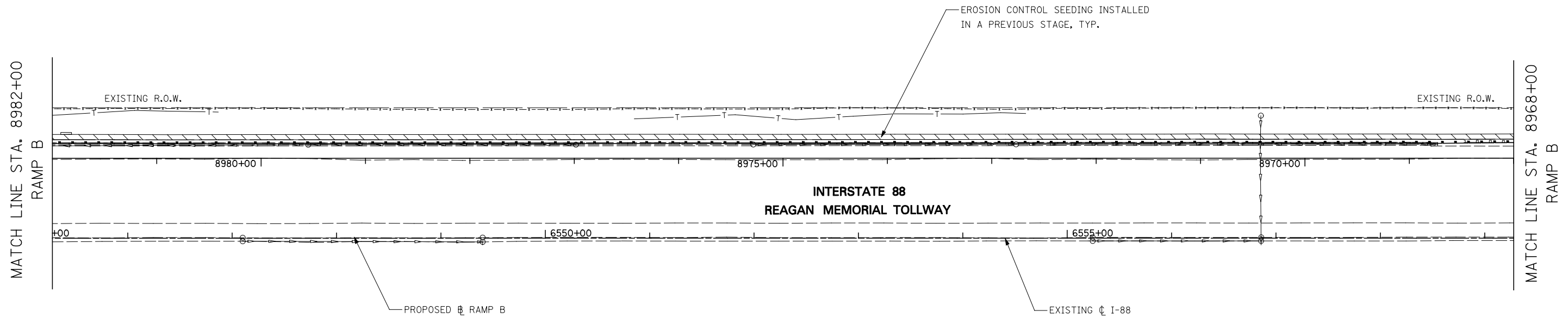

**EROSION CONTROL LEGEND**

	TEMPORARY EROSION CONTROL SEEDING AND TEMPORARY EROSION CONTROL BLANKET		TEMPORARY DITCH CHECK
	PERMANENT SEEDING (SEE NOTE 3)		TEMPORARY DITCH CHECK INSTALLED IN PREVIOUS STAGE
	TEMPORARY EROSION CONTROL SEEDING OR PERMANENT SEEDING INSTALLED IN A PREVIOUS STAGE		INLET & PIPE PROTECTION
	TEMPORARY PAVEMENT		INLET & PIPE PROTECTION INSTALLED IN PREVIOUS STAGE
	PERIMETER EROSION BARRIER (SEE NOTE 2)		FLOW DIRECTION (SEE NOTE 4)
	PERIMETER EROSION BARRIER INSTALLED IN PREVIOUS STAGE		PROPOSED STORM SEWER (SEE NOTE 1)
	INLET FILTER		PROPOSED STORM SEWER INSTALLED IN PREVIOUS STAGE
	INLET FILTER INSTALLED IN PREVIOUS STAGE		TEMPORARY PIPE CULVERT
	PERMANENT DRAINAGE STRUCTURE NUMBER (SEE NOTE 1)		

**NOTES**

1. SEE PROPOSED DRAINAGE PLANS FOR STORM SEWER INFORMATION
2. PERIMETER EROSION BARRIER SHALL BE ERECTED ADJACENT TO R.O.W., EASEMENT, AND CONSTRUCTION LIMITS AND AS DIRECTED BY THE ENGINEER.
3. SEE LANDSCAPING PLANS FOR LANDSCAPING REQUIREMENTS.
4. SEE STAGE 4 CROSS SECTIONS FOR GRADING INFORMATION.

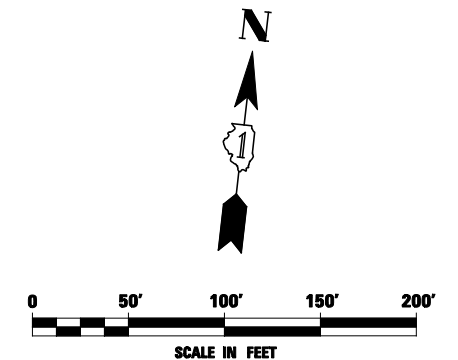

FILE NAME = #FILEL#	USER NAME = #USER#	DESIGNED <i>PJO</i>	REVISED -	<b>STATE OF ILLINOIS DEPARTMENT OF TRANSPORTATION</b>	<b>EROSION CONTROL - STAGE 4, 4A, AND 4B RAMP B</b>	F.A.P. RTE.	SECTION	COUNTY	TOTAL SHEETS	SHEET NO.	
		DRAWN <i>KES</i>	REVISED -			338	(112 & 113) WRS-5	DUPAGE	963	537	
		CHECKED <i>JCM</i>	REVISED -			CONTRACT NO. 60I31					
		DATE <i>10/15/2012</i>	REVISED -			ILLINOIS FED. AID PROJECT					
				SCALE:		SHEET NO. 62 OF 66 SHEETS		STA. 8968+00 TO STA. 8982+00			

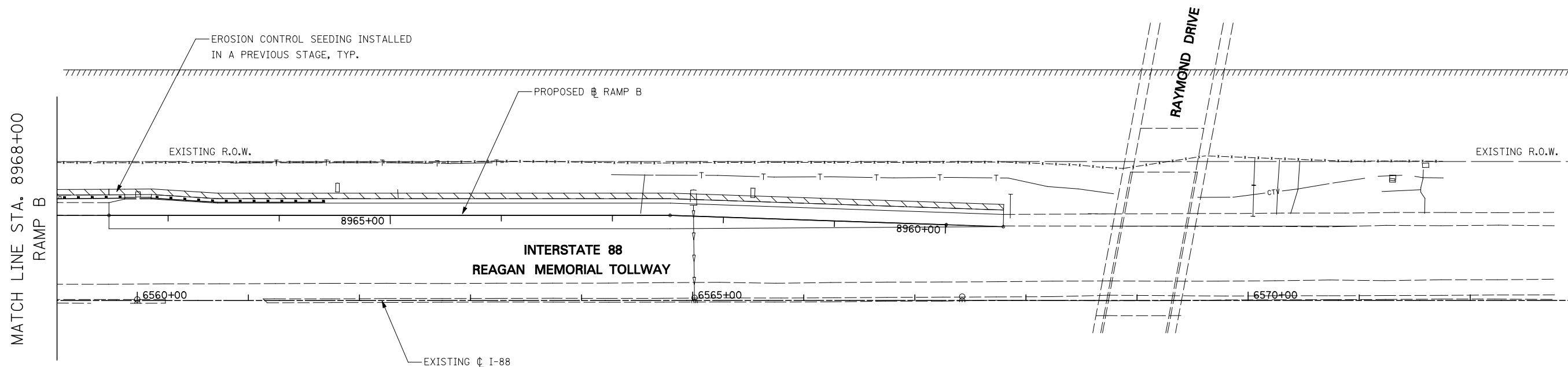

**EROSION CONTROL LEGEND**

	TEMPORARY EROSION CONTROL SEEDING AND TEMPORARY EROSION CONTROL BLANKET		TEMPORARY DITCH CHECK
	PERMANENT SEEDING (SEE NOTE 3)		TEMPORARY DITCH CHECK INSTALLED IN PREVIOUS STAGE
	TEMPORARY EROSION CONTROL SEEDING OR PERMANENT SEEDING INSTALLED IN A PREVIOUS STAGE		INLET & PIPE PROTECTION
	TEMPORARY PAVEMENT		INLET & PIPE PROTECTION INSTALLED IN PREVIOUS STAGE
	PERIMETER EROSION BARRIER (SEE NOTE 2)		FLOW DIRECTION (SEE NOTE 4)
	PERIMETER EROSION BARRIER INSTALLED IN PREVIOUS STAGE		PROPOSED STORM SEWER (SEE NOTE 1)
	INLET FILTER		PROPOSED STORM SEWER INSTALLED IN PREVIOUS STAGE
	INLET FILTER INSTALLED IN PREVIOUS STAGE		TEMPORARY PIPE CULVERT
	PERMANENT DRAINAGE STRUCTURE NUMBER (SEE NOTE 1)		

**NOTES**

1. SEE PROPOSED DRAINAGE PLANS FOR STORM SEWER INFORMATION
2. PERIMETER EROSION BARRIER SHALL BE ERECTED ADJACENT TO R.O.W., EASEMENT, AND CONSTRUCTION LIMITS AND AS DIRECTED BY THE ENGINEER.
3. SEE LANDSCAPING PLANS FOR LANDSCAPING REQUIREMENTS.
4. SEE STAGE 4 CROSS SECTIONS FOR GRADING INFORMATION.

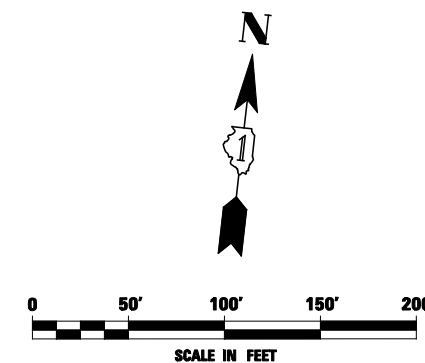

FILE NAME = #FILE#	USER NAME = #USER#	DESIGNED <i>PJO</i>	REVISED -	<b>STATE OF ILLINOIS DEPARTMENT OF TRANSPORTATION</b>	<b>EROSION CONTROL - STAGE 4, 4A, AND 4B RAMP B</b>	F.A.P. RTE.	SECTION	COUNTY	TOTAL SHEETS	SHEET NO.	
		DRAWN <i>KES</i>	REVISED -			338	(112 & 113) WRS-5	DUPAGE	963	538	
		CHECKED <i>JCM</i>	REVISED -			CONTRACT NO. 60I31					
		DATE <i>10/15/2012</i>	REVISED -			SCALE:	SHEET NO. 63 OF 66 SHEETS	STA. 8959+48	TO STA. 8968+00	ILLINOIS FED. AID PROJECT	

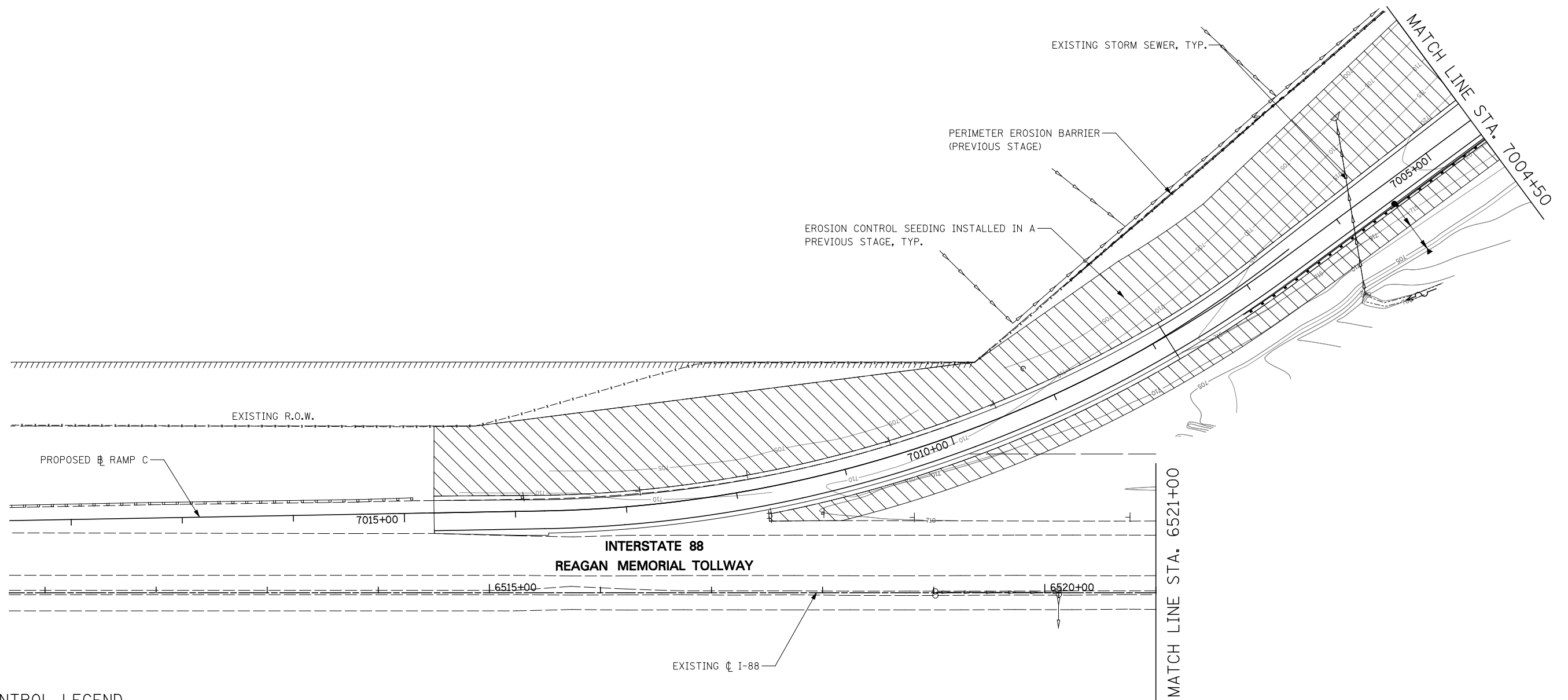

**EROSION CONTROL LEGEND**

	TEMPORARY EROSION CONTROL SEEDING AND TEMPORARY EROSION CONTROL BLANKET		TEMPORARY DITCH CHECK
	PERMANENT SEEDING (SEE NOTE 3)		TEMPORARY DITCH CHECK INSTALLED IN PREVIOUS STAGE
	TEMPORARY EROSION CONTROL SEEDING OR PERMANENT SEEDING INSTALLED IN A PREVIOUS STAGE		INLET & PIPE PROTECTION
	TEMPORARY PAVEMENT		INLET & PIPE PROTECTION INSTALLED IN PREVIOUS STAGE
	PERIMETER EROSION BARRIER (SEE NOTE 2)		FLOW DIRECTION (SEE NOTE 4)
	PERIMETER EROSION BARRIER INSTALLED IN PREVIOUS STAGE		PROPOSED STORM SEWER (SEE NOTE 1)
	INLET FILTER		PROPOSED STORM SEWER INSTALLED IN PREVIOUS STAGE
	INLET FILTER INSTALLED IN PREVIOUS STAGE		TEMPORARY PIPE CULVERT
	PERMANENT DRAINAGE STRUCTURE NUMBER (SEE NOTE 1)		

**NOTES**

1. SEE PROPOSED DRAINAGE PLANS FOR STORM SEWER INFORMATION
2. PERIMETER EROSION BARRIER SHALL BE ERECTED ADJACENT TO R.O.W., EASEMENT, AND CONSTRUCTION LIMITS AND AS DIRECTED BY THE ENGINEER.
3. SEE LANDSCAPING PLANS FOR LANDSCAPING REQUIREMENTS.
4. SEE STAGE 4 CROSS SECTIONS FOR GRADING INFORMATION.

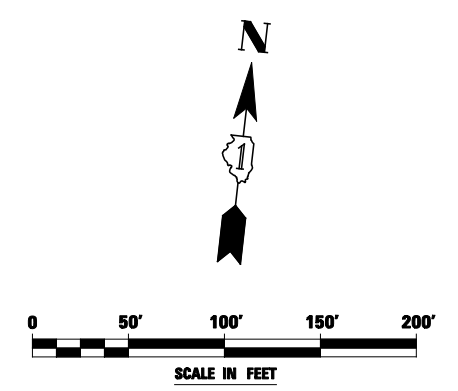

FILE NAME = #FILEL#	USER NAME = #USER#	DESIGNED <i>PJO</i>	REVISED -	<b>STATE OF ILLINOIS DEPARTMENT OF TRANSPORTATION</b>	<b>EROSION CONTROL - STAGE 4, 4A AND 4B RAMP C</b>		F.A.P. RTE.	SECTION	COUNTY	TOTAL SHEETS	SHEET NO.	
		DRAWN <i>KES</i>	REVISED -		SCALE:	SHEET NO. 64 OF 66 SHEETS	STA. 7004+50 TO STA. 7018+55	338	(112 & 113) WRS-5	DUPAGE	963	539
		CHECKED <i>JCM</i>	REVISED -					CONTRACT NO. 60I31				
		DATE <i>10/15/2012</i>	REVISED -		ILLINOIS FED. AID PROJECT							

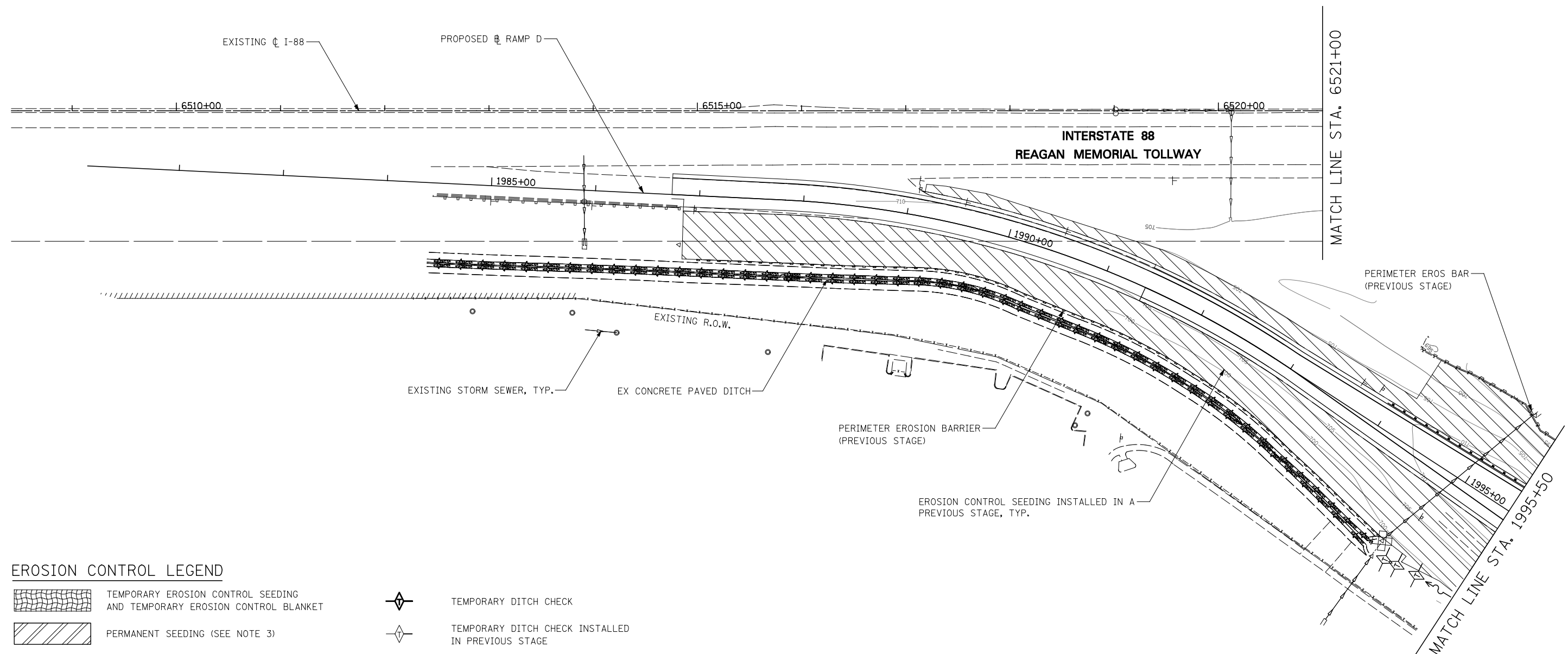

**EROSION CONTROL LEGEND**

	TEMPORARY EROSION CONTROL SEEDING AND TEMPORARY EROSION CONTROL BLANKET		TEMPORARY DITCH CHECK
	PERMANENT SEEDING (SEE NOTE 3)		TEMPORARY DITCH CHECK INSTALLED IN PREVIOUS STAGE
	TEMPORARY EROSION CONTROL SEEDING OR PERMANENT SEEDING INSTALLED IN A PREVIOUS STAGE		INLET & PIPE PROTECTION
	TEMPORARY PAVEMENT		INLET & PIPE PROTECTION INSTALLED IN PREVIOUS STAGE
	PERIMETER EROSION BARRIER (SEE NOTE 2)		FLOW DIRECTION (SEE NOTE 4)
	PERIMETER EROSION BARRIER INSTALLED IN PREVIOUS STAGE		PROPOSED STORM SEWER (SEE NOTE 1)
	INLET FILTER		PROPOSED STORM SEWER INSTALLED IN PREVIOUS STAGE
	INLET FILTER INSTALLED IN PREVIOUS STAGE		TEMPORARY PIPE CULVERT
	PERMANENT DRAINAGE STRUCTURE NUMBER (SEE NOTE 1)		

**NOTES**

- SEE PROPOSED DRAINAGE PLANS FOR STORM SEWER INFORMATION
- PERIMETER EROSION BARRIER SHALL BE ERECTED ADJACENT TO R.O.W., EASEMENT, AND CONSTRUCTION LIMITS AND AS DIRECTED BY THE ENGINEER.
- SEE LANDSCAPING PLANS FOR LANDSCAPING REQUIREMENTS.
- SEE STAGE 4 CROSS SECTIONS FOR GRADING INFORMATION.

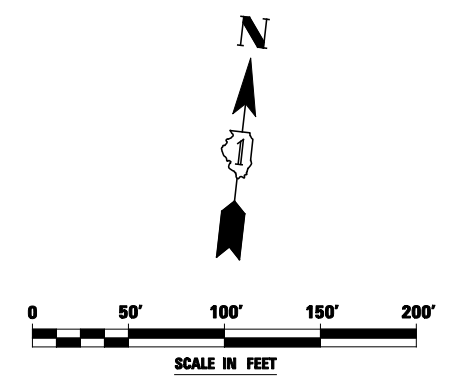

FILE NAME = #FILEL#	USER NAME = #USER#	DESIGNED <i>PJO</i>	REVISED -	<b>STATE OF ILLINOIS DEPARTMENT OF TRANSPORTATION</b>	<b>EROSION CONTROL - STAGE 4, 4A AND 4B RAMP D</b>		F.A.P. RTE. 338	SECTION (112 & 113) WRS-5	COUNTY DUPAGE	TOTAL SHEETS 963	SHEET NO. 540	
	PLOT SCALE = #SCALE#	DRAWN <i>KES</i>	REVISED -		SCALE:	SHEET NO. 65 OF 66 SHEETS	STA. 1981+22 TO STA. 1995+50	CONTRACT NO. 60I31		ILLINOIS FED. AID PROJECT		
	PLOT DATE = #DATE#	CHECKED <i>JCM</i>	REVISED -									
		DATE <i>10/15/2012</i>	REVISED -									



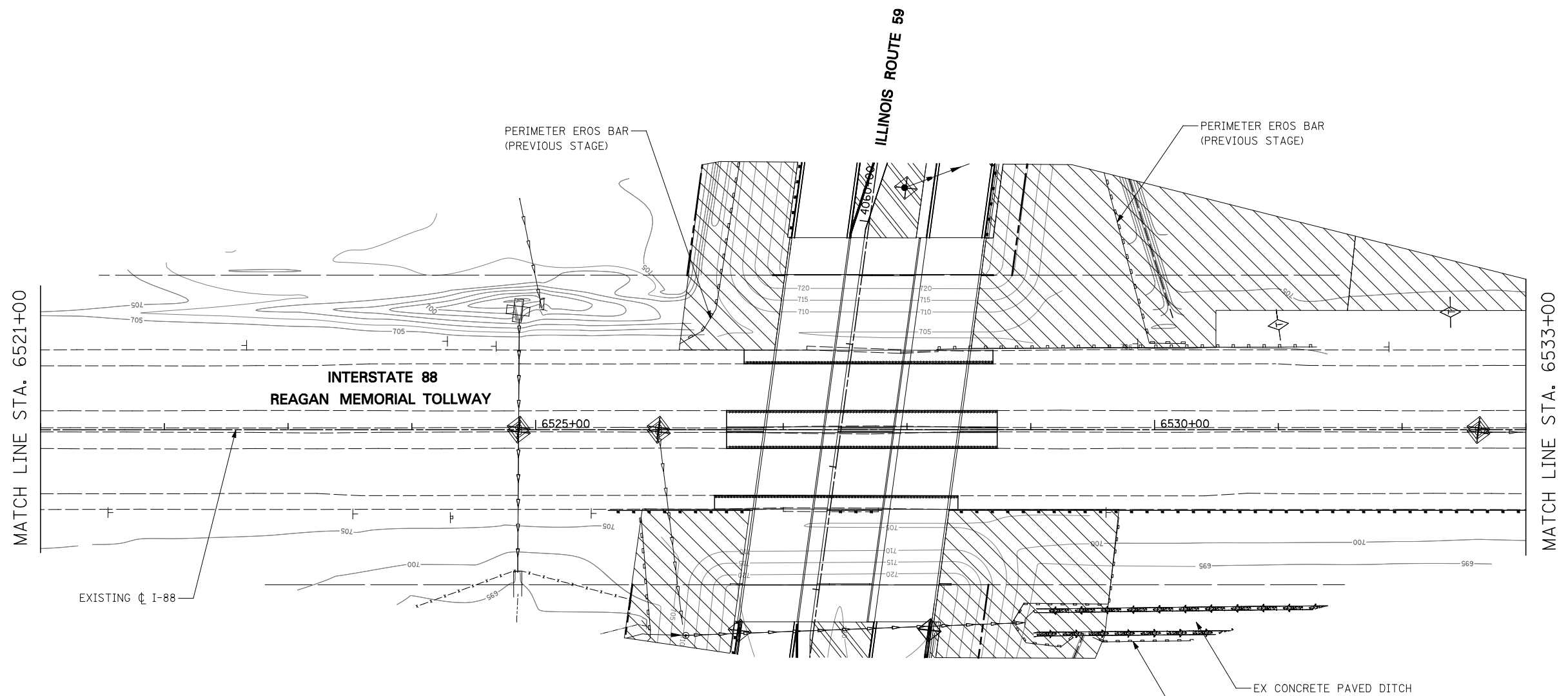

**EROSION CONTROL LEGEND**

- |  |                                                                                      |  |                                                     |
|--|--------------------------------------------------------------------------------------|--|-----------------------------------------------------|
|  | TEMPORARY EROSION CONTROL SEEDING AND TEMPORARY EROSION CONTROL BLANKET              |  | TEMPORARY DITCH CHECK                               |
|  | PERMANENT SEEDING (SEE NOTE 3)                                                       |  | TEMPORARY DITCH CHECK INSTALLED IN PREVIOUS STAGE   |
|  | TEMPORARY EROSION CONTROL SEEDING OR PERMANENT SEEDING INSTALLED IN A PREVIOUS STAGE |  | INLET & PIPE PROTECTION                             |
|  | TEMPORARY PAVEMENT                                                                   |  | INLET & PIPE PROTECTION INSTALLED IN PREVIOUS STAGE |
|  | PERIMETER EROSION BARRIER (SEE NOTE 2)                                               |  | FLOW DIRECTION (SEE NOTE 4)                         |
|  | PERIMETER EROSION BARRIER INSTALLED IN PREVIOUS STAGE                                |  | PROPOSED STORM SEWER (SEE NOTE 1)                   |
|  | INLET FILTER                                                                         |  | PROPOSED STORM SEWER INSTALLED IN PREVIOUS STAGE    |
|  | INLET FILTER INSTALLED IN PREVIOUS STAGE                                             |  | TEMPORARY PIPE CULVERT                              |
|  | PERMANENT DRAINAGE STRUCTURE NUMBER (SEE NOTE 1)                                     |  |                                                     |

**NOTES**

- SEE PROPOSED DRAINAGE PLANS FOR STORM SEWER INFORMATION
- PERIMETER EROSION BARRIER SHALL BE ERECTED ADJACENT TO R.O.W., EASEMENT, AND CONSTRUCTION LIMITS AND AS DIRECTED BY THE ENGINEER.
- SEE LANDSCAPING PLANS FOR LANDSCAPING REQUIREMENTS.
- SEE STAGE 4 CROSS SECTIONS FOR GRADING INFORMATION.

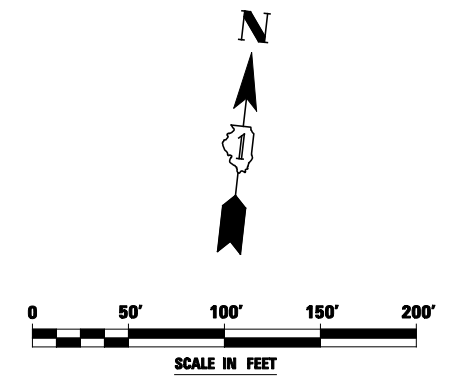

FILE NAME = #FILEL#	USER NAME = #USER#	DESIGNED <i>PJO</i>	REVISED -
		DRAWN <i>KES</i>	REVISED -
		CHECKED <i>JCM</i>	REVISED -
		DATE <i>10/15/2012</i>	REVISED -

**STATE OF ILLINOIS  
DEPARTMENT OF TRANSPORTATION**

**EROSION CONTROL STAGE 4, 4A, AND 4B  
INTERSTATE 88**

SCALE: SHEET NO. 66 OF 66 SHEETS STA. 6521+00 TO STA. 6533+00

F.A.P. RTE.	SECTION	COUNTY	TOTAL SHEETS	SHEET NO.
338	(112 & 113) WRS-5	DUPAGE	963	541
CONTRACT NO. 60I31				
ILLINOIS FED. AID PROJECT				

## IL 59 LANDSCAPE SCHEDULE - 60I31

BOTANICAL NAME	COMMON NAME	SIZE	UNIT OF MEASURE	TOTAL	PLAN SHEET NUMBER											
					1	2	3	4	5	6	7	8	9	10	11	12
<b>SHADE TREES</b>																
CELTIS OCCIDENTALIS	COMMON HACKBERRY	2" CAL / B&B	EACH	6				6								
GYMNOCLAUS DIOICUS	KENTUCKY COFFEETREE	2-1/2" CAL / B&B	EACH	22				22								
GYMNOCLAUS DIOICUS	KENTUCKY COFFEETREE	8' HT / B&B	EACH	15	8	7										
NYSSA SYLVATICA	BLACK TUPELO	2" CAL / B&B	EACH	5	5											
QUERCUS BICOLOR	SWAMP WHITE OAK	2" CAL / B&B	EACH	6	6											
QUERCUS MACROCARPA	BUR OAK	2" CAL / B&B	EACH	5				5								
QUERCUS MUEHLENBERGII	CHINKAPIN OAK	2" CAL / B&B	EACH	8				6	2							
TILIA AMERICANA	AMERICAN LINDEN	2" CAL / B&B	EACH	6				6								
ULMUS AMERICANA 'PRINCETON'	PRINCETON AMERICAN ELM	2" CAL / B&B	EACH	6				6								
<b>ORNAMENTAL TREES</b>																
CRATAEGUS CRUSGALLI INERMIS	THORNLESS COCKSPUR HAWTHORN	2" CAL / B&B	EACH	7	7											
CRATAEGUS CRUSGALLI INERMIS	THORNLESS COCKSPUR HAWTHORN	6' HT / B&B	EACH	15	6	9										
MALUS 'DONALD WYMAN'	DONALD WYMAN CRABAPPLE	2" CAL / B&B	EACH	10				10								
MALUS 'INDIAN SUMMER'	INDIAN SUMMER CRABAPPLE	6' HT / B&B	EACH	7	7											
SYRINGA PEKINENSIS 'CHINA SNOW'	CHINA SNOW PEKING LILAC	2" CAL / B&B	EACH	11				11								
SYRINGA PEKINENSIS 'ZHING ZHIMING'	BEIJING GOLD PEKING LILAC	2" CAL / B&B	EACH	13	13											
<b>EVERGREEN TREES</b>																
PINUS NIGRA	AUSTRIAN PINE	7' HT / B&B	EACH	4	4											
<b>VINES</b>																
PARTHENOCISSUS QUINQUEFOLIA 'ENGELMANNII'	ENGELMANNII VIRGINIA CREEPER	1 - GAL CONT	EACH	240	43	154	43									
<b>TOLLWAY</b>																
GLEDITSIA TRIACANTHOS INERMIS SKYLINE	SKYLINE THORNLESS COMMON HONEYLOCUST	2" CAL / B&B	EACH	12		12										
<b>LAWN</b>																
SODDING, SALT TOLERANT		N/A	SQ YD	22,534	4,031	8,762	9,551	190								
SEEDING, CLASS 2A		N/A	ACRE	0.50			0.39	0.11								
<b>TOLLWAY SEEDING</b>																
SEEDING, CLASS 2E		N/A	ACRE	4.25		0.81		0.33	0.23	1.08	0.11	0.17	0.29	0.71	0.52	
SEEDING, CLASS 3E		N/A	ACRE	10.00		5.42		1.19	1.29				0.23	1.18	0.69	
SEEDING, CLASS 4B		N/A	ACRE	0.50		0.46									0.04	
SEEDING, CLASS 4F		N/A	ACRE	1.50		0.99								0.51		

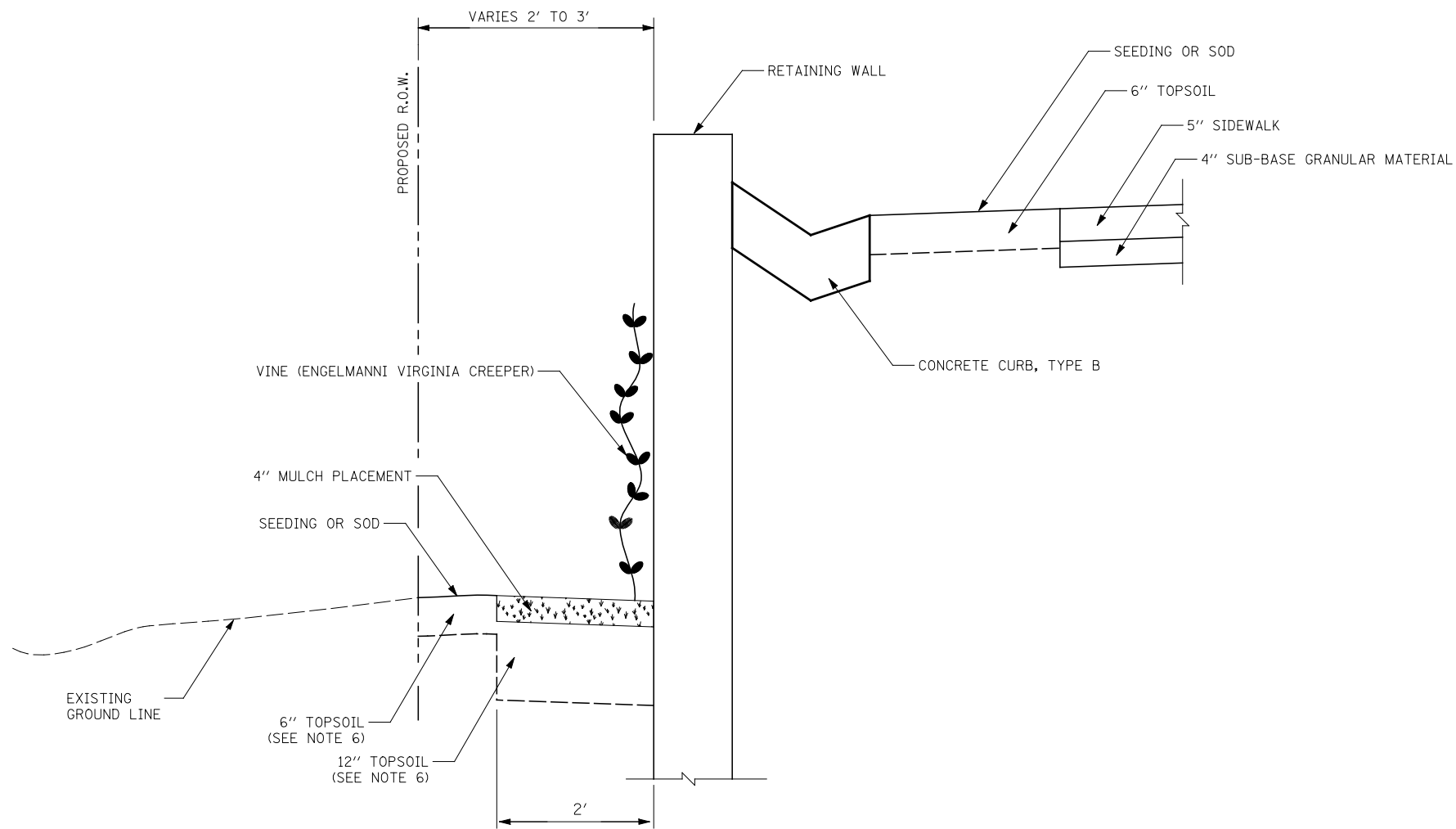

LANDSCAPE DETAIL AT  
RETAINING WALLS 022-W064 & 022-W066

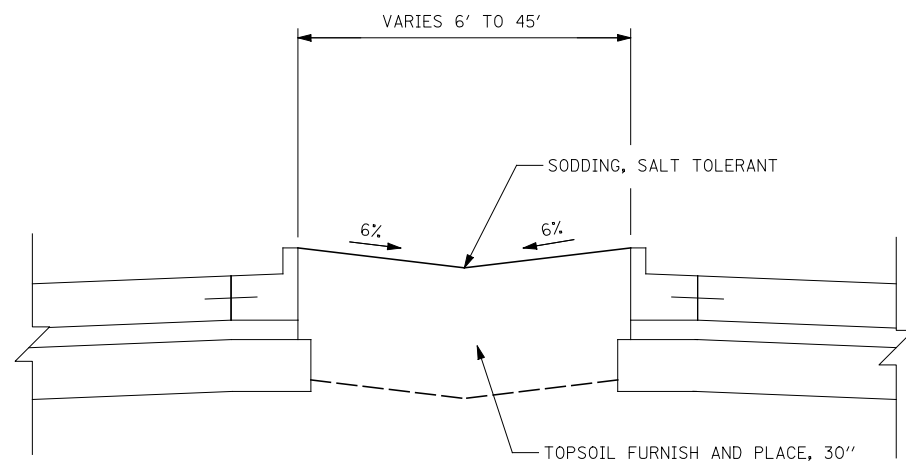

TYPICAL LANDSCAPED MEDIAN DETAIL

GENERAL LANDSCAPING NOTES:

1. WEED CONTROL, PRE-EMERGENT GRANULAR HERBICIDE SHALL BE USED FOR ALL NEWLY INSTALLED PLANT MATERIAL, INCLUDING: TREES, SHRUBS, AND VINES.
2. THE USE OF PHOSPHOROUS FERTILIZER NUTRIENTS SHALL BE OMITTED AS SPECIFIED IN SECTIONS 250 AND 252 OF THE STANDARD SPECIFICATIONS FOR SEEDING, CLASS 2A AND SODDING, SALT TOLERANT AREAS.
3. THE ENGINEER WILL CONTACT FABIOLA QUIROZ OF THE ROADSIDE DEVELOPMENT UNIT AT (847) 705-4596, AT LEAST 7 DAYS PRIOR TO PLANTING FOR LAYOUT APPROVAL OF THE SEEDING, SODDING, TREES, SHRUBS, AND VINES.
4. ALL EXISTING DRIVEWAY AND/OR ROADWAY PAVEMENT THAT IS TO BE REMOVED AND REPLACED WITH LANDSCAPING SHALL BE EXCAVATED TO ALLOW FOR THE PLACEMENT OF 30" OF TOPSOIL. THIS WORK SHALL BE PAID FOR AS TOPSOIL EXCAVATION AND PLACEMENT. ANY ADDITIONAL EXCAVATION REQUIRED FOR THE PLACEMENT OF THE 30" OF TOPSOIL SHALL BE CONSIDERED INCLUDED IN THE CONTRACT UNIT PRICE FOR TOPSOIL EXCAVATION AND PLACEMENT.
5. THE COST OF FURNISHING AND PLACING THE MULCH ALONG THE RETAINING WALL IS INCIDENTAL TO THE PLANTINGS BEING INSTALLED.
6. TOPSOIL SHALL BE PAID FOR AS TOPSOIL EXCAVATION AND PLACEMENT.

FILE NAME =	USER NAME = #USER#	DESIGNED <i>PJO</i>	REVISED -
#FILE#		DRAWN <i>KES</i>	REVISED -
	PLOT SCALE = #SCALE#	CHECKED <i>JCM</i>	REVISED -
	PLOT DATE = #DATE#	DATE <i>10/15/2012</i>	REVISED -

**STATE OF ILLINOIS  
DEPARTMENT OF TRANSPORTATION**



**LANDSCAPE GENERAL NOTES AND DETAILS**

SCALE: SHEET NO. 1 OF 1 SHEETS STA. TO STA.

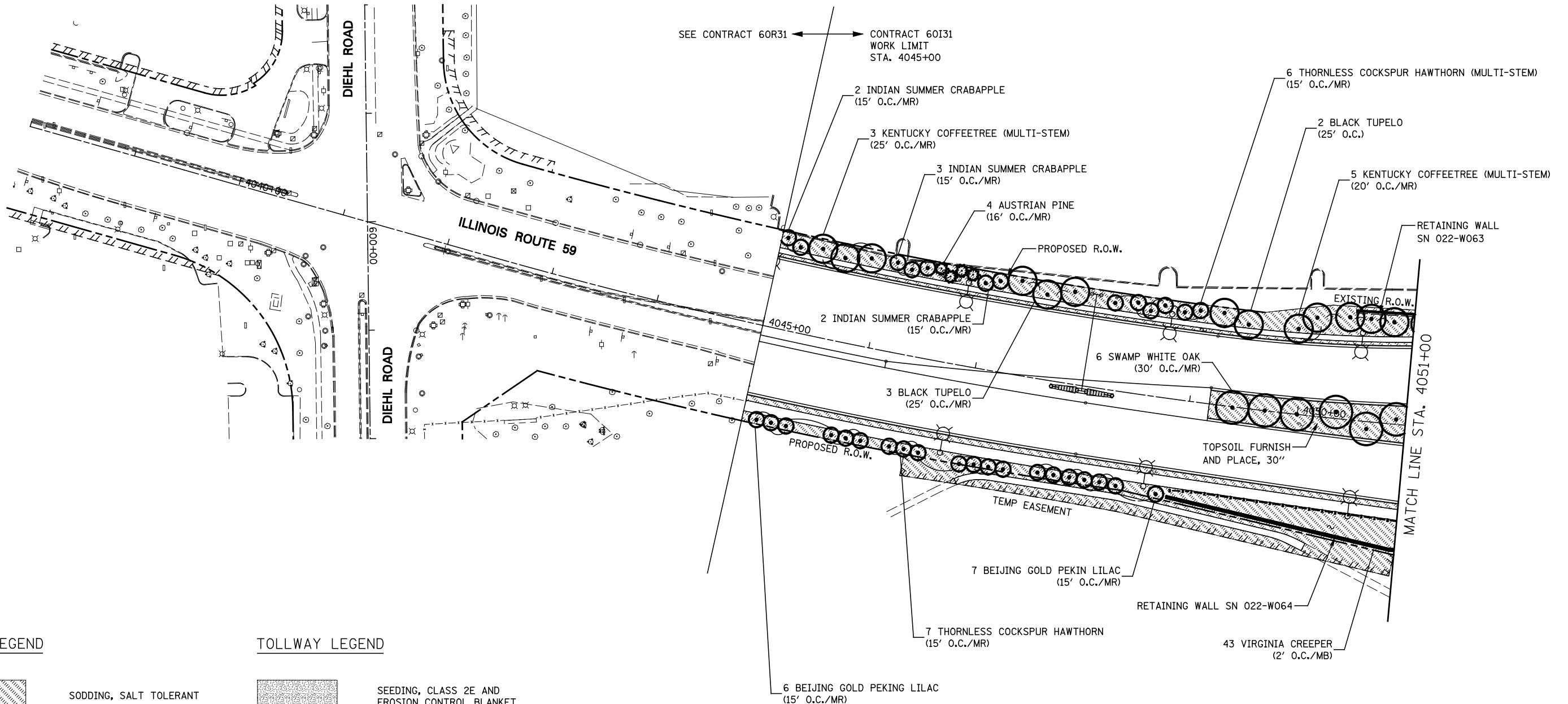

F.A.P. RTE.	SECTION	COUNTY	TOTAL SHEETS	SHEET NO.
338	(112 & 113) WRS-5	DUPAGE	963	543
CONTRACT NO. 60I31				
ILLINOIS FED. AID PROJECT				



**IDOT LEGEND**

-  SODDING, SALT TOLERANT
-  SEEDING, CLASS 2A AND EROSION CONTROL BLANKET

**TOLLWAY LEGEND**

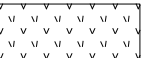
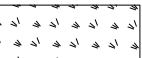
-  SEEDING, CLASS 2E AND EROSION CONTROL BLANKET
-  SEEDING, CLASS 3E AND EROSION CONTROL BLANKET
-  SEEDING, CLASS 4B AND EROSION CONTROL BLANKET
-  SEEDING, CLASS 4F AND EROSION CONTROL BLANKET

**NOTES:**

1. 6" OF TOPSOIL SHALL BE PLACED IN ALL LANDSCAPED AREAS, UNLESS OTHERWISE NOTED ON THE PLANS. THIS WORK SHALL BE PAID FOR AS TOPSOIL EXCAVATION AND PLACEMENT.

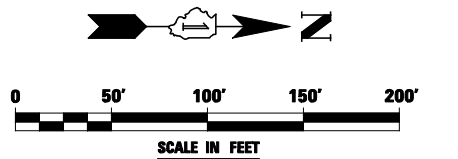

FILE NAME = #FILEL#	USER NAME = #USER#	DESIGNED <i>PJO</i>	REVISED -
		DRAWN <i>KES</i>	REVISED -
		CHECKED <i>JCM</i>	REVISED -
		DATE <i>10/15/2012</i>	REVISED -

**STATE OF ILLINOIS  
DEPARTMENT OF TRANSPORTATION**

**LANDSCAPE PLANS  
ILLINOIS ROUTE 59**

SCALE: SHEET NO. 1 OF 12 SHEETS STA. 4045+00 TO STA. 4051+00

F.A.P. RTE.	SECTION	COUNTY	TOTAL SHEETS	SHEET NO.
338	(112 & 113) WRS-5	DUPAGE	963	544
CONTRACT NO. 60I31				
ILLINOIS FED. AID PROJECT				

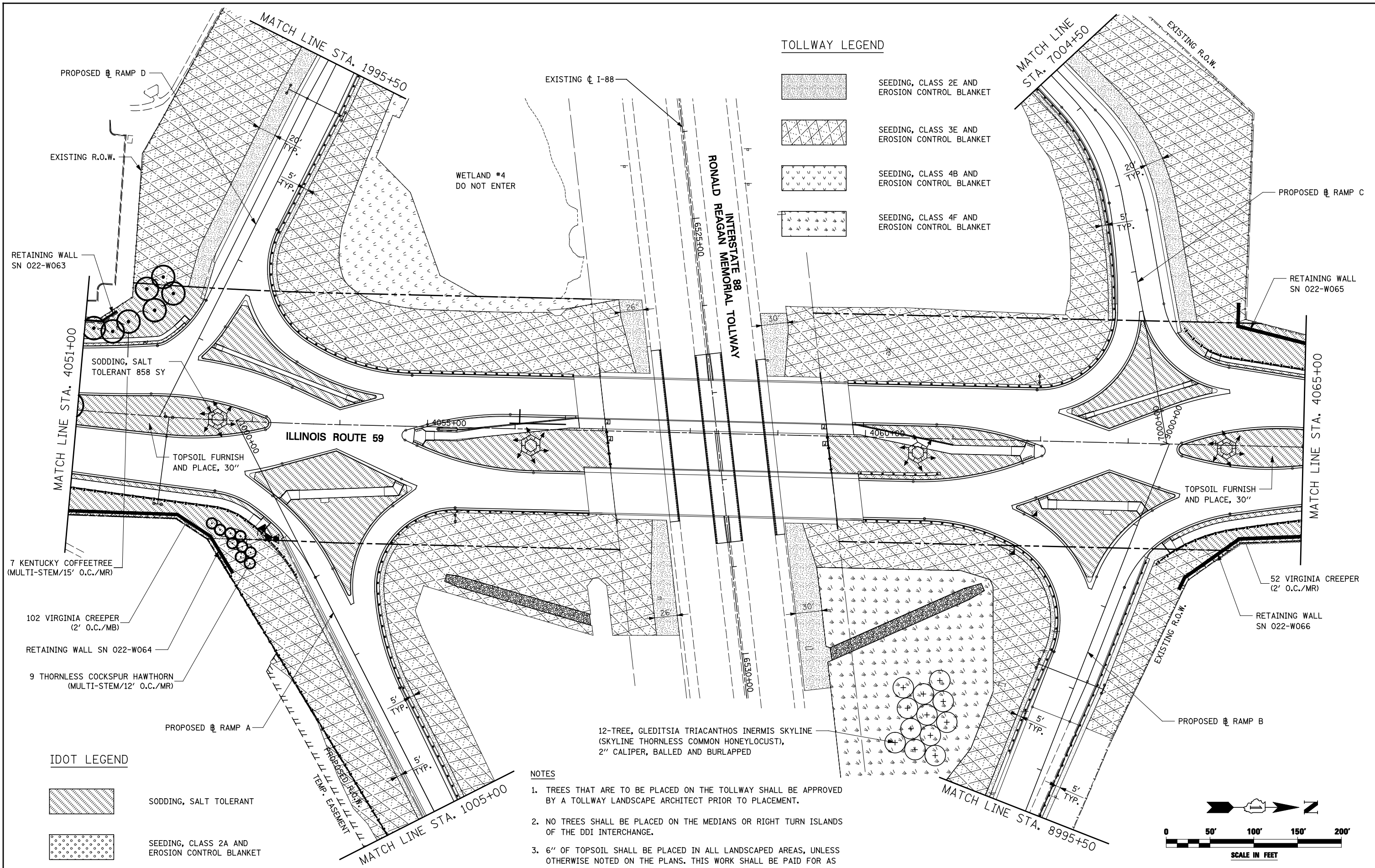

**TOLLWAY LEGEND**

[Stippled pattern]	SEEDING, CLASS 2E AND EROSION CONTROL BLANKET
[Cross-hatched pattern]	SEEDING, CLASS 3E AND EROSION CONTROL BLANKET
[V-shaped pattern]	SEEDING, CLASS 4B AND EROSION CONTROL BLANKET
[Arrow pattern]	SEEDING, CLASS 4F AND EROSION CONTROL BLANKET

**IDOT LEGEND**

[Stippled pattern]	SODDING, SALT TOLERANT
[Dotted pattern]	SEEDING, CLASS 2A AND EROSION CONTROL BLANKET

- NOTES**
1. TREES THAT ARE TO BE PLACED ON THE TOLLWAY SHALL BE APPROVED BY A TOLLWAY LANDSCAPE ARCHITECT PRIOR TO PLACEMENT.
  2. NO TREES SHALL BE PLACED ON THE MEDIANS OR RIGHT TURN ISLANDS OF THE DDI INTERCHANGE.
  3. 6" OF TOPSOIL SHALL BE PLACED IN ALL LANDSCAPED AREAS, UNLESS OTHERWISE NOTED ON THE PLANS. THIS WORK SHALL BE PAID FOR AS TOPSOIL EXCAVATION AND PLACEMENT.

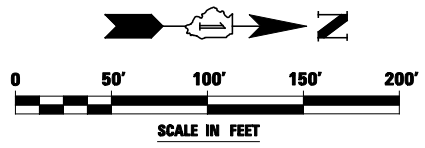

FILE NAME = #FILE#	USER NAME = #USER#	DESIGNED <i>PJO</i>	REVISED -	<b>STATE OF ILLINOIS DEPARTMENT OF TRANSPORTATION</b>	<b>LANDSCAPE PLANS ILLINOIS ROUTE 59</b>	F.A.P. RTE.	SECTION	COUNTY	TOTAL SHEETS	SHEET NO.	
		DRAWN <i>KES</i>	REVISED -			338	(112 & 113) WRS-5	DUPAGE	963	545	
		CHECKED <i>JCM</i>	REVISED -			CONTRACT NO. 60131					
		DATE <i>10/15/2012</i>	REVISED -			ILLINOIS FED. AID PROJECT					
				SCALE:	SHEET NO. 2 OF 12 SHEETS	STA. 4051+00 TO STA. 4065+00					

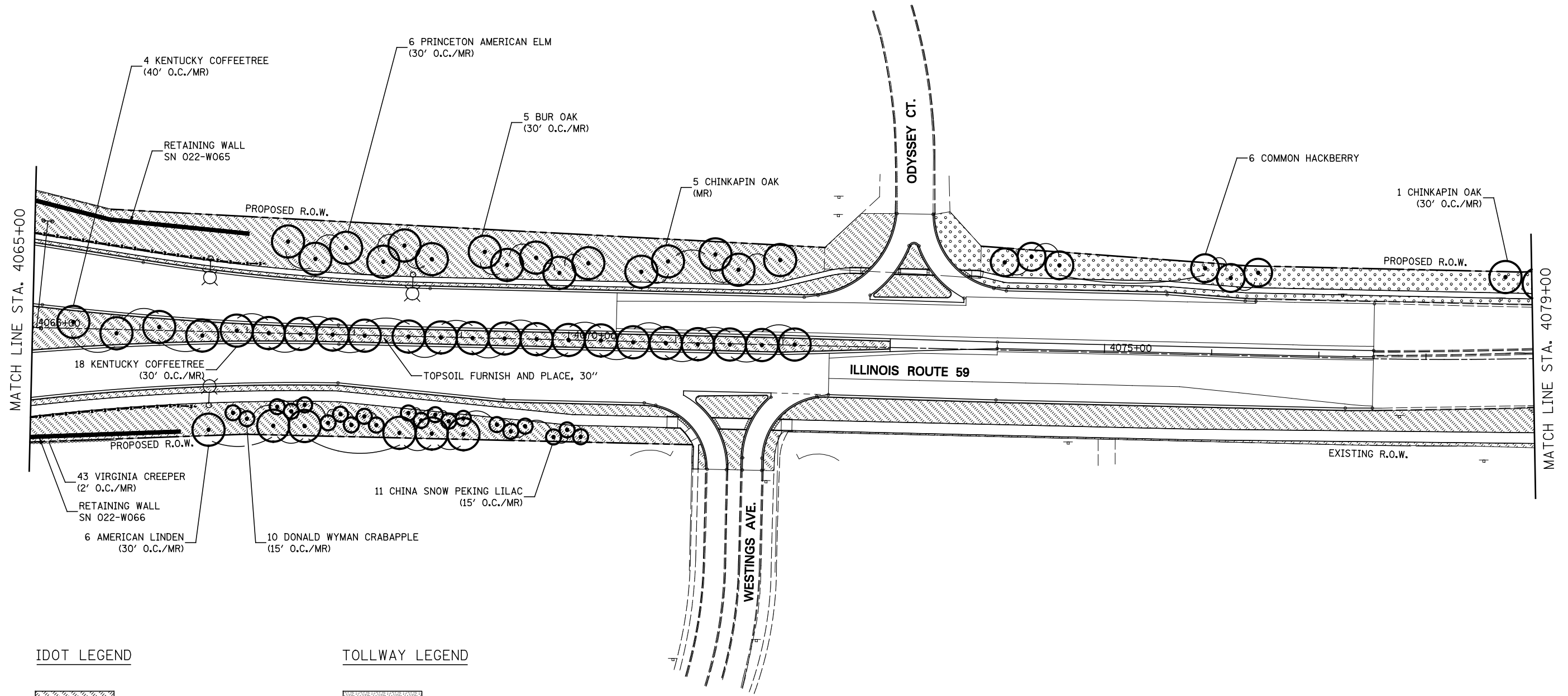

**IDOT LEGEND**

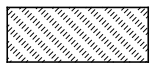
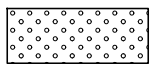
-  SODDING, SALT TOLERANT
-  SEEDING, CLASS 2A AND EROSION CONTROL BLANKET

**TOLLWAY LEGEND**

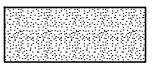
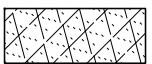
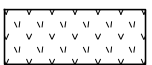
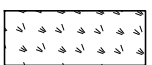
-  SEEDING, CLASS 2E AND EROSION CONTROL BLANKET
-  SEEDING, CLASS 3E AND EROSION CONTROL BLANKET
-  SEEDING, CLASS 4B AND EROSION CONTROL BLANKET
-  SEEDING, CLASS 4F AND EROSION CONTROL BLANKET

**NOTES:**

1. 6" OF TOPSOIL SHALL BE PLACED IN ALL LANDSCAPED AREAS, UNLESS OTHERWISE NOTED ON THE PLANS. THIS WORK SHALL BE PAID FOR AS TOPSOIL EXCAVATION AND PLACEMENT.

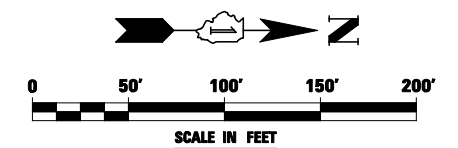

FILE NAME =	USER NAME = #USER#	DESIGNED <i>PJO</i>	REVISED -
#FILEL#		DRAWN <i>KES</i>	REVISED -
	PLOT SCALE = #SCALE#	CHECKED <i>JCM</i>	REVISED -
	PLOT DATE = #DATE#	DATE <i>10/15/2012</i>	REVISED -

**STATE OF ILLINOIS  
DEPARTMENT OF TRANSPORTATION**

**LANDSCAPE PLANS  
ILLINOIS ROUTE 59**

SCALE: SHEET NO. 3 OF 12 SHEETS STA. 4065+00 TO STA. 4079+00

F.A.P. RTE.	SECTION	COUNTY	TOTAL SHEETS	SHEET NO.
338	(112 & 113) WRS-5	DUPAGE	963	546
CONTRACT NO. 60I31				
ILLINOIS FED. AID PROJECT				

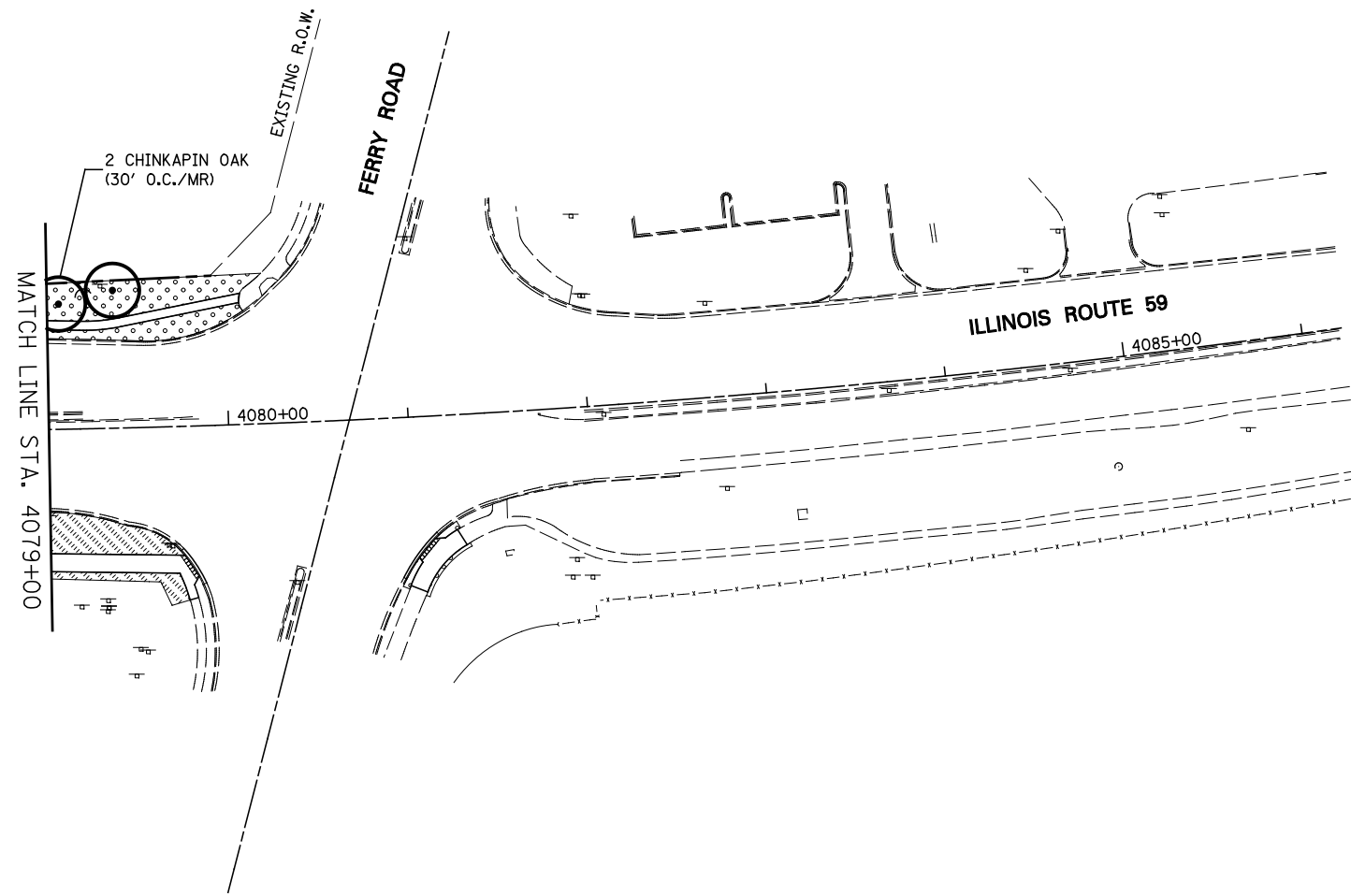

**IDOT LEGEND**



SODDING, SALT TOLERANT

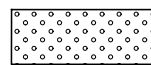

SEEDING, CLASS 2A AND EROSION CONTROL BLANKET

**TOLLWAY LEGEND**

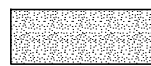

SEEDING, CLASS 2E AND EROSION CONTROL BLANKET

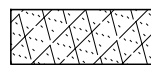

SEEDING, CLASS 3E AND EROSION CONTROL BLANKET

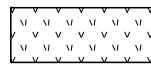

SEEDING, CLASS 4B AND EROSION CONTROL BLANKET



SEEDING, CLASS 4F AND EROSION CONTROL BLANKET

**NOTES:**

1. 6" OF TOPSOIL SHALL BE PLACED IN ALL LANDSCAPED AREAS, UNLESS OTHERWISE NOTED ON THE PLANS. THIS WORK SHALL BE PAID FOR AS TOPSOIL EXCAVATION AND PLACEMENT.

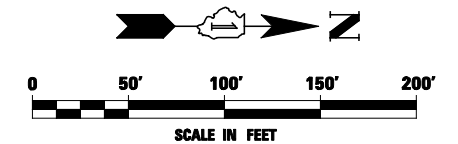

FILE NAME =	USER NAME = #USER#	DESIGNED <i>PJO</i>	REVISED -
#FILEL#		DRAWN <i>KES</i>	REVISED -
	PLOT SCALE = #SCALE#	CHECKED <i>JCM</i>	REVISED -
	PLOT DATE = #DATE#	DATE <i>10/15/2012</i>	REVISED -

**STATE OF ILLINOIS  
DEPARTMENT OF TRANSPORTATION**

**LANDSCAPE PLANS  
ILLINOIS ROUTE 59**

SCALE: SHEET NO. 4 OF 12 SHEETS STA. 4079+00 TO STA. 4086+00

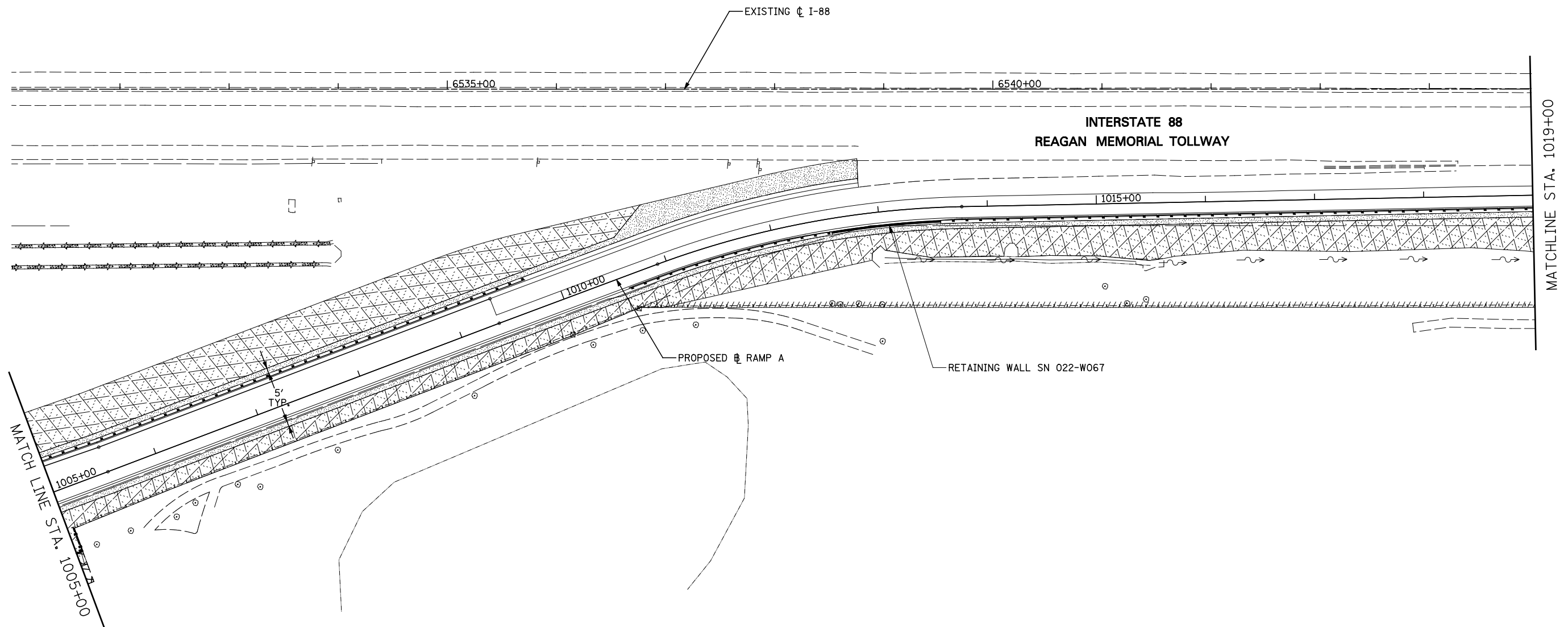

F.A.P. RTE.	SECTION	COUNTY	TOTAL SHEETS	SHEET NO.
338	(112 & 113) WRS-5	DUPAGE	963	547
				CONTRACT NO. 60I31
ILLINOIS FED. AID PROJECT				

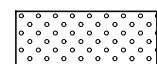

**IDOT LEGEND**

-  SODDING, SALT TOLERANT
-  SEEDING, CLASS 2A AND EROSION CONTROL BLANKET

**TOLLWAY LEGEND**

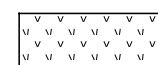
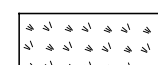
-  SEEDING, CLASS 2E AND EROSION CONTROL BLANKET
-  SEEDING, CLASS 3E AND EROSION CONTROL BLANKET
-  SEEDING, CLASS 4B AND EROSION CONTROL BLANKET
-  SEEDING, CLASS 4F AND EROSION CONTROL BLANKET

**NOTES:**

1. 6" OF TOPSOIL SHALL BE PLACED IN ALL LANDSCAPED AREAS, UNLESS OTHERWISE NOTED ON THE PLANS. THIS WORK SHALL BE PAID FOR AS TOPSOIL EXCAVATION AND PLACEMENT.

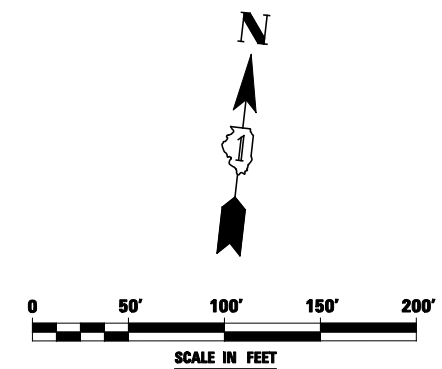

FILE NAME =	USER NAME = \$USER*	DESIGNED <i>PJO</i>	REVISED -
\$FILEL\$		DRAWN <i>KES</i>	REVISED -
	PLOT SCALE = \$SCALE*	CHECKED <i>JCM</i>	REVISED -
	PLOT DATE = \$DATE*	DATE <i>10/15/2012</i>	REVISED -

**STATE OF ILLINOIS  
DEPARTMENT OF TRANSPORTATION**

**LANDSCAPE PLANS  
RAMP A**

SCALE: SHEET NO. 5 OF 12 SHEETS STA. 1005+00 TO STA. 1019+00

F.A.P. RTE.	SECTION	COUNTY	TOTAL SHEETS	SHEET NO.
338	(112 & 113) WRS-5	DUPAGE	963	548
CONTRACT NO. 60I31				
ILLINOIS FED. AID PROJECT				



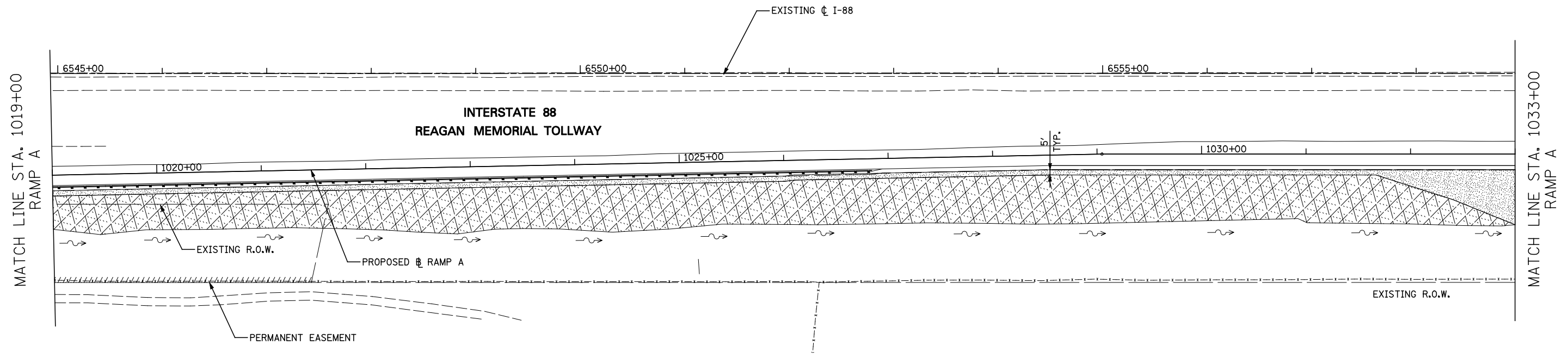

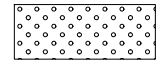

**IDOT LEGEND**

-  SODDING, SALT TOLERANT
-  SEEDING, CLASS 2A AND EROSION CONTROL BLANKET

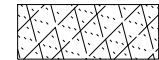
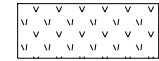
**TOLLWAY LEGEND**

-  SEEDING, CLASS 2E AND EROSION CONTROL BLANKET
-  SEEDING, CLASS 3E AND EROSION CONTROL BLANKET
-  SEEDING, CLASS 4B AND EROSION CONTROL BLANKET
-  SEEDING, CLASS 4F AND EROSION CONTROL BLANKET

**NOTES:**

1. 6" OF TOPSOIL SHALL BE PLACED IN ALL LANDSCAPED AREAS, UNLESS OTHERWISE NOTED ON THE PLANS. THIS WORK SHALL BE PAID FOR AS TOPSOIL EXCAVATION AND PLACEMENT.

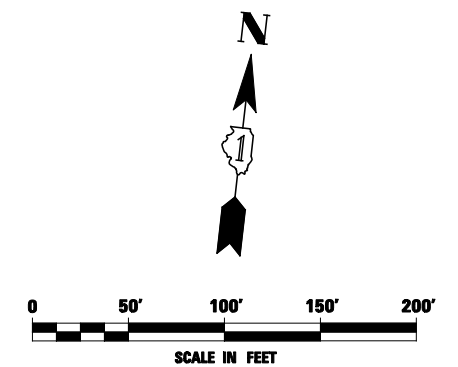

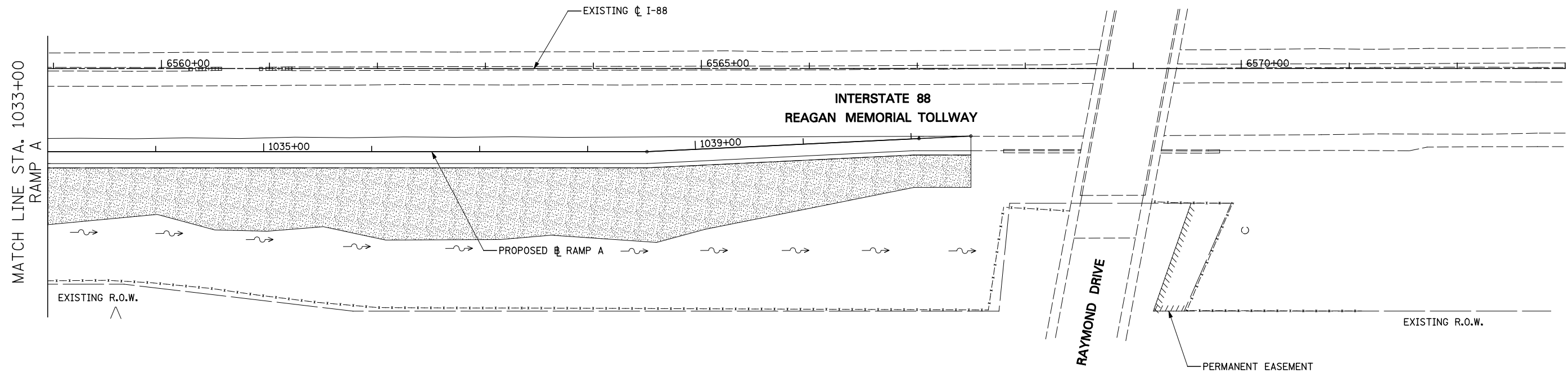

FILE NAME = #FILEL#	USER NAME = #USER#	DESIGNED <i>PJO</i>	REVISED -	<b>STATE OF ILLINOIS DEPARTMENT OF TRANSPORTATION</b>	<b>LANDSCAPE PLANS RAMP A</b>	F.A.P. RTE.	SECTION	COUNTY	TOTAL SHEETS	SHEET NO.
	PLOT SCALE = #SCALE#	CHECKED <i>JCM</i>	REVISED -			338	(112 & 113) WRS-5	DUPAGE	963	549
PLOT DATE = #DATE#	DATE <i>10/15/2012</i>	REVISED -	CONTRACT NO. 60I31							
					SCALE:	SHEET NO. 6 OF 12 SHEETS		STA. 1019+00 TO STA. 1033+00		ILLINOIS FED. AID PROJECT

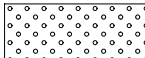

**IDOT LEGEND**

-  SODDING, SALT TOLERANT
-  SEEDING, CLASS 2A AND EROSION CONTROL BLANKET

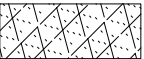
**TOLLWAY LEGEND**

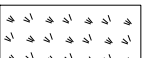
-  SEEDING, CLASS 2E AND EROSION CONTROL BLANKET
-  SEEDING, CLASS 3E AND EROSION CONTROL BLANKET
-  SEEDING, CLASS 4B AND EROSION CONTROL BLANKET
-  SEEDING, CLASS 4F AND EROSION CONTROL BLANKET

**NOTES:**

1. 6" OF TOPSOIL SHALL BE PLACED IN ALL LANDSCAPED AREAS, UNLESS OTHERWISE NOTED ON THE PLANS. THIS WORK SHALL BE PAID FOR AS TOPSOIL EXCAVATION AND PLACEMENT.

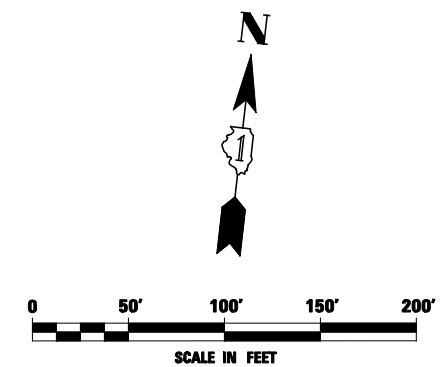

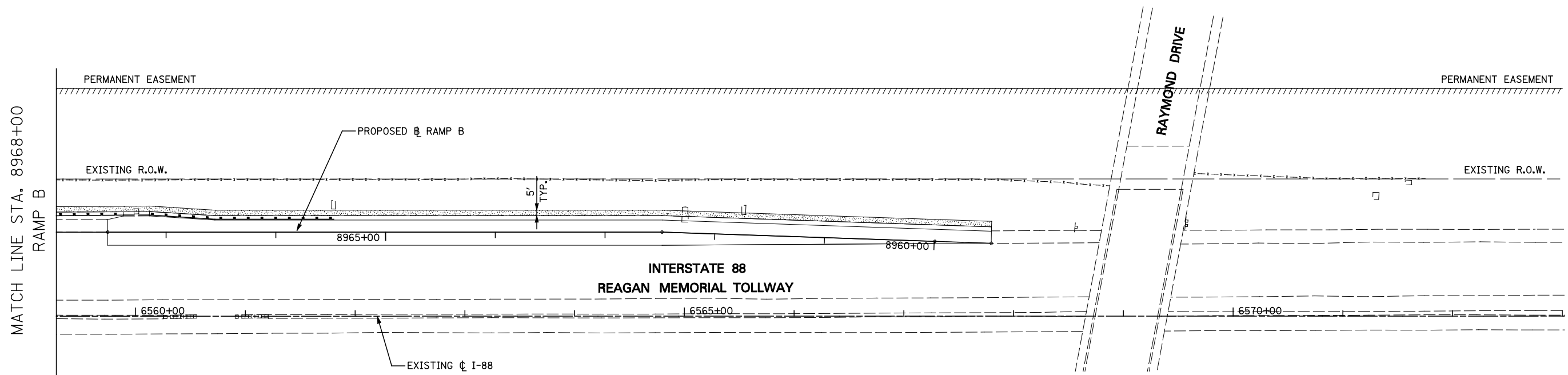

FILE NAME = #FILE#	USER NAME = #USER#	DESIGNED <i>PJO</i>	REVISED -	<b>STATE OF ILLINOIS DEPARTMENT OF TRANSPORTATION</b>	<b>LANDSCAPE PLANS RAMP A</b>	F.A.P. RTE.	SECTION	COUNTY	TOTAL SHEETS	SHEET NO.	
		DRAWN <i>KES</i>	REVISED -			338	(112 & 113) WRS-5	DUPAGE	963	550	
		CHECKED <i>JCM</i>	REVISED -			CONTRACT NO. 60I31					
		DATE <i>10/15/2012</i>	REVISED -			ILLINOIS FED. AID PROJECT					
				SCALE:		SHEET NO. 7 OF 12 SHEETS		STA. 1033+00 TO STA. 1041+55			

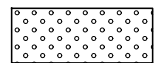

**IDOT LEGEND**

-  SODDING, SALT TOLERANT
-  SEEDING, CLASS 2A AND EROSION CONTROL BLANKET

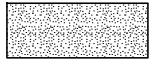
**TOLLWAY LEGEND**

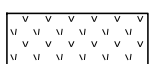
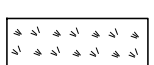
-  SEEDING, CLASS 2E AND EROSION CONTROL BLANKET
-  SEEDING, CLASS 3E AND EROSION CONTROL BLANKET
-  SEEDING, CLASS 4B AND EROSION CONTROL BLANKET
-  SEEDING, CLASS 4F AND EROSION CONTROL BLANKET

**NOTES:**

1. 6" OF TOPSOIL SHALL BE PLACED IN ALL LANDSCAPED AREAS, UNLESS OTHERWISE NOTED ON THE PLANS. THIS WORK SHALL BE PAID FOR AS TOPSOIL EXCAVATION AND PLACEMENT.

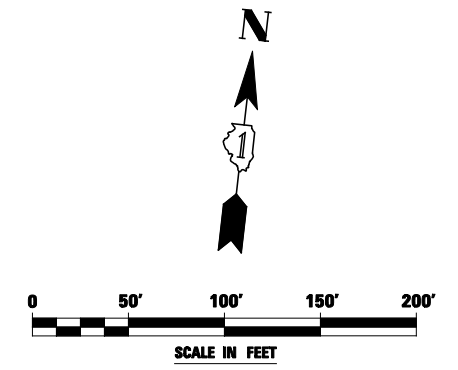

FILE NAME = #FILEL#	USER NAME = #USER#	DESIGNED <i>PJO</i>	REVISED -	<b>STATE OF ILLINOIS DEPARTMENT OF TRANSPORTATION</b>	<b>LANDSCAPE PLANS RAMP B</b>	F.A.P. RTE.	SECTION	COUNTY	TOTAL SHEETS	SHEET NO.	
		DRAWN <i>KES</i>	REVISED -			338	(112 & 113) WRS-5	DUPAGE	963	551	
		CHECKED <i>JCM</i>	REVISED -			CONTRACT NO. 60I31					
		DATE <i>10/15/2012</i>	REVISED -			ILLINOIS FED. AID PROJECT					
				SCALE:		SHEET NO. 8 OF 12 SHEETS		STA. 8959+48 TO STA. 8968+00			

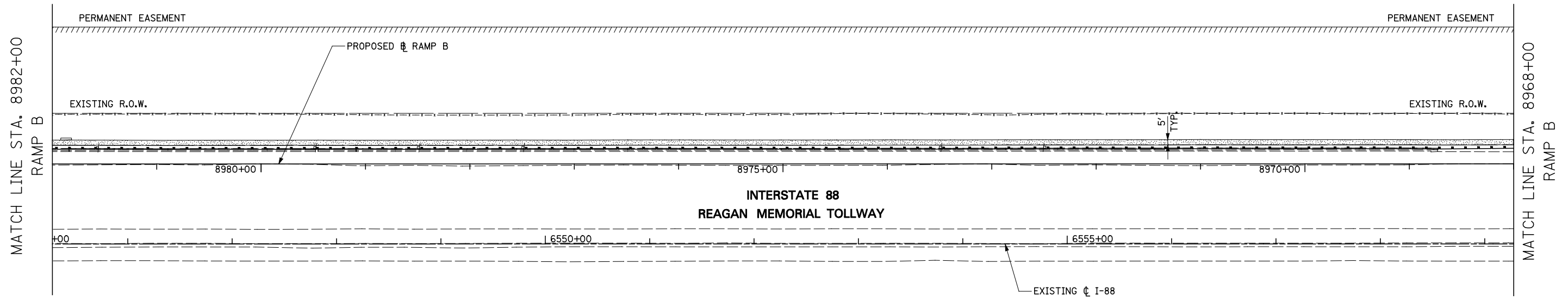

IDOT LEGEND

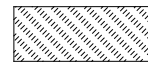
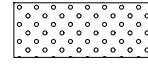
-  SODDING, SALT TOLERANT
-  SEEDING, CLASS 2A AND EROSION CONTROL BLANKET

TOLLWAY LEGEND

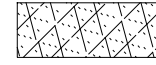
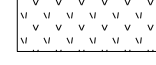
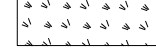
-  SEEDING, CLASS 2E AND EROSION CONTROL BLANKET
-  SEEDING, CLASS 3E AND EROSION CONTROL BLANKET
-  SEEDING, CLASS 4B AND EROSION CONTROL BLANKET
-  SEEDING, CLASS 4F AND EROSION CONTROL BLANKET

NOTES:

1. 6" OF TOPSOIL SHALL BE PLACED IN ALL LANDSCAPED AREAS, UNLESS OTHERWISE NOTED ON THE PLANS. THIS WORK SHALL BE PAID FOR AS TOPSOIL EXCAVATION AND PLACEMENT.

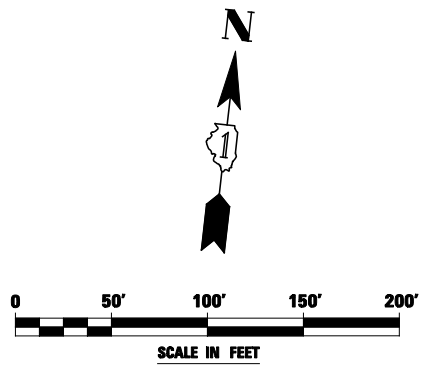

FILE NAME = #FILEL#	USER NAME = #USER#	DESIGNED <i>PJO</i>	REVISED -	<b>STATE OF ILLINOIS DEPARTMENT OF TRANSPORTATION</b>	<b>LANDSCAPE PLANS RAMP B</b>	F.A.P. RTE.	SECTION	COUNTY	TOTAL SHEETS	SHEET NO.	
		DRAWN <i>KES</i>	REVISED -			338	(112 & 113) WRS-5	DUPAGE	963	552	
		CHECKED <i>JCM</i>	REVISED -			CONTRACT NO. 60I31					
		DATE <i>10/15/2012</i>	REVISED -			ILLINOIS FED. AID PROJECT					
				SCALE:	SHEET NO. 9 OF 12 SHEETS	STA. 8968+00	TO STA. 8982+00				

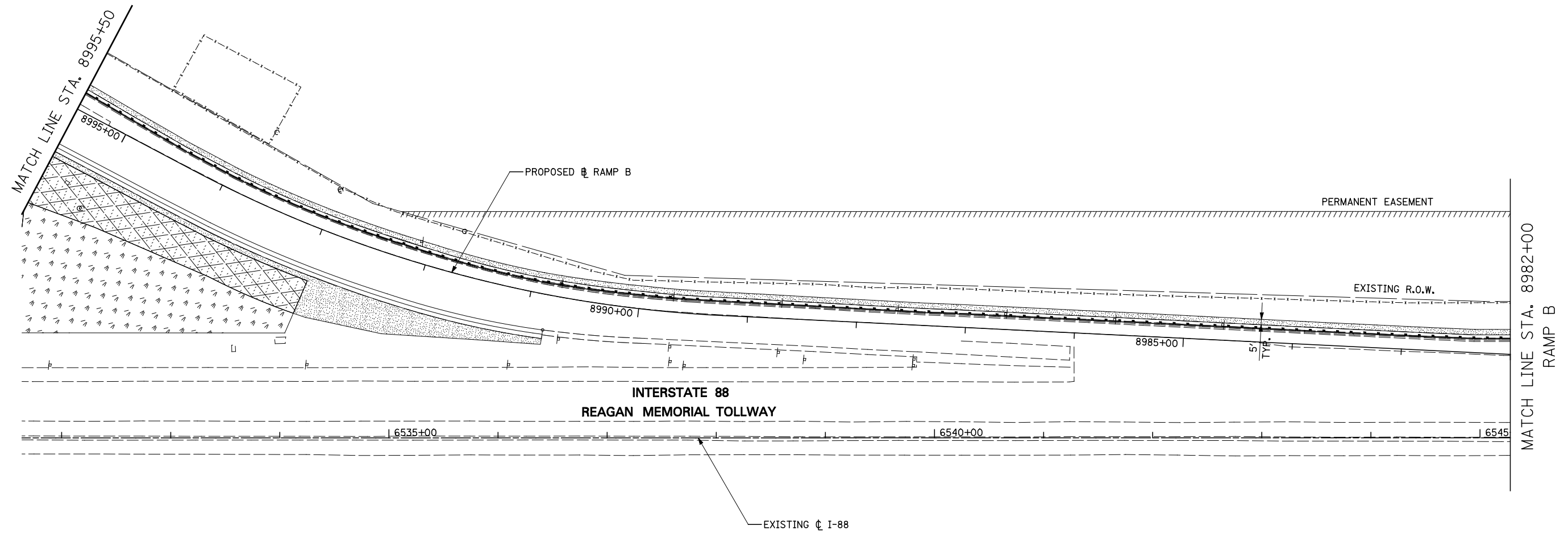

**IDOT LEGEND**



SODDING, SALT TOLERANT

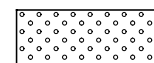

SEEDING, CLASS 2A AND  
EROSION CONTROL BLANKET

**TOLLWAY LEGEND**



SEEDING, CLASS 2E AND  
EROSION CONTROL BLANKET

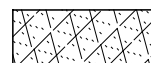

SEEDING, CLASS 3E AND  
EROSION CONTROL BLANKET



SEEDING, CLASS 4B AND  
EROSION CONTROL BLANKET

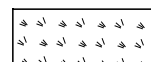

SEEDING, CLASS 4F AND  
EROSION CONTROL BLANKET

**NOTES:**

1. 6" OF TOPSOIL SHALL BE PLACED IN ALL LANDSCAPED AREAS, UNLESS OTHERWISE NOTED ON THE PLANS. THIS WORK SHALL BE PAID FOR AS TOPSOIL EXCAVATION AND PLACEMENT.

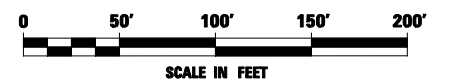

FILE NAME =	USER NAME = \$USER*	DESIGNED <i>PJO</i>	REVISED -
\$FILEL\$		DRAWN <i>KES</i>	REVISED -
	PLOT SCALE = \$SCALE*	CHECKED <i>JCM</i>	REVISED -
	PLOT DATE = \$DATE*	DATE <i>10/15/2012</i>	REVISED -

**STATE OF ILLINOIS  
DEPARTMENT OF TRANSPORTATION**

**LANDSCAPE PLANS  
RAMP B**

SCALE: SHEET NO. 10 OF 12 SHEETS STA. 8982+00 TO STA. 8995+50

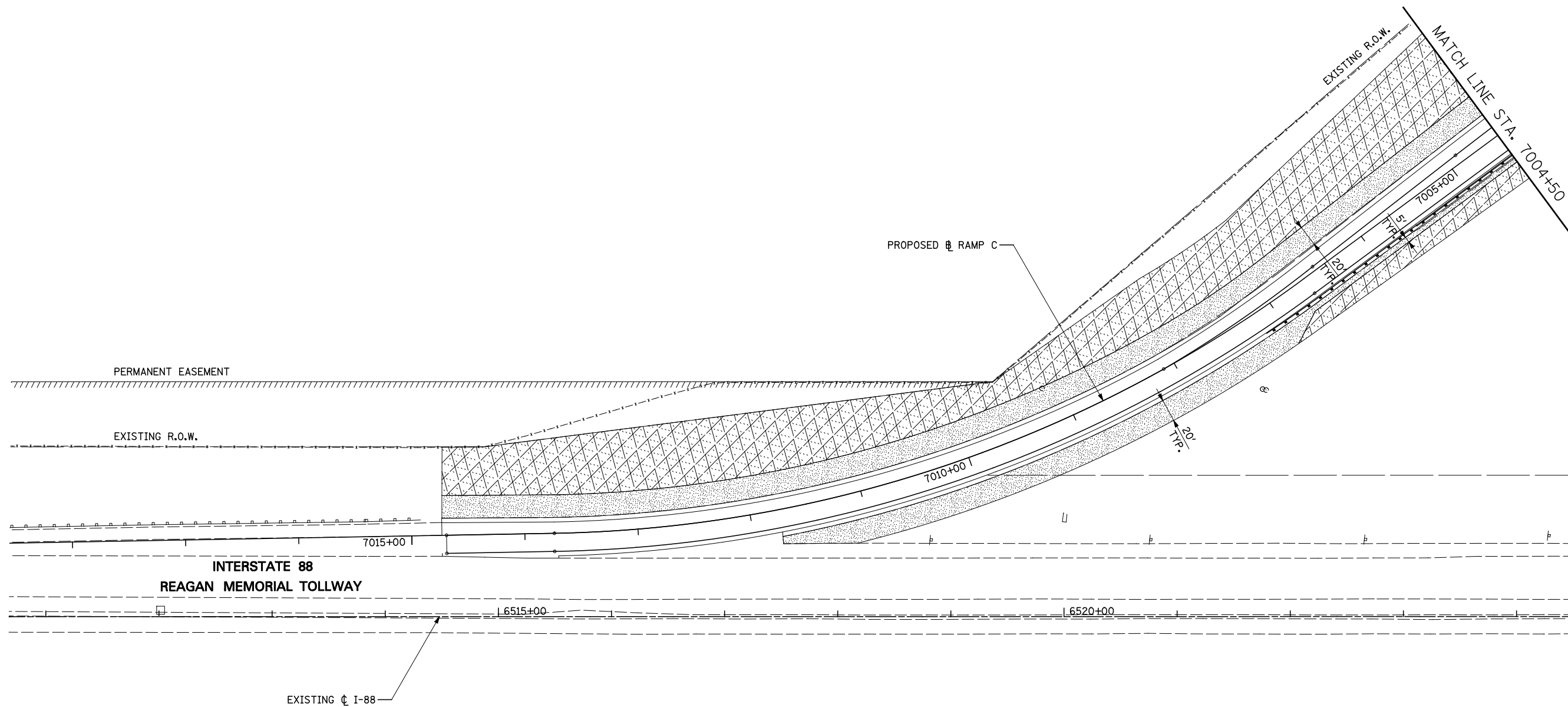

F.A.P. RTE.	SECTION	COUNTY	TOTAL SHEETS	SHEET NO.
338	(112 & 113) WRS-5	DUPAGE	963	553
CONTRACT NO. 60I31				
ILLINOIS FED. AID PROJECT				

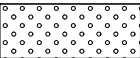

**IDOT LEGEND**

-  SODDING, SALT TOLERANT
-  SEEDING, CLASS 2A AND EROSION CONTROL BLANKET

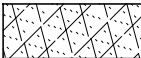
**TOLLWAY LEGEND**

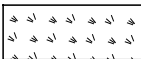
-  SEEDING, CLASS 2E AND EROSION CONTROL BLANKET
-  SEEDING, CLASS 3E AND EROSION CONTROL BLANKET
-  SEEDING, CLASS 4B AND EROSION CONTROL BLANKET
-  SEEDING, CLASS 4F AND EROSION CONTROL BLANKET

**NOTES:**

1. 6" OF TOPSOIL SHALL BE PLACED IN ALL LANDSCAPED AREAS, UNLESS OTHERWISE NOTED ON THE PLANS. THIS WORK SHALL BE PAID FOR AS TOPSOIL EXCAVATION AND PLACEMENT.

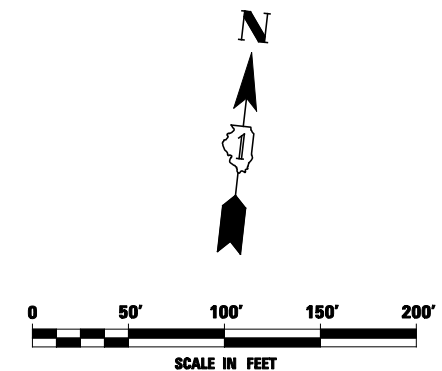

FILE NAME =	USER NAME = \$USER*	DESIGNED <i>PJO</i>	REVISED -
\$FILEL\$		DRAWN <i>KES</i>	REVISED -
	PLOT SCALE = \$SCALE*	CHECKED <i>JCM</i>	REVISED -
	PLOT DATE = \$DATE*	DATE <i>10/15/2012</i>	REVISED -

**STATE OF ILLINOIS  
DEPARTMENT OF TRANSPORTATION**

**LANDSCAPE PLANS  
RAMP C**

SCALE: SHEET NO. 11 OF 12 SHEETS STA. 7004+50 TO STA. 7018+00

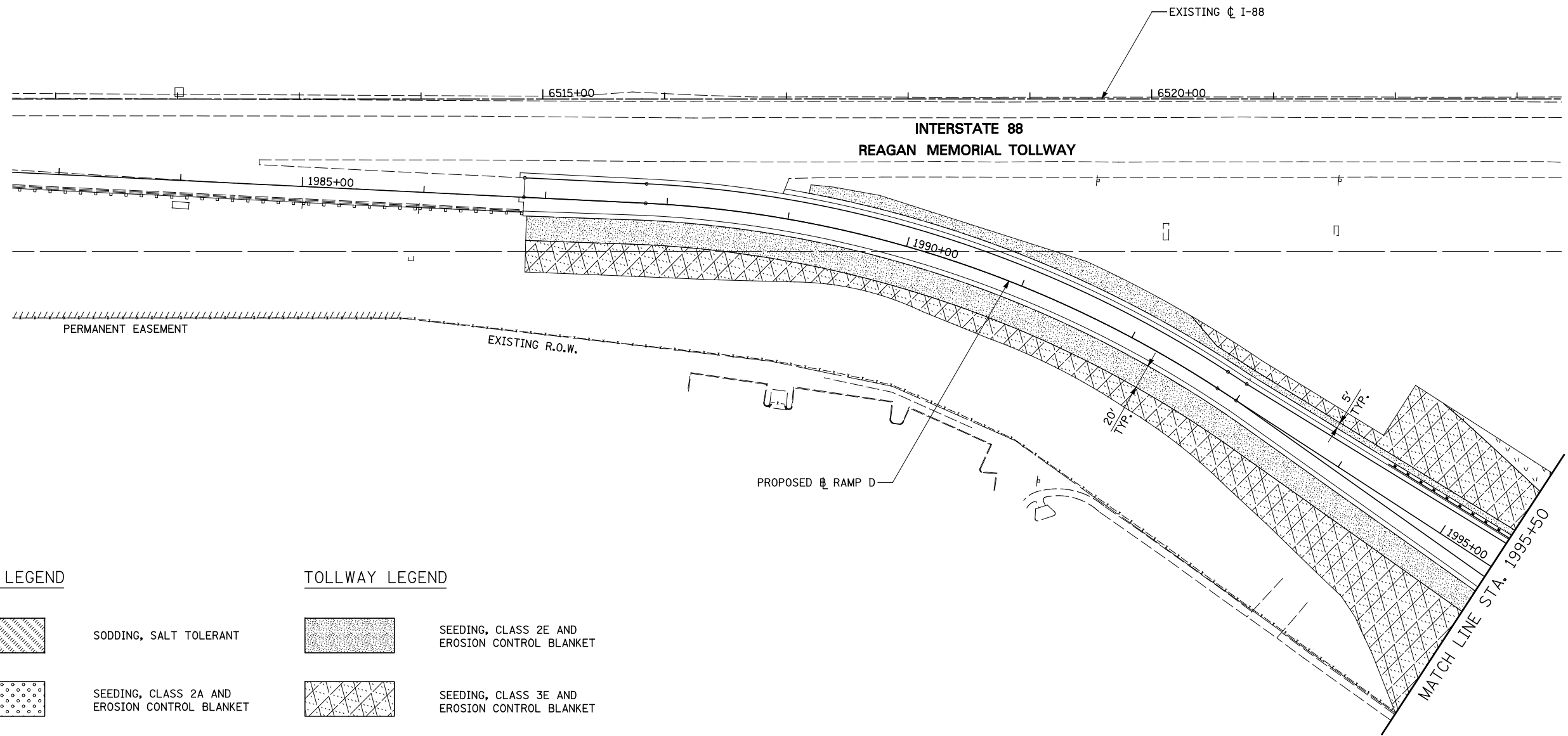

F.A.P. RTE.	SECTION	COUNTY	TOTAL SHEETS	SHEET NO.
338	(112 & 113) WRS-5	DUPAGE	963	554
CONTRACT NO. 60I31				
ILLINOIS FED. AID PROJECT				

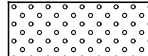

**IDOT LEGEND**

-  SODDING, SALT TOLERANT
-  SEEDING, CLASS 2A AND EROSION CONTROL BLANKET

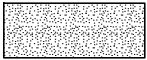
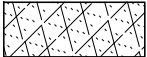
**TOLLWAY LEGEND**

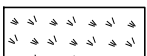
-  SEEDING, CLASS 2E AND EROSION CONTROL BLANKET
-  SEEDING, CLASS 3E AND EROSION CONTROL BLANKET
-  SEEDING, CLASS 4B AND EROSION CONTROL BLANKET
-  SEEDING, CLASS 4F AND EROSION CONTROL BLANKET





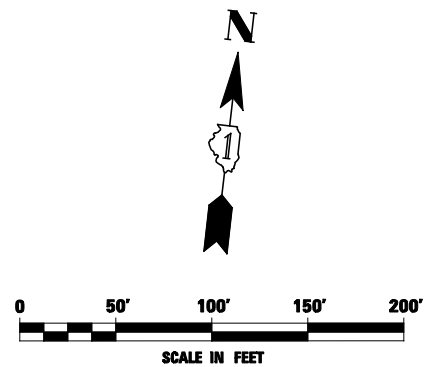









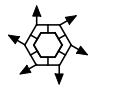







**NOTES:**

1. 6" OF TOPSOIL SHALL BE PLACED IN ALL LANDSCAPED AREAS, UNLESS OTHERWISE NOTED ON THE PLANS. THIS WORK SHALL BE PAID FOR AS TOPSOIL EXCAVATION AND PLACEMENT.



FILE NAME = #FILE#	USER NAME = #USER#	DESIGNED <i>PJO</i>	REVISED -	<b>STATE OF ILLINOIS DEPARTMENT OF TRANSPORTATION</b>	<b>LANDSCAPE PLANS RAMP D</b>	F.A.P. RTE.	SECTION	COUNTY	TOTAL SHEETS	SHEET NO.	
		DRAWN <i>KES</i>	REVISED -			338	(112 & 113) WRS-5	DUPAGE	963	555	
		CHECKED <i>JCM</i>	REVISED -			CONTRACT NO. 60I31					
		DATE <i>10/15/2012</i>	REVISED -			ILLINOIS FED. AID PROJECT					
				SCALE:	SHEET NO. 12 OF 12 SHEETS	STA. 1981+00	TO STA. 1995+50				

SYMBOL LIST

-  EXISTING COMBINATION LIGHTING - TRAFFIC SIGNAL POLE
-  NEW COMBINATION LIGHTING - TRAFFIC SIGNAL POLE
-  EXISTING LIGHT POLE TO REMAIN
-  EXISTING LIGHT POLE TO BE REMOVED AND SALVAGED
-  NEW LIGHT POLE WITH LUMINAIRE, SODIUM VAPOR, HORIZONTAL MOUNT, 400 WATT, 47.5' M.H. AND 12' MAST ARM
-  HIGH MAST LIGHTING 90' M.H., 750W HPS, 240V LUMINAIRES. NUMBER OF ARMS/LUMINAIRES AS SHOWN ON PLANS
-  SURVEILANCE CCTV CAMERA
-  EXISTING LIGHTING CONTROLLER
-  NEW LIGHTING CONTROLLER
-  NEW HANDHOLE
-  NEW COMMUNICATION VAULT
-  NEW LIGHTING JUNCTION BOX. TYPE AND SIZE AS NOTED
-  EXISTING UTILITY POLE
-  TEMPORARY WOOD POLE, 60 FT., CLASS 4, UNLESS OTHERWISE NOTED
-  GROUND ROD
-  UTILITY TRANSFORMER POLE MOUNTED
-  UNIT DUCT. NO. AND SIZE OF WIRES AS NOTED ON PLANS
-  WIRING IN CONDUIT ATTACHED TO STRUCTURE
-  AERIAL CABLE
-  FIBER OPTIC CABLE - UNDERGROUND
-  TEMPORARY AERIAL FIBER OPTIC CABLE WITH MESSENGER WIRE
-  CONDUIT CONCEALED
-  CONTROL CABINET CIRCUITRY POLE NUMBER

ABBREVIATIONS

- A AMPS
- DIA DIAMETER
- C CONDUIT
- GND GROUND
- FT FEET
- HPS HIGH PRESSURE SODIUM
- IDOT ILLINOIS DEPARTMENT OF TRASPORTATION
- LT LEFT
- MC MEDIUM CUTOFF
- P PUSHED
- PC PHOTO CONTROL
- PH PHASE
- PVC POLYVINYL CHLORIDE
- RGS RIGID GALVANIZED STEEL
- RT RIGHT
- STA STATION
- UNO UNLESS NOTED OTHERWISE
- V VOLTS
- W WATTS

GENERAL NOTES

1. SPLICING OF CONDUCTORS SHALL BE IN POLE BASES OR WEATHER TIGHT JUNCTION BOXES ONLY. SPLICES BELOW GRADE WILL NOT BE PERMITTED.
2. LIGHTING CIRCUITS SHALL BE WIRED IN ACCORDANCE WITH THE PLANS. DEVIATIONS WILL NOT BE PERMITTED WITHOUT PRIOR APPROVAL OF THE ENGINEER.
3. THE CONTRACTOR SHALL REQUEST A FORMAL MAINTENANCE TRANSFER BEFORE ANY WORK BEGINS. THE CONTRACTOR SHALL CONTACT THE ILLINOIS DEPARTMENT OF TRANSPORTATION - NEIL THAKKAR AT (708) 524-2145.
4. THE CONTRACTOR SHALL TAKE ALL NECESSARY MEASURES TO RESTORE ANY SPECIALIZED LADSCAPING (DECORATIVE ROCKS, PLANTS, ETC.).
5. ALL WORK SHALL CONFORM TO THE LATEST IDOT AND DISTRICT 1 STANDARDS, SPECIAL PROVISIONS, SUPPLEMENTAL SPECIFICATIONS, THE NATIONAL ELECTRICAL CODE, AND THE NATIONAL ELECTRICAL SAFETY CODE.
6. ALL ELECTRICAL EQUIPMENT SHALL BE UL LISTED AND LABELED.
7. ALL CONDUITS SHALL BE SEALED.
8. ALL CIRCUIT WIRES SHALL BE LABELED WITH CIRCUIT IDENTIFICATION.
9. ALL LAMPS SHALL BE FURNISHED AS PART OF THE CONTRACT.
10. CIRCUITS SHALL BE TESTED PER SPECIFICATIONS.
11. THE LOCATIONS OF ALL PROPOSED EQUIPMENT ARE ILLUSTRATED DIAGRAMMATICALLY. THE ACTUAL LOCATION IN THE FIELD SHALL MEET THE APPROVAL OF THE ENGINEER.
12. ALL MEASUREMENTS ARE APPROXIMATE. THE CONTRACTOR SHALL VERIFY MEASUREMENTS IN THE FIELD.
13. IT SHALL BE THE RESPONSIBILITY OF THE CONTRACTOR TO VERIFY THE EXISTING INSTALLATIONS AND DATA PRIOR TO BIDDING.
14. THE CONTRACTOR MUST MAINTAIN SAFE EQUIPMENT AND WORKING CLEARANCES FROM THE EXISTING COMED OVERHEAD ELECTRIC LINES. THE CONTRACTOR SHALL PLAN HIS WORK CONSIDERING COMED'S LINES TO BE IN SERVICE AND ENERGIZED THROUGHOUT THE CONSTRUCTION PERIOD.
15. THE CONTRACTOR SHALL REMOVE CABLES FROM ALL EXISTING UNIT DUCTS. EXISTING UNIT DUCTS SHALL BE ABANDONED IN PLACE.
16. THE COST OF SPLICING TEMPORARY CONDUCTORS TO EXISTING CONDUCTORS IN EXISTING POLES SHALL BE INCIDENTAL TO THE PAY ITEM FOR AERIAL CABLE.
17. GROUNDING CONDUCTORS SHALL BE CONTINUOUS.
18. ALL NEW UNIT DUCTS AND CONDUITS SHALL BE PLACED A MINIMUM OF 30" BENEATH THE GROUND SURFACE (FINAL GRADE).

FILE NAME = #FILEL#	USER NAME = #USER#	DESIGNED <i>MCP</i>	REVISED -	<b>STATE OF ILLINOIS DEPARTMENT OF TRANSPORTATION</b>	<b>I.D.O.T. ELECTRICAL SYMBOLS, ABBREVIATIONS AND GENERAL NOTES</b>	F.A.P. RTE.	SECTION	COUNTY	TOTAL SHEETS	SHEET NO.	
		DRAWN <i>MLB</i>	REVISED -			338	(112 & 113) WRS-5	DUPAGE	963	556	
		CHECKED <i>MCP</i>	REVISED -			<b>LT-01</b>			CONTRACT NO. 60I31		
		PLOT DATE = #DATE#	DATE <i>10/15/2012</i>			SCALE: AS SHOWN	SHEET NO. 1 OF 1 SHEETS	STA.	TO STA.		ILLINOIS FED. AID PROJECT



1. FOR SYMBOL LIST AND GENERAL ELECTRICAL NOTES, SEE SHEET LT-01.
2. INSTALL CCTV DOME CAMERA (TEMPORARY), CCTV EQUIPMENT, FIBER OPTIC DISTRIBUTION AND CCTV VIDEO DECODER ON TRAFFIC SIGNAL POLE. POWER THE CABINET FROM THE TRAFFIC SIGNAL CONTROL CABINET ON THE SAME POLE. RUN POWER CABLE (BELDEN TYPE 5140U1) AND VIDEO/SIGNAL CABLE (BELDEN TYPE 5499X5) ALL IN (1) 1" RGS CONDUIT ATTACHED TO THE POLE BETWEEN CABINET AND CCTV CAMERA AS PART OF CCTV DOME CAMERA PAY ITEM. SEE TEMPORARY TRAFFIC SIGNAL DRAWINGS FOR EXACT POLE LOCATION.
3. FIBER OPTIC CABLES SHALL BE RUN DOWN THE WOOD POLE AND UNDERGROUND TO THE NEW COMMUNICATIONS VAULT OF G4S NETWORK IN A 2" RGS CONDUIT.
4. TEMPORARY WOOD POLES, CAMERA, CABINET AND FIBER OPTIC SHALL BE REMOVED WHEN PERMANENT CAMERAS IS OPERATIONAL. WORK SHALL BE INCLUDED IN "REMOVE TEMPORARY WOOD POLE" PAY ITEM.

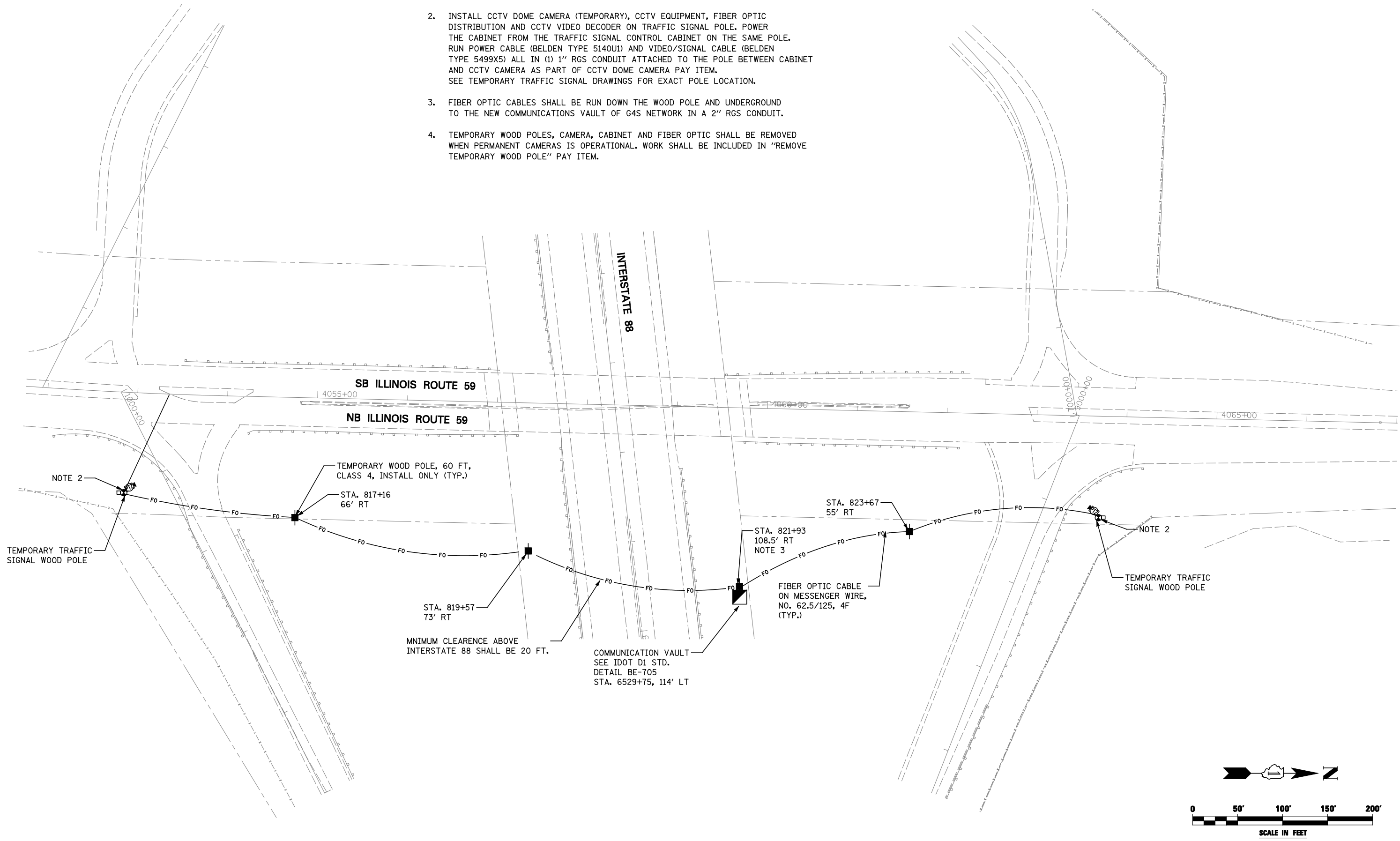

FILE NAME = #FILE#	USER NAME = #USER#	DESIGNED MCP	REVISED -
		DRAWN MLB	REVISED -
		CHECKED MCP	REVISED -
		DATE 10/15/2012	REVISED -

**STATE OF ILLINOIS  
DEPARTMENT OF TRANSPORTATION**

<b>IDOT TEMPORARY CCTV CAMERA INSTALLATION PLAN</b>			
<b>ILLINOIS ROUTE 59 AT INTERSTATE 88</b>			
SCALE: AS SHOWN	SHEET NO. 1 OF 1 SHEETS	STA. 4051+75	TO STA. 4067+00

F.A.P. RTE.	SECTION	COUNTY	TOTAL SHEETS	SHEET NO.
338	(112 & 113) WRS-5	DUPAGE	963	557
<b>LT-02</b>			CONTRACT NO. 60I31	
ILLINOIS FED. AID PROJECT				

**NOTES:**

1. ALL LIGHTING POLES AND WIRING SHALL BE INSTALLED AND POWERED UNDER CONTRACT 60I31.
2. FOR SYMBOL LIST AND GENERAL ELECTRICAL NOTES, SEE SHEET LT-01.
3. NOT USED.
4. UNIT DUCT, 600V, 3-1C NO. 4, 1/C NO.6 GROUND, (XLP-TYPE USE), 1 1/4" DIA. POLYETHYLENE.
5. LIGHTING/WIRING SHALL BE INSTALLED UNDER CONTRACT 60R31.
6. POLE SETBACK SHALL BE MEASURED FROM THE FACE OF CURB TO THE CENTER OF THE POLE.
7. INSTALL AND CAP CONDUIT ELBOW IN FOUNDATION FOR FUTURE CONNECTION TO THE INTERSECTION LIGHTING.

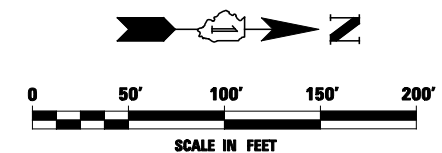
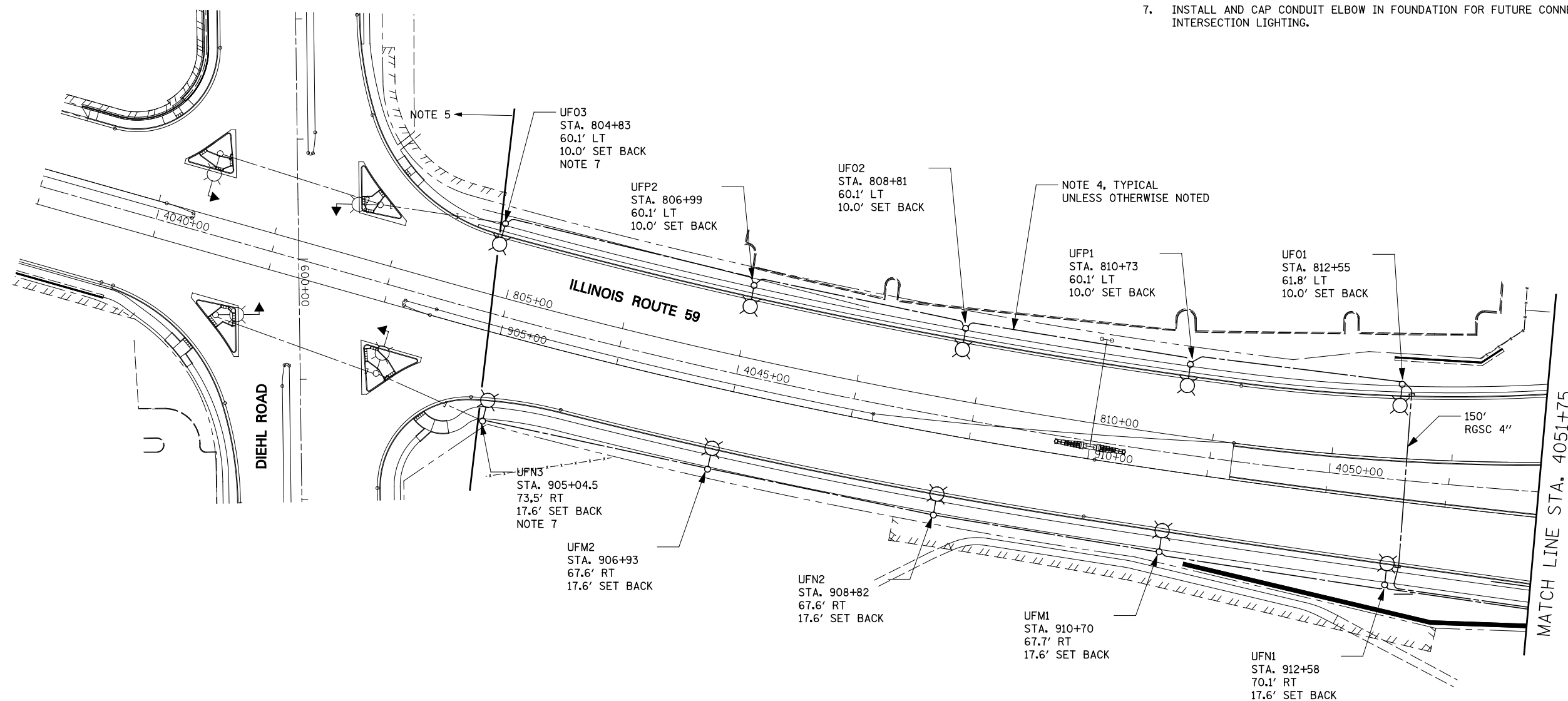

FILE NAME = #FILEL#	USER NAME = #USER#	DESIGNED MCP	REVISED -	<b>STATE OF ILLINOIS DEPARTMENT OF TRANSPORTATION</b>	<b>IDOT LIGHTING PLAN - ILLINOIS ROUTE 59</b>	F.A.P. RTE.	SECTION	COUNTY	TOTAL SHEETS	SHEET NO.
	DRAWN MLB	REVISIED -	338			(112 & 113) WRS-5	DUPAGE	963	558	
	CHECKED MCP	REVISIED -	<b>LT-03</b>			CONTRACT NO. 60I31		ILLINOIS FED. AID PROJECT		
	DATE 10/15/2012	REVISIED -	SCALE: AS SHOWN			SHEET NO. 1 OF 2 SHEETS	STA. 4039+00 TO STA. 4051+75			

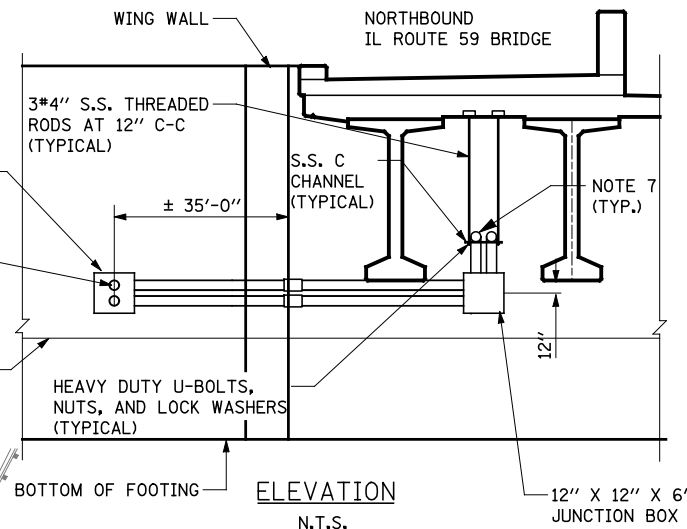
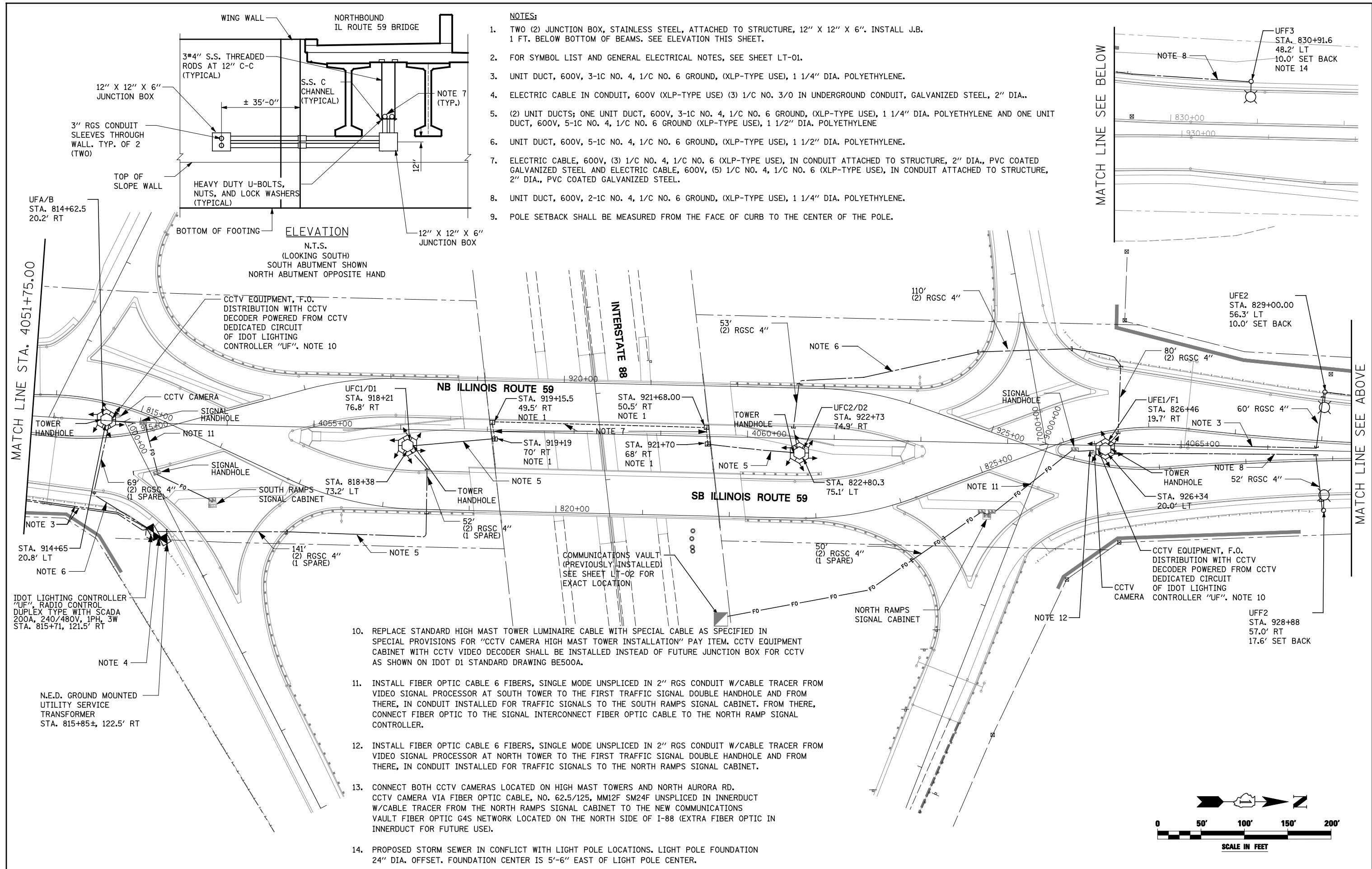

- NOTES:**
- TWO (2) JUNCTION BOX, STAINLESS STEEL, ATTACHED TO STRUCTURE, 12" X 12" X 6". INSTALL J.B. 1 FT. BELOW BOTTOM OF BEAMS. SEE ELEVATION THIS SHEET.
  - FOR SYMBOL LIST AND GENERAL ELECTRICAL NOTES, SEE SHEET LT-01.
  - UNIT DUCT, 600V, 3-1C NO. 4, 1/C NO. 6 GROUND, (XLP-TYPE USE), 1 1/4" DIA. POLYETHYLENE.
  - ELECTRIC CABLE IN CONDUIT, 600V (XLP-TYPE USE) (3) 1/C NO. 3/0 IN UNDERGROUND CONDUIT, GALVANIZED STEEL, 2" DIA..
  - (2) UNIT DUCTS; ONE UNIT DUCT, 600V, 3-1C NO. 4, 1/C NO. 6 GROUND, (XLP-TYPE USE), 1 1/4" DIA. POLYETHYLENE AND ONE UNIT DUCT, 600V, 5-1C NO. 4, 1/C NO. 6 GROUND (XLP-TYPE USE), 1 1/2" DIA. POLYETHYLENE
  - UNIT DUCT, 600V, 5-1C NO. 4, 1/C NO. 6 GROUND, (XLP-TYPE USE), 1 1/2" DIA. POLYETHYLENE.
  - ELECTRIC CABLE, 600V, (3) 1/C NO. 4, 1/C NO. 6 (XLP-TYPE USE), IN CONDUIT ATTACHED TO STRUCTURE, 2" DIA., PVC COATED GALVANIZED STEEL AND ELECTRIC CABLE, 600V, (5) 1/C NO. 4, 1/C NO. 6 (XLP-TYPE USE), IN CONDUIT ATTACHED TO STRUCTURE, 2" DIA., PVC COATED GALVANIZED STEEL.
  - UNIT DUCT, 600V, 2-1C NO. 4, 1/C NO. 6 GROUND, (XLP-TYPE USE), 1 1/4" DIA. POLYETHYLENE.
  - POLE SETBACK SHALL BE MEASURED FROM THE FACE OF CURB TO THE CENTER OF THE POLE.

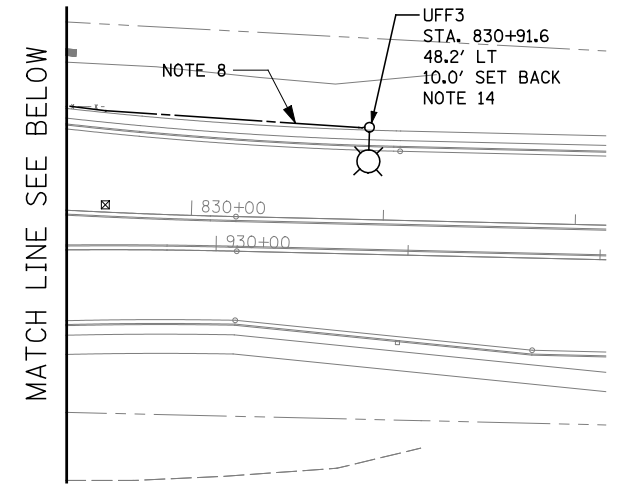

- REPLACE STANDARD HIGH MAST TOWER LUMINAIRE CABLE WITH SPECIAL CABLE AS SPECIFIED IN SPECIAL PROVISIONS FOR "CCTV CAMERA HIGH MAST TOWER INSTALLATION" PAY ITEM. CCTV EQUIPMENT CABINET WITH CCTV VIDEO DECODER SHALL BE INSTALLED INSTEAD OF FUTURE JUNCTION BOX FOR CCTV AS SHOWN ON IDOT D1 STANDARD DRAWING BES00A.
- INSTALL FIBER OPTIC CABLE 6 FIBERS, SINGLE MODE UNSPLICED IN 2" RGS CONDUIT W/CABLE TRACER FROM VIDEO SIGNAL PROCESSOR AT SOUTH TOWER TO THE FIRST TRAFFIC SIGNAL DOUBLE HANDHOLE AND FROM THERE, IN CONDUIT INSTALLED FOR TRAFFIC SIGNALS TO THE SOUTH RAMPS SIGNAL CABINET. FROM THERE, CONNECT FIBER OPTIC TO THE SIGNAL INTERCONNECT FIBER OPTIC CABLE TO THE NORTH RAMP SIGNAL CONTROLLER.
- INSTALL FIBER OPTIC CABLE 6 FIBERS, SINGLE MODE UNSPLICED IN 2" RGS CONDUIT W/CABLE TRACER FROM VIDEO SIGNAL PROCESSOR AT NORTH TOWER TO THE FIRST TRAFFIC SIGNAL DOUBLE HANDHOLE AND FROM THERE, IN CONDUIT INSTALLED FOR TRAFFIC SIGNALS TO THE NORTH RAMPS SIGNAL CABINET.
- CONNECT BOTH CCTV CAMERAS LOCATED ON HIGH MAST TOWERS AND NORTH AURORA RD. CCTV CAMERA VIA FIBER OPTIC CABLE, NO. 62.5/125, MM12F SM24F UNSPLICED IN INNERDUCT W/CABLE TRACER FROM THE NORTH RAMPS SIGNAL CABINET TO THE NEW COMMUNICATIONS VAULT FIBER OPTIC G4S NETWORK LOCATED ON THE NORTH SIDE OF I-88 (EXTRA FIBER OPTIC IN INNERDUCT FOR FUTURE USE).
- PROPOSED STORM SEWER IN CONFLICT WITH LIGHT POLE LOCATIONS. LIGHT POLE FOUNDATION 24" DIA. OFFSET. FOUNDATION CENTER IS 5'-6" EAST OF LIGHT POLE CENTER.

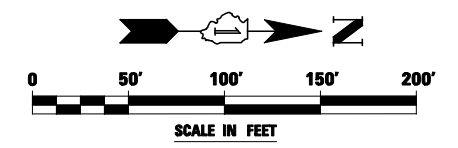

FILE NAME = #FILE#	USER NAME = #USER#	DESIGNED MCP	REVISED -	<b>STATE OF ILLINOIS DEPARTMENT OF TRANSPORTATION</b>	<b>IDOT LIGHTING PLAN - ILLINOIS ROUTE 59 AT INTERSTATE 88</b>	F.A.P. RTE.	SECTION	COUNTY	TOTAL SHEETS	SHEET NO.	
		DRAWN MLB	REVISED -			338	(112 & 113) WRS-5	DUPAGE	963	559	
		CHECKED MCP	REVISED -			<b>LT-04</b>		CONTRACT NO. 60I31			
		DATE 10/15/2012	REVISED -			SCALE: AS SHOWN		SHEET NO. 2 OF 2 SHEETS		STA. 4051+75 TO STA. 4067+00	

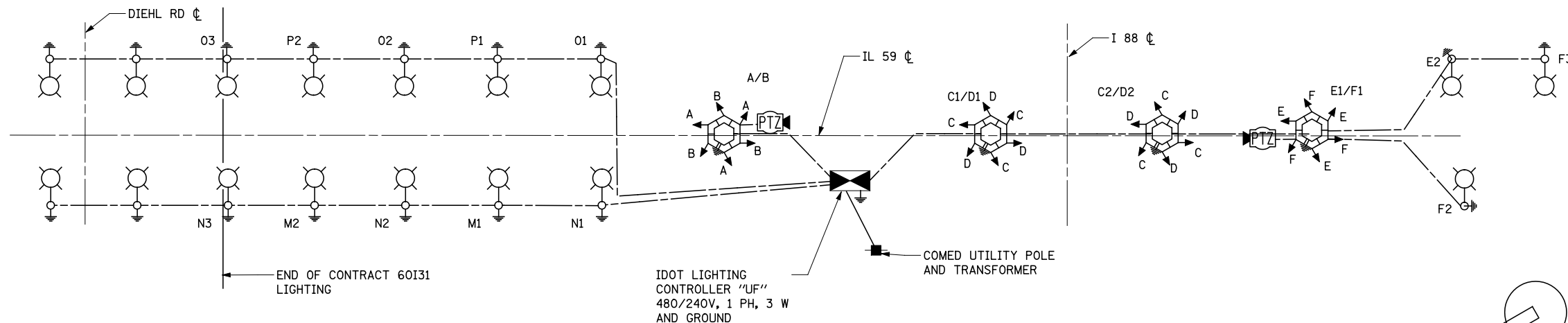

**IDOT LIGHTING CONTROLLER "UF" SINGLE LINE DIAGRAM**  
NOT TO SCALE

**IDOT BILL OF MATERIAL**

DESIGNATION	UNIT OF MEASURE	QUANTITY
ELECTRIC SERVICE INSTALLATION	EACH	1
ELECTRIC UTILITY SERVICE CONNECTION	L SUM	1
UNDERGROUND CONDUIT, GALVANIZED STEEL, 2" DIA.	FOOT	481
UNDERGROUND CONDUIT, GALVANIZED STEEL, 4" DIA.	FOOT	1653
CONDUIT ATTACHED TO STRUCTURE, 2" DIA., PVC COATED GALVANIZED STEEL	FOOT	618
JUNCTION BOX, STAINLESS STEEL, ATTACHED TO STRUCTURE, 12" X 12" X 6"	EACH	8
COMMUNICATIONS VAULT	EACH	1
UNIT DUCT, 600V, 2-1C NO.4, 1/C NO.6 GROUND, (XLP-TYPE USE), 1" DIA. POLYETHYLENE	FOOT	508
UNIT DUCT, 600V, 3-1C NO.4, 1/C NO.6 GROUND, (XLP-TYPE USE), 1 1/4" DIA. POLYETHYLENE	FOOT	3241
ELECTRIC CABLE IN CONDUIT, 600V (XLP-TYPE USE) 1/C NO. 6	FOOT	640
ELECTRIC CABLE IN CONDUIT, 600V (XLP-TYPE USE) 1/C NO. 4	FOOT	2560
ELECTRIC CABLE IN CONDUIT, 600V (XLP-TYPE USE) 1/C NO. 3/0	FOOT	120
LUMINAIRE, SODIUM VAPOR, HORIZONTAL MOUNT, 400 WATT	EACH	13
LUMINAIRE, SODIUM VAPOR, HIGH MAST, HORIZONTAL MOUNT, 750 WATT	EACH	24
LIGHTING CONTROLLER, RADIO CONTROL, DUPLEX CONSOLE TYPE, WITH SCADA	EACH	1
LIGHT POLE, ALUMINUM, 47.5 FT. M.H., 12 FT. MAST ARM	EACH	13
LIGHT TOWER, 90 FT. MOUNTING HEIGHT, LUMINAIRE MT. - 6	EACH	4
LIGHT POLE FOUNDATION, 24" DIAMETER	FOOT	108
LIGHT TOWER FOUNDATION, 48" DIAMETER	FOOT	64
BREAKAWAY DEVICE, TRANSFORMER BASE, 15 INCH BOLT CIRCLE	EACH	13
FIBER OPTIC CABLE ON MESSENGER, NO. 62.5/125, 4F	FOOT	1181
ELECTRIC CABLE IN CONDUIT, TRACER, NO. 14 1C	FOOT	270
CLOSED CIRCUIT TELEVISION DOME CAMERA HIGH MAST TOWER INSTALLATION	EACH	2
TEMPORARY WOOD POLE, 60 FT., CLASS 4, INSTALL ONLY	EACH	4
CLOSED CIRCUIT TELEVISION DOME CAMERA	EACH	2
LIGHT POLE FOUNDATION, 24" DIAMETER, OFFSET	FOOT	9
FIBER OPTIC INNERDUCT 1 1/4" DIA.	FOOT	400
FIBER OPTIC CABLE, 6 FIBERS, SINGLE MODE	FOOT	401
LUMINAIRE SAFETY CABLE ASSEMBLY	EACH	13
MAINTENANCE OF LIGHTING SYSTEM	CAL MO	5
UNIT DUCT, 600V, 5-1C NO.4, 1/C NO.6 GROUND, (XLP-TYPE USE), 1 1/2" DIA. POLYETHYLENE	FOOT	1385
CLOSED CIRCUIT TELEVISION CABINET	EACH	2
REMOVE TEMPORARY WOOD POLE	EACH	4
CLOSED CIRCUIT TELEVISION EQUIPMENT, FIBER OPTIC DISTRIBUTION	EACH	4
MODIFICATION OF EXISTING VIDEO DISTRIBUTION SYSTEM	L SUM	1
CCTV VIDEO DECODER	EACH	4

**PANEL SCHEDULE AND LOAD TABULATION LIGHTING CONTROLLER UF 240/480VAC, 1-PHASE, 3-WIRE**

MAIN BREAKER: 175A



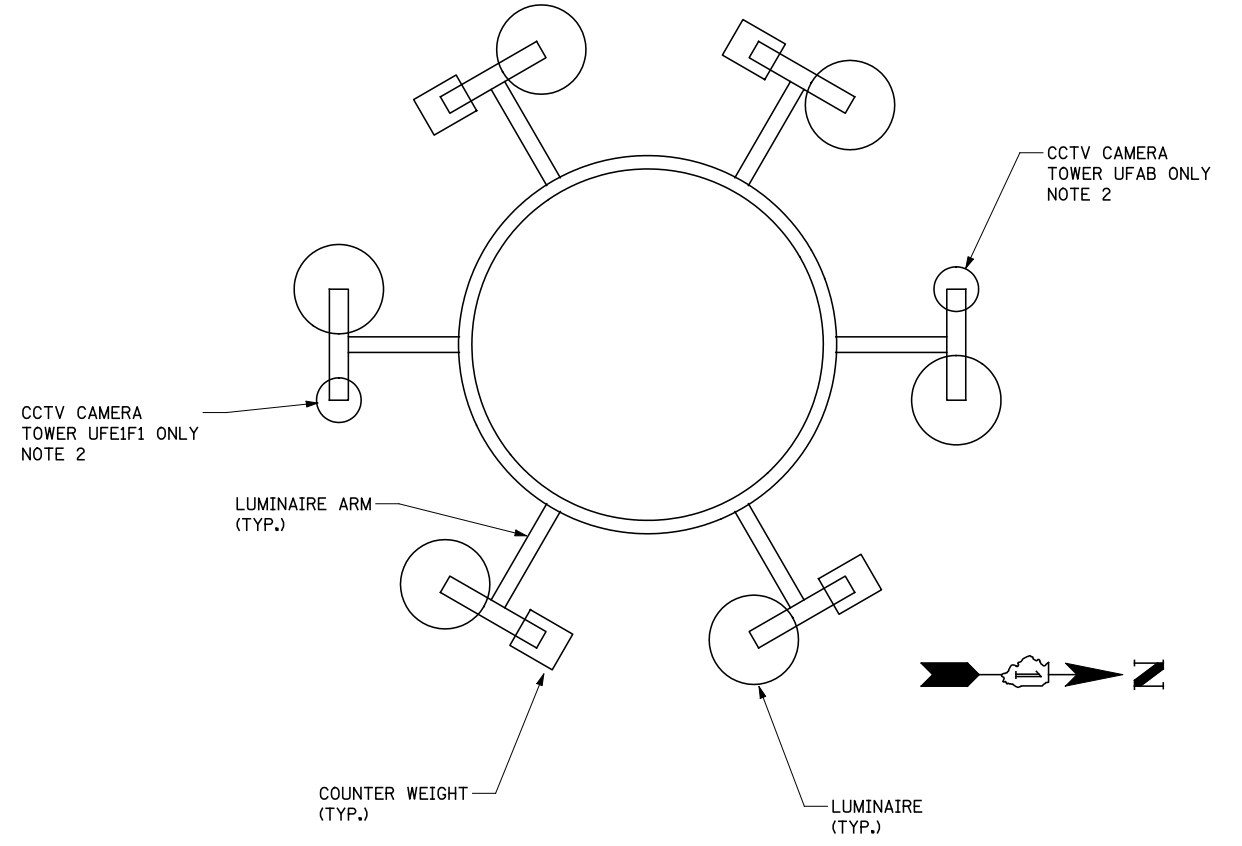













CIRCUIT	BREAKER TRIP AMPS	AMPS	
		RED	BLACK
A	70-1P	10.32	
B	70-1P		10.32
C	70-1P	20.64	
D	70-1P		20.64
E	70-1P	12.15	
F	70-1P		13.98
M	70-1P	5.49	
N	70-1P		7.32
O	70-1P	7.32	
P	70-1P		5.49
<b>TOTAL</b>		<b>56.84</b>	



**LIGHT TOWER LUMINAIRE RING DETAIL (TYP.)**  
NOT TO SCALE

- NOTES:**
- FOR SYMBOL LIST AND GENERAL ELECTRICAL NOTES, SEE SHEET LT-01.
  - A COUNTER WEIGHT SHALL BE PROVIDED ON THE ARM WHERE A CCTV CAMERA IS NOT SHOWN.

SYMBOL LIST

-  EXISTING LIGHTING CONTROLLER
-  NEW LIGHTING CONTROLLET
-  EXISTING LIGHT POLE TO REMAIN
-  EXISTING ITEM TO BE REMOVED
-  EXISTING LIGHT POLE TO BE REMOVED AND SALVAGED
-  LIGHT POLE (INSTALL ONLY) ON NEW FOUNDATION
-  TEMPORARY 750W HPS LUMINAIRE AND WOOD POLE, 90 FT., WITH 15 FT. MAST ARM
-  NEW 400W HPS LUMINAIRE, POLE AND FOUNDATION, SINGLE ARM, GROUND MOUNTED
-  NEW 400W HPS LUMINAIRE AND POLE SINGLE ARM, RETAINING WALL OR PARAPET MOUNTED
-  NEW UNDERPASS LIGHT FIXTURE
-  LOW DUTY LIGHTING HANDHOLE
-  HIGH DUTY LIGHTING HANDHOLE
-  GROUND ROD
-  SERVICE TRANSFORMER ON UTILITY (COMED) POLE
-  TEMPORARY WOOD POLE, 40 FT., CLASS 4
- UNIT DUCT. NO. AND SIZE OF WIRES AS NOTED ON PLANS
- EXISTING WIRING
- - - - WIRING IN CONDUIT ATTACHED TO STRUCTURE
- WIRING IN CONDUIT EMBEDDED IN STRUCTURE
- AC--- AERIAL CABLE, 4-1/C NO. 2, WITH MESSENGER WIRE, UNLESS OTHERWISE NOTED
- ===== UNDERGROUND CONDUIT, 4" DIA., TYPE AS NOTED.
-  NEW LIGHTING JUNCTION BOX. TYPE AND SIZE AS NOTED
-  WIRING/CONDUIT TAG

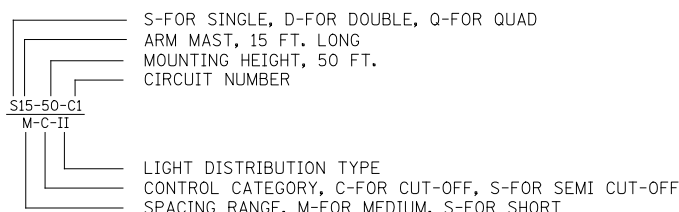









ABBREVIATIONS

- A AMPS
- DIA DIAMETER
- C CONDUIT
- GND GROUND
- FT FEET
- HPS HIGH PRESSURE SODIUM
- LT LEFT
- MC MEDIUM CUTOFF
- P PUSHED
- PC PHOTO CONTROL
- PH PHASE
- PVC POLYVINYL CHLORIDE
- RGS RIGID GALVANIZED STEEL
- RT RIGHT
- STA STATION
- UNO UNLESS NOTED OTHERWISE
- V VOLTS
- W WATTS

GENERAL NOTES

1. CONTRACTOR SHALL MAINTAIN EXISTING TO REMAIN AND TEMPORARY LIGHTING SYSTEM THROUGHOUT THE PROJECT LIMITS AND ADJACENT AREAS UNTIL NEW LIGHTING SYSTEM IS OPERATIONAL.
2. ALL UNIT DUCT SHALL BE PLOWED-IN UNLESS SPECIFICALLY NOTED ON THE PLANS TO BE INSTALLED IN (A)-TRENCH, (B)-4" SCH. 40 PVC DUCT, OR (C)-4" UNDERGROUND CONDUIT OR CASING TAGGED AS APPLICABLE.
3. PRIOR TO INSTALLATION OF NEW UNIT DUCT, CONDUITS, JUNCTION BOXES, LIGHT STANDARD FOUNDATION AND APPURTENANCES, THE CONTRACTOR SHALL DETERMINE THE EXACT LOCATION OF EXISTING CONDUITS, CABLES AND UNDERGROUND UTILITIES. THE CONTRACTOR SHALL CALL J.U.L.I.E. TO AID IN THIS TASK.
4. THE CONTRACTOR SHALL VERIFY ALL DATA SHOWN ON THE CONTRACT PLANS AND REFERENCE DRAWINGS WHICH WOULD AFFECT HIS WORK UNDER THIS CONTRACT AND THE OPERATION OF THE EXISTING ROADWAY LIGHTING AND SIGN LIGHTING SYSTEMS.
5. ALL NEW UNIT DUCT, CONDUIT, JUNCTION BOXES AND APPURTENANCES ARE ILLUSTRATED DIAGRAMMATICALLY. THE ACTUAL LOCATION IN THE FIELD SHALL MEET WITH THE APPROVAL OF THE ENGINEER.
6. THE ELECTRICAL MATERIALS SHALL BE NEW AND OF THE TYPE AND KINDS APPROVED BY THE FOLLOWING ORGANIZATIONS:  
  
 NATIONAL ELECTRICAL MANUFACTURERS ASSOCIATION  
 INSTITUTE OF ELECTRICAL AND ELECTRONIC ENGINEERS  
 ILLUMINATING ENGINEERING SOCIETY OF NORTH AMERICA  
 AMERICAN ASSOC. OF STATE HWYWAY AND TRANSPORTATION OFFICIALS  
 U.S. DEPARTMENT OF TRANSPORTATION  
 UNDERWRITERS LABORATORIES  
 AMERICAN NATIONAL STANDARD INSTITUTE  
 INSULATED CABLE ENGINEERS ASSOCIATION
7. CONDUIT AND UNIT DUCT SHALL BE POSITIONED IN THE FIELD TO AVOID UTILITY INTERFERENCE - CONTRACTOR TO VERIFY LOCATION.
8. ALL PITS USED FOR INSTALLED PUSHED (JACKED) STEEL CASING UNDER EXISTING ROADWAYS SHALL BE LOCATED FIVE (5) FEET MINIMUM CLEARANCE FROM THE EDGE OF THE SHOULDER. LOCATIONS OF THE CONDUIT CROSSING SHOWN ARE APPROXIMATE AND MAY BE SHIFTED AS NECESSARY TO MEET THE MINIMUM CLEARANCE REQUIREMENTS. THE PITS MUST BE ADEQUATELY GUARDED TO PROTECT THE MOTORISTS. THE CONTRACTOR MUST SUBMIT PLANS FOR THE LOCATION AND SIZE OF THE PITS AND MAINTENANCE AND PROTECTION OF TRAFFIC AT THE SITE FOR THE APPROVAL OF THE ENGINEER.
9. LUMINAIRES MUST BE INSTALLED ON LIGHT STANDARDS WITHIN A MAXIMUM OF 48 HOURS AFTER LIGHT STANDARD IS ERECTED.
10. WHERE THE PROPOSED UNDERPASS LUMINAIRES ARE TO BE INSTALLED, THE LUMINAIRES AND RELATED WIRING SHALL BE INSTALLED AS SHOWN ON SHEET LT-20.
11. WHERE THE PROPOSED JUNCTION BOXES ARE TO BE INSTALLED, THE EMBEDDED JUNCTION BOXES SHALL BE INSTALLED AS SHOWN ON IDOT DISTRICT 1 DETAIL BE703.
12. TEMPORARY LIGHTING SHALL REMAIN IN SERVICE UNTIL THE PERMANENT LIGHTING SYSTEM IS IN OPERATION. THE CONTRACTOR MUST MAINTAIN SAFE EQUIPMENT AND WORKING CLEARANCES FROM THE EXISTING COMED OVERHEAD ELECTRIC LINES.

CABLEDUCT SCHEDULE

-  UNIT DUCT, WITH 4-1/C NO. 2 AND 1/C NO. 4 GROUND, 600V (XLP-TYPE USE), 2" DIA. CNC IN UNDERGROUND CONDUIT, PVC, 4" DIA.
-  ELECTRIC CABLE, 600V (XLP-TYPE USE) (4)1/C NO. 10 IN CONDUIT ATTACHED TO STRUCTURE, 3/4" DIA., PVC COATED GALVANIZED STEEL
-  UNIT DUCT, WITH 4-1/C NO. 2 AND 1/C NO. 4 GROUND, 600V (XLP-TYPE USE), 2" DIA. CNC
-  UNIT DUCT, WITH 4-1/C NO. 2 AND 1/C NO. 4 GROUND, 600V (XLP-TYPE USE), 2" DIA. CNC IN UNDERGROUND CONDUIT, PVC COATED GALVANIZED STEEL, 4" DIA.
-  UNIT DUCT, WITH 4-1/C NO. 2 AND 1/C NO. 4 GROUND, 600V (XLP-TYPE USE), 2" DIA. CNC IN CONDUIT EMBEDDED IN STRUCTURE, 4" DIA., PVC
-  UNIT DUCT, WITH 2-1/C NO. 2 AND 1/C NO. 4 GROUND, 600V (XLP-TYPE USE), 2" DIA. CNC
-  ELECTRIC CABLE, 600V (XLP-TYPE USE) (3)1/C NO. 3/0 IN UNDERGROUND CONDUIT, PVC, 3" DIA.
-  ELECTRIC CABLE, 600V (XLP-TYPE USE) (3)1/C NO. 10 IN , 3/4" LIQUIDTIGHT FLEXIBLE METALLIC CONDUIT
-  ELECTRIC CABLE, 600V (XLP-TYPE USE) (4)1/C NO. 2, 1/C NO. 4 IN CONDUIT ATTACHED TO STRUCTURE, 2" DIA., PVC COATED GALVANIZED STEEL

FILE NAME = #FILEL#	USER NAME = #USER#	DESIGNED <i>MCP</i>	REVISED -	<b>STATE OF ILLINOIS DEPARTMENT OF TRANSPORTATION</b>	<b>TOLLWAY ELECTRICAL SYMBOLS, ABBREVIATIONS AND GENERAL NOTES</b>	F.A.P. RTE.	SECTION	COUNTY	TOTAL SHEETS	SHEET NO.	
		DRAWN <i>MLB</i>	REVISED -			338	(112 & 113) WRS-5	DUPAGE	963	561	
		CHECKED <i>MCP</i>	REVISED -			<b>LT-06</b> CONTRACT NO. 60131					
		DATE <i>10/15/2012</i>	REVISED -			ILLINOIS FED. AID PROJECT					
				SCALE: AS SHOWN		SHEET NO. 1 OF 1 SHEETS		STA.		TO STA.	

- NOTES:**
- COORDINATE REMOVAL OF EXISTING UNDERPASS LIGHTING WITH THE REMOVAL OF THE STRUCTURE.
  - EXISTING LIGHTING CONTROLLER SHALL REMAIN ACTIVE UNTIL ALL LIGHTING IS TRANSFERRED TO THE NEW CONTROLLER. COORDINATE THE REMOVAL OF EXISTING CONTROLLER WITH ALL TRADES.
  - FOR SYMBOL LIST AND GENERAL ELECTRICAL NOTES, SEE SHEET LT-6.
  - NEW TOLLWAY LIGHTING CONTROLLER SHALL BE INSTALLED AND TEMPORARY AERIAL CONNECTIONS SHALL BE PROVIDED TO ALL TEMPORARY AND EXISTING TO REMAIN LIGHTING UNITS. AERIAL CABLES SHALL BE RUN DOWN THE TEMPORARY WOOD POLE UNDERGROUND AND THROUGH THE CONDUIT ELBOWS IN THE CONTROLLER FOUNDATION TO THE PROPER CIRCUIT BREAKERS. AERIAL CONNECTIONS SHALL BE REMOVED AFTER ALL NEW LIGHTING UNITS AND WIRING BECOME FUNCTIONAL.
  - FOR COMED SERVICE TO NEW LIGHTING CONTROLLER, SEE DETAIL ON SHEET LT-19.

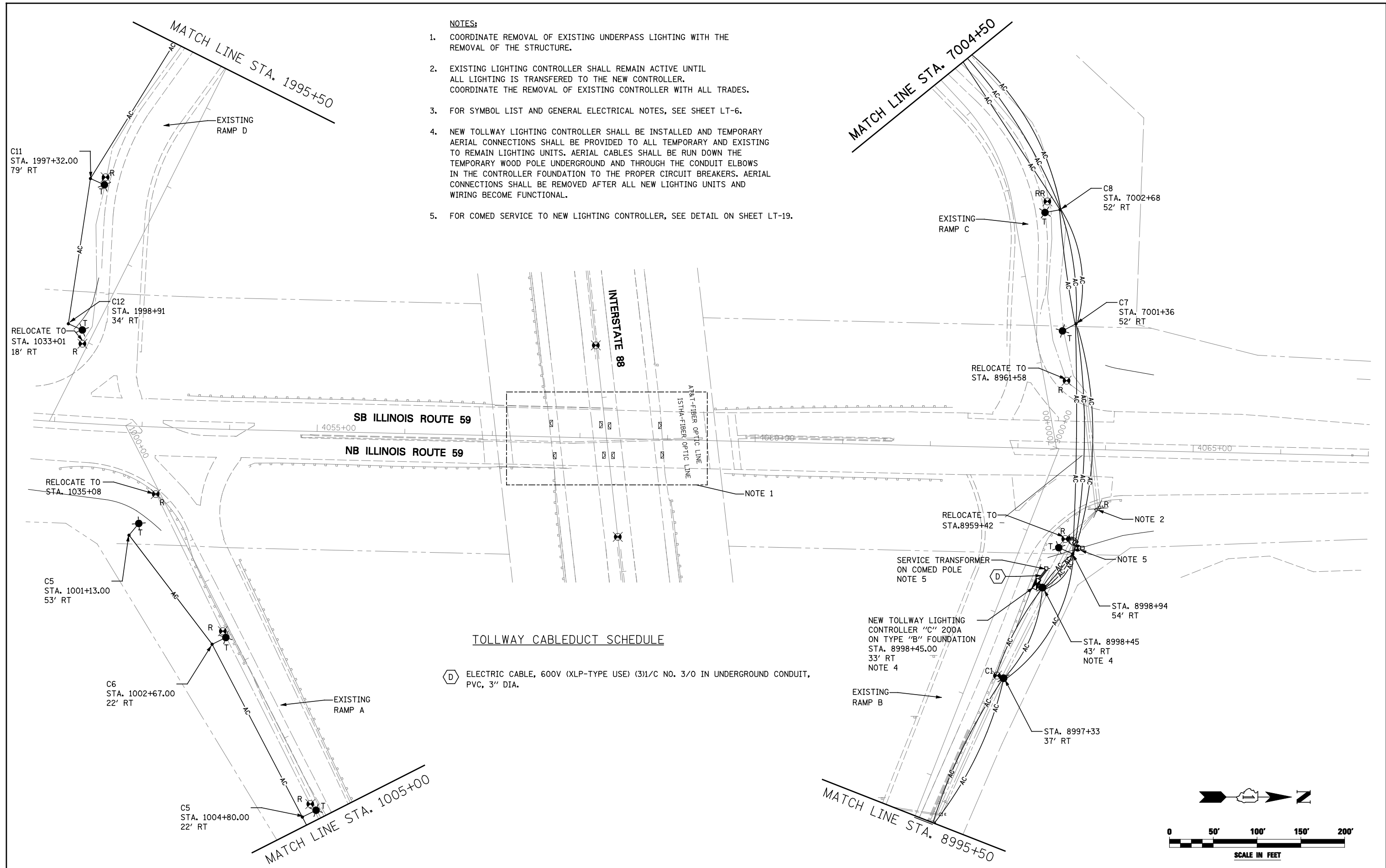

**TOLLWAY CABLEDUCT SCHEDULE**

**D** ELECTRIC CABLE, 600V (XLP-TYPE USE) (3)1/C NO. 3/0 IN UNDERGROUND CONDUIT, PVC, 3" DIA.

FILE NAME = #FILE#	USER NAME = #USER#	DESIGNED MCP	REVISED -
		DRAWN MLB	REVISED -
		CHECKED MCP	REVISED -
		DATE 10/15/2012	REVISED -

**STATE OF ILLINOIS  
DEPARTMENT OF TRANSPORTATION**

<b>TOLLWAY DEMOLITION AND TEMPORARY LIGHTING PLAN</b>			
<b>ILLINOIS ROUTE 59 AT INTERSTATE 88</b>			
SCALE: AS SHOWN	SHEET NO. 1 OF 5 SHEETS	STA. 4051+75	TO STA. 4067+00

F.A.P. RTE.	SECTION	COUNTY	TOTAL SHEETS	SHEET NO.
338	(112 & 113) WRS-5	DUPAGE	963	562
<b>LT-07</b>			CONTRACT NO. 60I31	
ILLINOIS FED. AID PROJECT				

**NOTES:**

1. FOR SYMBOL LIST AND GENERAL ELECTRICAL NOTES, SEE SHEET LT-6.
2. EXISTING POLE AND LUMINAIRE SHALL BE REMOVED DURING CONSTRUCTION AND SHALL BE REINSTALLED ON THE SAME FOUNDATION AT THE COMPLETION OF CONSTRUCTION.

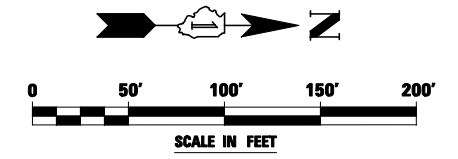
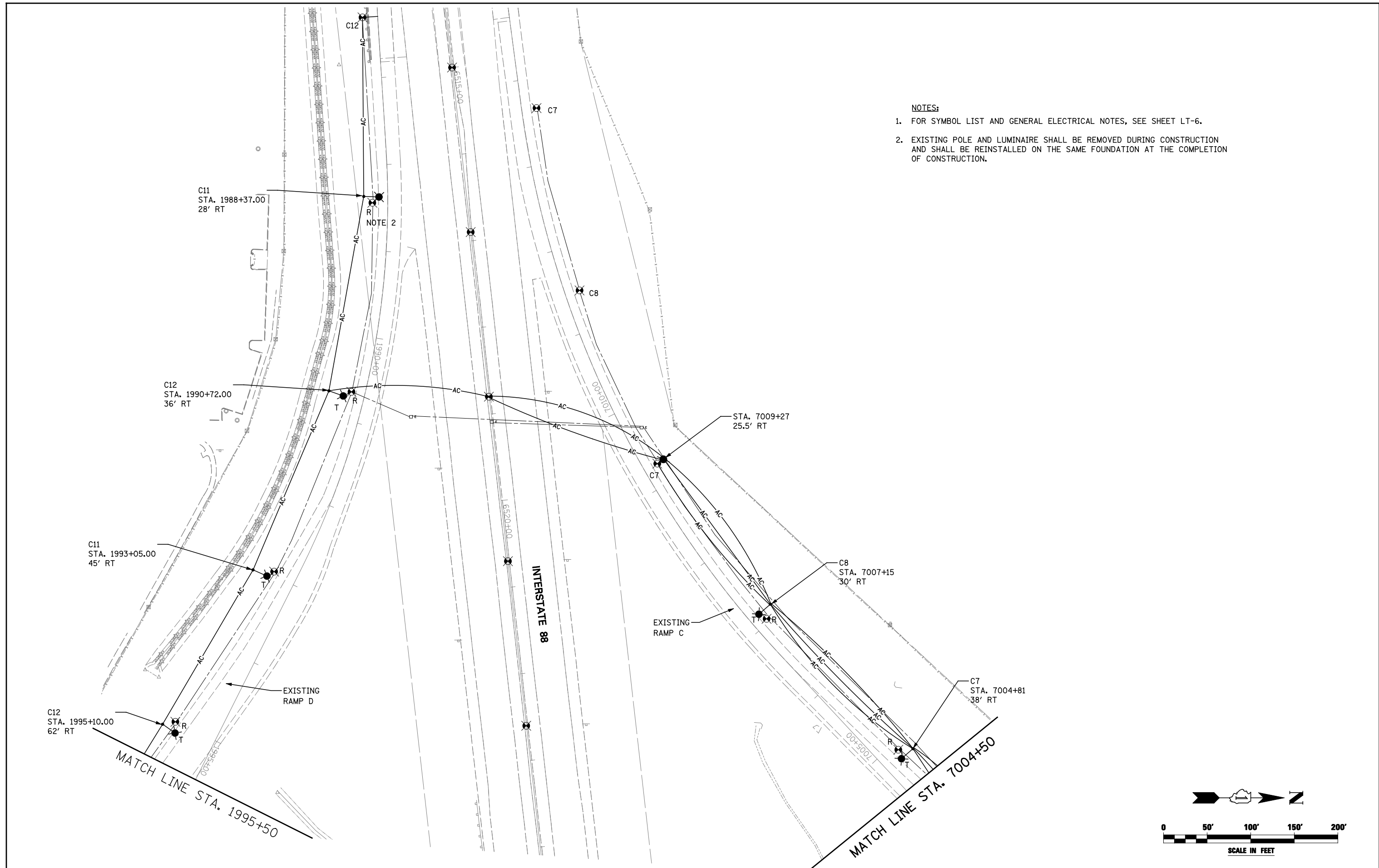

FILE NAME = #FILEL#	USER NAME = #USER#	DESIGNED MCP	REVISED -
		DRAWN MLB	REVISED -
		CHECKED MCP	REVISED -
		DATE 10/15/2012	REVISED -

**STATE OF ILLINOIS  
DEPARTMENT OF TRANSPORTATION**

**TOLLWAY DEMOLITION AND TEMPORARY LIGHTING PLAN  
ILLINOIS ROUTE 59 AT INTERSTATE 88 - RAMPS C & D**

F.A.P. RTE.	SECTION	COUNTY	TOTAL SHEETS	SHEET NO.
338	(112 & 113) WRS-5	DUPAGE	963	563
<b>LT-08</b>			CONTRACT NO. 60I31	
ILLINOIS FED. AID PROJECT				

SCALE: AS SHOWN | SHEET NO. 2 OF 5 SHEETS | STA. TO STA.

MATCH LINE STA. 1005+00

MATCH LINE STA. 8995+50

C6  
STA. 1007+07.00  
22' RT

C5  
STA. 1009+25.00  
22' RT

C6  
STA. 1011+27.00  
22' RT

C5  
STA. 1013+43.00  
22' RT

INTERSTATE 88

**NOTES:**

1. FOR SYMBOL LIST AND GENERAL ELECTRICAL NOTES, SEE SHEET LT-06.

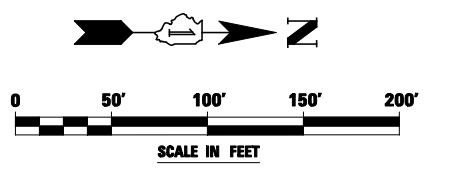

MATCH LINE STA. 6541+00

FILE NAME = *FILEL*	USER NAME = *USER*	DESIGNED <i>MCP</i>	REVISED -
		DRAWN <i>MLB</i>	REVISED -
		CHECKED <i>MCP</i>	REVISED -
		DATE <i>10/15/2012</i>	REVISED -

**STATE OF ILLINOIS  
DEPARTMENT OF TRANSPORTATION**

**TOLLWAY DEMOLITION AND TEMPORARY LIGHTING PLAN  
ILLINOIS ROUTE 59 AT INTERSTATE 88 - RAMPS A & B**

SCALE: AS SHOWN | SHEET NO. 3 OF 5 SHEETS | STA. TO STA.

F.A.P. RTE.	SECTION	COUNTY	TOTAL SHEETS	SHEET NO.
338	(112 & 113) WRS-5	DUPAGE	963	564
<b>LT-09</b>			CONTRACT NO. 60I31	
ILLINOIS FED. AID PROJECT				



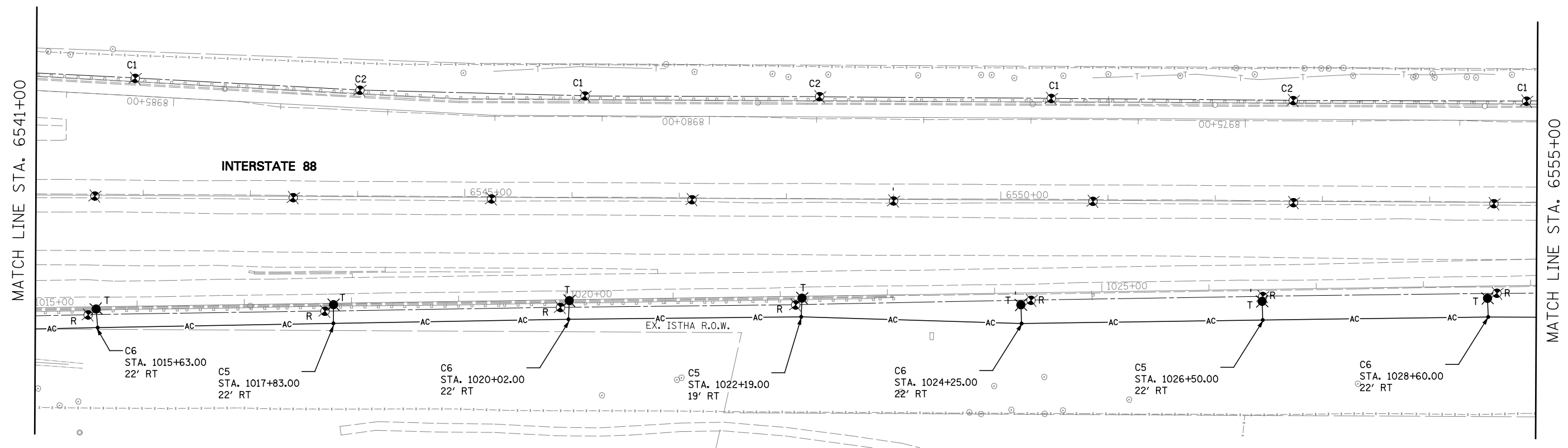

- NOTES:**
- FOR SYMBOL LIST AND GENERAL ELECTRICAL NOTES, SEE SHEET LT-06.

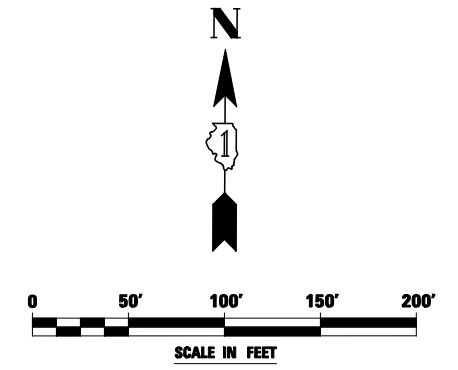

FILE NAME = #FILE#	USER NAME = #USER#	DESIGNED <i>MCP</i>	REVISED -	<b>STATE OF ILLINOIS DEPARTMENT OF TRANSPORTATION</b>	<b>TOLLWAY DEMOLITION AND TEMPORARY LIGHTING PLAN ILLINOIS ROUTE 59 AT INTERSTATE 88 - RAMPS A &amp; B</b>	F.A.P. RTE.	SECTION	COUNTY	TOTAL SHEETS	SHEET NO.	
		DRAWN <i>MLB</i>	REVISED -			338	(112 & 113) WRS-5	DUPAGE	963	565	
		CHECKED <i>MCP</i>	REVISED -			<b>LT-10</b>		CONTRACT NO. 60I31			
		DATE <i>10/15/2012</i>	REVISED -			SCALE: AS SHOWN   SHEET NO. 4 OF 5 SHEETS   STA. TO STA.		ILLINOIS FED. AID PROJECT			

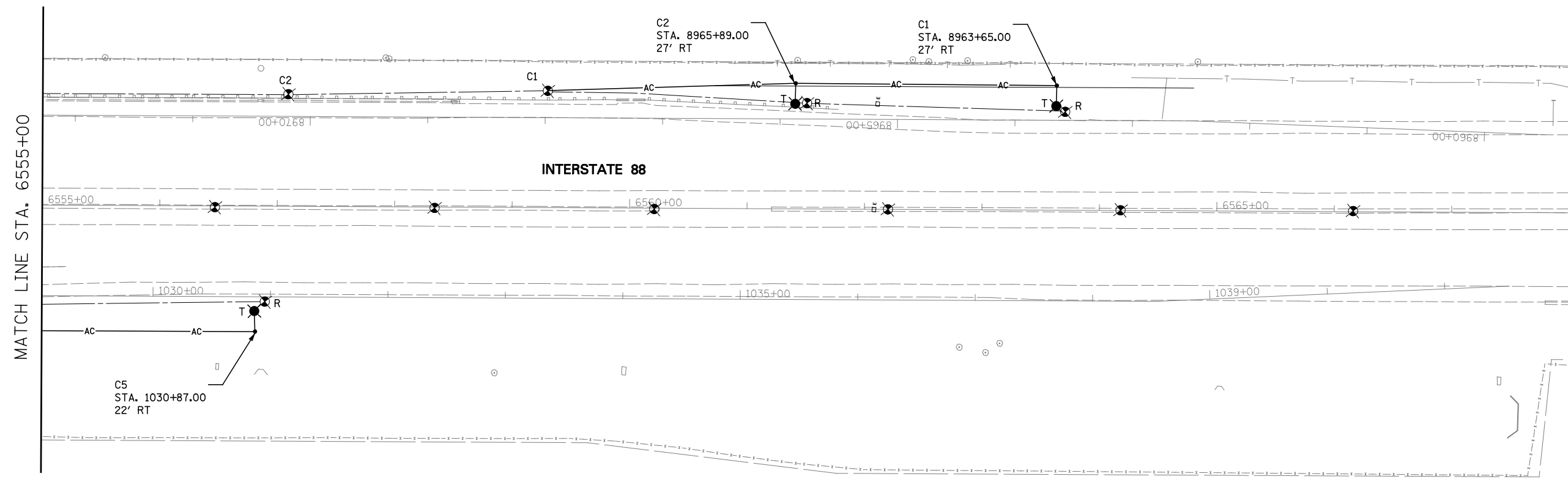

**NOTES:**  
 1. FOR SYMBOL LIST AND GENERAL ELECTRICAL NOTES, SEE SHEET LT-06.

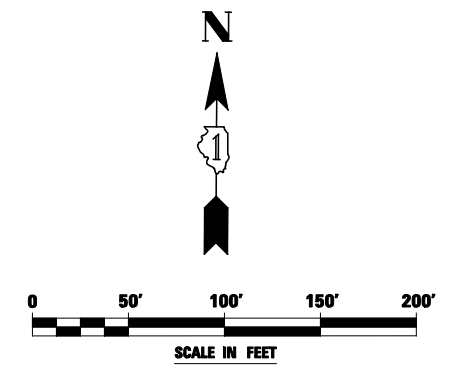

FILE NAME = #FILEL#	USER NAME = #USER#	DESIGNED <i>MCP</i>	REVISED -	<b>STATE OF ILLINOIS DEPARTMENT OF TRANSPORTATION</b>	<b>TOLLWAY DEMOLITION AND TEMPORARY LIGHTING PLAN ILLINOIS ROUTE 59 AT INTERSTATE 88 - RAMPS A &amp; B</b>	F.A.P. RTE.	SECTION	COUNTY	TOTAL SHEETS	SHEET NO.	
	PLOT SCALE = #SCALE#	DRAWN <i>MLB</i>	REVISED -			338	(112 & 113) WRS-5	DUPAGE	963	566	
	PLOT DATE = #DATE#	CHECKED <i>MCP</i>	REVISED -			<b>LT-11</b>		CONTRACT NO. 60I31			
		DATE <i>10/15/2012</i>	REVISED -			SCALE: AS SHOWN   SHEET NO. 5 OF 5 SHEETS   STA. TO STA.		ILLINOIS FED. AID PROJECT			

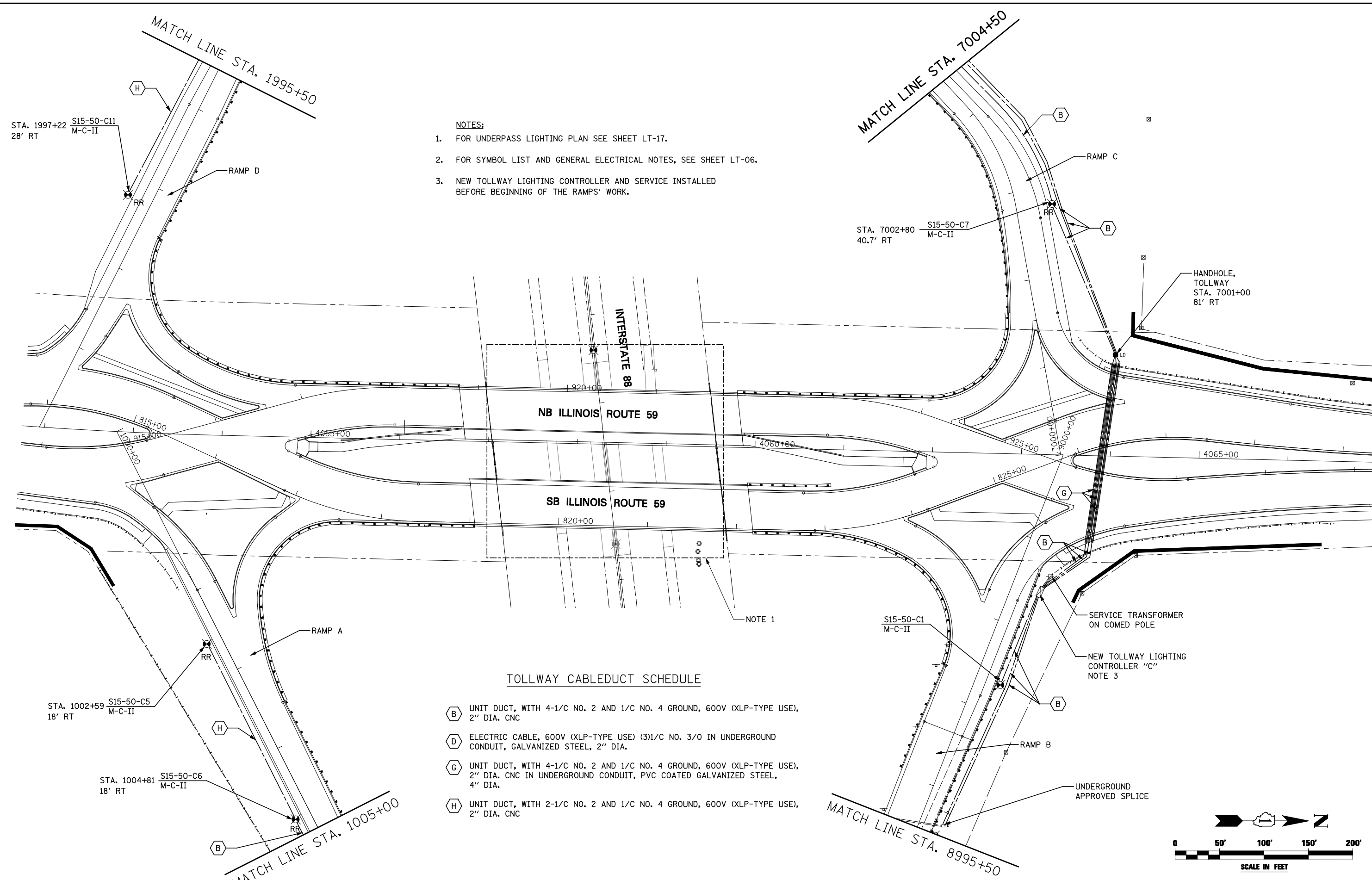

- NOTES:**
1. FOR UNDERPASS LIGHTING PLAN SEE SHEET LT-17.
  2. FOR SYMBOL LIST AND GENERAL ELECTRICAL NOTES, SEE SHEET LT-06.
  3. NEW TOLLWAY LIGHTING CONTROLLER AND SERVICE INSTALLED BEFORE BEGINNING OF THE RAMPS' WORK.

**TOLLWAY CABLEDUCT SCHEDULE**

- B** UNIT DUCT, WITH 4-1/2 NO. 2 AND 1/2 NO. 4 GROUND, 600V (XLP-TYPE USE), 2" DIA. CNC
- D** ELECTRIC CABLE, 600V (XLP-TYPE USE) (3)1/2 NO. 3/0 IN UNDERGROUND CONDUIT, GALVANIZED STEEL, 2" DIA.
- G** UNIT DUCT, WITH 4-1/2 NO. 2 AND 1/2 NO. 4 GROUND, 600V (XLP-TYPE USE), 2" DIA. CNC IN UNDERGROUND CONDUIT, PVC COATED GALVANIZED STEEL, 4" DIA.
- H** UNIT DUCT, WITH 2-1/2 NO. 2 AND 1/2 NO. 4 GROUND, 600V (XLP-TYPE USE), 2" DIA. CNC

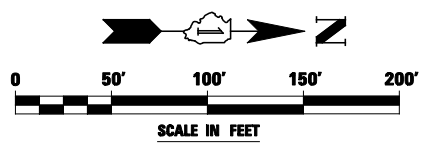

FILE NAME =	USER NAME = #USER#	DESIGNED MCP	REVISED -
#FILE#		DRAWN MLB	REVISED -
	PLOT SCALE = #SCALE#	CHECKED MCP	REVISED -
	PLOT DATE = #DATE#	DATE 10/15/2012	REVISED -

**STATE OF ILLINOIS  
DEPARTMENT OF TRANSPORTATION**

**TOLLWAY LIGHTING PLAN - ILLINOIS ROUTE 59  
AT INTERSTATE 88**

SCALE: AS SHOWN SHEET NO. 1 OF 6 SHEETS STA. 4051+75 TO STA. 4067+00

F.A.P. RTE.	SECTION	COUNTY	TOTAL SHEETS	SHEET NO.
338	(112 & 113) WRS-5	DUPAGE	963	567
<b>LT-12</b>		CONTRACT NO. 60131		
ILLINOIS FED. AID PROJECT				

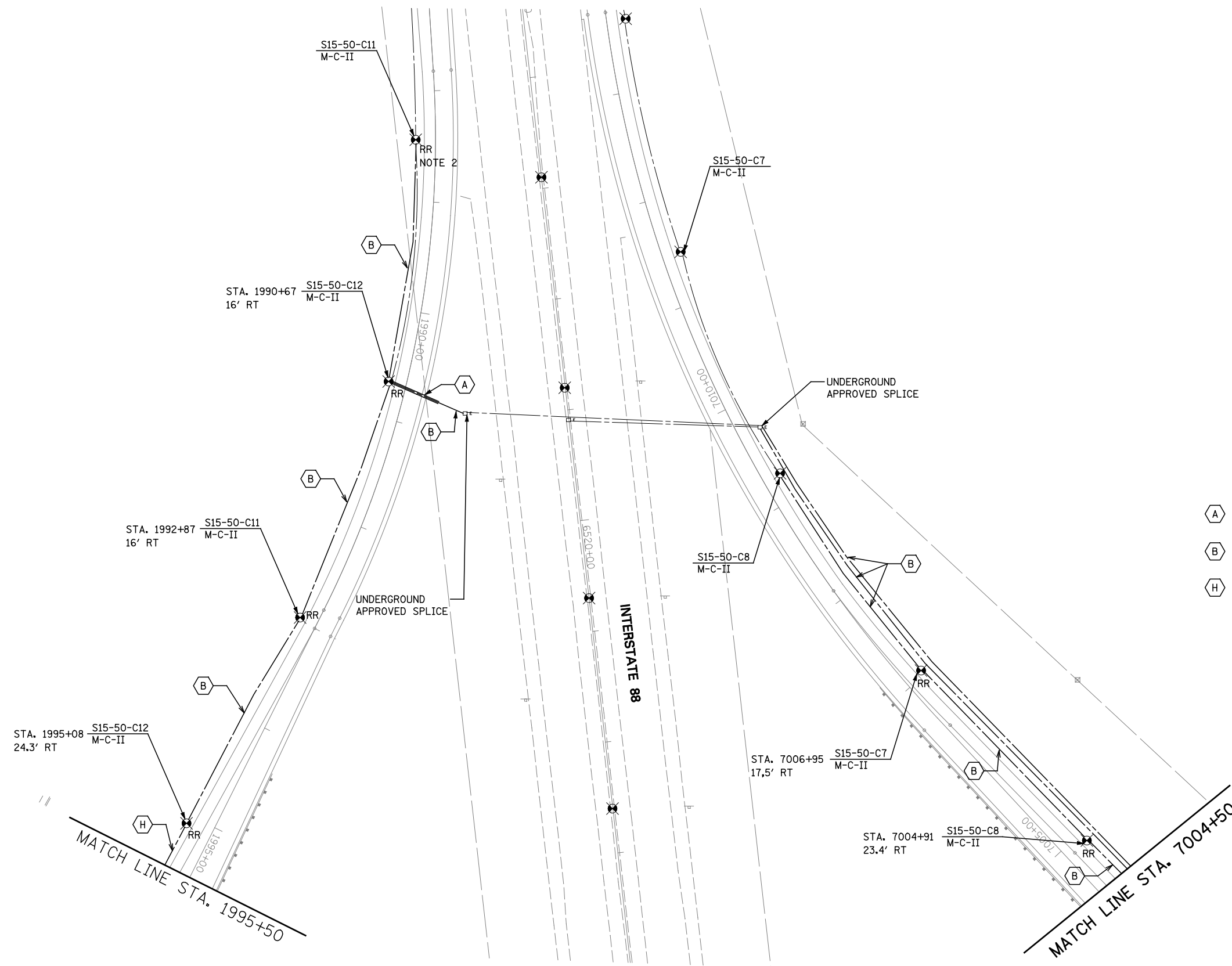

- NOTES:**
- FOR SYMBOL LIST AND GENERAL ELECTRICAL NOTES, SEE SHEET LT-06.
  - LIGHTING UNIT SHALL BE REINSTALLED ON EXISTING LIGHT POLE FOUNDATION.

**TOLLWAY CABLEDUCT SCHEDULE**

- (A) UNIT DUCT, WITH 4-1/C NO. 2 AND 1/C NO. 4 GROUND, 600V (XLP-TYPE USE), 2" DIA. CNC IN UNDERGROUND CONDUIT, PVC, 4" DIA.
- (B) UNIT DUCT, WITH 4-1/C NO. 2 AND 1/C NO. 4 GROUND, 600V (XLP-TYPE USE), 2" DIA. CNC
- (H) UNIT DUCT, WITH 2-1/C NO. 2 AND 1/C NO. 4 GROUND, 600V (XLP-TYPE USE), 2" DIA. CNC

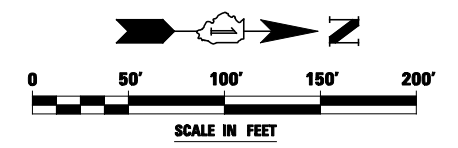

FILE NAME = *FILEL*	USER NAME = *USER*	DESIGNED MCP	REVISED -	<b>STATE OF ILLINOIS DEPARTMENT OF TRANSPORTATION</b>	<b>TOLLWAY LIGHTING PLAN - ILLINOIS ROUTE 59 AT INTERSTATE 88 - RAMPS C &amp; D</b>			F.A.P. RTE.	SECTION	COUNTY	TOTAL SHEETS	SHEET NO.	
		DRAWN MLB	REVISED -		SCALE: AS SHOWN	SHEET NO. 2 OF 6 SHEETS	STA.	TO STA.	338	(112 & 113) WRS-5	DUPAGE	963	568
		CHECKED MCP	REVISED -					<b>LT-13</b>		CONTRACT NO. 60I31			
		DATE 10/15/2012	REVISED -					ILLINOIS FED. AID PROJECT					

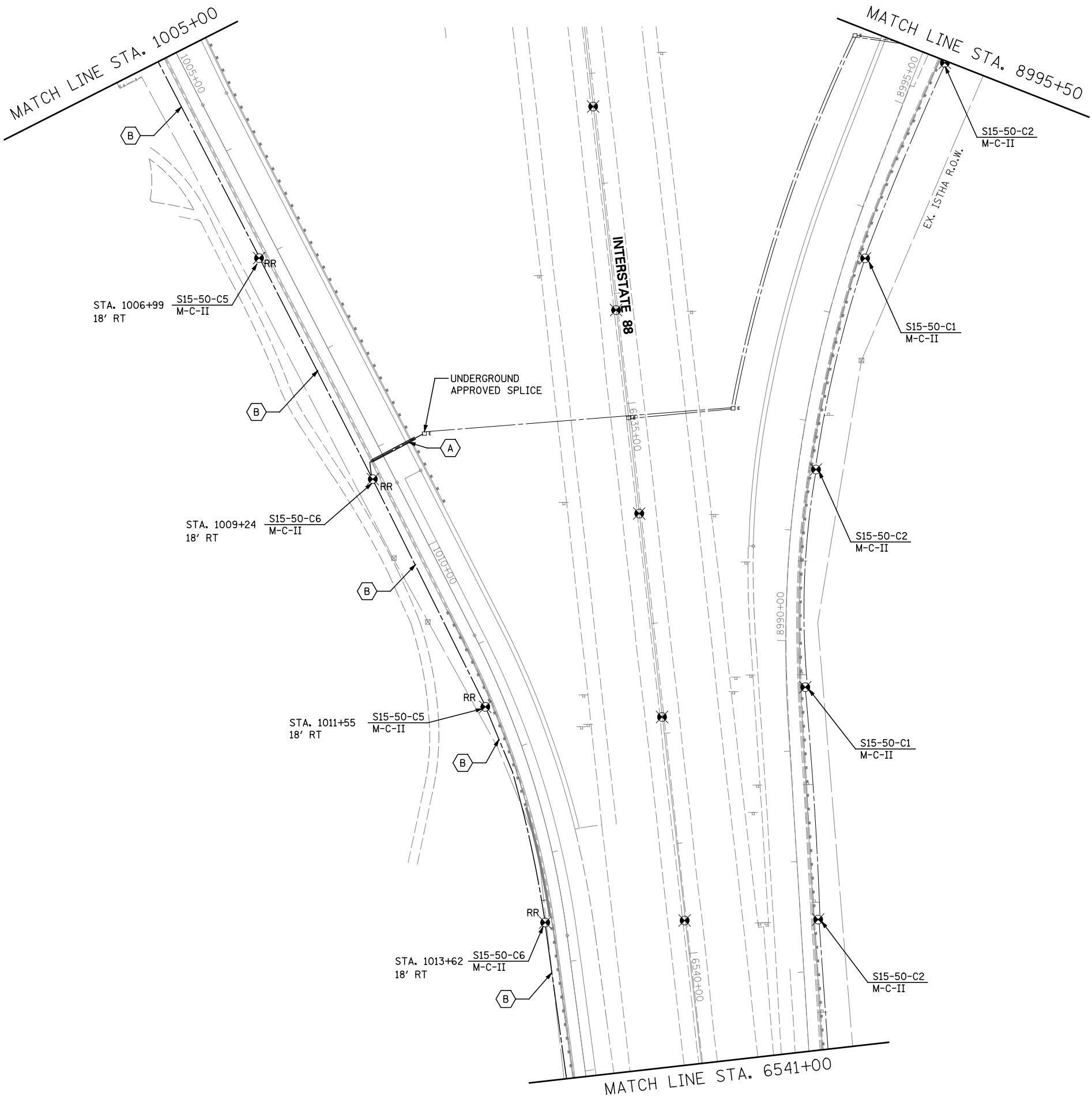

- NOTES:**
1. FOR SYMBOL LIST AND GENERAL ELECTRICAL NOTES, SEE SHEET LT-06.
  2. JUNCTION BOX, STAINLESS STEEL, EMBEDDED IN STRUCTURE, 20" X 12" X 7".

**TOLLWAY CABLEDUCT SCHEDULE**

- (A) UNIT DUCT, WITH 4-1/C NO. 2 AND 1/C NO. 4 GROUND, 600V (XLP-TYPE USE), 2" DIA. CNC IN UNDERGROUND CONDUIT, PVC, 4" DIA
- (B) UNIT DUCT, WITH 4-1/C NO. 2 AND 1/C NO. 4 GROUND, 600V (XLP-TYPE USE), 2" DIA. CNC

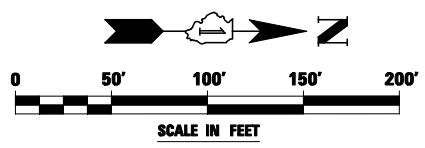

FILE NAME = *FILEL*	USER NAME = *USER*	DESIGNED <i>MCP</i>	REVISED -
		DRAWN <i>MLB</i>	REVISED -
		CHECKED <i>MCP</i>	REVISED -
		DATE <i>10/15/2012</i>	REVISED -

**STATE OF ILLINOIS  
DEPARTMENT OF TRANSPORTATION**

**TOLLWAY LIGHTING PLAN - ILLINOIS ROUTE 59  
AT INTERSTATE 88 - RAMPS A & B**

SCALE: AS SHOWN | SHEET NO. 3 OF 6 SHEETS | STA. TO STA.

F.A.P. RTE.	SECTION	COUNTY	TOTAL SHEETS	SHEET NO.
338	(112 & 113) WRS-5	DUPAGE	963	569
<b>LT-14</b>			CONTRACT NO. 60I31	
ILLINOIS FED. AID PROJECT				

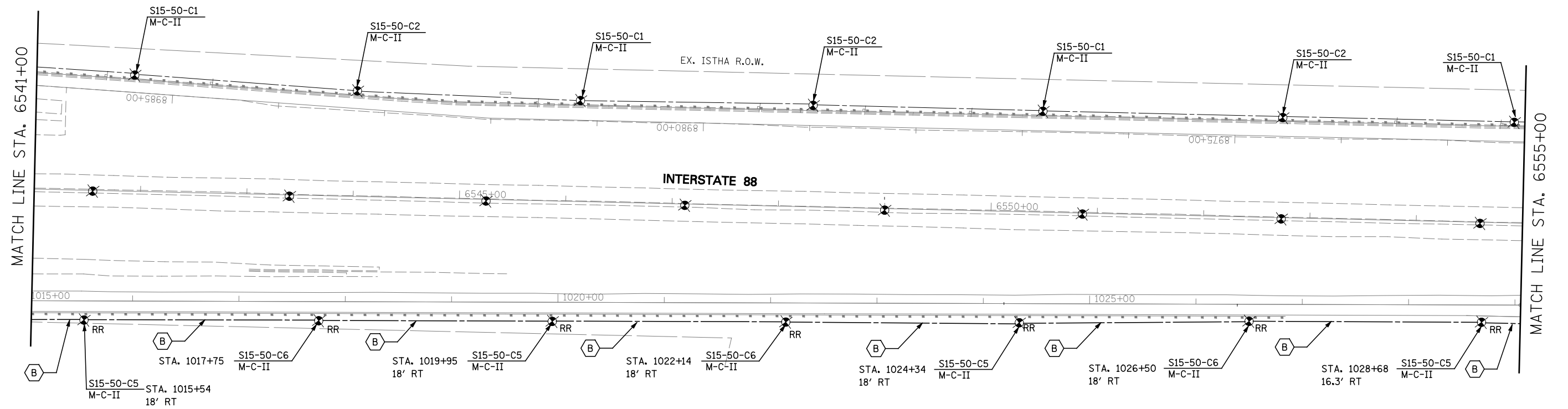

**NOTES:**

1. FOR SYMBOL LIST AND GENERAL ELECTRICAL NOTES, SEE SHEET LT-6.
2. JUNCTION BOX, STAINLESS STEEL, EMBEDDED IN STRUCTURE, 20" X 12" X 7".

**TOLLWAY CABLEDUCT SCHEDULE**

(B) UNIT DUCT, WITH 4-1/2 NO. 2 AND 1/2 NO. 4 GROUND, 600V (XLP-TYPE USE), 2" DIA. CNC

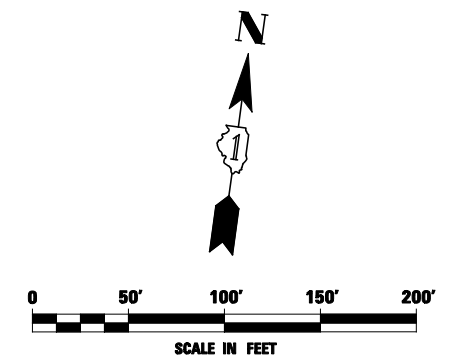

FILE NAME = *FILEL*	USER NAME = *USER*	DESIGNED <i>MCP</i>	REVISED -	<b>STATE OF ILLINOIS DEPARTMENT OF TRANSPORTATION</b>	<b>TOLLWAY LIGHTING PLAN - ILLINOIS ROUTE 59 AT INTERSTATE 88 - RAMPS A &amp; B</b>	F.A.P. RTE.	SECTION	COUNTY	TOTAL SHEETS	SHEET NO.	
		DRAWN <i>MLB</i>	REVISED -			338	(112 & 113) WRS-5	DUPAGE	963	570	
		CHECKED <i>MCP</i>	REVISED -			<b>LT-15</b>		CONTRACT NO. 60I31			
		DATE <i>10/15/2012</i>	REVISED -			SCALE: AS SHOWN SHEET NO. 4 OF 6 SHEETS STA. TO STA.		ILLINOIS FED. AID PROJECT			

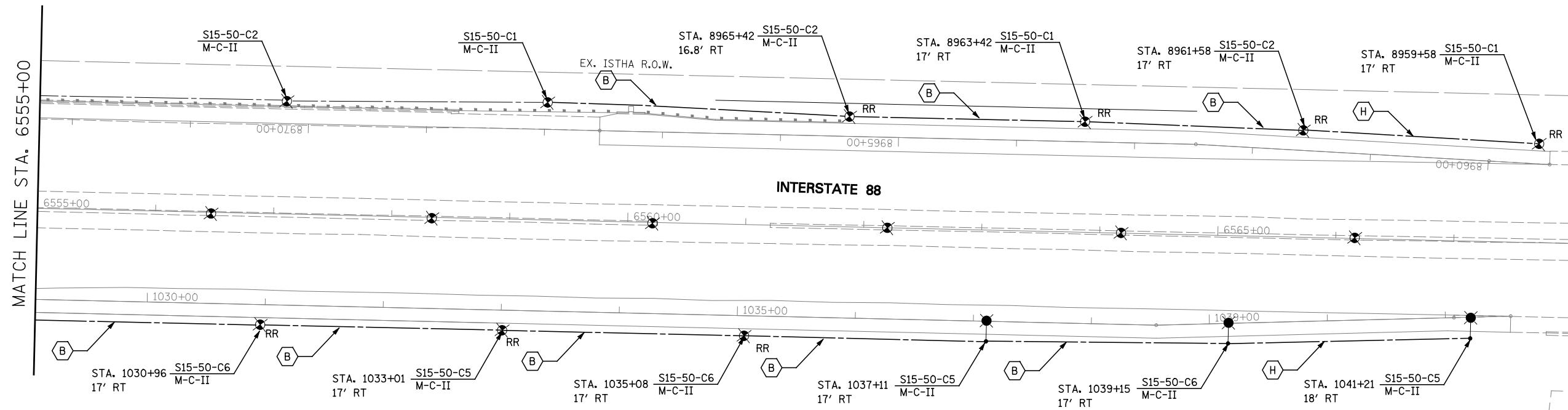

**NOTES:**

1. FOR SYMBOL LIST AND GENERAL ELECTRICAL NOTES, SEE SHEET LT-06.

**TOLLWAY CABLEDUCT SCHEDULE**

- UNIT DUCT, WITH 4-1/2 NO. 2 AND 1/2 NO. 4 GROUND, 600V (XLP-TYPE USE), 2" DIA. CNC
- UNIT DUCT, WITH 2-1/2 NO. 2 AND 1/2 NO. 4 GROUND, 600V (XLP-TYPE USE), 2" DIA. CNC

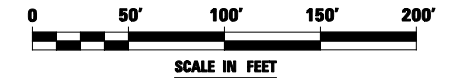

FILE NAME = *FILEL*	USER NAME = *USER*	DESIGNED <i>MCP</i>	REVISED -	<b>STATE OF ILLINOIS DEPARTMENT OF TRANSPORTATION</b>	<b>TOLLWAY LIGHTING PLAN - ILLINOIS ROUTE 59 AT INTERSTATE 88 - RAMPS A &amp; B</b>	F.A.P. RTE.	SECTION	COUNTY	TOTAL SHEETS	SHEET NO.
		DRAWN <i>MLB</i>	REVISED -			338	(112 & 113) WRS-5	DUPAGE	963	571
		CHECKED <i>MCP</i>	REVISED -			<b>LT-16</b>		CONTRACT NO. 60I31		
		DATE <i>10/15/2012</i>	REVISED -			SCALE: AS SHOWN   SHEET NO. 5 OF 6 SHEETS   STA. TO STA.		ILLINOIS FED. AID PROJECT		

**NOTES:**

1. FOR SYMBOL LIST AND GENERAL ELECTRICAL NOTES, SEE SHEET LT-06.
2. JUNCTION BOX, STAINLESS STEEL, EMBEDDED IN STRUCTURE, 20" X 12" X 8".
3. JUNCTION BOX, STAINLESS STEEL, ATTACHED TO STRUCTURE, 12" X 10" X 6".
4. JUNCTION BOX, STAINLESS STEEL, ATTACHED TO STRUCTURE, 6" X 6" X 4".
5. UNDERPASS LIGHTING UNDER SB IL-59 BRIDGE SHALL BE TEMPORARILY FED AS SHOWN. AERIAL CABLE, JUNCTION BOX, CONDUIT AND CONDUCTORS USED FOR TEMPORARY FEED SHALL BE REMOVED WHEN FINAL LIGHTING CONDITIONS WILL BE MET WEST OF THE RESPECTIVE BRIDGE. SEAL THE TEMPORARY OPENINGS IN JUNCTION BOXES NO. 13 AND NO. 14. SEE SHEET LT-19 FOR AERIAL CABLE ATTACHED TO STRUCTURE DETAIL.
6. FOR UNDERPASS LIGHTING INSTALLATION DETAILS, SEE SHEET LT-20.

**JUNCTION BOX LOCATIONS**

NO.	STATION	OFFSET
1	6526+82	0'
2	6526+86	0'
3	6527+01	2' LT
4	6527+02	2' RT
5	6527+26	2' LT
6	6527+27	2' RT
7	6527+43	0'
8	6527+47	0'
9	6527+46	0'
10	6527+90	0'
11	6528+03	2' LT
12	6528+02.5	2' RT
13	6528+28	2' LT
14	6528+28.5	2' RT

**UNDERPASS LUMINAIRE LOCATIONS**

NO.	STATION	OFFSET
15	6526+99.6	2' RT
16	6526+98.8	2' LT
17	6527+29.6	2' RT
18	6527+28.8	2' LT
19	6528+0.8	2' RT
20	6528+0.3	2' LT
21	6527+30.8	2' RT
22	6528+30.3	2' LT

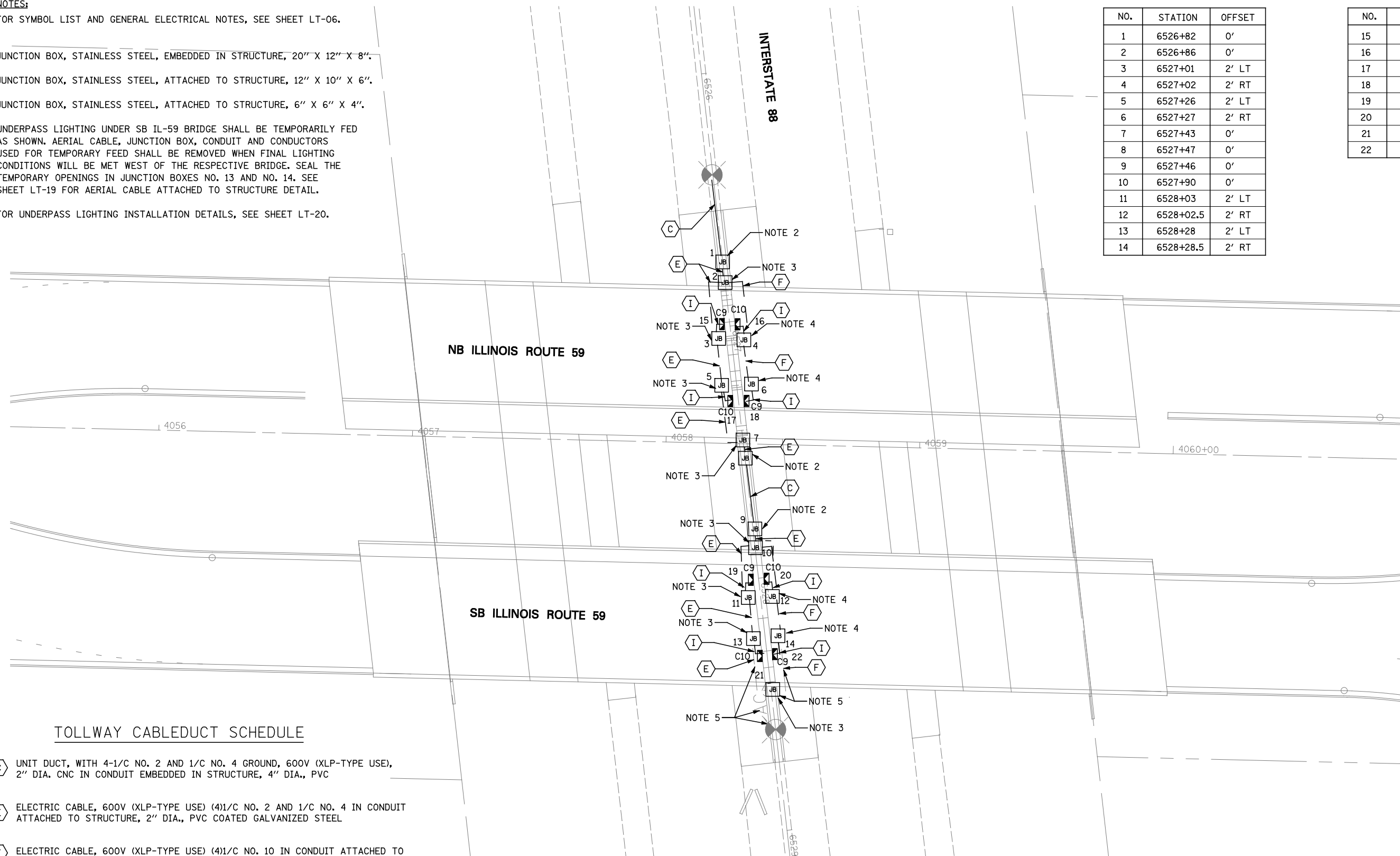

**TOLLWAY CABLEDUCT SCHEDULE**

- (C) UNIT DUCT, WITH 4-1/C NO. 2 AND 1/C NO. 4 GROUND, 600V (XLP-TYPE USE), 2" DIA. CNC IN CONDUIT EMBEDDED IN STRUCTURE, 4" DIA., PVC
- (E) ELECTRIC CABLE, 600V (XLP-TYPE USE) (4)1/C NO. 2 AND 1/C NO. 4 IN CONDUIT ATTACHED TO STRUCTURE, 2" DIA., PVC COATED GALVANIZED STEEL
- (F) ELECTRIC CABLE, 600V (XLP-TYPE USE) (4)1/C NO. 10 IN CONDUIT ATTACHED TO STRUCTURE, 3/4" DIA., PVC COATED GALVANIZED STEEL
- (I) ELECTRIC CABLE, 600V (XLP-TYPE USE) (3)1/C NO. 10 IN , 3/4" LIQUIDTIGHT FLEXIBLE METALLIC CONDUIT

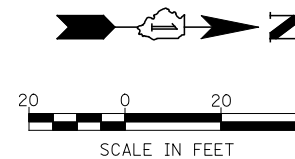



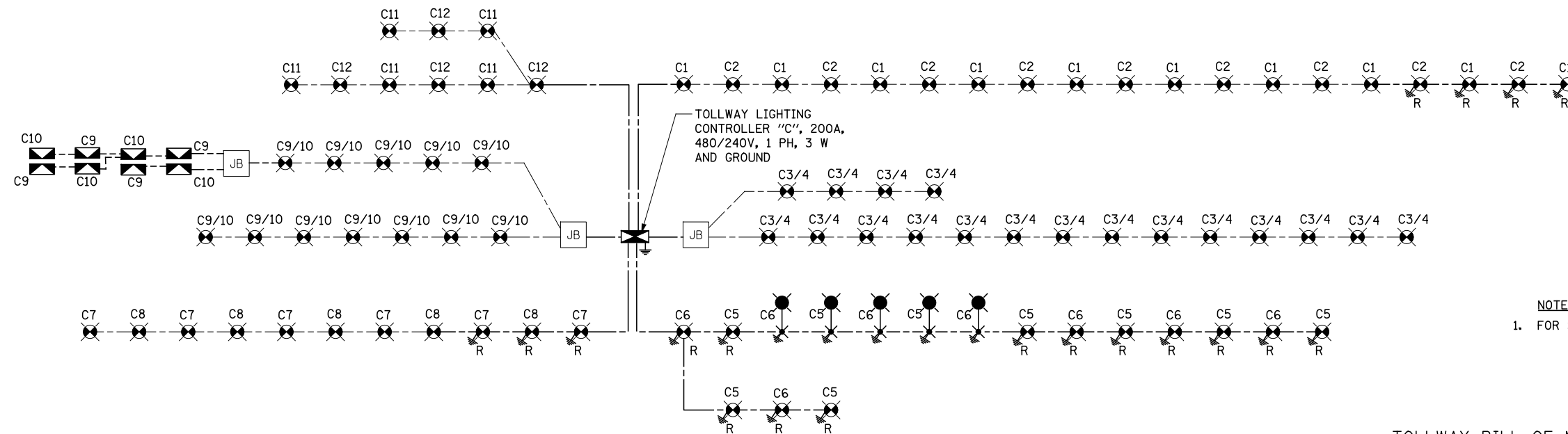

NOTES:  
1. FOR SYMBOL LIST AND GENERAL ELECTRICAL NOTES, SEE SHEET LT-06.

TOLLWAY BILL OF MATERIAL

DESIGNATION	UNIT OF MEASURE	QUANTITY
ELECTRIC SERVICE INSTALLATION	EACH	1
UNDERGROUND CONDUIT, PVC, 3" DIA.	FOOT	23
UNDERGROUND CONDUIT, PVC, 4" DIA.	FOOT	91
CONDUIT ATTACHED TO STRUCTURE, 3/4" DIA., PVC COATED GALVANIZED STEEL	FOOT	102
CONDUIT ATTACHED TO STRUCTURE, 2" DIA., PVC COATED GALVANIZED STEEL	FOOT	117
CONDUIT EMBEDDED IN STRUCTURE, 4" DIA., PVC	FOOT	45
JUNCTION BOX, STAINLESS STEEL, EMBEDDED IN STRUCTURE, 20" X 12" X 8"	EACH	3
JUNCTION BOX, STAINLESS STEEL, ATTACHED TO STRUCTURE, 12" X 10" X 6"	EACH	8
JUNCTION BOX, STAINLESS STEEL, ATTACHED TO STRUCTURE, 6" X 6" X 4"	EACH	4
HANDHOLE, TOLLWAY	EACH	1
UNIT DUCT, WITH 2-1/C NO. 2 AND 1/C NO. 4 GROUND, 600V (XLP-TYPE USE), 2" DIA. CNC	FOOT	898
UNIT DUCT, WITH 4-1/C NO. 2 AND 1/C NO. 4 GROUND, 600V (XLP-TYPE USE), 2" DIA. CNC	FOOT	9517
ELECTRIC CABLE IN CONDUIT, 600V (XLP-TYPE USE) 1/C NO. 10	FOOT	532
ELECTRIC CABLE IN CONDUIT, 600V (XLP-TYPE USE) 1/C NO. 4	FOOT	152
ELECTRIC CABLE IN CONDUIT, 600V (XLP-TYPE USE) 1/C NO. 2	FOOT	608
ELECTRIC CABLE IN CONDUIT, 600V (XLP-TYPE USE) 1/C NO. 3/0	FOOT	99
AERIAL CABLE, 4-1/C NO. 2, WITH MESSENGER WIRE	FOOT	10774
LUMINAIRE, SODIUM VAPOR, HORIZONTAL MOUNT, 400 WATT	EACH	3
UNDERPASS LUMINAIRE, 150 WATT, HIGH PRESSURE SODIUM VAPOR	EACH	8
TEMPORARY LUMINAIRE, SODIUM VAPOR, HIGH MAST, HORIZONTAL MOUNT, 750WATT	EACH	28
LIGHTING CONTROLLER, 200 AMPERE	EACH	1
LIGHTING CONTROLLER FOUNDATION, TYPE B	EACH	1
GROUND MOUNTED LIGHT POLE, ALUMINUM, 50 FT., 15 FT. MAST ARM	EACH	3
TEMPORARY WOOD POLE, 40 FT., CLASS 4	EACH	2
LIGHT POLE FOUNDATION (ROADWAY) STEEL HELIX (7 FT) OR CONCRETE	EACH	30
REMOVAL OF EXISTING LIGHTING UNIT, SALVAGE	EACH	28
REMOVAL OF UNDERPASS LUMINAIRE	EACH	8
REMOVAL OF EXISTING UNDERPASS LUMINAIRE FOUNDATION	EACH	27
REMOVAL OF EXISTING UNDERPASS LUMINAIRE FOUNDATION METAL	EACH	28
REMOVAL OF LIGHTING CONTROLLER	EACH	1
REMOVAL OF ELECTRIC SERVICE INSTALLATION	EACH	1
REMOVAL OF LIGHTING CONTROLLER FOUNDATION	EACH	1
REMOVAL OF EXISTING HANDHOLE	EACH	1
REMOVE TEMPORARY WOOD POLE	EACH	2
PROTECTION AND MAINTENANCE OF EXISTING UNDERPASS LIGHTING	L SUM	1
UNDERGROUND CONDUIT, PVC COATED GALVANIZED STEEL, 4" DIA.	FOOT	591
TEMPORARY WOOD POLE, 90 FT., CLASS 2, WITH 15 FT. MAST ARM, EMBEDDED	EACH	28

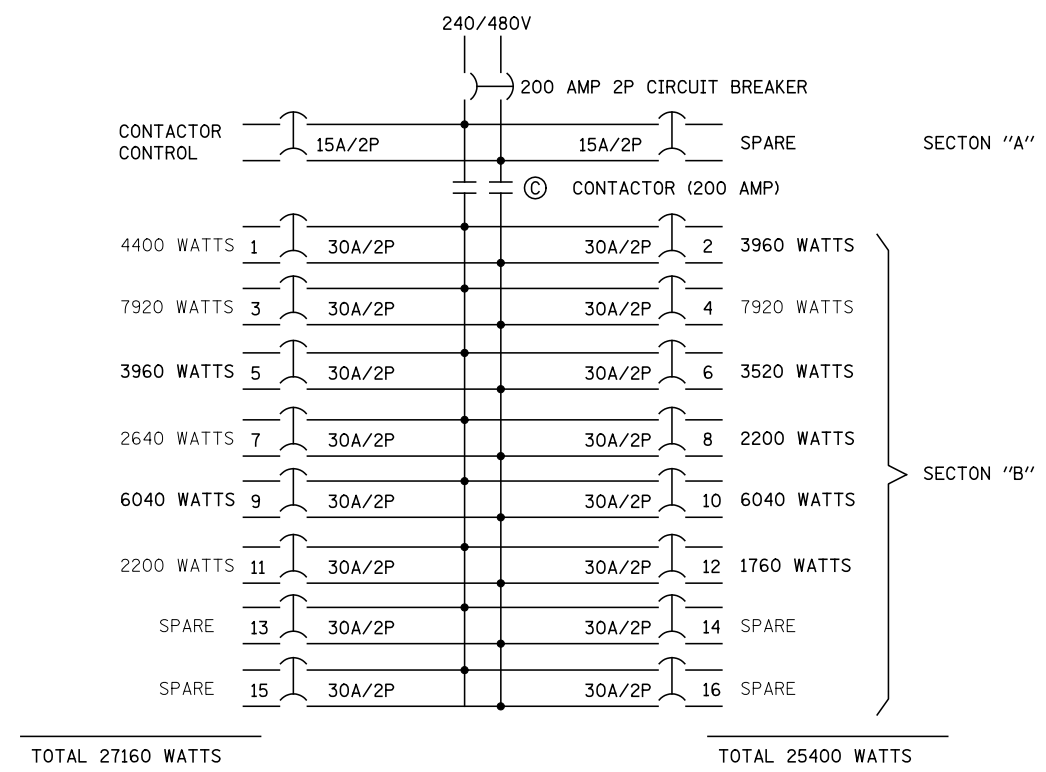

TOTAL 27160 WATTS                      TOTAL 25400 WATTS

LEGEND  
 - - - - - EXISTING CIRCUIT (LOAD PER EXISTING PANEL SCHEDULE)  
 - - - - - NEW CIRCUIT DUE TO REMOVAL, ADDITION OR RELOCATION OF LUMINAIRE(S)

ILLINOIS TOLLWAY NEW LIGHTING CONTROLLER "C"

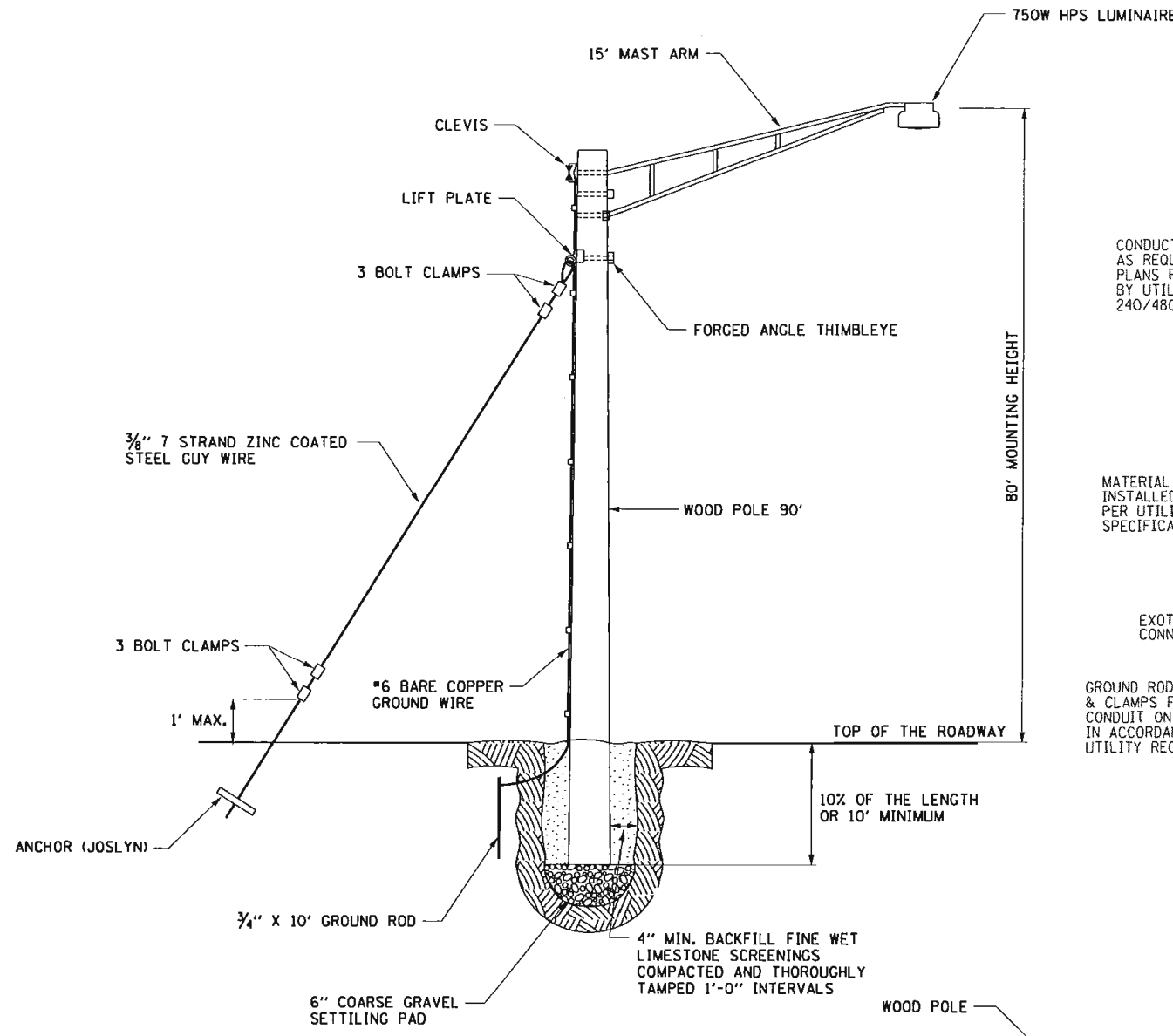

**TEMPORARY LIGHT POLE DETAIL**  
NOT TO SCALE

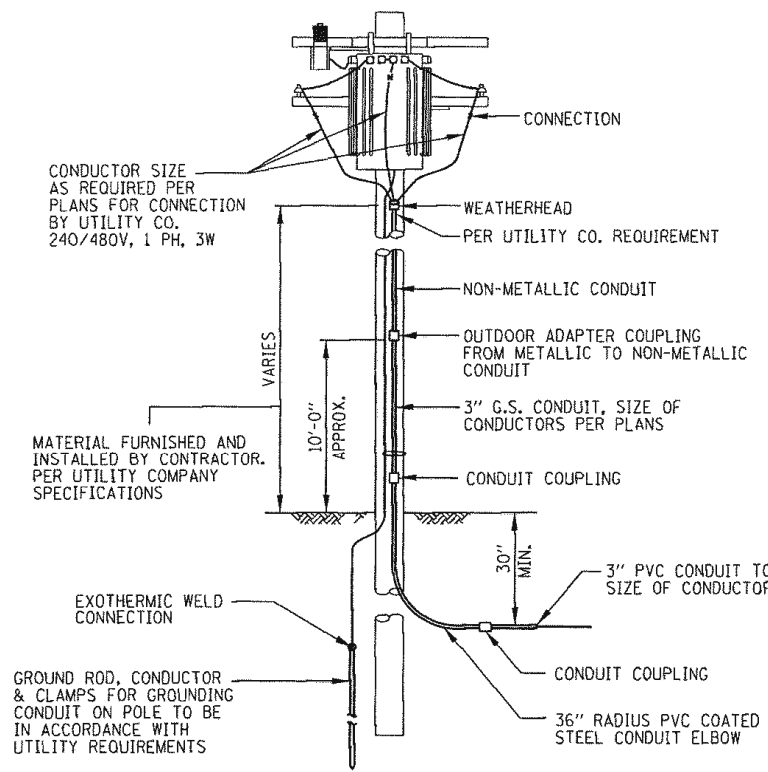

**UTILITY SERVICE POLE**  
SUBJECT TO UTILITY COMPANY APPROVAL  
NO SCALE

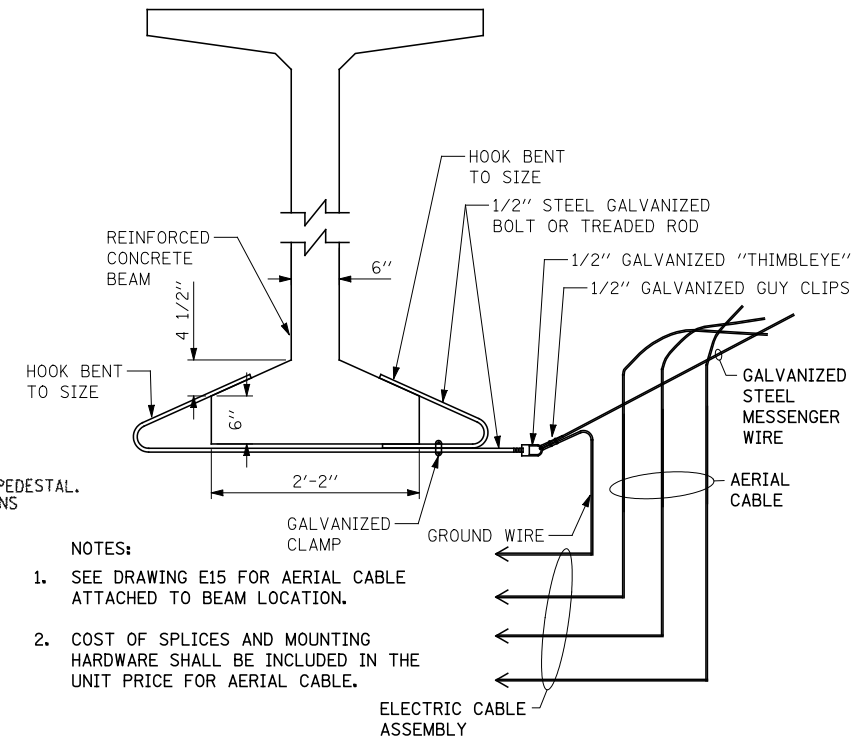

- NOTES:**
- SEE DRAWING E15 FOR AERIAL CABLE ATTACHED TO BEAM LOCATION.
  - COST OF SPLICES AND MOUNTING HARDWARE SHALL BE INCLUDED IN THE UNIT PRICE FOR AERIAL CABLE.

**AERIAL CABLE ATTACHED TO STRUCTURE DETAIL**  
NOT TO SCALE

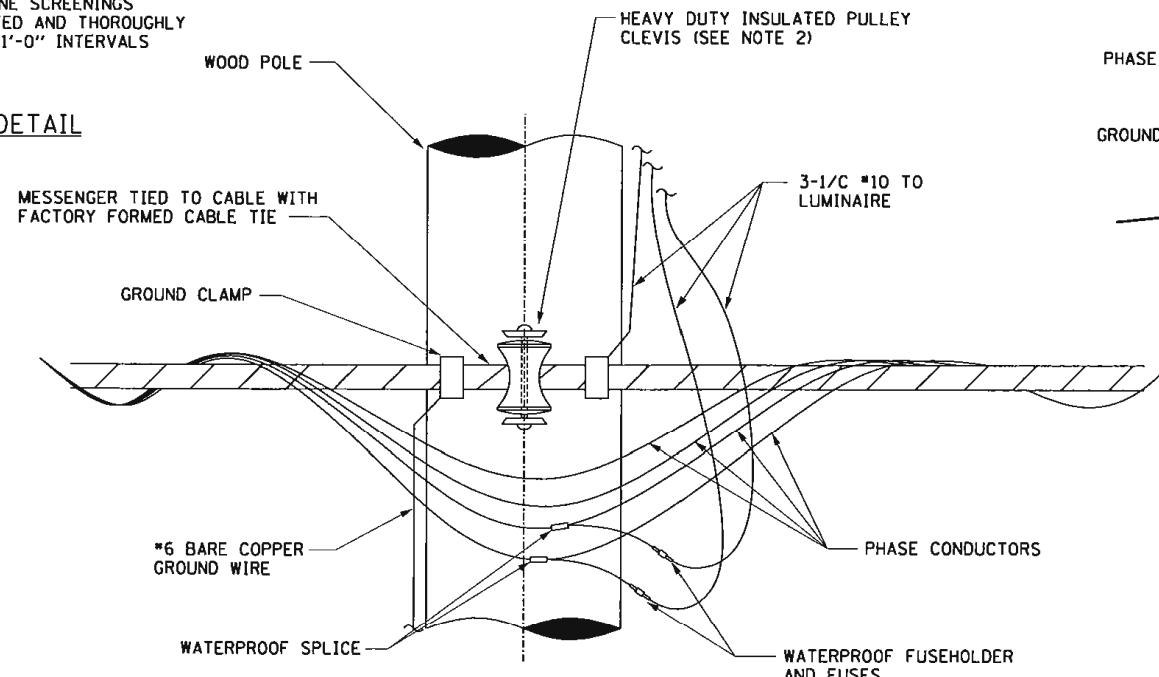

**TEMPORARY LIGHT POLE CABLE ATTACHMENT DETAIL**  
NOT TO SCALE

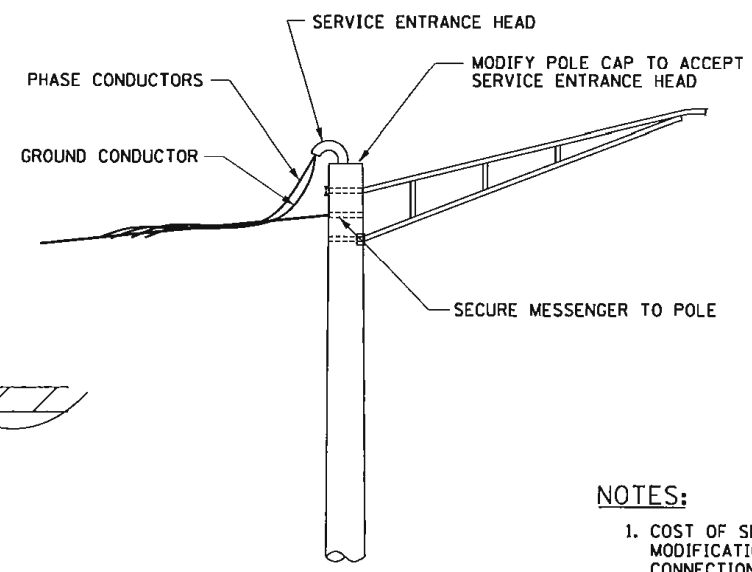

**TEMPORARY POWER FEED TO EXISTING ALUMINUM POLE**  
NOT TO SCALE

- NOTES:**
- COST OF SERVICE ENTRANCE HEAD, MODIFICATION OF POLE CAP AND CONNECTION ARE INCIDENTAL.
  - WITH THE APPROVAL OF THE ENGINEER, A SECONDARY CABLE SPREADER SECURED TO THE POLE MAY BE USED IN CONJUNCTION WITH THE QUADRUPEX IN LIEU OF THE HEAVY DUTY INSULATED PULLEY CLEVIS.

FILE NAME =  
#FILE#

USER NAME = #USER#  
DESIGNED MCP  
DRAWN MLB  
CHECKED MCP  
PLOT SCALE = #SCALE#  
PLOT DATE = #DATE#

DATE 10/15/2012

REVISED -  
REVISED -  
REVISED -  
REVISED -

**STATE OF ILLINOIS  
DEPARTMENT OF TRANSPORTATION**

**TOLLWAY LIGHTING DETAILS**

SCALE: AS SHOWN SHEET NO. 1 OF 2 SHEETS STA. TO STA.

F.A.P. RTE.	SECTION	COUNTY	TOTAL SHEETS	SHEET NO.
338	(112 & 113) WRS-5	DUPAGE	963	574
<b>LT-19</b>			CONTRACT NO. 60131	
ILLINOIS FED. AID PROJECT				

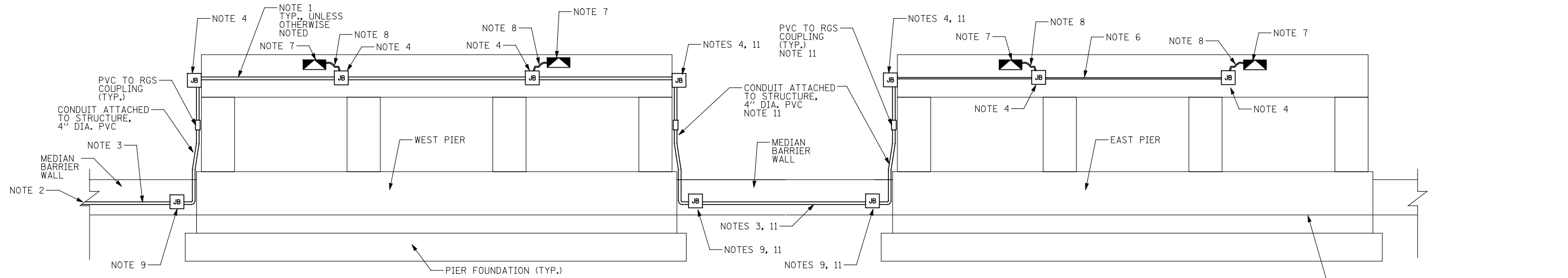

PIER ELEVATION LOOKING NORTH  
NOT TO SCALE

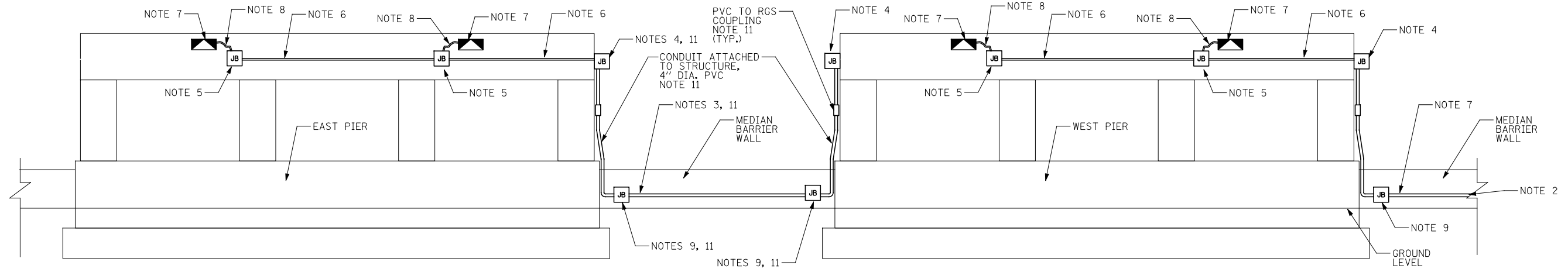

PIER ELEVATION LOOKING SOUTH  
NOT TO SCALE

**NOTES:**

1. ELECTRIC CABLE, (4) 1/C NO. 2 AND 1/C NO. 4 GROUND, 600V (XLP-TYPE USE) IN CONDUIT ATTACHED TO STRUCTURE, 2" DIA, PVC COATED GALVANIZED STEEL.
2. EXTEND EXISTING CONDUIT IN EXISTING BARRIER WALL TO REMAIN WITH NEW CONDUIT IN RECONSTRUCTED BARRIER WALL AND PULL NEW WIRING FROM EXISTING LIGHT POLE WEST OF PIER TO THE JUNCTION BOX EMBEDDED IN THE BARRIER WALL.
3. UNIT DUCT, WITH 4-1/C NO. 2 AND 1/C NO.4 GROUND, 600V (XLP-TYPE USE), 2" DIA. CNC IN CONDUIT EMBEDDED IN STRUCTURE, 4" DIA, PVC.
4. JUNCTION BOX, STAINLESS STEEL, ATTACHED TO STRUCTURE, 12"X10"X6".
5. JUNCTION BOX, STAINLESS STEEL, ATTACHED TO STRUCTURE, 6"X6"X4".
6. ELECTRIC CABLE, (5) 1/C NO. 10, 600V (XLP-TYPE USE) IN CONDUIT ATTACHED TO STRUCTURE, 3/4" DIA, PVC COATED GALVANIZED STEEL.
7. UNDERPASS LUMINAIRE, 150W, HIGH PRESSURE SODIUM VAPOR
8. ELECTRIC CABLE, 600V (XLP-TYPE USE) (3)1/C NO. 10 IN , 3/4" LIQUIDTIGHT FLEXIBLE METALLIC CONDUIT
9. JUNCTION BOX, STAINLESS STEEL, EMBEDDED IN STRUCTURE, 20"X12"X8"
10. LIQUID TIGHT FLEXIBLE METALLIC CONDUIT WITH WIRING, PLATE, NUTS, INSERTS AND ALL OTHER APPURTENANCES SHALL BE INCLUDED IN THE UNSERPASS LUMINAIRE PAY ITEM. NO ADDITIONAL PAYMENT WILL BE ALLOWED.
11. CONDUITS, WIRING, JUNCTION BOXES AND COUPLINGS BETWEEN PIERS ARE SHOWN ON BOTH ELEVATIONS. ONLY ONE ITEM IS REQUIRED TO BE INSTALLED.

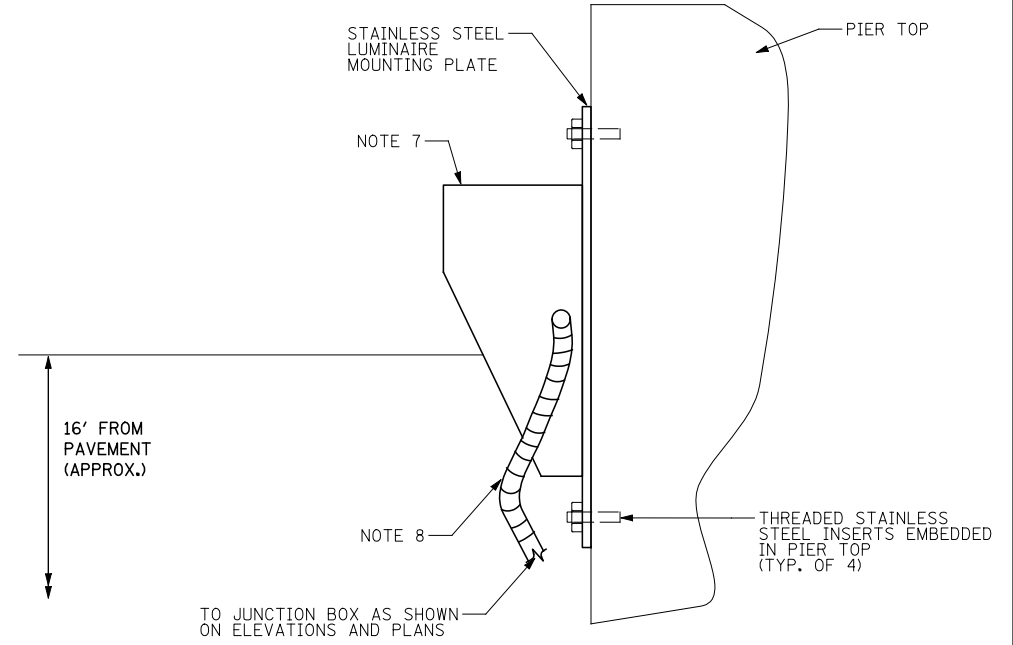

TYPICAL UNDERPASS LUMINAIRE INSTALLATION DETAIL  
(NOTE 10)  
NOT TO SCALE

FILE NAME =	USER NAME = \$USER*	DESIGNED MCP	REVISED -	<b>STATE OF ILLINOIS DEPARTMENT OF TRANSPORTATION</b>	<b>TOLLWAY UNDERPASS LIGHTING DETAILS</b>	F.A.P. RTE.	SECTION	COUNTY	TOTAL SHEETS	SHEET NO.	
\$FILEL#		DRAWN MLB	REVISED -			338	(112 & 113) WRS-5	DUPAGE	963	575	
		CHECKED MCP	REVISED -			<b>LT-20</b>		CONTRACT NO. 60131			
		DATE 10/15/2012	REVISED -			ILLINOIS FED. AID PROJECT					
					SCALE: AS SHOWN	SHEET NO. 2 OF 2 SHEETS	STA.	TO STA.			

**ROADWAY LIGHTING GENERAL NOTES**

- CONTRACTOR SHALL MAINTAIN EXISTING LIGHTING SYSTEM ALONG WINFIELD ROAD INTERCHANGES, THROUGHOUT THE PROJECT LIMITS, UNTIL RECONSTRUCTION WORK REQUIRES REMOVAL.
- ALL CABLE DUCT SHALL BE PLOWED-IN UNLESS SPECIFICALLY NOTED ON THE PLANS TO BE INSTALLED IN (A)-TRENCH, (B)-4" SCH. 40 PVC DUCT, OR (C)-A 3" OR 4" UNDERGROUND CONDUIT OR CASING TAGGED AS APPLICABLE.
- PRIOR TO INSTALLATION OF NEW CABLE DUCT, CONDUITS, JUNCTION BOXES, LIGHT STANDARD FOUNDATION AND APPURTENANCES, THE CONTRACTOR SHALL DETERMINE THE EXACT LOCATION OF EXISTING CONDUITS, CABLES AND UNDERGROUND UTILITIES. THE CONTRACTOR SHALL CALL J.U.L.I.E. TO AID IN THIS TASK.
- THE CONTRACTOR SHALL VERIFY ALL DATA SHOWN ON THE CONTRACT PLANS AND REFERENCE DRAWINGS WHICH WOULD AFFECT HIS WORK UNDER THIS CONTRACT AND THE OPERATION OF THE EXISTING ROADWAY LIGHTING AND SIGN LIGHTING SYSTEMS.
- ALL NEW CABLE DUCT, CONDUIT, JUNCTION BOXES AND APPURTENANCES ARE ILLUSTRATED DIAGRAMMATICALLY. THE ACTUAL LOCATION IN THE FIELD SHALL MEET WITH THE APPROVAL OF THE ENGINEER.
- THE ELECTRICAL MATERIALS SHALL BE NEW AND OF THE TYPE AND KINDS APPROVED BY THE FOLLOWING ORGANIZATIONS:  
 NATIONAL ELECTRICAL MANUFACTURERS ASSOCIATION  
 INSTITUTE OF ELECTRICAL AND ELECTRONIC ENGINEERS  
 ILLUMINATING ENGINEERING SOCIETY OF NORTH AMERICA  
 AMERICAN ASSOC. OF STATE HIGHWAY AND TRANSPORTATION OFFICIALS  
 U.S. DEPARTMENT OF TRANSPORTATION  
 UNDERWRITERS LABORATORIES  
 AMERICAN NATIONAL STANDARD INSTITUTE  
 INSULATED CABLE ENGINEERS ASSOCIATION
- MULTI-CABLE DUCT RUNS ARE TO BE INSTALLED IN COMMON TRENCH AND BACKFILLED.
- CONDUIT AND CABLE DUCT SHALL BE POSITIONED IN THE FIELD TO AVOID UTILITY INTERFERENCE-CONTRACTOR TO VERIFY LOCATIONS.
- WHERE MULTIPLE CABLE DUCTS OR CONDUITS ADJACENT TO EACH OTHER ARE INSTALLED IN A COMMON TRENCH, TRENCH AND BACKFILL WILL NOT BE PAID FOR EACH CABLE DUCT OR CONDUIT BUT WILL BE PAID FOR THE LENGTH OF THE COMMON TRENCH ONLY.
- ALL PITS USED FOR INSTALLED PUSHED (JACKED) STEEL CASING UNDER EXISTING ROADWAYS SHALL BE LOCATED FIVE (5) FEET MINIMUM CLEARANCE FROM THE EDGE OF THE SHOULDER. LOCATIONS OF THE CONDUIT CROSSING SHOWN ARE APPROXIMATE AND MAY BE SHIFTED AS NECESSARY TO MEET THE MINIMUM CLEARANCE REQUIREMENTS. THE PITS MUST BE ADEQUATELY GUARDED TO PROTECT THE MOTORIST. THE CONTRACTOR MUST SUBMIT PLANS FOR THE LOCATION AND SIZE OF THE PITS AND MAINTENANCE AND PROTECTION OF TRAFFIC AT THE SITE FOR THE APPROVAL OF THE ENGINEER.
- IF THE CONTRACTOR ELECTS TO SUPPLY GENERAL ELECTRIC ROADWAY LUMINAIRES, ALL LUMINAIRES LABELED TYPE M-C-II SHALL BE GENERAL ELECTRIC PHOTOMETRIC FILE NO. 35-177620. ALL LUMINAIRES LABELED TYPE S-C-II SHALL BE GENERAL ELECTRIC PHOTOMETRIC FILE NO. 35-177324 (S-C-II PHOTOMETRICS).  
  
 IF THE CONTRACTOR ELECTS TO SUPPLY HUBBELL ROADWAY LUMINAIRES, ALL LUMINAIRES LABELED TYPE M-C-II SHALL BE HUBBELL PHOTOMETRIC FILE NO. HP-03062. ALL LUMINAIRES LABELED TYPE M-C-III SHALL BE HUBBELL PHOTOMETRIC FILE NO. HP-03065.
- LUMINAIRES MUST BE INSTALLED ON LIGHT STANDARDS WITHIN A MAXIMUM OF 48 HOURS AFTER LIGHT STANDARD IS ERECTED.
- WHERE THE PROPOSED UNDERPASS LUMINAIRES ARE TO BE INSTALLED, THE LUMINAIRES AND RELATED WIRING SHALL BE INSTALLED AS SHOWN ON SHEETS RDL-35, RDL-36, RDL-37 AND RDL-38.
- WHERE THE EXISTING LIGHT POLE IS TO REMAIN, THE EXISTING LUMINAIRE(S) SHALL BE REMOVED AND REPLACED WITH NEW FLAT LENS CUT-OFF TYPE LUMINAIRE(S).
- WHERE THE EXISTING LIGHT POLE IS TO BE RELOCATED, THE EXISTING LUMINAIRE(S) SHALL BE REMOVED AND REPLACED WITH NEW FLAT LENS CUT-OFF TYPE LUMINAIRE(S).
- ALL MEDIAN FOUNDATIONS AND MEDIAN CABLE DUCT CASING TO BE INSTALLED IN SEPARATE CONTRACTS AND THEREFORE SHOWN AS EXISTING IN THESE PLANS.
- WHERE THE PROPOSED SIGN PANELS ARE TO BE INSTALLED, THE PROPOSED SIGN LUMINAIRES SHALL BE INSTALLED AS SHOWN ON SHEETS RDL-39 AND RDL-40.
- WHERE THE PROPOSED JUNCTION BOXES ARE TO BE INSTALLED, THE EMBEDDED JUNCTION BOXES SHALL BE INSTALLED AS SHOWN ON SHEETS RDL-42, RDL-43 AND RDL-44.

**CABLEDUCT SCHEDULE**

- (A) 2" CABLE DUCT, 4 #2 (5KV TYPE XLP) AND 1 #8 GROUND (600V TYPE XHHW) PULLED IN 4" SCHEDULE 40 PVC DUCT EMBEDDED IN CONCRETE BARRIER
- (B) 4" SCHEDULE 40 PVC DUCT EMBEDDED IN CONCRETE BARRIER
- (C) 2" CABLE DUCT, 4 #2 (5KV TYPE XLP) AND 1 #8 GROUND (600V TYPE XHHW) PLOWED IN
- (D) 2" CABLE DUCT, 2 #2 (5KV TYPE XLP) AND 1 #8 GROUND (600V TYPE XHHW) PLOWED IN
- (E) 2" CABLE DUCT, 4 #2 (5KV TYPE XLP) AND 1 #8 GROUND (600V TYPE XHHW) PULLED IN CASING
- (F) 2" PVC COATED RGS CONDUIT, 3 #2 (5 KV TYPE XLP) AND 1 #2 GROUND (600V TYPE XHHW) INSTALLED IN TRENCH
- (G) 2" CABLE DUCT, 4 #2 (5KV TYPE XLP) AND 1 #8 GROUND (600V TYPE XHHW) INSTALLED IN TRENCH
- (H) 2" CABLE DUCT, 2 #2 (5KV TYPE XLP) AND 1 #8 GROUND (600V TYPE XHHW) INSTALLED IN TRENCH
- (I) 2" CABLE DUCT, 4 #2 (5KV TYPE XLP) AND 1 #8 GROUND (600V TYPE XHHW) PULLED IN 2" SCHEDULE 40 PVC DUCT EMBEDDED IN PARAPET
- (J) 2" CABLE DUCT, 2 #2 (5KV TYPE XLP) AND 1 #8 GROUND (600V TYPE XHHW) PULLED IN 2" SCHEDULE 40 PVC DUCT EMBEDDED IN PARAPET
- (K1) 3/4" PVC COATED RGS CONDUIT, 2 #10 AND 1 #10 GROUND (ALL 600V TYPE XHHW) ATTACHED TO STRUCTURE
- (K2) 3/4" LIQUIDTIGHT FLEXIBLE METALLIC CONDUIT, 2 #10 AND 1 #10 GROUND (ALL 600V TYPE XHHW)
- (L) 4" PVC COATED RGS CONDUIT, 4 #2 (5KV TYPE XLP) AND 1 #8 GROUND (600V TYPE XHHW) ATTACHED TO STRUCTURE
- (N2) 1" PVC COATED RGS CONDUIT, 2 #10 AND 1 #10 GROUND (ALL 600V TYPE XHHW) ATTACHED TO STRUCTURE
- (N3) 1" PVC COATED RGS CONDUIT, 4 #10 AND 1 #10 GROUND (ALL 600V TYPE XHHW) ATTACHED TO STRUCTURE
- (N4) 2" PVC COATED RGS CONDUIT, 4 #10 AND 1 #10 GROUND (ALL 600V TYPE XHHW) ATTACHED TO STRUCTURE
- (O) 4" RIGID STEEL CONDUIT W/2" CABLE DUCT, 2 #2 LINE (5 KV TYPE XLP) AND 1 #8 AWG NEUTRAL (600V TYPE XHHW)
- (R) 1" PVC COATED RGS CONDUIT, 2 #4 (600V TYPE XHHW) AND 1 #8 (600V TYPE XHHW) IN TRENCH

**LIST OF TOLLWAY STANDARD DRAWINGS**

SHEET NO. H1	STANDARD RL-03-01
SHEET NO. H2	STANDARD RL-03-02
SHEET NO. H3	STANDARD RL-03-03
SHEET NO. H4	STANDARD RL-03-04
SHEET NO. H5	STANDARD RL-03-05
SHEET NO. H6	STANDARD RL-03-06
SHEET NO. H7	STANDARD RL-03-07
SHEET NO. H9	STANDARD RL-03-09
SHEET NO. H10	STANDARD RL-03-10
SHEET NO. H11	STANDARD RL-03-11
SHEET NO. H12	STANDARD RL-03-12
SHEET NO. H14	STANDARD RL-03-14
SHEET NO. H18	STANDARD SE-03-01
SHEET NO. H19	STANDARD SE-03-02
SHEET NO. H20	STANDARD SE-03-03
SHEET NO. H21	STANDARD SE-03-04
SHEET NO. H22	STANDARD SE-03-05
SHEET NO. H23	STANDARD SE-03-06
SHEET NO. H25	STANDARD SE-03-08

**SYMBOLS & LEGEND:**

- EXISTING LIGHT POLE TO REMAIN
- EXISTING LIGHT POLE TO BE RELOCATED
- SHALL APPLY FOR REMOVAL OF EXISTING EQUIPMENT
- EXISTING OUTDOOR ROADWAY LIGHTING CONSOLE
- EXISTING OUTDOOR ROADWAY CONSOLE TO BE REMOVED, SALVAGED AND DELIVERED TO ISTHA
- TEMPORARY 750 WATT HPS LUMINAIRE AND WOOD POLE, 90 FT. WITH 15 FT. MAST ARM
- NEW OUTDOOR ROADWAY LIGHTING CONSOLE WITH FOUNDATION
- NEW 400 WATT HPS LUMINAIRE, POLE AND FOUNDATION
- SINGLE ARM, GROUND MOUNTED (EXCEPTION: WHEN NOTED IN PLAN, IT COULD ALSO BE A 100 OR A 250 WATT HPS LUMINAIRE. REFER TO RDL'S 12 & 16)
- NEW 400 WATT HPS LUMINAIRE, POLE AND FOUNDATION, DOUBLE ARM, MEDIAN MOUNTED.
- NEW 400 WATT HPS LUMINAIRE, AND POLE, SINGLE ARM, RETAINING WALL OR PARAPET MOUNTED.
- RELOCATED LIGHT POLE
- NEW 400 WATT HPS FLOODLIGHT LUMINAIRE
- CABLEDUCT OR CONDUIT TAG, SEE CABLEDUCT SCHEDULE FOR DESCRIPTION
- NEW CABLEDUCT OR CONDUIT IN PUSHED CASING
- RIGID GALVANIZED STEEL CONDUIT, SLEEVE, TRENCHED OR PUSHED
- NEW CABLEDUCT OR CONDUIT
- AERIAL CABLE
- TEMPORARY WOOD POLE
- EXISTING JUNCTION BOX
- NEW LIGHT DUTY JUNCTION BOX
- TYPE "A" JUNCTION BOX
- TYPE "B" JUNCTION BOX
- TRANSFORMER
- S-FOR SINGLE, D-FOR DOUBLE, Q-FOR QJAD ARM MAST, 15 FT. LONG NOMINAL HEIGHT, 50-FT. CIRCUIT NUMBER
- STA. 1+25 - STATION OF LIGHT STANDARD
- LIGHT DISTRIBUTION TYPE CONTROL CATEGORY, C-FOR CUT-OFF, S-FOR SEMI CUT-OFF SPACING RANGE, M-FOR MEDIUM, S-FOR SHORT
- EXISTING UNDERPASS LUMINAIRE
- NEW UNDERPASS LUMINAIRE
- EXISTING SIGN LUMINAIRE
- NEW 250 WATT M.V. SIGN LUMINAIRE
- EXISTING OVERHEAD SIGN STRUCTURE
- PROPOSED OVERHEAD SIGN STRUCTURE
- J.B. JUNCTION BOX
- A.T.S. ATTACHED TO STRUCTURE
- N.T.S. NOT TO SCALE
- G.S. GALVANIZED STEEL
- W.P. WEATHERPROOF
- R.S.C. RIGID STEEL CONDUIT
- GRND. GROUND
- EXISTING CABLEDUCT OR CONDUIT
- WEATHER STATION EQUIPMENT
- POLE MOUNTED TRANSFORMER

RDL-01

DRAWN BY JDM  
 CHECKED BY SM  
 SCALE NONE  
 DATE 2-21-05

**K&E** KAM ENGINEERING, INC.  
 CONSULTING ENGINEERS  
 707A Davis Road, Suite 205  
 Elgin, Illinois 60123-1369

**THE ILLINOIS STATE TOLL HIGHWAY AUTHORITY**  
 2700 OGDEN AVENUE  
 DOWNERS GROVE, ILLINOIS 60515

REVISIONS		
NO.	DATE	DESCRIPTION
1	08/03/05	ADDED SYMBOL FOR POLE MOUNTED TRANSFORMER
2	01/16/06	REVISED DESCRIPTION OF CABLE "O"
3	01/17/06	ADDED SYMBOL TO REMOVE EXISTING CONSOLE

CONTRACT NO. RR-04-5198	DRAWING NO.
ROADWAY LIGHTING LEGEND, SYMBOLS AND NOTES	272 OF 601

FOR INFORMATION ONLY

FILE NAME =	USER NAME = #USER#	DESIGNED MCP	REVISED -	<p><b>STATE OF ILLINOIS</b>  <b>DEPARTMENT OF TRANSPORTATION</b></p>	<p><b>EXISTING LIGHTING PLAN</b>  <b>(FOR REFERENCE)</b></p>	F.A.P. RTE.	SECTION	COUNTY	TOTAL SHEETS	SHEET NO.
#FILEL#	DRAWN MLB	REVISIONS -	338			(112 & 113) WRS-5	DUPAGE	963	576	
PLOT SCALE = #SCALE#	CHECKED MCP	REVISIONS -	<b>LT-21</b>			CONTRACT NO. 60131				
PLOT DATE = #DATE#	DATE 10/15/2012	REVISIONS -	ILLINOIS FED. AID PROJECT							
SCALE: AS SHOWN		SHEET NO. 1 OF 9 SHEETS		STA. 4038+00 TO STA. 4044+00						

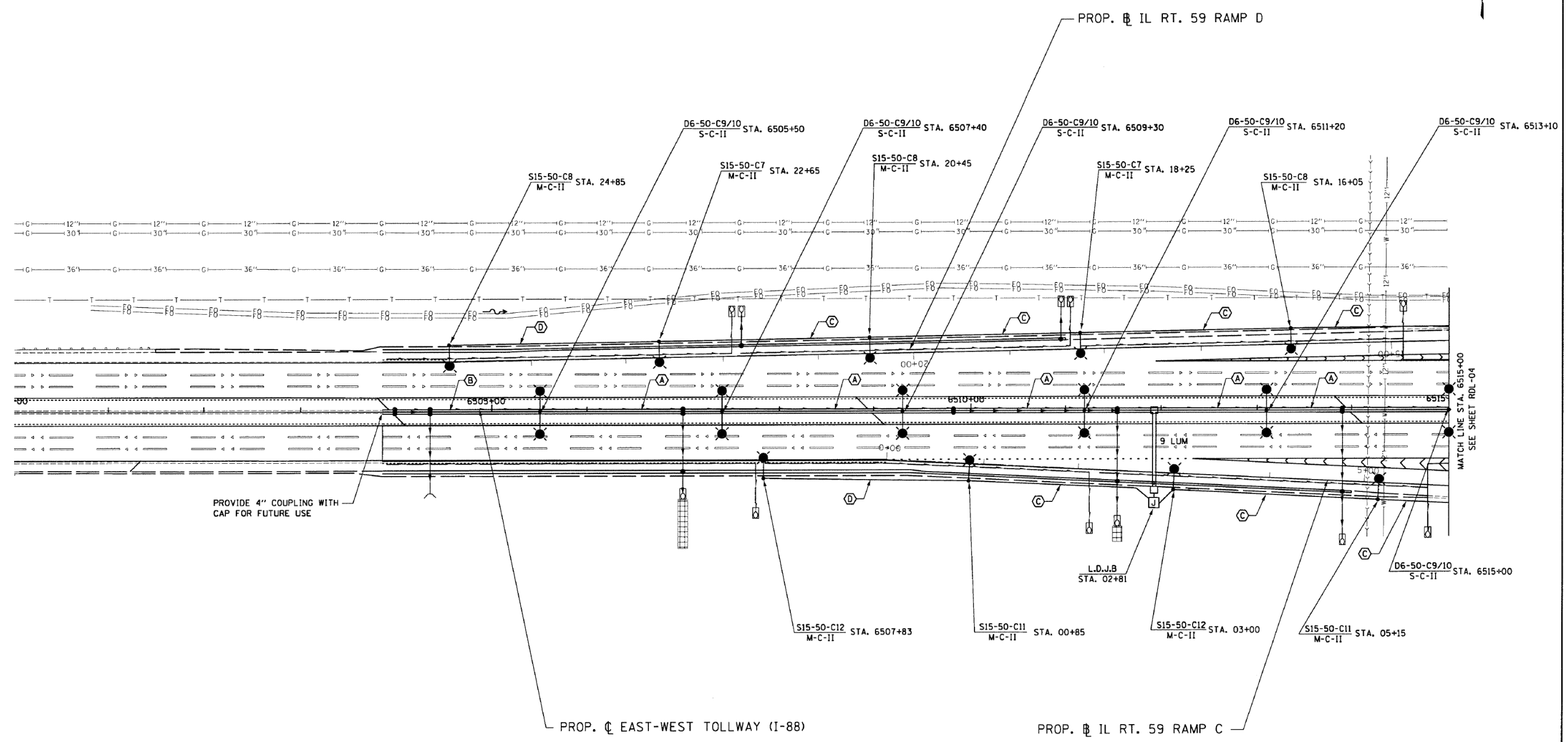

NOTES:  
1. SEE SHEET RDL-01 FOR ELECTRICAL SYMBOLS AND LEGEND.

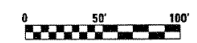

RDL-03

DRAWN BY JDM  
CHECKED BY SM  
SCALE 1"=50'  
DATE 3/1/05

**K&E** KAM ENGINEERING, INC.  
CONSULTING ENGINEERS  
707A Davis Road, Suite 205  
Elgin, Illinois 60123-1369

**THE ILLINOIS STATE TOLL HIGHWAY AUTHORITY**  
2700 OGDEN AVENUE  
DOWNERS GROVE, ILLINOIS 60515

REVISIONS		
NO.	DATE	DESCRIPTION
1	3/01/05	NEW SHEET

CONTRACT NO. RR-04-5198  
PROPOSED LIGHTING PLAN

DRAWING NO.  
274 OF 601

FOR INFORMATION ONLY

FILE NAME =	USER NAME = #USER#	DESIGNED MCP	REVISED -
#FILEL#		DRAWN MLB	REVISED -
		CHECKED MCP	REVISED -
		DATE 10/15/2012	REVISED -

**STATE OF ILLINOIS**  
**DEPARTMENT OF TRANSPORTATION**

**EXISTING LIGHTING PLANS**  
**(FOR REFERENCE)**

SCALE: AS SHOWN SHEET NO. 2 OF 9 SHEETS STA. 4038+00 TO STA. 4044+00

F.A.P. RTE.	SECTION	COUNTY	TOTAL SHEETS	SHEET NO.
338	(112 & 113) WRS-5	DUPAGE	963	577
<b>LT-22</b>		CONTRACT NO. 60131		
ILLINOIS FED. AID PROJECT				

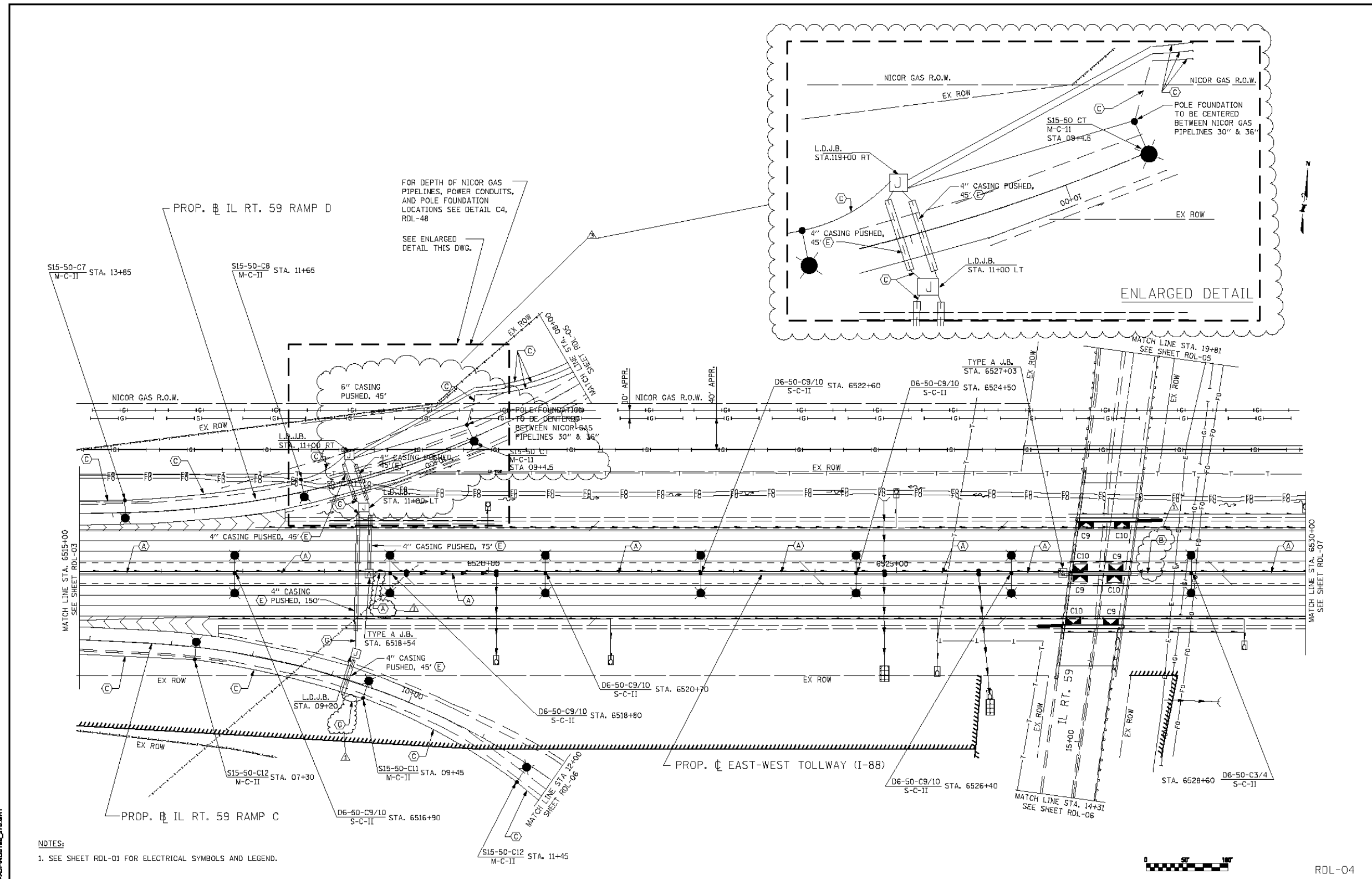

DRAWN BY JDM CHECKED BY SM	SCALE 1"=50' DATE 3/1/05	<b>KAM ENGINEERING, INC.</b> CONSULTING ENGINEERS 707A Davis Road, Suite 205 Elgin, Illinois 60123-1369	<b>THE ILLINOIS STATE TOLL HIGHWAY AUTHORITY</b> 2700 OGDEN AVENUE DOWNERS GROVE, ILLINOIS 60515	<table border="1"> <thead> <tr> <th colspan="2">REVISIONS</th> </tr> <tr> <th>NO.</th> <th>DATE</th> </tr> </thead> <tbody> <tr> <td>1</td> <td>05/25/05</td> </tr> <tr> <td>2</td> <td>06/22/05</td> </tr> <tr> <td>3</td> <td>09/12/06</td> </tr> </tbody> </table>	REVISIONS		NO.	DATE	1	05/25/05	2	06/22/05	3	09/12/06	CONTRACT NO. RR-04-5198 PROPOSED LIGHTING PLAN	DRAWING NO. 275 OF 601
REVISIONS																
NO.	DATE															
1	05/25/05															
2	06/22/05															
3	09/12/06															

FOR INFORMATION ONLY

FILE NAME =	USER NAME = #USER#	DESIGNED MCP	REVISED -	<b>STATE OF ILLINOIS DEPARTMENT OF TRANSPORTATION</b>	<b>EXISTING LIGHTING PLAN (FOR REFERENCE)</b>	F.A.P. RTE.	SECTION	COUNTY	TOTAL SHEETS	SHEET NO.
#FILE#		DRAWN MLB	REVISED -			338	(112 & 113) WRS-5	DUPAGE	963	578
PLOT SCALE = #SCALE#		CHECKED MCP	REVISED -			<b>LT-23</b>		CONTRACT NO. 60131		
PLOT DATE = #DATE#		DATE 10/15/2012	REVISED -			ILLINOIS FED. AID PROJECT				

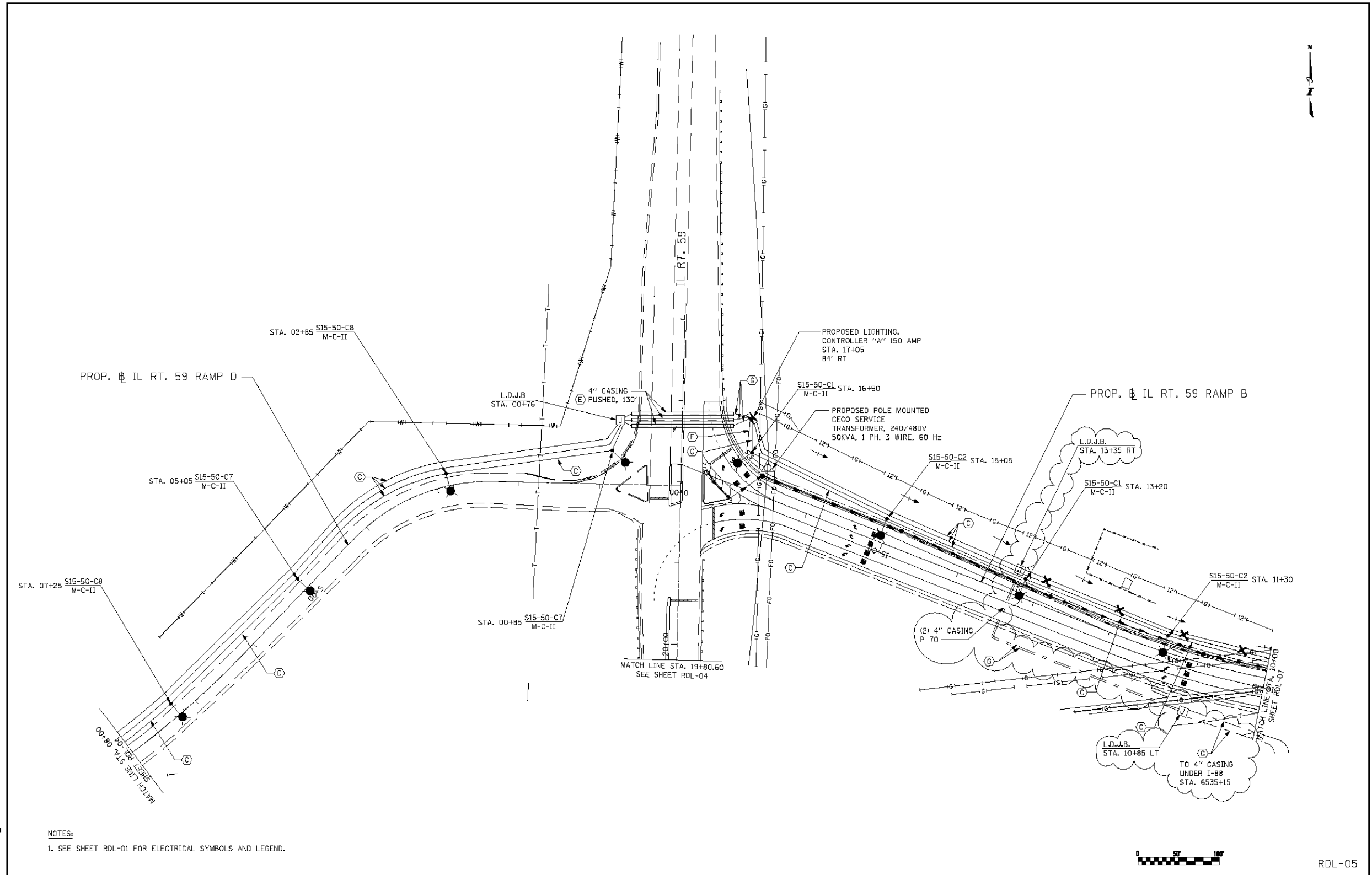

NOTES:  
1. SEE SHEET RDL-01 FOR ELECTRICAL SYMBOLS AND LEGEND.



RDL-05

DRAWN BY JDM CHECKED BY SM	SCALE 1"=50' DATE 3/1/05	K&E ENGINEERING, INC. CONSULTING ENGINEERS 707A Davis Road, Suite 205 Elgin, Illinois 60123-1369	THE ILLINOIS STATE TOLL HIGHWAY AUTHORITY 2700 OGDEN AVENUE DOWNERS GROVE, ILLINOIS 60515	REVISIONS NO. DATE DESCRIPTION 1 3/01/05 NEW SHEET 2 05/12/06 RECORD DRAWINGS	CONTRACT NO. RR-04-5198 PROPOSED LIGHTING PLAN	DRAWING NO. 276 OF 601
				FOR INFORMATION ONLY		

FILE NAME =	USER NAME = #USER#	DESIGNED MCP	REVISED -	STATE OF ILLINOIS DEPARTMENT OF TRANSPORTATION	EXISTING LIGHTING PLAN (FOR REFERENCE)	F.A.P. RTE.	SECTION	COUNTY	TOTAL SHEETS	SHEET NO.
#FILEL#		DRAWN MLB	REVISED -			338	(112 & 113) WRS-5	DUPAGE	963	579
PLOT SCALE = #SCALE#		CHECKED MCP	REVISED -			LT-24		CONTRACT NO. 60131		
PLOT DATE = #DATE#		DATE 10/15/2012	REVISED -			SCALE: AS SHOWN	SHEET NO. 4 OF 9 SHEETS	STA. 4038+00	TO STA. 4044+00	

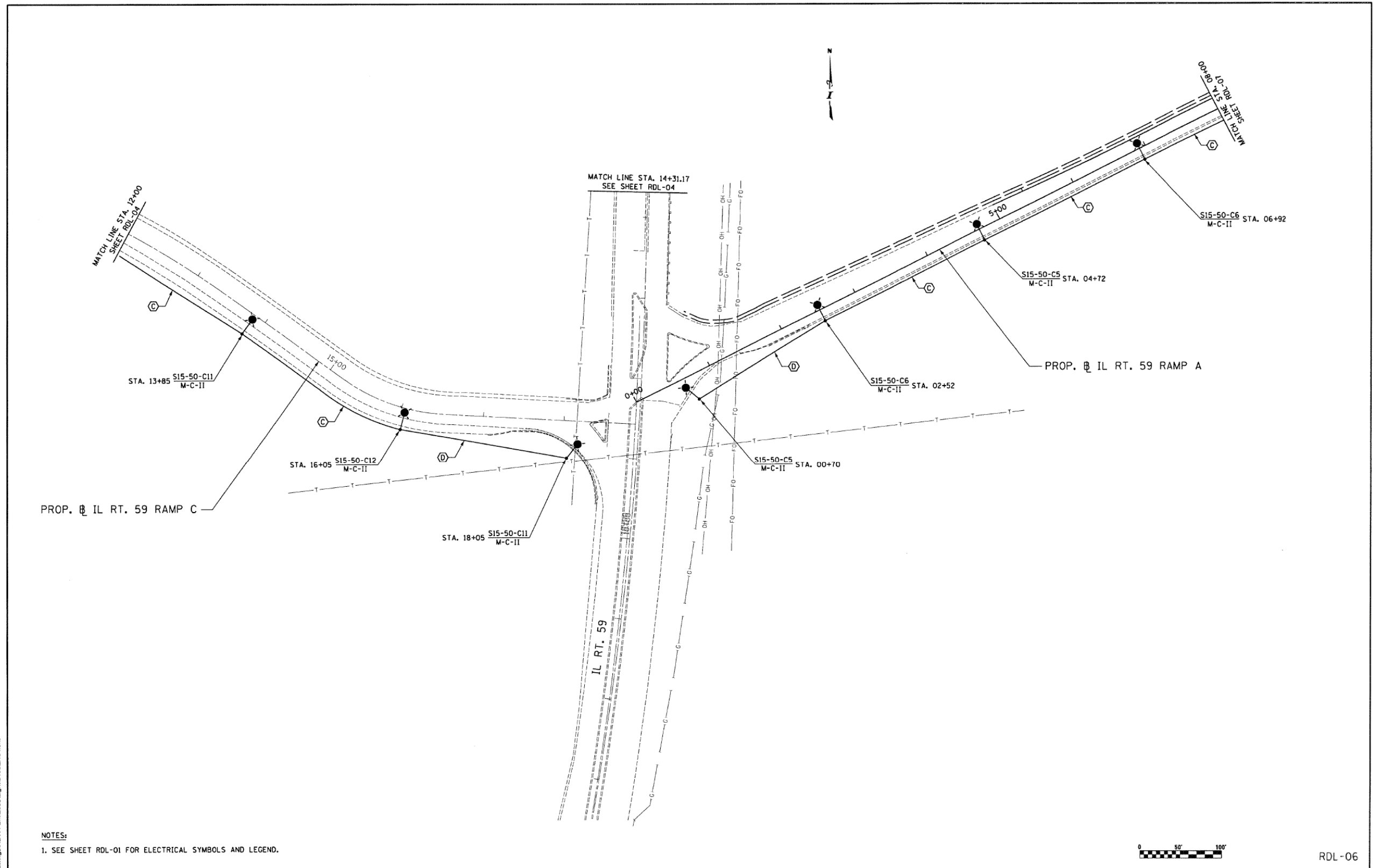

NOTES:  
1. SEE SHEET RDL-01 FOR ELECTRICAL SYMBOLS AND LEGEND.

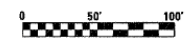

RDL-06

<b>DRAWN BY</b> JDM	<b>SCALE</b> 1"=50'		<b>KAM ENGINEERING, INC.</b> CONSULTING ENGINEERS 707A Davis Road, Suite 205 Evanston, Illinois 60123-1369		<b>THE ILLINOIS STATE TOLL HIGHWAY AUTHORITY</b> 2700 OGDEN AVENUE DOWNERS GROVE, ILLINOIS 60515	<b>REVISIONS</b>		<b>CONTRACT NO. RR-04-5198</b>	<b>DRAWING NO.</b> 277 OF 601
<b>CHECKED BY</b> SM	<b>DATE</b> 3/1/05					<table border="1"> <thead> <tr> <th>NO.</th> <th>DATE</th> <th>DESCRIPTION</th> </tr> </thead> <tbody> <tr> <td>1</td> <td>3/01/05</td> <td>NEW SHEET</td> </tr> </tbody> </table>	NO.		
NO.	DATE	DESCRIPTION							
1	3/01/05	NEW SHEET							

FOR INFORMATION ONLY

FILE NAME =	USER NAME = \$USER*	DESIGNED MCP	REVISED -	<b>STATE OF ILLINOIS</b> <b>DEPARTMENT OF TRANSPORTATION</b>	<b>EXISTING LIGHTING PLAN</b> <b>(FOR REFERENCE)</b>	F.A.P. RTE.	SECTION	COUNTY	TOTAL SHEETS	SHEET NO.
\$FILEL\$		DRAWN MLB	REVISED -			338	(112 & 113) WRS-5	DUPAGE	963	580
PLOT SCALE = \$SCALE*		CHECKED MCP	REVISED -			<b>LT-25</b>		CONTRACT NO. 60131		
PLOT DATE = \$DATE*		DATE 10/15/2012	REVISED -			SCALE: AS SHOWN	SHEET NO. 5 OF 9 SHEETS	STA. 4038+00	TO STA. 4044+00	



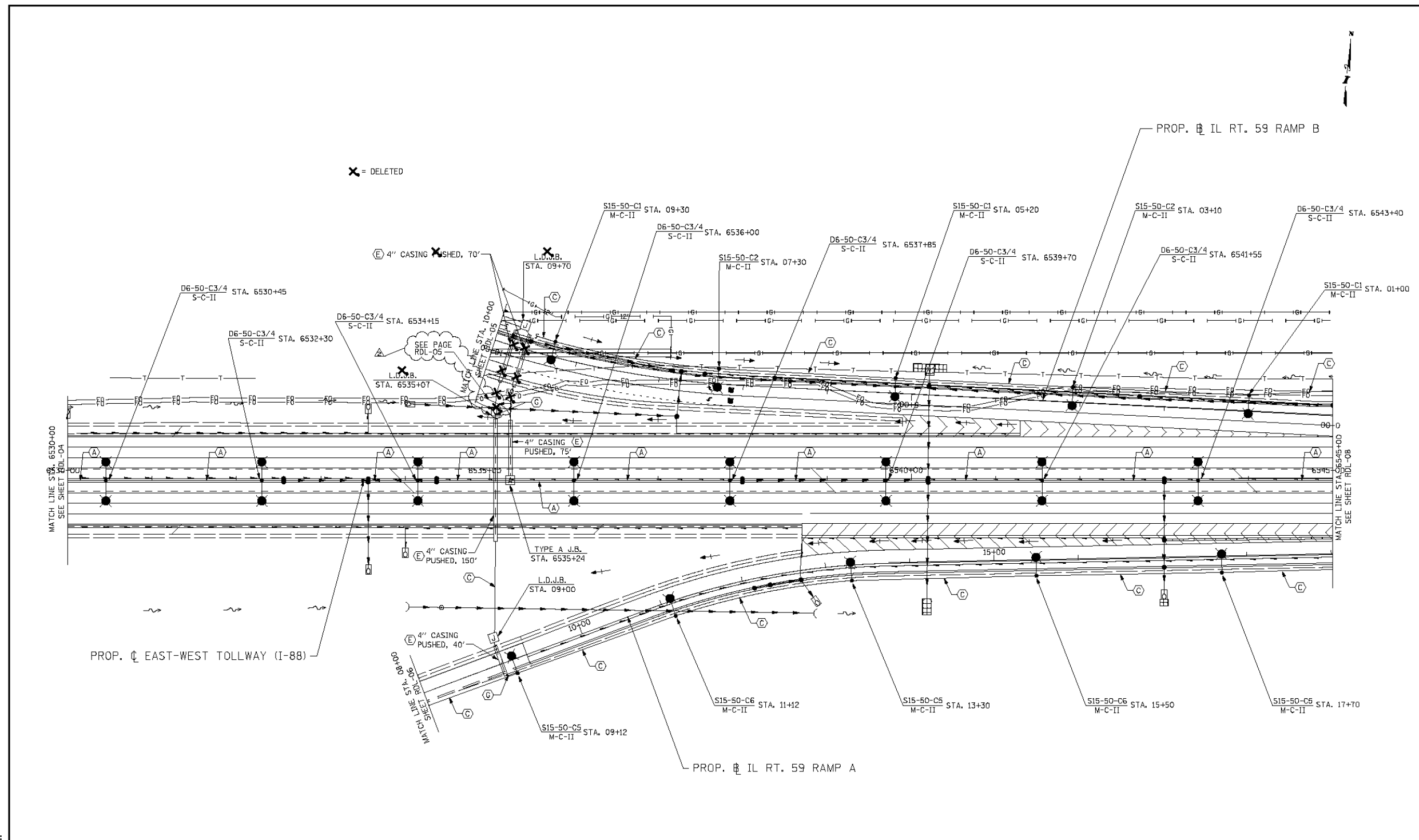

NOTES:  
 1. SEE SHEET RDL-01 FOR ELECTRICAL SYMBOLS AND LEGEND.



RDL-07

DRAWN BY JDM SCALE 1"=50'  
 CHECKED BY SM DATE 3/1/05

**K&E** KAM ENGINEERING, INC.  
 CONSULTING ENGINEERS  
 707A Davis Road, Suite 205  
 Elgin, Illinois 60123-1369

**THE ILLINOIS STATE TOLL HIGHWAY AUTHORITY**  
 2700 OGDEN AVENUE  
 DOWNERS GROVE, ILLINOIS 60515

REVISIONS		
NO.	DATE	DESCRIPTION
1	3/01/05	NEW SHEET
2	09/12/06	RECORD DRAWINGS

CONTRACT NO. RR-04-5198  
 PROPOSED LIGHTING PLAN

DRAWING NO.  
 278 OF 601

FOR INFORMATION ONLY

FILE NAME =	USER NAME = #USER#	DESIGNED MCP	REVISED -	<b>STATE OF ILLINOIS DEPARTMENT OF TRANSPORTATION</b>	<b>EXISTING LIGHTING PLAN (FOR REFERENCE)</b>	F.A.P. RTE.	SECTION	COUNTY	TOTAL SHEETS	SHEET NO.
#FILE#		DRAWN MLB	REVISED -			338	(112 & 113) WRS-5	DUPAGE	963	581
PLOT SCALE = #SCALE#		CHECKED MCP	REVISED -			<b>LT-26</b>		CONTRACT NO. 60131		
PLOT DATE = #DATE#		DATE 10/15/2012	REVISED -			ILLINOIS FED. AID PROJECT				
				SCALE: AS SHOWN	SHEET NO. 6 OF 9 SHEETS	STA. 4038+00 TO STA. 4044+00				

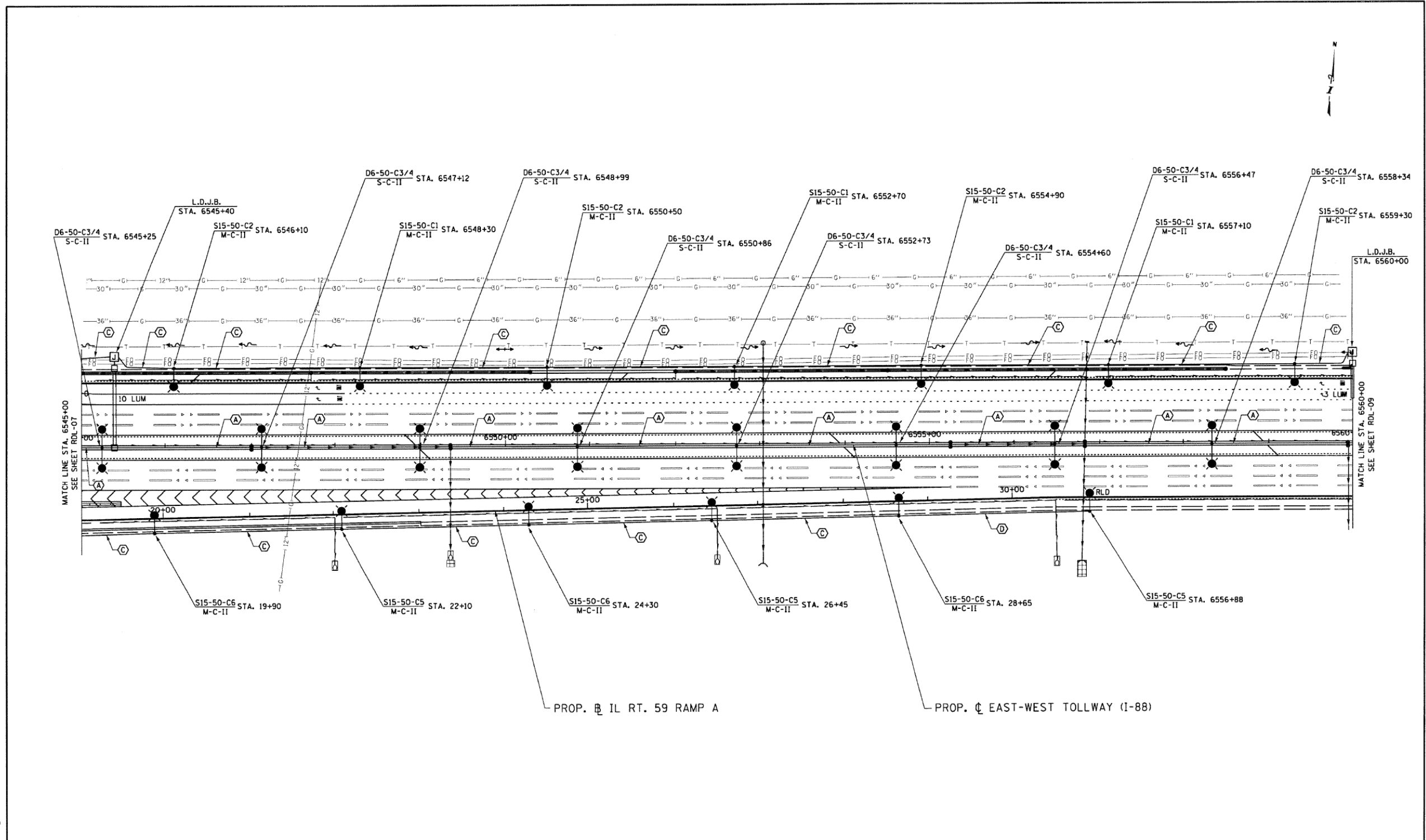

NOTES:  
1. SEE SHEET RDL-01 FOR ELECTRICAL SYMBOLS AND LEGEND.

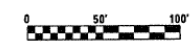

RDL-08

DRAWN BY JDM SCALE 1"=50'  
CHECKED BY SM DATE 3/1/05

**K&E** KAM ENGINEERING, INC.  
CONSULTING ENGINEERS  
707A Davis Road, Suite 205  
Elgin, Illinois 60123-1369

**THE ILLINOIS STATE TOLL HIGHWAY AUTHORITY**  
2700 OGDEN AVENUE  
DOWNERS GROVE, ILLINOIS 60515

REVISIONS		
NO.	DATE	DESCRIPTION
1	3/01/05	NEW SHEET

CONTRACT NO. RR-04-5198	DRAWING NO.
PROPOSED LIGHTING PLAN	279 OF 601

FOR INFORMATION ONLY

FILE NAME =	USER NAME = #USER#	DESIGNED MCP	REVISED -	<b>STATE OF ILLINOIS DEPARTMENT OF TRANSPORTATION</b>	<b>EXISTING LIGHTING PLAN (FOR REFERENCE)</b>	F.A.P. RTE.	SECTION	COUNTY	TOTAL SHEETS	SHEET NO.
#FILEL#		DRAWN MLB	REVISED -			338	(112 & 113) WRS-5	DUPAGE	963	582
PLOT SCALE = #SCALE#		CHECKED MCP	REVISED -			<b>LT-27</b>		CONTRACT NO. 60131		
PLOT DATE = #DATE#		DATE 10/15/2012	REVISED -			SCALE: AS SHOWN	SHEET NO. 7 OF 9 SHEETS	STA. 4038+00	TO STA. 4044+00	

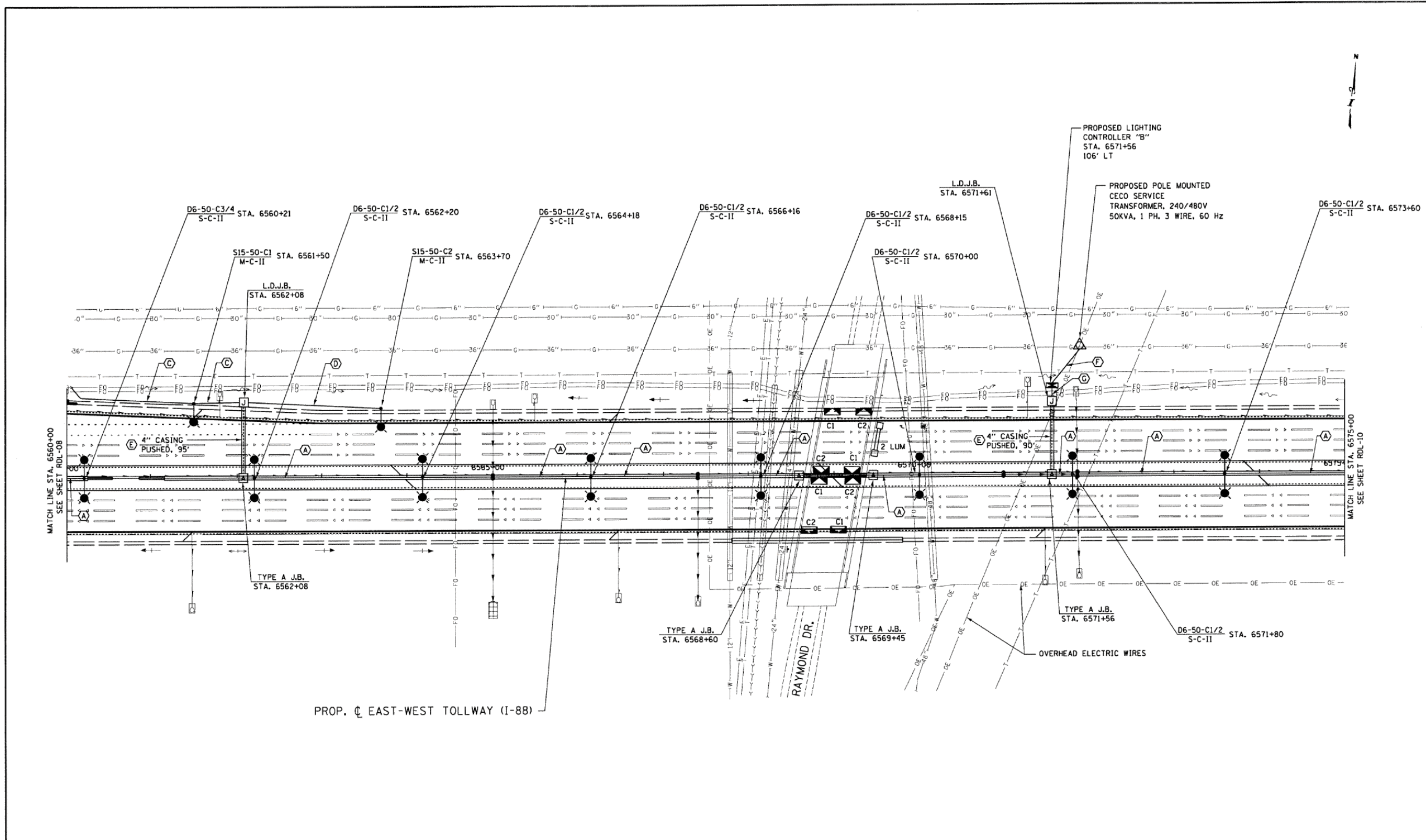

NOTES:  
 1. SEE SHEET RDL-01 FOR ELECTRICAL SYMBOLS AND LEGEND.

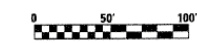

RDL-09

DRAWN BY JDM SCALE 1"=50'  
 CHECKED BY SM DATE 3/1/05

**K&E** KAM ENGINEERING, INC.  
 CONSULTING ENGINEERS  
 707A Davis Road, Suite 205  
 Elgin, Illinois 60123-1369

**THE ILLINOIS STATE TOLL HIGHWAY AUTHORITY**  
 2700 OGDEN AVENUE  
 DOWNERS GROVE, ILLINOIS 60515

REVISIONS		
NO.	DATE	DESCRIPTION
1	3/01/05	NEW SHEET

CONTRACT NO. RR-04-5198  
 PROPOSED LIGHTING PLAN

DRAWING NO.  
 280 OF 601

FOR INFORMATION ONLY

FILE NAME =	USER NAME = \$USER*	DESIGNED MCP	REVISED -
\$FILEL\$		DRAWN MLB	REVISED -
	PLOT SCALE = \$SCALE*	CHECKED MCP	REVISED -
	PLOT DATE = \$DATE*	DATE 10/15/2012	REVISED -

**STATE OF ILLINOIS**  
**DEPARTMENT OF TRANSPORTATION**

**EXISTING LIGHTING PLAN**  
**(FOR REFERENCE)**

SCALE: AS SHOWN SHEET NO. 8 OF 9 SHEETS STA. 4038+00 TO STA. 4044+00

F.A.P. RTE.	SECTION	COUNTY	TOTAL SHEETS	SHEET NO.
338	(112 & 113) WRS-5	DUPAGE	963	583
<b>LT-28</b>			CONTRACT NO. 60131	
ILLINOIS FED. AID PROJECT				

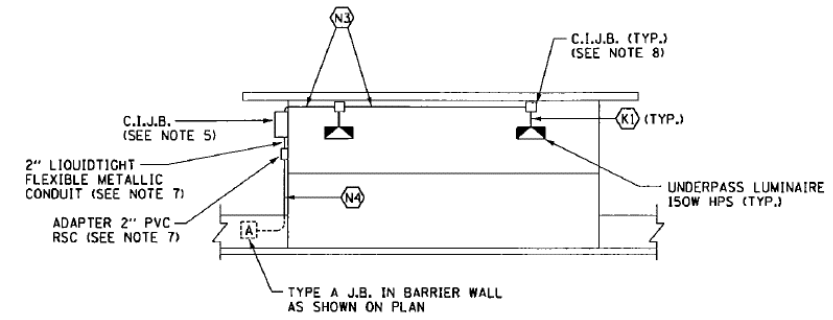
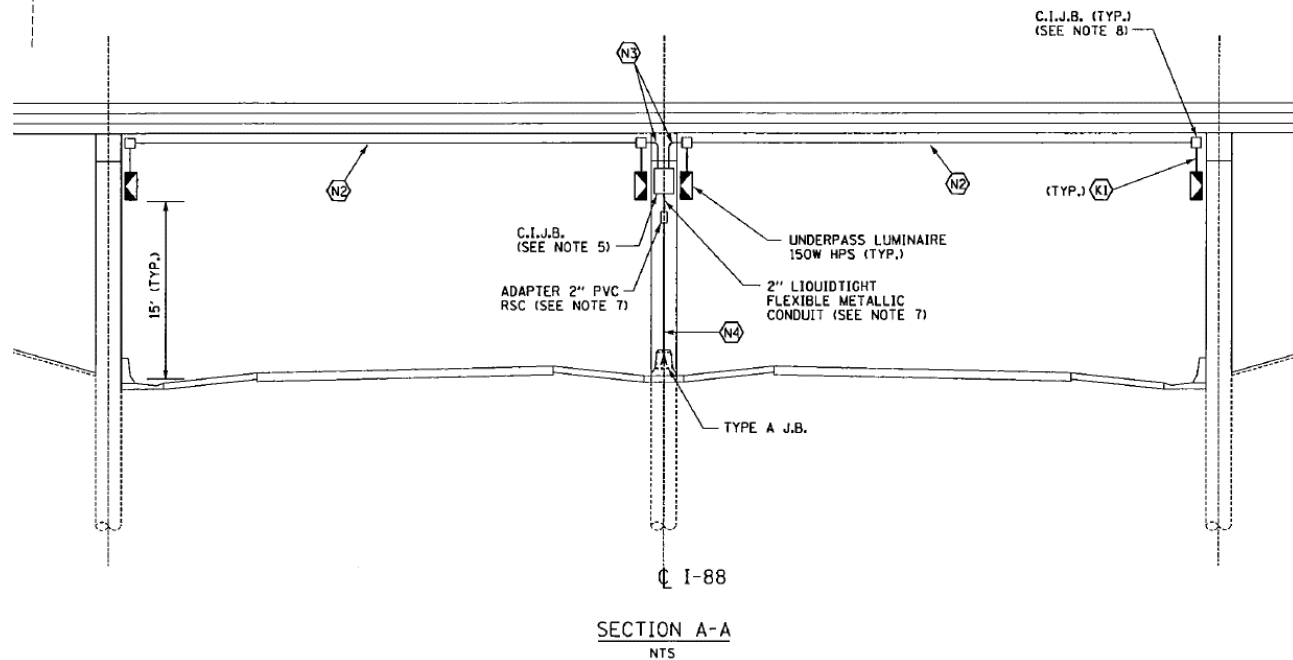
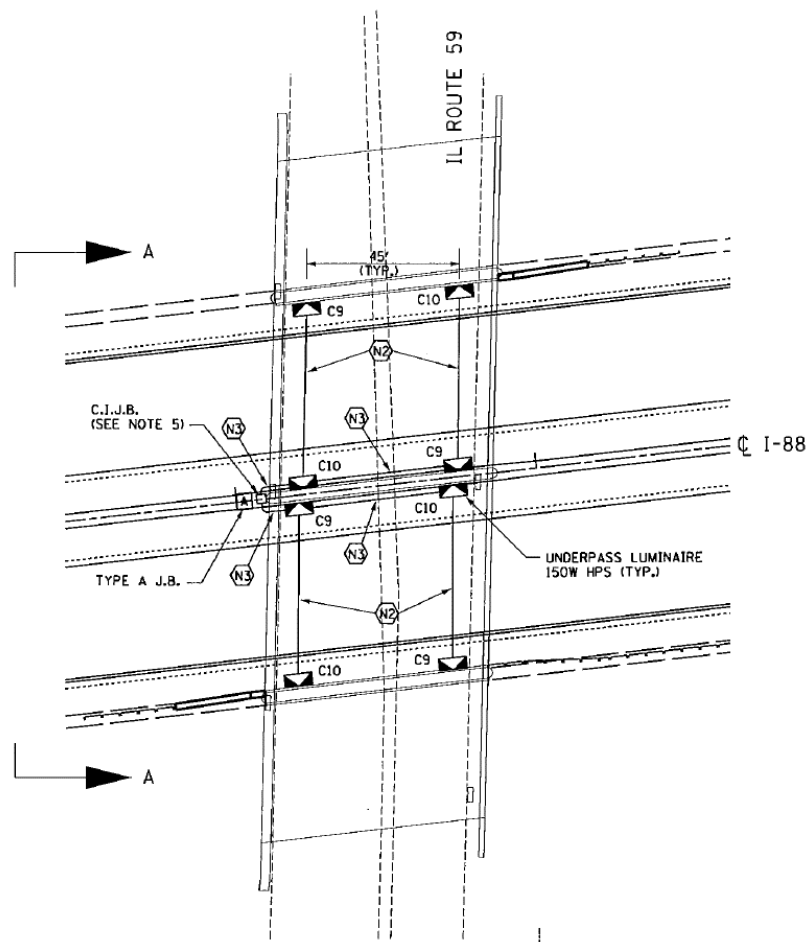

**CABLE GROUPING LEGEND**

- (K1) 3/4" PVC COATED RGS CONDUIT, 2 \*10 AND 1 \*10 GROUND (ALL 600V TYPE XHHW) ATTACHED TO STRUCTURE
- (N2) 1" PVC COATED RGS CONDUIT, 2 \*10 AND 1 \*10 GROUND (ALL 600V TYPE XHHW) ATTACHED TO STRUCTURE
- (N3) 1" PVC COATED RGS CONDUIT, 4 \*10 AND 1 \*10 GROUND (ALL 600V TYPE XHHW) ATTACHED TO STRUCTURE
- (N4) 2" PVC COATED RGS CONDUIT, 4 \*10 AND 1 \*10 GROUND (ALL 600V TYPE XHHW) ATTACHED TO STRUCTURE

**NOTES:**

1. EXPANSION FITTINGS SHALL BE FURNISHED AND INSTALLED IN CONDUIT RUNS AT ALL STRUCTURAL EXPANSION JOINTS.
2. PVC COATED CONDUIT CLAMP AND CLAMP BACK ON 5'-0" CENTERS, (TYPICAL) ATTACH WITH EXPANSION ANCHORS (MIN. 2" LONG) EXPANSION ANCHORS SHALL BE HOT DIPPED GALVANIZED AS MADE BY PARABOLT KWIK-BOLT OR WEJ-IT.
3. EXPANSION FITTINGS AT WALL JOINTS SHALL BE O.Z. GEDNEY TYPE DX EXPANSION-DEFLECTION FITTINGS OR APPROVED EQUAL ALLOWING A MOVEMENT OF 3/4" IN ALL DIRECTIONS AND A DEFLECTION OF 30° FROM NORMAL IN ALL DIRECTIONS.
4. ALL 5-KV CABLE IN CABLE DUCT SHALL BE TESTED PRIOR TO CONNECTING ANY 600 VOLT CABLE SERVING THE WALL MOUNTED LIGHTING.
5. 12"X8"X6" CAST IRON (C.I.) JUNCTION BOX WITH 4 BUSS HEB RCL-A "TRON" IN-LINE FUSE HOLDERS & FUSES FOR WALL MOUNTED LUMINAIRE CIRCUITS, FUSES & HOLDERS WILL BE CONSIDERED AS INCIDENTAL TO C.I.J.B. (12"X8"X6").
6. LUMINAIRES SHALL BE SURFACE MOUNTED TO WALL WITH LUMISTRUT P5500 STAINLESS STEEL CHANNELS (1/2 GAUGE) TO PROVIDE A MINIMUM CLEARANCE OF 2" BETWEEN THE BACK OF LUMINAIRE AND THE FACE OF THE WALL.
7. CONDUIT CONTAINS 4 \*10 AND 1 \*10 GROUND (ALL 600V TYPE XHHW). FITTING AND LIQUIDTIGHT METALLIC CONDUIT ARE INCIDENTAL TO C.I.J.B. (12"X8"X6"), NO ADDITIONAL COMPENSATION WILL BE ALLOWED.
8. CAST IRON JUNCTION BOX (C.I.J.B.), 4"X4"X3".
9. LOCATE CENTERLINE OF 45' LUMINAIRE SPACING AT CENTERLINE OF ILLINOIS ROUTE 59 OVERPASS.

RD-35

DRAWN BY JDM SCALE NONE  
CHECKED BY SM DATE 3/1/05

**K&E** KAM ENGINEERING, INC.  
CONSULTING ENGINEERS  
707A Davis Road, Suite 205  
Elgin, Illinois 60123-1369

**THE ILLINOIS STATE TOLL HIGHWAY AUTHORITY**  
2700 OGDEN AVENUE  
DOWNERS GROVE, ILLINOIS 60515

REVISIONS		
NO.	DATE	DESCRIPTION
1	3/01/05	NEW SHEET

CONTRACT NO. RR-04-5198  
UNDERPASS LIGHTING  
I-88 UNDER IL RT 59

DRAWING NO.  
306 OF 601

FOR INFORMATION ONLY

FILE NAME =	USER NAME = #USER*	DESIGNED MCP	REVISED -
#FILE#		DRAWN MLB	REVISED -
	PLOT SCALE = #SCALE*	CHECKED MCP	REVISED -
	PLOT DATE = #DATE*	DATE 10/15/2012	REVISED -

STATE OF ILLINOIS  
DEPARTMENT OF TRANSPORTATION

EXISTING LIGHTING PLAN  
(FOR REFERENCE)  
SCALE: AS SHOWN SHEET NO. 9 OF 9 SHEETS STA. 4038+00 TO STA. 4044+00

F.A.P. RTE.	SECTION	COUNTY	TOTAL SHEETS	SHEET NO.
338	(112 & 113) WRS-5	DUPAGE	963	584
<b>LT-29</b>			CONTRACT NO. 60131	
ILLINOIS FED. AID PROJECT				

Bench Mark: BM #224 4059+52, 34 ft LT DuPage County Survey Disc at north end of the west bridge wall.  
IL Route 59 over Interstate Route 88. Elev. 731.43

Existing Structure: SN 022-9900 (Tollway BN 825) built in 1957 at Sta. 7167+66.30 by the Illinois State Toll Highway Commission as Bridge No. E1-14. Widened to the west in 1980 as F.A. Route 108 Section E-1-14 BY-R(80) by the Illinois Department of Transportation. Structure consists of four span PPC I-beams (10-48", 2-42") on stub abutment supported on concrete piles and drilled shaft piers. 226'-11" back-to-back abutments. 73'-11" out-to-out deck. Structure to be removed and replaced using stage construction.

No salvage

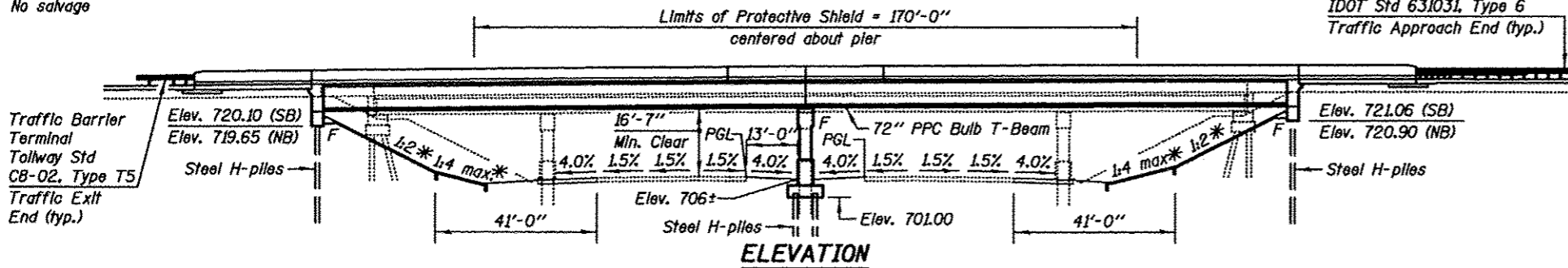

**DESIGN SPECIFICATIONS**  
2010 AASHTO LRFD Bridge Design Specifications, 5th Edition, with 2010 Interim Revisions  
Illinois State Toll Highway Authority  
Structure Design Manual, March 2012

**LOADING HL 93**  
Allow 50#/sq. ft. for future wearing surface.

**DESIGN STRESSES**  
**FIELD UNITS**  
f<sub>c</sub> = 3,500 psi  
f<sub>y</sub> = 60,000 psi (reinforcement)  
f<sub>y</sub> = 50,000 psi (AASHTO M270 Gr. 50)

**PRECAST PRESTRESSED UNITS**  
f<sub>c</sub> = 7,000 psi  
f<sub>ci</sub> = 5,200 psi  
f<sub>pu</sub> = 270,000 psi (1/2" low lax strands)  
f<sub>pb</sub> = 201,960 psi (1/2" low lax strands)

**APPROVED**  
For Structural Adequacy Only  
*D. Carl Perry, P.E.*  
Engineer of Bridges & Structures

**SEISMIC DATA**  
Seismic Performance Zone (SPZ) = 1  
Design Spectral Acceleration at 1.0 sec. (S<sub>d1</sub>) = 0.086g  
Design Spectral Acceleration at 0.2 sec. (S<sub>d5</sub>) = 0.158g  
Soil Site Class = D

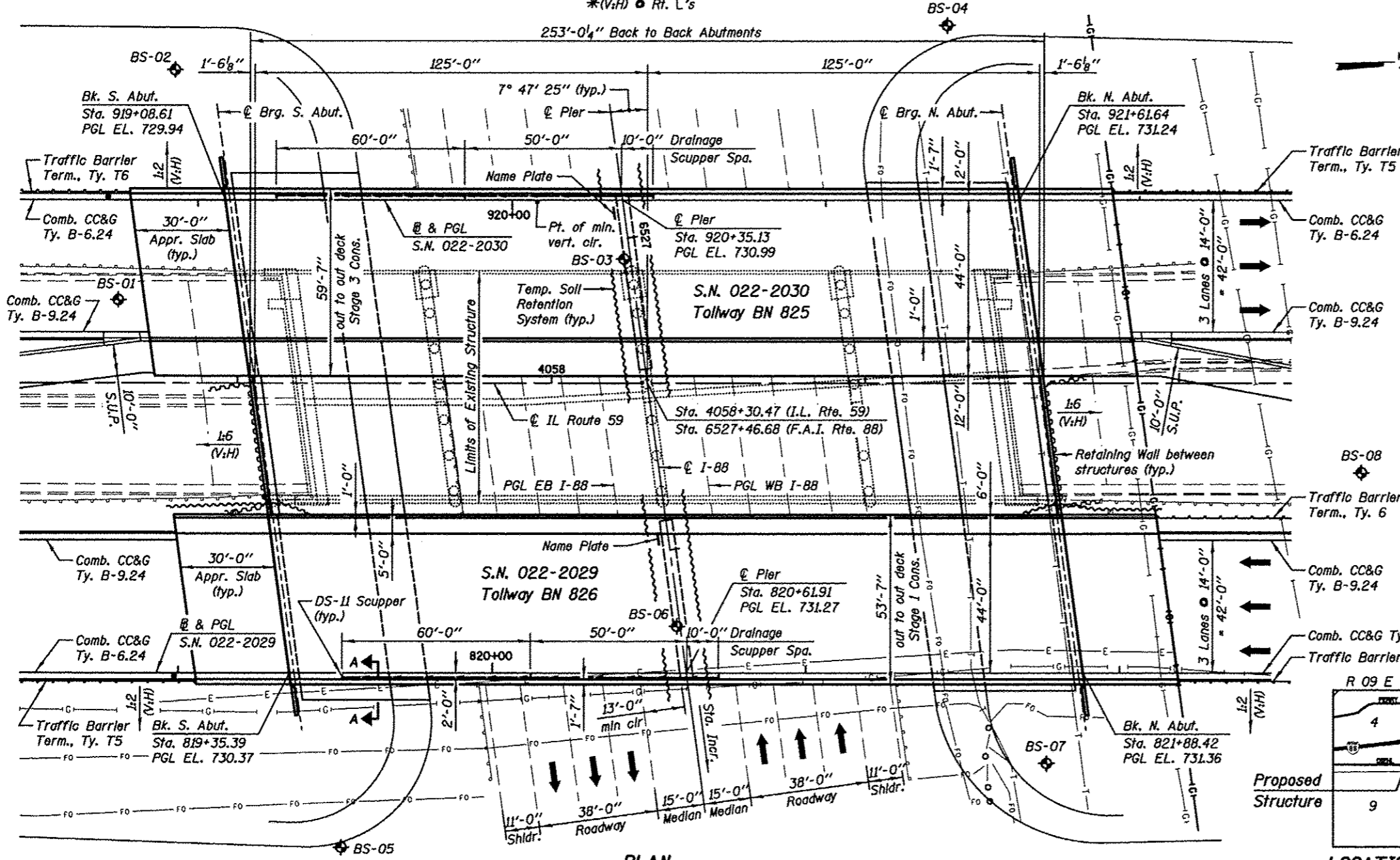

Expire 11-30-2014  
Date: 11/08/2012  
for drawings SA-01 thru SA-63

STATION 4058+30.47  
BUILT 20 BY  
STATE OF ILLINOIS  
F.A.P. RTE. 338 SEC. (112 & 113) WRS-5  
LOADING HL-93  
STRUCTURE NO. 022-2029

STATION 4058+30.47  
BUILT 20 BY  
STATE OF ILLINOIS  
F.A.P. RTE. 338 SEC. (112 & 113) WRS-5  
LOADING HL-93  
STRUCTURE NO. 022-2030

**NAME PLATES**  
See Std. 515001

**LEGEND**  
◆ Soil Borings  
F.F. Front Face NIC Not In Contract  
B.F. Back Face S.U.P. Shared Use Path

**Notes:**  
S.N. 022-2029 and S.N. 022-2030 are part of a Diverging Diamond Interchange (DDI).

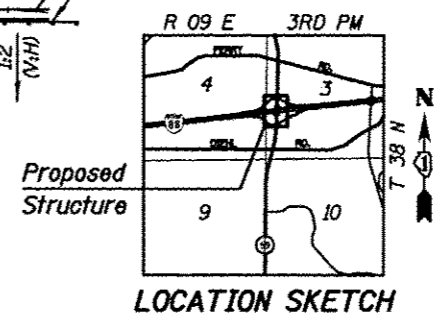

**GENERAL PLAN AND ELEVATION**  
ILLINOIS ROUTE 59 OVER I-88  
F.A.P. RTE. 338 SEC. (112 & 113) WRS-5  
DUPAGE COUNTY  
STATION 4058+30.47  
S.N. 022-2029 (SB) TOLLWAY B.N. 826  
S.N. 022-2030 (NB) TOLLWAY B.N. 825

<b>KNIGHT</b> Engineers & Architects	DESIGNED - WPM	REVISD	STATE OF ILLINOIS DEPARTMENT OF TRANSPORTATION	GENERAL PLAN AND ELEVATION S.N. 022-2029 (SB) TOLLWAY B.N. 826 S.N. 022-2030 (NB) TOLLWAY B.N. 825 SHEET NO. SA-01 OF 63 SHEETS	F.A.P. RTE.	SECTION	COUNTY	TOTAL SHEETS	SHEET NO.
	CHECKED - TB	REVISD			338	(112 & 113) WRS-5	DUPAGE	963	585
	SCALE - NONE	REVISD			CONTRACT NO. 60131				
	DATE - 10/15/2012	REVISD			ILLINOIS FED. AID PROJECT				

**GENERAL NOTES**

Fasteners shall be ASTM A325 Type 1, mechanically galvanized bolts. Bolts 3/4 in. dia., holes 5/16 in. dia., unless otherwise noted.

Reinforcement bars designated (E) shall be epoxy coated.

The embankment configuration shown shall be the minimum that must be placed and compacted prior to construction of the abutments and bridge approach slabs.

All exposed concrete edges shall have a 3/4" x 45° chamfer, except where shown otherwise. Chamfer on vertical edges shall be continued a minimum of one foot below finished ground level.

Reinforcement bar bending details shall be in accordance with the latest "Manual of Standard Practice for Detailing Reinforced Concrete Structures", ACI 315.

Cover from the face of concrete to face of reinforcement bars shall be 3 inches for surfaces formed against earth and 2 inches for all other surfaces unless otherwise shown.

Reinforcement bar bending dimensions are out to out.

Bridge seat reinforcement shall be carefully placed to avoid interference with drilling holes for anchor rods. The beams shall be erected in final position prior to drilling holes for and placing anchor rods.

Contractor shall not scale dimensions from the Contract Plans for construction purposes. Scales shown are for information only.

No construction joints except those shown on the plans will be allowed unless approved by the Engineer.

The Contractor may request copies of existing construction plans that are currently on file with the Tollway. The request shall be in writing with the understanding that any reproduction cost will be at the Contractors expense.

No concrete cutting will be permitted until the cutting limits have been outlined by the Contractor and approved by the Engineer.

It shall be the Contractor's responsibility to verify the location of all utilities prior to starting construction. Contact J.U.L.I.E., 800-892-0123.

Concrete sealer shall be applied to all exposed surfaces of piers.

If the Contractor elects to use cantilever forming brackets on the exterior beams or girders, the brackets shall be placed at the same locations as required for the hardwood blocks in Article 503.06(b) of the Standard Specifications. If additional cantilever forming brackets are required, hardwood blocking shall be wedged between the exterior and first interior beam at each of these additional bracket locations.

It shall be the Contractor's responsibility to verify the location of all fiber optic utilities prior to starting construction. The Contractor shall initiate the location process for the fiber optic cable by completing a "Request Tollway Utilities Locate" form filled in online at the Tollway website under "Doing Business" at least four (4) business days prior to starting any underground operations, excavations or digging of any type in the general area of the fiber optic cable.

The Contractor shall use care when excavating around existing foundations. Any damage to the existing structure and/or supporting foundation shall be repaired or replaced at the Contractor's expense.

Temporary soil retention systems, sheeting, bracing or cofferdams shall be constructed at the locations shown on the plans and/or as required for the excavation to protect the adjacent areas from settling or falling into the excavated areas.

The manufacturer, the Contractor and the beam transportation company shall provide adequate bracing and support for the PPC beams during handling, transporting, storing and erecting to ensure the safety of the personnel associated with the construction of the project.

After the beams are set, all elevations for determining fillet heights shall be taken at one time.

Upon completion of each structure, the Contractor shall measure the resulting horizontal and vertical clearances and submit them to the Engineer for review and inclusion in the As Built plans (Record Drawings).

The soil boring logs represent point information. Presentation of this information in no way implies that subsurface conditions are the same at locations other than the exact location of the boring.

Whenever any material is deposited into a drainage system or drainage structures, that deposited material shall be removed at the close of each working day. At the conclusion of construction operations, all drainage systems and structures shall be free from dirt and debris deposited during the various construction operations. The work specified above will not be paid for separately, but shall be considered included in the cost of cleaning of existing scuppers and drain pipes.

The Protective Shield shall extend as shown on Sheet SA-01 and as a minimum 2 ft beyond the existing and proposed edge of deck. As a minimum, the following will be required:  
 Stage 1 (Total = 1150 Sq. Yd.)  
 1150 Sq. Yd. to construct the proposed structure 022-2029  
 Stage 3 (Total = 2820 Sq. Yd.)  
 1550 Sq. Yd. to remove the existing structure  
 1270 Sq. Yd. to construct the proposed structure 022-2030

**INDEX OF SHEETS**

- SA-01 General Plan and Elevation
- SA-02 General Notes and Total Bill Of Material
- SA-03 Slope wall and Temporary Soil Retention System
- SA-04 Substructure Layout
- SA-05 Pile Driving Logs
- SA-06 Pile Driving Logs
- SA-07 Stage Construction Details
- SA-08 Temporary Concrete Barrier
- SA-09 Top of Slab Elevations (SB)
- SA-10 Top of Slab Elevations (SB)
- SA-11 Top of Slab Elevations (SB)
- SA-12 Top of Slab Elevations (SB)
- SA-13 Top of Slab Elevations (NB)
- SA-14 Top of Slab Elevations (NB)
- SA-15 Top of Slab Elevations (NB)
- SA-16 Top of Slab Elevations (NB)
- SA-17 Top of Slab Elevations (NB)
- SA-18 Top of Approach Slab Elevations (SB)
- SA-19 Top of Approach Slab Elevations (NB)
- SA-20 Deck Plan and Cross Section (SB)
- SA-21 Sidewalk and Parapet Details (SB)
- SA-22 East Parapet Details (SB)
- SA-23 Deck Diaphragm Details (SB)
- SA-24 Deck Miscellaneous Details (SB)
- SA-25 Deck Plan and Cross Section (NB)
- SA-26 Shared Use Path and Parapet Details (NB)
- SA-27 West Parapet Details (NB)
- SA-28 Deck Diaphragm Details (NB)
- SA-29 Deck Miscellaneous Details (NB)
- SA-30 Bridge Approach Slab Plan (SB)
- SA-31 Bridge Approach Slab Details (SB)
- SA-32 Bridge Approach Slab Details (SB)
- SA-33 Bridge Approach Slab Plan (NB)
- SA-34 Bridge Approach Slab Details (NB)
- SA-35 Bridge Approach Slab Details (NB)
- SA-36 Drainage Scupper, DS-11
- SA-37 Deck Drainage System
- SA-38 Bridge Fence Railing, Parapet Mounted
- SA-39 Bridge Fence Railing, Sidewalk Mounted
- SA-40 Framing Plan (SB)
- SA-41 Framing Plan (NB)
- SA-42 72" PPC Bulb T-Beam
- SA-43 72" PPC Bulb T-Beam Details
- SA-44 South Abutment (SB)
- SA-45 North Abutment (SB)
- SA-46 South Abutment (NB)
- SA-47 North Abutment (NB)
- SA-48 Abutment Miscellaneous Details
- SA-49 Retaining Wall - South Abutment
- SA-50 Retaining Wall - North Abutment
- SA-51 Pier (SB)
- SA-52 Pier (NB)
- SA-53 Pier Details
- SA-54 HP Pile Details
- SA-55 Bar Splicer Assembly Details
- SA-56 Soil Boring Logs

**TOTAL BILL OF MATERIAL - IDOT**

ITEM	UNIT	SUPER	SUB	TOTAL
Removal Of Existing Structures	Each	0.55	-	0.55
Protective Shield	Sq. Yd.	3970.0	-	3970.0
Concrete Structures	Cu. Yd.	76.0	-	76.0
Concrete Superstructure	Cu. Yd.	1709.0	-	1709.0
Bridge Deck Grooving	Sq. Yd.	3062.0	-	3062.0
Protective Coat	Sq. Yd.	4433.0	-	4433.0
Reinforcement Bars, Epoxy Coated	Pound	393200	-	393200
Bar Splicers	Each	236	-	236
Bridge Fence Railing	Foot	251.0	-	251.0
Bridge Fence Railing (Sidewalk)	Foot	251.0	-	251.0
Parapet Railing	Foot	312.0	-	312.0
Name Plates	Each	-	2	2
Drainage Scuppers, DS-11	Each	6	-	6
Drainage System, No. 1	Each	1	-	1
Drainage System, No. 2	Each	1	-	1

**TOTAL BILL OF MATERIAL - TOLLWAY**

ITEM	UNIT	SUPER	SUB	TOTAL
Removal Of Existing Structures	Each	0.1	0.35	0.45
Structure Excavation	Cu. Yd.	-	1651.0	1651.0
Concrete Structures	Cu. Yd.	-	523.0	523.0
Concrete Encasement	Cu. Yd.	-	28.0	28.0
Furnishing And Erecting Precast Prestressed Concrete Bulb T-Beams 72"	Foot	4256.0	-	4256.0
Stud Shear Connectors	Each	-	468	468
Reinforcement Bars, Epoxy Coated	Pound	-	67160	67160
Slope Wall 4 Inch	Sq. Yd.	-	1747.0	1747.0
Furnishing Steel Piles HP14x73	Foot	-	5648.0	5648.0
Driving Piles	Foot	-	5514.0	5514.0
Test Pile Steel HP14x73	Each	-	6	6
Concrete Sealer	Sq. Ft.	-	4142.0	4142.0
Geocomposite Wall Drain	Sq. Yd.	-	315.0	315.0
Pipe Underdrains for Structures 4"	Foot	-	364.0	364.0
Temporary Soil Retention System	Sq. Ft.	-	1845.0	1845.0
Permanent Steel Sheet Piling	Sq. Ft.	-	4354.0	4354.0
Granular Backfill For Structures	Cu. Yd.	-	916.0	916.0

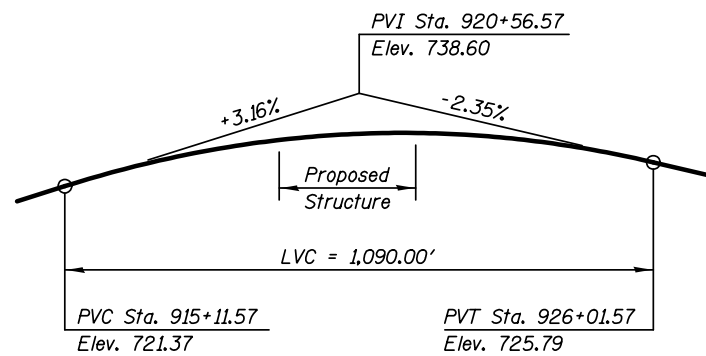

**Ⓜ NORTHBOUND IL 59 - PROPOSED PROFILE GRADE LINE**

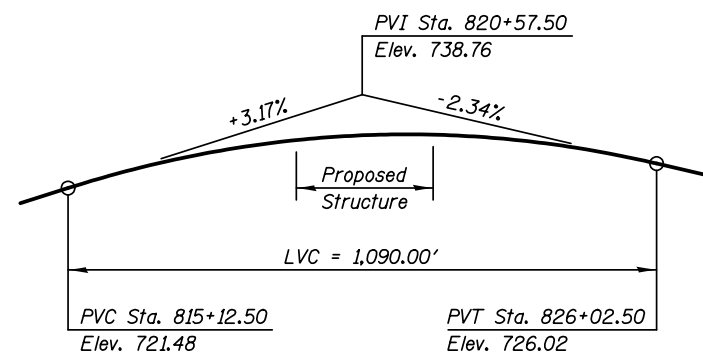

**Ⓜ SOUTHBOUND IL 59 - PROPOSED PROFILE GRADE LINE**

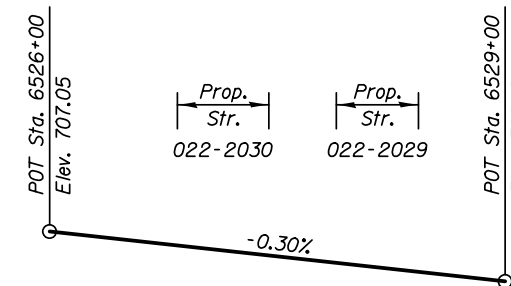

**I-88 E.B. & W.B. - EXISTING PROFILE GRADE LINE**

**KNIGHT**  
Engineers & Architects

DESIGNED - WPM	REVISIONS
CHECKED - TB	REVISIONS
SCALE - NONE	REVISIONS
DATE - 10/15/2012	REVISIONS
DRAWN - TB	REVISIONS
CHECKED - WPM	REVISIONS

STATE OF ILLINOIS  
DEPARTMENT OF TRANSPORTATION

GENERAL NOTES AND TOTAL BILL OF MATERIAL  
S.N. 022-2029 (SB) TOLLWAY B.N. 826  
S.N. 022-2030 (NB) TOLLWAY B.N. 825  
SHEET NO. SA-02 OF 63 SHEETS

F.A.P. RTE.	SECTION	COUNTY	TOTAL SHEETS	SHEET NO.
338	(112 & 113) WRS-5	DUPAGE	963	586
CONTRACT NO. 60131				
ILLINOIS FED. AID PROJECT				

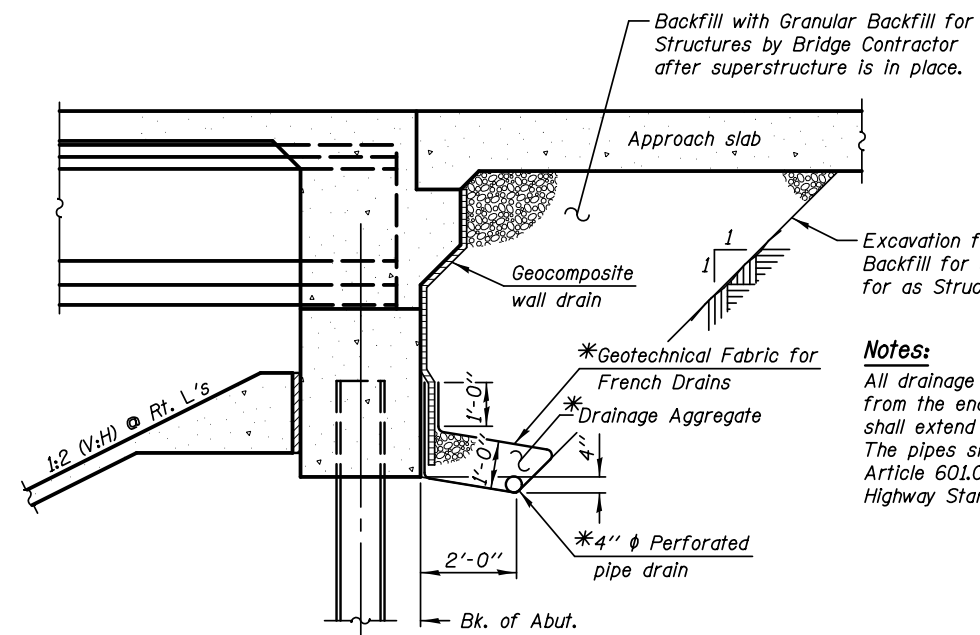

**SECTION THRU INTEGRAL ABUTMENT**  
(Horiz. dim. @ Rt. L's)

\*Included in the cost of Pipe Underdrains for Structures.

**Notes:**  
All drainage system components shall extend to 2'-0" from the end of each wingwall except an outlet pipe shall extend until intersecting with the side slopes. The pipes shall drain into concrete headwalls. (See Article 601.05 of the Standard Specifications and Highway Standard 601101).

**BILL OF MATERIAL**

Item	Unit	Quantity
Granular Backfill for Structures	Cu. Yd.	689.0
Pipe Underdrains for Structures 4"	Foot	284.0
Geocomposite Wall Drain	Sq. Yd.	315.0
Slope Wall 4 Inch	Sq. Yd.	1747.0
Temporary Soil Retention System	Sq. Ft.	1845.0

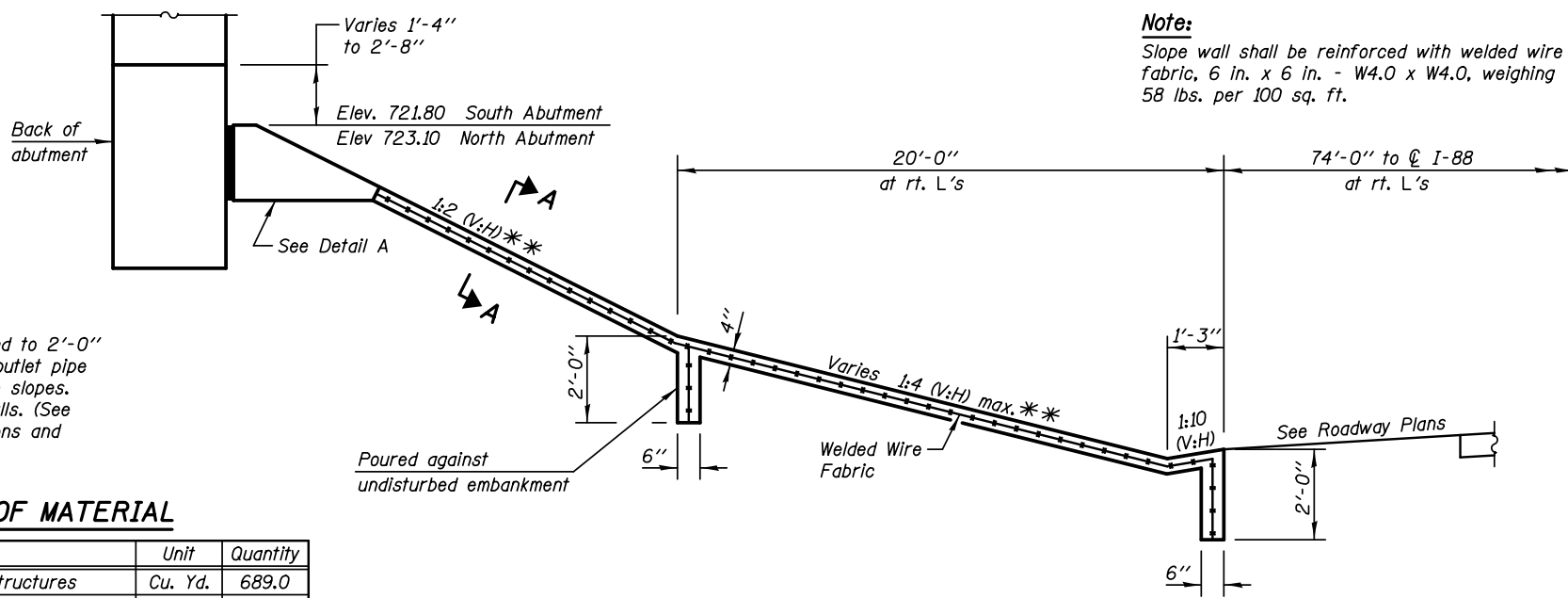

**SECTION THRU CONCRETE SLOPE WALL**  
\*\*at Rt. L's

**Note:**  
Slope wall shall be reinforced with welded wire fabric, 6 in. x 6 in. - W4.0 x W4.0, weighing 58 lbs. per 100 sq. ft.

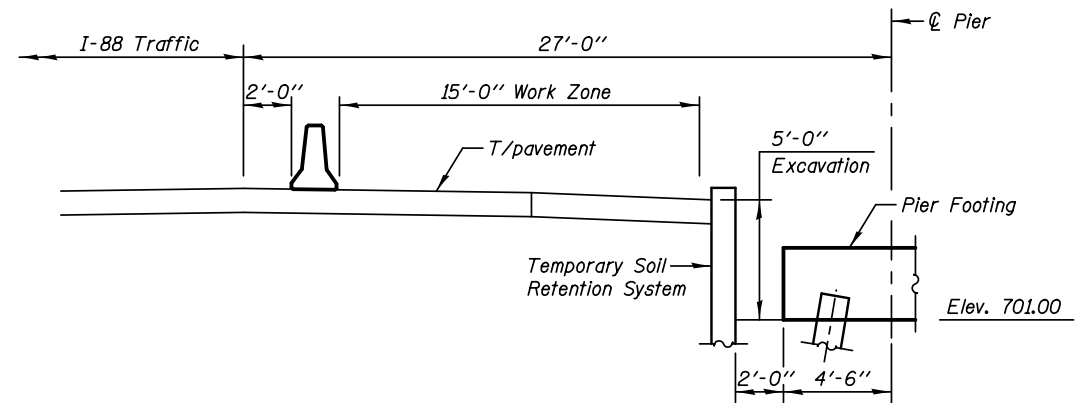

**TEMPORARY SOIL RETENTION SYSTEM - PIER DETAIL**  
(Symmetrical about C/Pier)

**Note:**  
A cantilevered sheet piling design does not appear feasible and additional members or other retention systems may be necessary. The Contractor shall submit a temporary soil retention system design including plan details and calculations for review and acceptance by the Engineer.

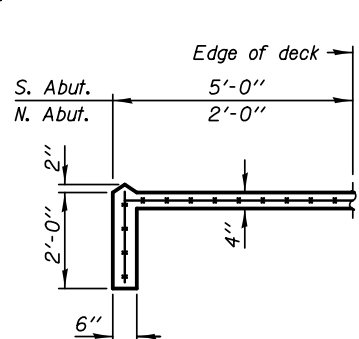

**SECTION A-A**

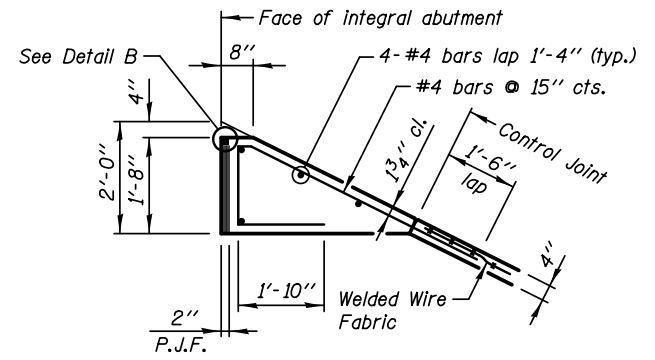

**DETAIL A**

Cost of #4 reinforcement bars included in the cost of Slope Wall 4 Inch.

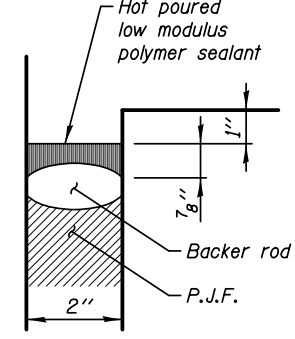

**DETAIL B**

**Note:**  
Sealant, backer rod and P.J.F. shall meet the requirements of Sections 1050 and 1051 of the Standard Specifications.

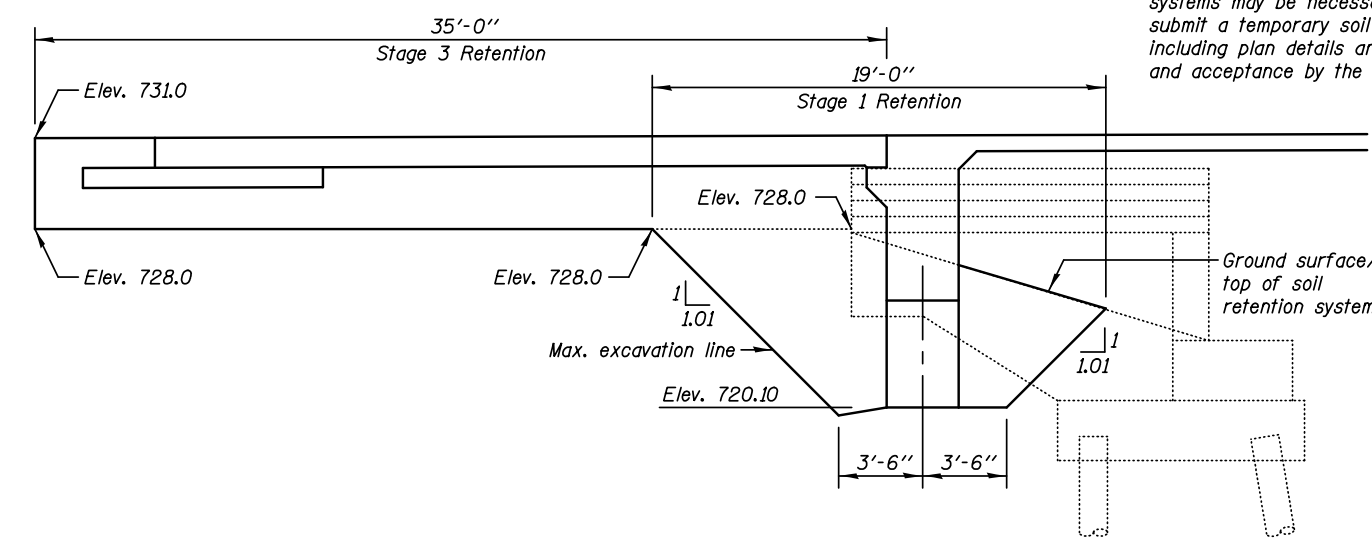

**TEMPORARY SOIL RETENTION SYSTEM - SOUTH ABUTMENT**  
(SB Bridge)

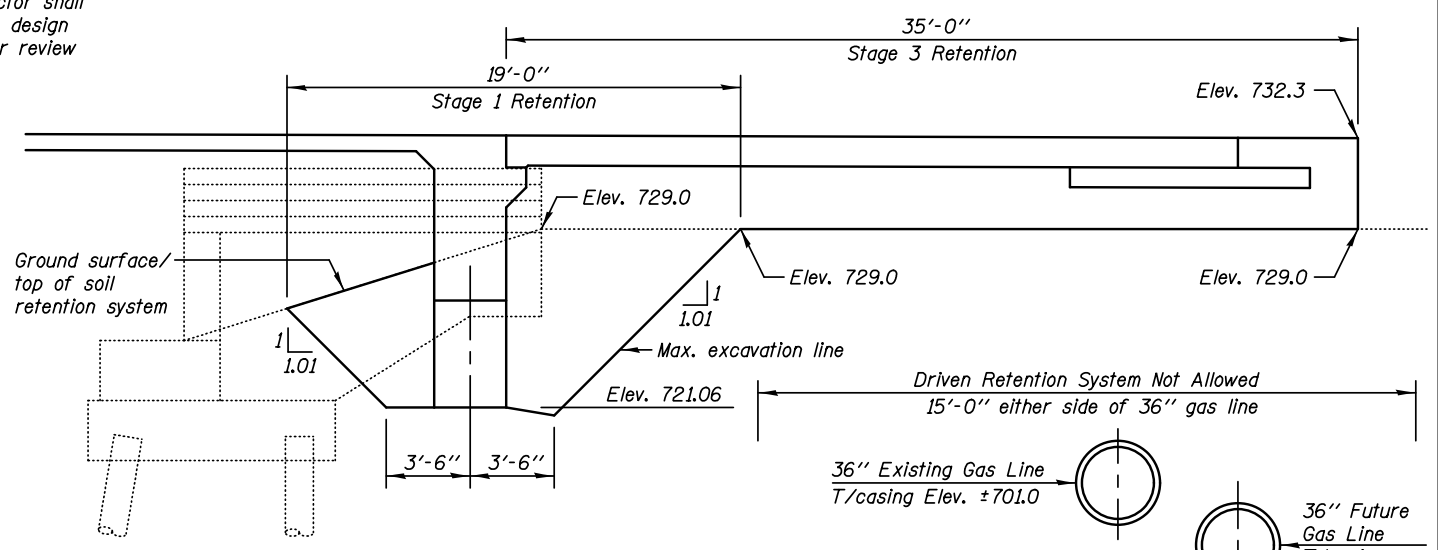

**TEMPORARY SOIL RETENTION SYSTEM - NORTH ABUTMENT**  
(SB Bridge)

**KNIGHT**  
Engineers & Architects

DESIGNED - WPM	REVISIONS
CHECKED - TB	REVISIONS
DRAWN - TB	REVISIONS
CHECKED - WPM	REVISIONS

STATE OF ILLINOIS  
DEPARTMENT OF TRANSPORTATION

**SLOPEWALL AND TEMPORARY SOIL RETENTION SYSTEM**  
S.N. 022-2029 (SB) TOLLWAY B.N. 826  
S.N. 022-2030 (NB) TOLLWAY B.N. 825  
SHEET NO. SA-03 OF 63 SHEETS

F.A.P. RTE.	SECTION	COUNTY	TOTAL SHEETS	SHEET NO.
338	(112 & 113) WRS-5	DUPAGE	963	587
CONTRACT NO. 60131				

ILLINOIS FED. AID PROJECT

253'-0 1/4" Bk. to Bk Abutments

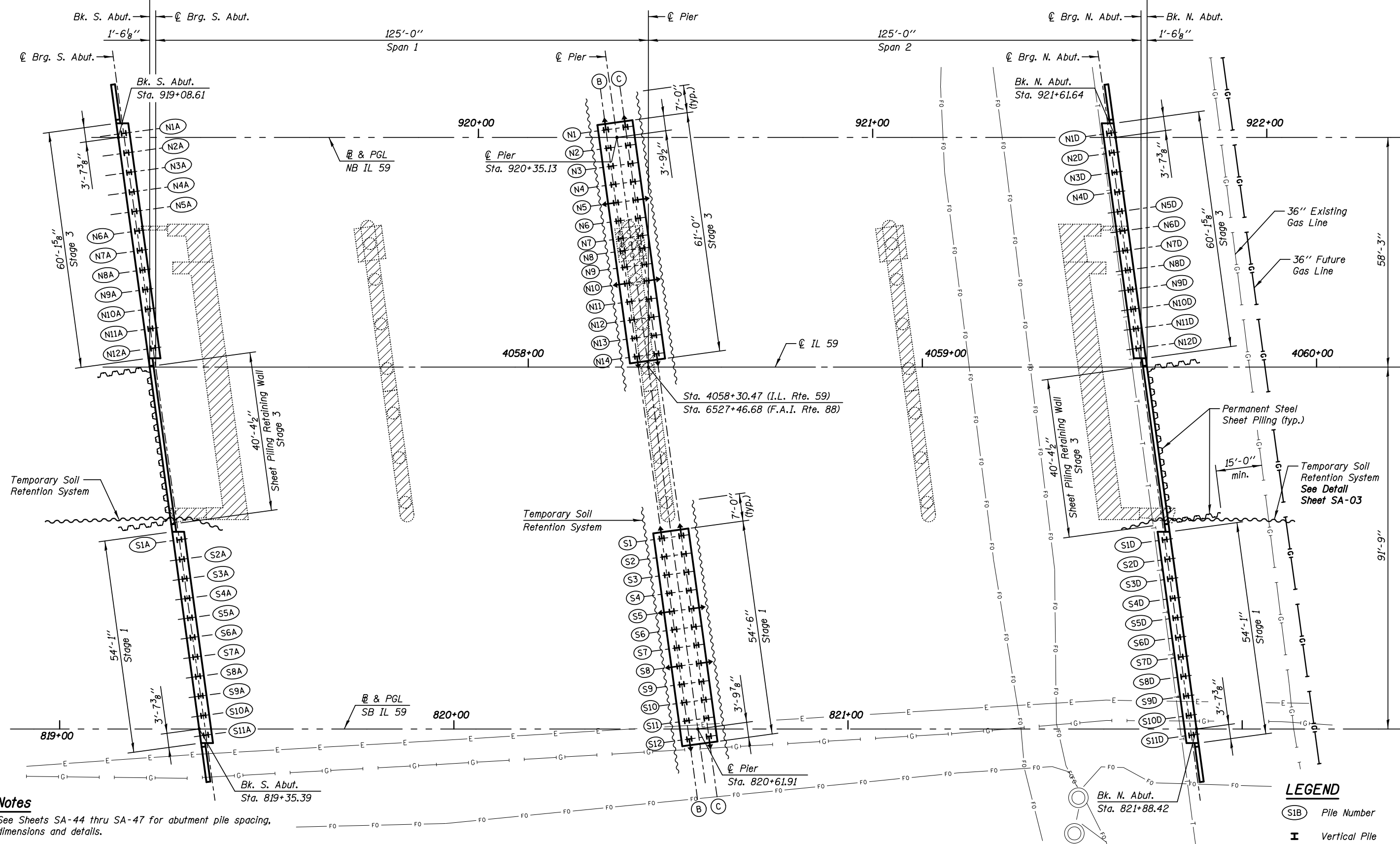
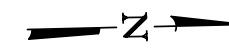

**Notes**

- See Sheets SA-44 thru SA-47 for abutment pile spacing, dimensions and details.
- See Sheets SA-51 and SA-52 for pier pile spacing, dimensions and details.
- See Sheets SA-49 and SA-50 for permanent steel sheet piling dimensions and details.
- See Sheet SA-03 for Temporary Soil Retention System details.
- See "Status of Utilities To Be Adjusted" and "Existing Utilities" Special Provisions.

**SUBSTRUCTURE LAYOUT**

**LEGEND**

- (S1B) Pile Number
- I Vertical Pile
- ⊕ Battered Pile
- ▨ Substructure Removal

<b>KNIGHT</b> Engineers & Architects	DESIGNED - WPM	REVISION	<b>STATE OF ILLINOIS</b> <b>DEPARTMENT OF TRANSPORTATION</b>	<b>SUBSTRUCTURE LAYOUT</b> S.N. 022-2029 (SB) TOLLWAY B.N. 826 S.N. 022-2030 (NB) TOLLWAY B.N. 825 SHEET NO. SA-04 OF 63 SHEETS	F.A.P. RTE.	SECTION	COUNTY	TOTAL SHEETS	SHEET NO.
	SCALE - NONE	CHECKED - TB			REVISION	338	(112 & 113) WRS-5	DUPAGE	963
DATE - 10/15/2012	DRAWN - TB	REVISION			CONTRACT NO. 60131				
	CHECKED - WPM	REVISION			ILLINOIS FED. AID PROJECT				



**PILE DRIVING RECORD**

Type & Size of Pile Used: \_\_\_\_\_

Formula Used To Calculate Capacity: \_\_\_\_\_

Pile Driving Equipment Used: \_\_\_\_\_ Energy Rating: \_\_\_\_\_

Pile Driving Contractor: \_\_\_\_\_

Hammer Used: Type \_\_\_\_\_ Stroke \_\_\_\_\_ Weight \_\_\_\_\_

CM: \_\_\_\_\_

Pile Location	Pile Number	Ground Surface Elevation	Cut-off Elevation	Penetrated Length In Feet	Driving Data For The Final 5 Ft. - Blows							Capacity In Tons	Date Pile Driven Month / Year	Remarks
					5' to 4'	4' to 3'	3' to 2'	3' to 2'	1' to 0'	12" to 6"*	6" to 0"*			
SB S. Abut.	S1A													
SB S. Abut.	S2A													
SB S. Abut.	S3A													
SB S. Abut.	S4A													
SB S. Abut.	S5A													
SB S. Abut.	S6A													
SB S. Abut.	S7A													
SB S. Abut.	S8A													
SB S. Abut.	S9A													
SB S. Abut.	S10A													
SB S. Abut.	S11A													
SB Pier	S1B													
SB Pier	S2B													
SB Pier	S3B													
SB Pier	S4B													
SB Pier	S5B													
SB Pier	S6B													
SB Pier	S7B													
SB Pier	S8B													
SB Pier	S9B													
SB Pier	S10B													
SB Pier	S11B													
SB Pier	S12B													
SB Pier	S1C													
SB Pier	S2C													
SB Pier	S3C													
SB Pier	S4C													
SB Pier	S5C													
SB Pier	S6C													
SB Pier	S7C													
SB Pier	S8C													
SB Pier	S9C													
SB Pier	S10C													
SB Pier	S11C													
SB Pier	S12C													
SB N. Abut.	S1D													
SB N. Abut.	S2D													
SB N. Abut.	S3D													
SB N. Abut.	S4D													
SB N. Abut.	S5D													
SB N. Abut.	S6D													
SB N. Abut.	S7D													
SB N. Abut.	S8D													
SB N. Abut.	S9D													
SB N. Abut.	S10D													
SB N. Abut.	S11D													

**Notes:**

\*For piles driven to refusal, blow count for the last foot shall be recorded in 6 inches increments.

Pile damage, obstruction, pile rejection, test piles etc. shall be recorded in Remarks column.

This sheet requires completion by the Engineer for its inclusion into the As Built Record Plans.

**PILE DRIVING RECORD**

Type & Size of Pile Used: \_\_\_\_\_

Formula Used To Calculate Capacity: \_\_\_\_\_

Pile Driving Equipment Used: \_\_\_\_\_ Energy Rating: \_\_\_\_\_

Pile Driving Contractor: \_\_\_\_\_

Hammer Used: Type \_\_\_\_\_ Stroke \_\_\_\_\_ Weight \_\_\_\_\_

CM: \_\_\_\_\_

Pile Location	Pile Number	Ground Surface Elevation	Cut-off Elevation	Penetrated Length In Feet	Driving Data For The Final 5 Ft. - Blows							Capacity In Tons	Date Pile Driven Month / Year	Remarks
					5' to 4'	4' to 3'	3' to 2'	3' to 2'	1' to 0'	12" to 6"*	6" to 0"*			
NB S. Abut.	N1A													
NB S. Abut.	N2A													
NB S. Abut.	N3A													
NB S. Abut.	N4A													
NB S. Abut.	N5A													
NB S. Abut.	N6A													
NB S. Abut.	N7A													
NB S. Abut.	N8A													
NB S. Abut.	N9A													
NB S. Abut.	N10A													
NB S. Abut.	N11A													
NB S. Abut.	N12A													
NB Pier	N1B													
NB Pier	N2B													
NB Pier	N3B													
NB Pier	N4B													
NB Pier	N5B													
NB Pier	N6B													
NB Pier	N7B													
NB Pier	N8B													
NB Pier	N9B													
NB Pier	N10B													
NB Pier	N11B													
NB Pier	N12B													
NB Pier	N13B													
NB Pier	N14B													
NB Pier	N1C													
NB Pier	N2C													
NB Pier	N3C													
NB Pier	N4C													
NB Pier	N5C													
NB Pier	N6C													
NB Pier	N7C													
NB Pier	N8C													
NB Pier	N9C													
NB Pier	N10C													
NB Pier	N11C													
NB Pier	N12C													
NB Pier	N13C													
NB Pier	N14C													
NB N. Abut.	N1D													
NB N. Abut.	N2D													
NB N. Abut.	N3D													
NB N. Abut.	N4D													
NB N. Abut.	N5D													
NB N. Abut.	N6D													
NB N. Abut.	N7D													
NB N. Abut.	N8D													
NB N. Abut.	N9D													
NB N. Abut.	N10D													
NB N. Abut.	N11D													
NB N. Abut.	N12D													

**Notes:**  
 \*For piles driven to refusal, blow count for the last foot shall be recorded in 6 inches increments.  
 Pile damage, obstruction, pile rejection, test piles etc. shall be recorded in Remarks column.  
 This sheet requires completion by the Engineer for its inclusion into the As Built Record Plans.

**LEGEND**

 Pre-Stage Removal

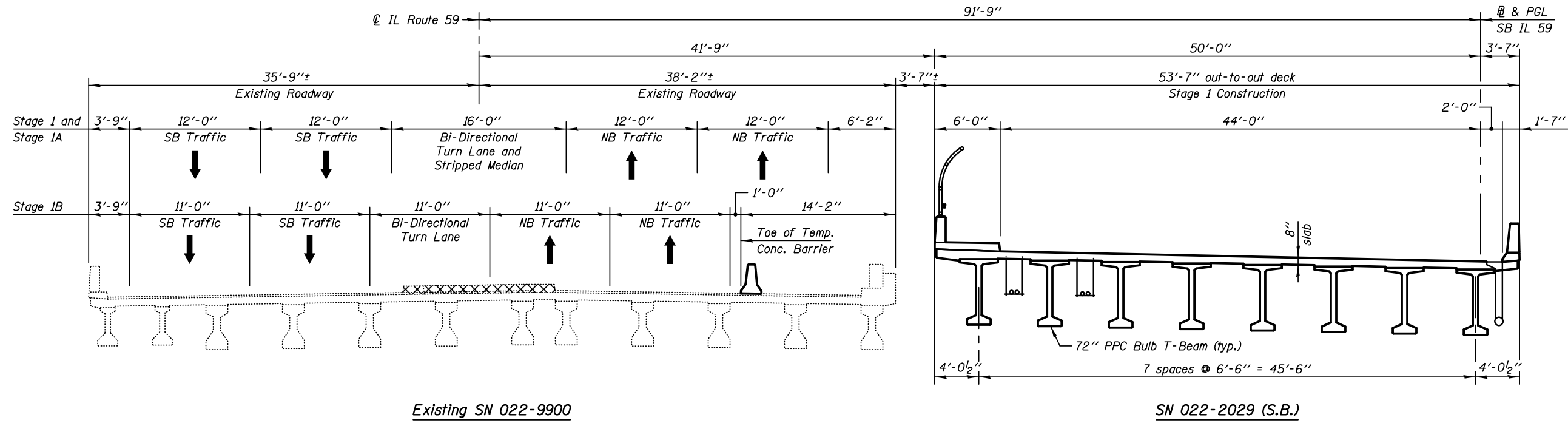

**STAGE 1 CONSTRUCTION**  
(Looking North)

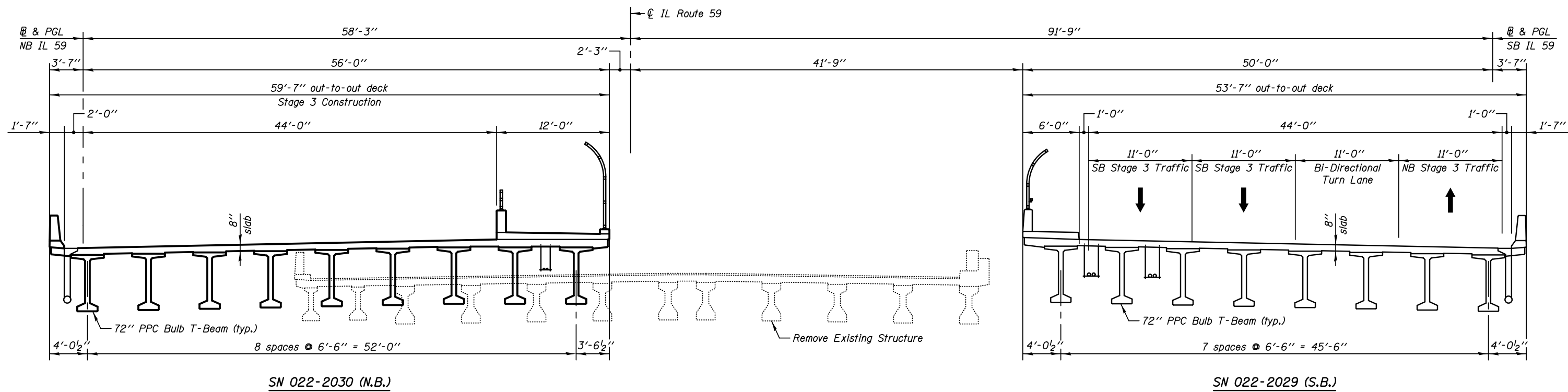

**STAGE 3 CONSTRUCTION**  
(Looking North)

**Notes:**

Stage 2 Construction consists of roadway work outside the limits of the structure.

See Roadway Plans for quantity of Temporary Concrete Barrier.

**KNIGHT**  
Engineers & Architects

DESIGNED - WPM	REVIS
CHECKED - TB	REVIS
DRAWN - TB	REVIS
CHECKED - WPM	REVIS
SCALE - NONE	
DATE - 10/15/2012	

STATE OF ILLINOIS  
DEPARTMENT OF TRANSPORTATION

**STAGE CONSTRUCTION DETAILS**  
S.N. 022-2029 (SB) TOLLWAY B.N. 826  
S.N. 022-2030 (NB) TOLLWAY B.N. 825  
SHEET NO. SA-07 OF 63 SHEETS

F.A.P. RTE.	SECTION	COUNTY	TOTAL SHEETS	SHEET NO.
338	(112 & 113) WRS-5	DUPAGE	963	591
CONTRACT NO. 60131				
ILLINOIS FED. AID PROJECT				

When "A" is 3'-6" or less, the temporary concrete barrier shall be anchored to the new slab according to Detail I or Detail II. No anchorage is required when "A" is greater than 3'-6".

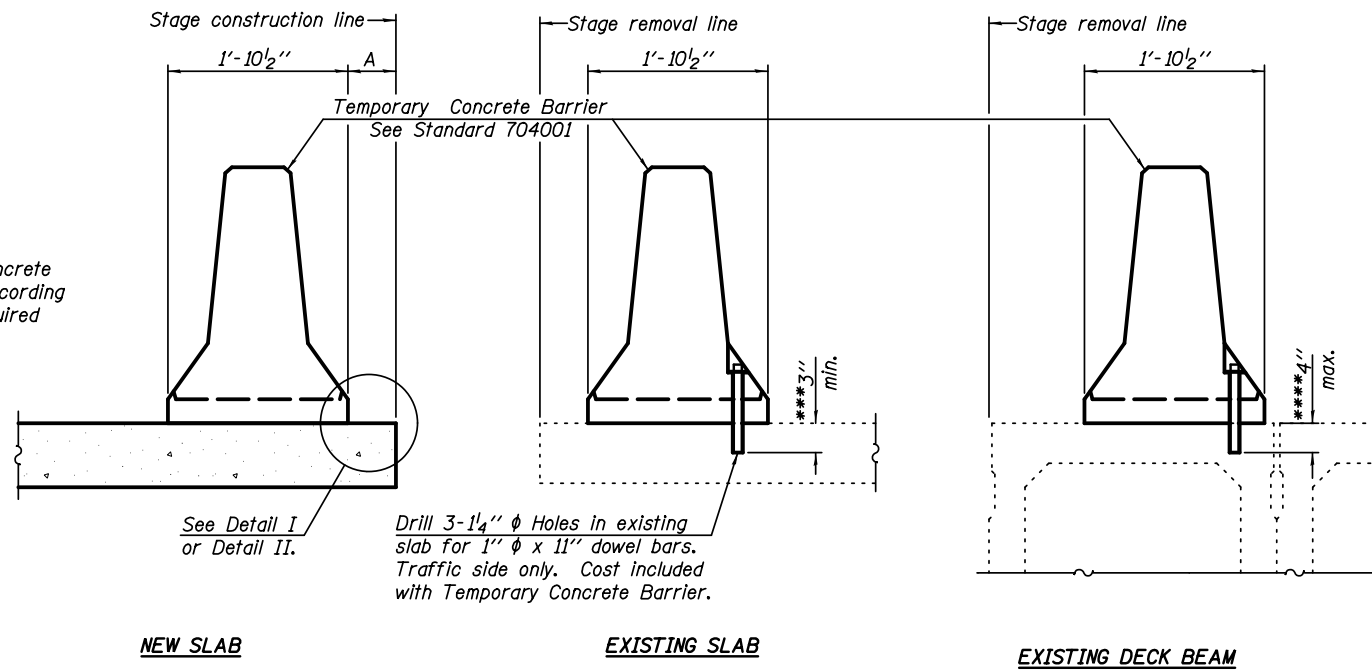

**SECTIONS THRU SLAB OR DECK BEAM**

**NOTES**

Detail I - With Bar Splicer or Couplers:  
Connect one (1) 1" x 7" x "W" steel PL to the top layer of couplers with 2-5/8" φ bolts screwed to coupler at approximate C of each barrier panel.

Detail II - With Extended Reinforcement Bars:  
Connect one (1) 1" x 7" x "W" steel PL to the concrete slab or concrete wearing surface with 2-5/8" φ Expansion Anchors or cast in place inserts spaced between the top layer of reinforcement at approximate C of each barrier panel.

Cost of anchorage is included with Temporary Concrete Barrier. The 1" x 7" x "W" plate shall not be removed until stage II construction forms and all reinforcement bars are in place and the concrete is ready to be placed.

\*\*\* Dimension shown is minimum required embedment into concrete.  
If hot-mix asphalt wearing surface is present, minimum embedment shall be in addition to wearing surface depth.

\*\*\*\* If existing deck beam is to remain in place after stage construction, embedment shall only be into wearing surface and not into existing deck beam concrete.

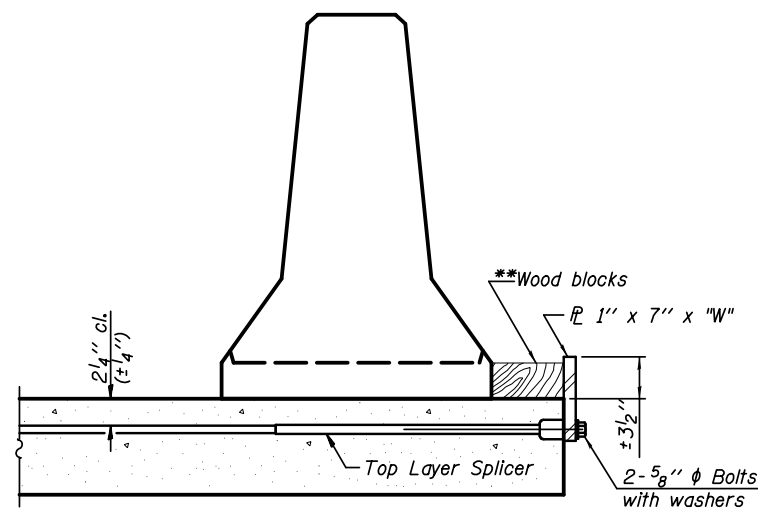

**DETAIL I**

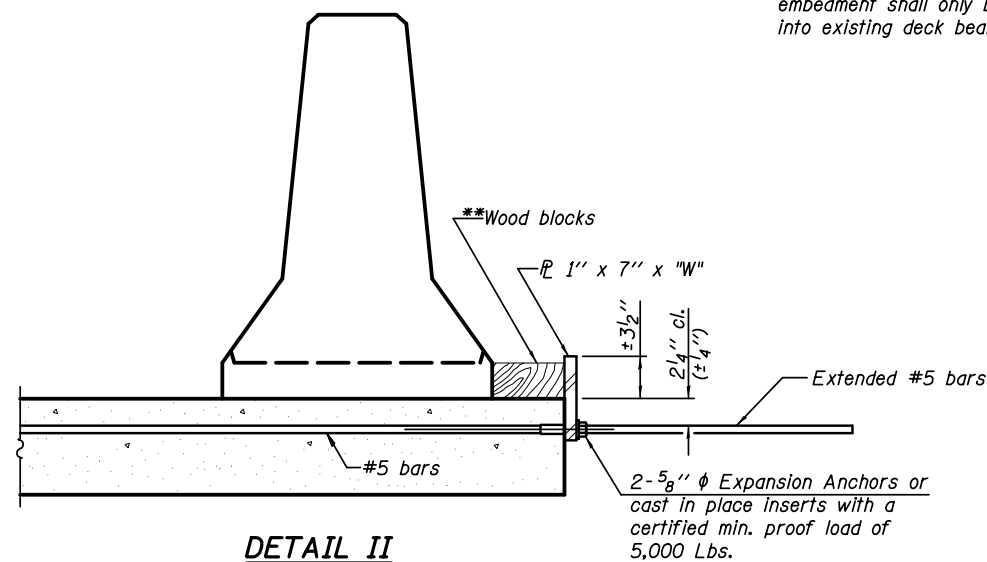

**DETAIL II**

\*\* Wood blocks may be omitted when required to provide minimum stage traffic lane width. When the wood blocks are omitted, the concrete barrier shall be in direct contact with the steel retainer plate.

"W" = Top bars spacing + 4"

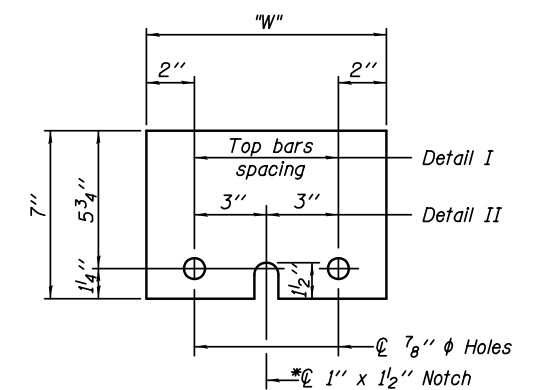

**STEEL RETAINER PL 1" x 7" x "W"**

\* Required only with Detail II

R-27

7-1-10

**KNIGHT**  
Engineers & Architects

DESIGNED - WPM	REVISION
CHECKED - TB	REVISION
DRAWN - TB	REVISION
CHECKED - WPM	REVISION
SCALE - NONE	
DATE - 10/15/2012	

**STATE OF ILLINOIS**  
**DEPARTMENT OF TRANSPORTATION**

**TEMPORARY CONCRETE BARRIER**  
S.N. 022-2029 (SB) TOLLWAY B.N. 826  
S.N. 022-2030 (NB) TOLLWAY B.N. 825

SHEET NO. SA-08 OF 63 SHEETS

F.A.P. RTE.	SECTION	COUNTY	TOTAL SHEETS	SHEET NO.
338	(112 & 113) WRS-5	DUPAGE	963	592
<b>CONTRACT NO. 60131</b>				

ILLINOIS FED. AID PROJECT

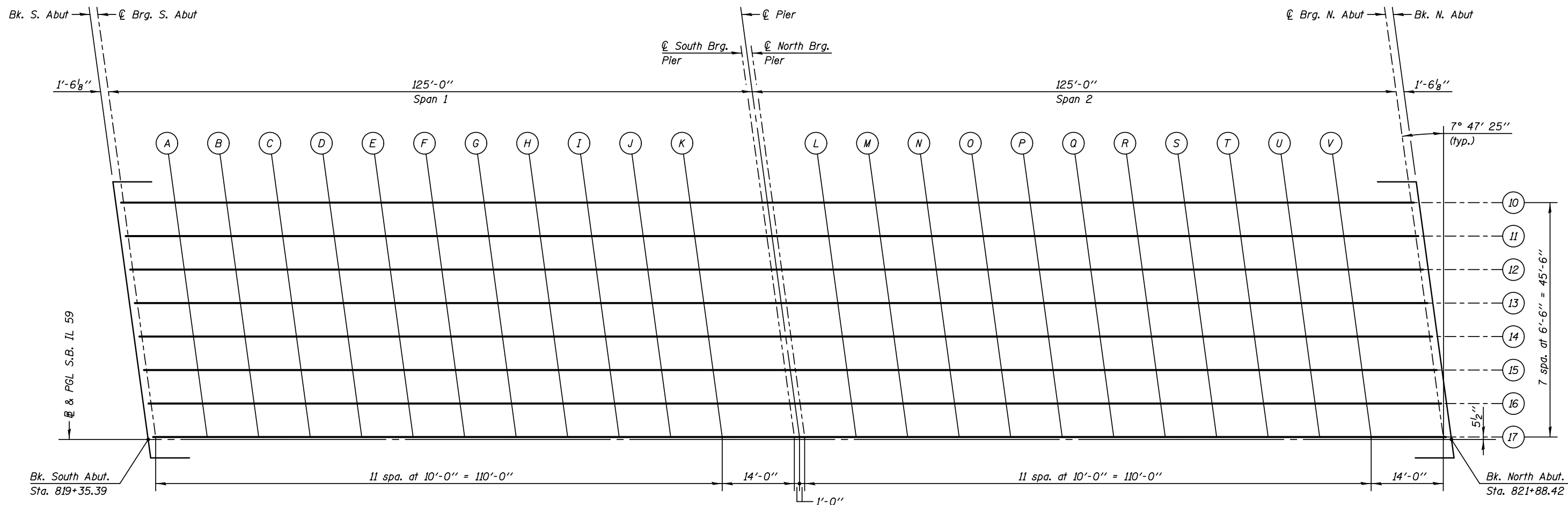
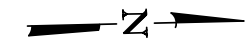

**PLAN**  
(SB Bridge)

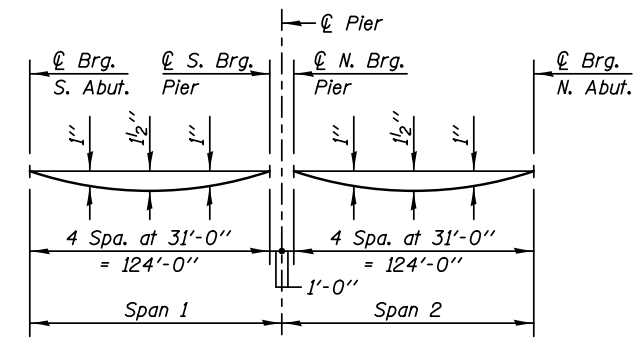

**DEAD LOAD DEFLECTION DIAGRAM**  
(Includes weight of concrete, excluding beams)

**Note:**  
The deflections shown are not to be used in the field if the Engineer is working from the grade elevations adjusted for dead load deflections as shown in TABLES.

**KNIGHT**  
Engineers & Architects

SCALE - NONE  
DATE - 10/15/2012

DESIGNED - WPM  
CHECKED - TB  
DRAWN - TB  
CHECKED - WPM

REVISED  
REVISED  
REVISED  
REVISED

**STATE OF ILLINOIS**  
**DEPARTMENT OF TRANSPORTATION**

**TOP OF SLAB ELEVATIONS (SB)**  
S.N. 022-2029 (SB) TOLLWAY B.N. 826  
S.N. 022-2030 (NB) TOLLWAY B.N. 825

F.A.P. RTE.	SECTION	COUNTY	TOTAL SHEETS	SHEET NO.
338	(112 & 113) WRS-5	DUPAGE	963	593
<b>CONTRACT NO. 60131</b>				

SHEET NO. SA-09 OF 63 SHEETS

ILLINOIS FED. AID PROJECT

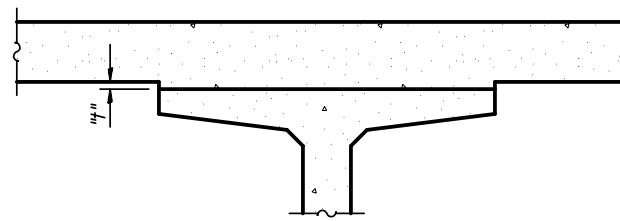

To determine "t": After all precast prestressed beams have been erected, elevations of the top flanges of the beams shall be taken at intervals shown on Sheet SA-09. These elevations subtracted from the "Theoretical Grade Elevations Adjusted for Dead Load Deflections" shown below, minus slab thickness, equals the fillet heights "t" above top flanges of beams.

**FILLET HEIGHTS**

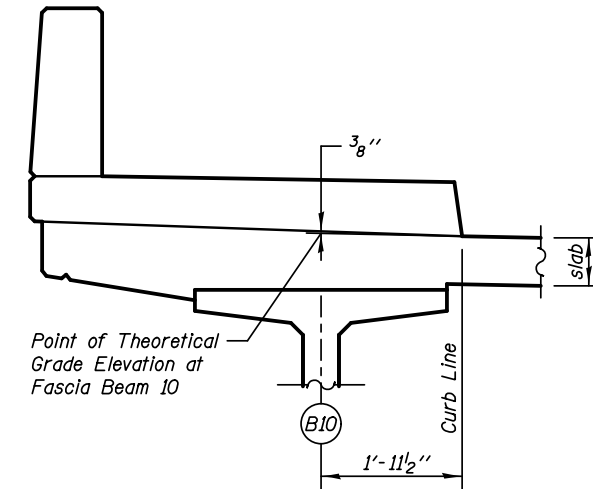

**SECTION THRU SIDEWALK**

**BEAM 10**

Location	Station	Offset	Theoretical Grade Elevations	Theoretical Grade Elevations Adjusted For Dead Load Deflection
Bk. S. Abut.	819+29.11	-45.96	731.26	731.26
@ Brg. S. Abut	819+30.62	-45.96	731.28	731.28
A	819+40.62	-45.96	731.38	731.41
B	819+50.62	-45.96	731.48	731.54
C	819+60.62	-45.96	731.57	731.65
D	819+70.62	-45.96	731.66	731.76
E	819+80.62	-45.96	731.74	731.86
F	819+90.62	-45.96	731.82	731.94
G	820+00.62	-45.96	731.89	732.01
H	820+10.62	-45.96	731.96	732.07
I	820+20.62	-45.96	732.02	732.11
J	820+30.62	-45.96	732.08	732.15
K	820+40.62	-45.96	732.13	732.17
S. Brg. Pier	820+54.62	-45.96	732.20	732.20
@ Pier	820+55.62	-45.96	732.20	732.20
N. Brg. Pier	820+56.62	-45.96	732.21	732.21
L	820+66.62	-45.96	732.25	732.27
M	820+76.62	-45.96	732.28	732.34
N	820+86.62	-45.96	732.31	732.39
O	820+96.62	-45.96	732.33	732.43
P	821+06.62	-45.96	732.35	732.47
Q	821+16.62	-45.96	732.37	732.49
R	821+26.62	-45.96	732.38	732.49
S	821+36.62	-45.96	732.38	732.49
T	821+46.62	-45.96	732.38	732.47
U	821+56.62	-45.96	732.37	732.44
V	821+66.62	-45.96	732.36	732.40
@ Brg. N. Abut	821+80.62	-45.96	732.34	732.34
Bk. N. Abut.	821+82.13	-45.96	732.33	732.33

**BEAM 11**

Location	Station	Offset	Theoretical Grade Elevations	Theoretical Grade Elevations Adjusted For Dead Load Deflection
Bk. S. Abut.	819+30.00	-39.46	731.13	731.13
@ Brg. S. Abut	819+31.51	-39.46	731.15	731.15
A	819+41.51	-39.46	731.25	731.28
B	819+51.51	-39.46	731.35	731.41
C	819+61.51	-39.46	731.44	731.53
D	819+71.51	-39.46	731.53	731.63
E	819+81.51	-39.46	731.61	731.73
F	819+91.51	-39.46	731.69	731.81
G	820+01.51	-39.46	731.76	731.88
H	820+11.51	-39.46	731.83	731.94
I	820+21.51	-39.46	731.89	731.98
J	820+31.51	-39.46	731.95	732.02
K	820+41.51	-39.46	732.00	732.04
S. Brg. Pier	820+55.51	-39.46	732.07	732.07
@ Pier	820+56.51	-39.46	732.07	732.07
N. Brg. Pier	820+57.51	-39.46	732.07	732.07
L	820+67.51	-39.46	732.11	732.14
M	820+77.51	-39.46	732.15	732.20
N	820+87.51	-39.46	732.18	732.26
O	820+97.51	-39.46	732.20	732.30
P	821+07.51	-39.46	732.22	732.33
Q	821+17.51	-39.46	732.23	732.35
R	821+27.51	-39.46	732.24	732.36
S	821+37.51	-39.46	732.24	732.35
T	821+47.51	-39.46	732.24	732.33
U	821+57.51	-39.46	732.24	732.31
V	821+67.51	-39.46	732.23	732.27
@ Brg. N. Abut	821+81.51	-39.46	732.20	732.20
Bk. N. Abut.	821+83.02	-39.46	732.20	732.20

**BEAM 12**

Location	Station	Offset	Theoretical Grade Elevations	Theoretical Grade Elevations Adjusted For Dead Load Deflection
Bk. S. Abut.	819+30.88	-32.96	731.01	731.01
@ Brg. S. Abut	819+32.40	-32.96	731.02	731.02
A	819+42.40	-32.96	731.13	731.16
B	819+52.40	-32.96	731.22	731.28
C	819+62.40	-32.96	731.32	731.40
D	819+72.40	-32.96	731.40	731.50
E	819+82.40	-32.96	731.49	731.60
F	819+92.40	-32.96	731.56	731.68
G	820+02.40	-32.96	731.63	731.75
H	820+12.40	-32.96	731.70	731.81
I	820+22.40	-32.96	731.76	731.85
J	820+32.40	-32.96	731.82	731.88
K	820+42.40	-32.96	731.87	731.91
S. Brg. Pier	820+56.40	-32.96	731.93	731.93
@ Pier	820+57.40	-32.96	731.94	731.94
N. Brg. Pier	820+58.40	-32.96	731.94	731.94
L	820+68.40	-32.96	731.98	732.01
M	820+78.40	-32.96	732.01	732.07
N	820+88.40	-32.96	732.04	732.12
O	820+98.40	-32.96	732.07	732.17
P	821+08.40	-32.96	732.09	732.20
Q	821+18.40	-32.96	732.10	732.22
R	821+28.40	-32.96	732.11	732.22
S	821+38.40	-32.96	732.11	732.22
T	821+48.40	-32.96	732.11	732.20
U	821+58.40	-32.96	732.10	732.17
V	821+68.40	-32.96	732.09	732.13
@ Brg. N. Abut	821+82.40	-32.96	732.06	732.06
Bk. N. Abut.	821+83.91	-32.96	732.06	732.06

**BEAM 13**

Location	Station	Offset	Theoretical Grade Elevations	Theoretical Grade Elevations Adjusted For Dead Load Deflection
Bk. S. Abut.	819+31.77	-26.46	730.88	730.88
⊕ Brg. S. Abut	819+33.29	-26.46	730.90	730.90
A	819+43.29	-26.46	731.00	731.03
B	819+53.29	-26.46	731.10	731.15
C	819+63.29	-26.46	731.19	731.27
D	819+73.29	-26.46	731.28	731.38
E	819+83.29	-26.46	731.36	731.47
F	819+93.29	-26.46	731.43	731.55
G	820+03.29	-26.46	731.50	731.62
H	820+13.29	-26.46	731.57	731.68
I	820+23.29	-26.46	731.63	731.72
J	820+33.29	-26.46	731.69	731.75
K	820+43.29	-26.46	731.74	731.78
S. Brg. Pier	820+57.29	-26.46	731.80	731.80
⊕ Pier	820+58.29	-26.46	731.81	731.81
N. Brg. Pier	820+59.29	-26.46	731.81	731.81
L	820+69.29	-26.46	731.85	731.88
M	820+79.29	-26.46	731.88	731.94
N	820+89.29	-26.46	731.91	731.99
O	820+99.29	-26.46	731.93	732.03
P	821+09.29	-26.46	731.95	732.06
Q	821+19.29	-26.46	731.96	732.08
R	821+29.29	-26.46	731.97	732.09
S	821+39.29	-26.46	731.97	732.08
T	821+49.29	-26.46	731.97	732.06
U	821+59.29	-26.46	731.96	732.03
V	821+69.29	-26.46	731.95	731.99
⊕ Brg. N. Abut	821+83.29	-26.46	731.93	731.93
Bk. N. Abut.	821+84.80	-26.46	731.92	731.92

**BEAM 14**

Location	Station	Offset	Theoretical Grade Elevations	Theoretical Grade Elevations Adjusted For Dead Load Deflection
Bk. S. Abut.	819+32.66	-19.96	730.76	730.76
⊕ Brg. S. Abut	819+34.18	-19.96	730.77	730.77
A	819+44.18	-19.96	730.87	730.90
B	819+54.18	-19.96	730.97	731.03
C	819+64.18	-19.96	731.06	731.14
D	819+74.18	-19.96	731.15	731.25
E	819+84.18	-19.96	731.23	731.34
F	819+94.18	-19.96	731.30	731.42
G	820+04.18	-19.96	731.38	731.49
H	820+14.18	-19.96	731.44	731.55
I	820+24.18	-19.96	731.50	731.59
J	820+34.18	-19.96	731.56	731.62
K	820+44.18	-19.96	731.61	731.65
S. Brg. Pier	820+58.18	-19.96	731.67	731.67
⊕ Pier	820+59.18	-19.96	731.68	731.68
N. Brg. Pier	820+60.18	-19.96	731.68	731.68
L	820+70.18	-19.96	731.72	731.74
M	820+80.18	-19.96	731.75	731.80
N	820+90.18	-19.96	731.78	731.86
O	821+00.18	-19.96	731.80	731.90
P	821+10.18	-19.96	731.82	731.93
Q	821+20.18	-19.96	731.83	731.95
R	821+30.18	-19.96	731.84	731.95
S	821+40.18	-19.96	731.84	731.95
T	821+50.18	-19.96	731.84	731.93
U	821+60.18	-19.96	731.83	731.90
V	821+70.18	-19.96	731.82	731.86
⊕ Brg. N. Abut	821+84.18	-19.96	731.79	731.79
Bk. N. Abut.	821+85.69	-19.96	731.79	731.79

**BEAM 15**

Location	Station	Offset	Theoretical Grade Elevations	Theoretical Grade Elevations Adjusted For Dead Load Deflection
Bk. S. Abut.	819+33.55	-13.46	730.63	730.63
⊕ Brg. S. Abut	819+35.07	-13.46	730.65	730.65
A	819+45.07	-13.46	730.75	730.78
B	819+55.07	-13.46	730.84	730.90
C	819+65.07	-13.46	730.93	731.02
D	819+75.07	-13.46	731.02	731.12
E	819+85.07	-13.46	731.10	731.21
F	819+95.07	-13.46	731.18	731.29
G	820+05.07	-13.46	731.25	731.36
H	820+15.07	-13.46	731.31	731.42
I	820+25.07	-13.46	731.37	731.46
J	820+35.07	-13.46	731.43	731.49
K	820+45.07	-13.46	731.48	731.52
S. Brg. Pier	820+59.07	-13.46	731.54	731.54
⊕ Pier	820+60.07	-13.46	731.54	731.54
N. Brg. Pier	820+61.07	-13.46	731.55	731.55
L	820+71.07	-13.46	731.58	731.61
M	820+81.07	-13.46	731.62	731.67
N	820+91.07	-13.46	731.64	731.72
O	821+01.07	-13.46	731.67	731.77
P	821+11.07	-13.46	731.68	731.80
Q	821+21.07	-13.46	731.69	731.81
R	821+31.07	-13.46	731.70	731.82
S	821+41.07	-13.46	731.70	731.81
T	821+51.07	-13.46	731.70	731.79
U	821+61.07	-13.46	731.69	731.76
V	821+71.07	-13.46	731.68	731.72
⊕ Brg. N. Abut	821+85.07	-13.46	731.65	731.65
Bk. N. Abut.	821+86.58	-13.46	731.65	731.65

**BEAM 16**

Location	Station	Offset	Theoretical Grade Elevations	Theoretical Grade Elevations Adjusted For Dead Load Deflection
Bk. S. Abut.	819+34.44	-6.96	730.50	730.50
⊘ Brg. S. Abut	819+35.96	-6.96	730.52	730.52
A	819+45.96	-6.96	730.62	730.65
B	819+55.96	-6.96	730.72	730.77
C	819+65.96	-6.96	730.81	730.89
D	819+75.96	-6.96	730.89	730.99
E	819+85.96	-6.96	730.97	731.09
F	819+95.96	-6.96	731.05	731.17
G	820+05.96	-6.96	731.12	731.23
H	820+15.96	-6.96	731.18	731.29
I	820+25.96	-6.96	731.24	731.33
J	820+35.96	-6.96	731.30	731.36
K	820+45.96	-6.96	731.35	731.39
S. Brg. Pier	820+59.96	-6.96	731.41	731.41
⊘ Pier	820+60.96	-6.96	731.41	731.41
N. Brg. Pier	820+61.96	-6.96	731.42	731.42
L	820+71.96	-6.96	731.45	731.48
M	820+81.96	-6.96	731.48	731.54
N	820+91.96	-6.96	731.51	731.59
O	821+01.96	-6.96	731.53	731.63
P	821+11.96	-6.96	731.55	731.66
Q	821+21.96	-6.96	731.56	731.68
R	821+31.96	-6.96	731.57	731.68
S	821+41.96	-6.96	731.57	731.68
T	821+51.96	-6.96	731.56	731.65
U	821+61.96	-6.96	731.56	731.62
V	821+71.96	-6.96	731.54	731.58
⊘ Brg. N. Abut	821+85.96	-6.96	731.51	731.51
Bk. N. Abut.	821+87.47	-6.96	731.51	731.51

**BEAM 17**

Location	Station	Offset	Theoretical Grade Elevations	Theoretical Grade Elevations Adjusted For Dead Load Deflection
Bk. S. Abut.	819+35.33	-0.46	730.38	730.38
⊘ Brg. S. Abut	819+36.84	-0.46	730.39	730.39
A	819+46.84	-0.46	730.49	730.52
B	819+56.84	-0.46	730.59	730.65
C	819+66.84	-0.46	730.68	730.76
D	819+76.84	-0.46	730.76	730.86
E	819+86.84	-0.46	730.84	730.96
F	819+96.84	-0.46	730.92	731.04
G	820+06.84	-0.46	730.99	731.10
H	820+16.84	-0.46	731.05	731.16
I	820+26.84	-0.46	731.11	731.20
J	820+36.84	-0.46	731.17	731.23
K	820+46.84	-0.46	731.22	731.25
S. Brg. Pier	820+60.84	-0.46	731.28	731.28
⊘ Pier	820+61.84	-0.46	731.28	731.28
N. Brg. Pier	820+62.84	-0.46	731.28	731.28
L	820+72.84	-0.46	731.32	731.35
M	820+82.84	-0.46	731.35	731.41
N	820+92.84	-0.46	731.38	731.46
O	821+02.84	-0.46	731.40	731.50
P	821+12.84	-0.46	731.41	731.53
Q	821+22.84	-0.46	731.43	731.54
R	821+32.84	-0.46	731.43	731.55
S	821+42.84	-0.46	731.43	731.54
T	821+52.84	-0.46	731.43	731.52
U	821+62.84	-0.46	731.42	731.49
V	821+72.84	-0.46	731.40	731.45
⊘ Brg. N. Abut	821+86.84	-0.46	731.38	731.38
Bk. N. Abut.	821+88.36	-0.46	731.37	731.37

**P.G. LINE & ⊘ SOUTHBOUND IL 59**

Location	Station	Offset	Theoretical Grade Elevations	Theoretical Grade Elevations Adjusted For Dead Load Deflection
Bk. S. Abut.	819+35.39	0.00	730.37	730.37
⊘ Brg. S. Abut	819+36.91	0.00	730.38	730.38
A	819+46.91	0.00	730.48	730.51
B	819+56.91	0.00	730.58	730.64
C	819+66.91	0.00	730.67	730.75
D	819+76.91	0.00	730.75	730.86
E	819+86.91	0.00	730.83	730.95
F	819+96.91	0.00	730.91	731.03
G	820+06.91	0.00	730.98	731.09
H	820+16.91	0.00	731.04	731.15
I	820+26.91	0.00	731.10	731.19
J	820+36.91	0.00	731.16	731.22
K	820+46.91	0.00	731.21	731.24
S. Brg. Pier	820+60.91	0.00	731.27	731.27
⊘ Pier	820+61.91	0.00	731.27	731.27
N. Brg. Pier	820+62.91	0.00	731.27	731.27
L	820+72.91	0.00	731.31	731.34
M	820+82.91	0.00	731.34	731.40
N	820+92.91	0.00	731.37	731.45
O	821+02.91	0.00	731.39	731.49
P	821+12.91	0.00	731.40	731.52
Q	821+22.91	0.00	731.42	731.53
R	821+32.91	0.00	731.42	731.54
S	821+42.91	0.00	731.42	731.53
T	821+52.91	0.00	731.42	731.51
U	821+62.91	0.00	731.41	731.48
V	821+72.91	0.00	731.39	731.44
⊘ Brg. N. Abut	821+86.91	0.00	731.37	731.37
Bk. N. Abut.	821+88.42	0.00	731.36	731.36



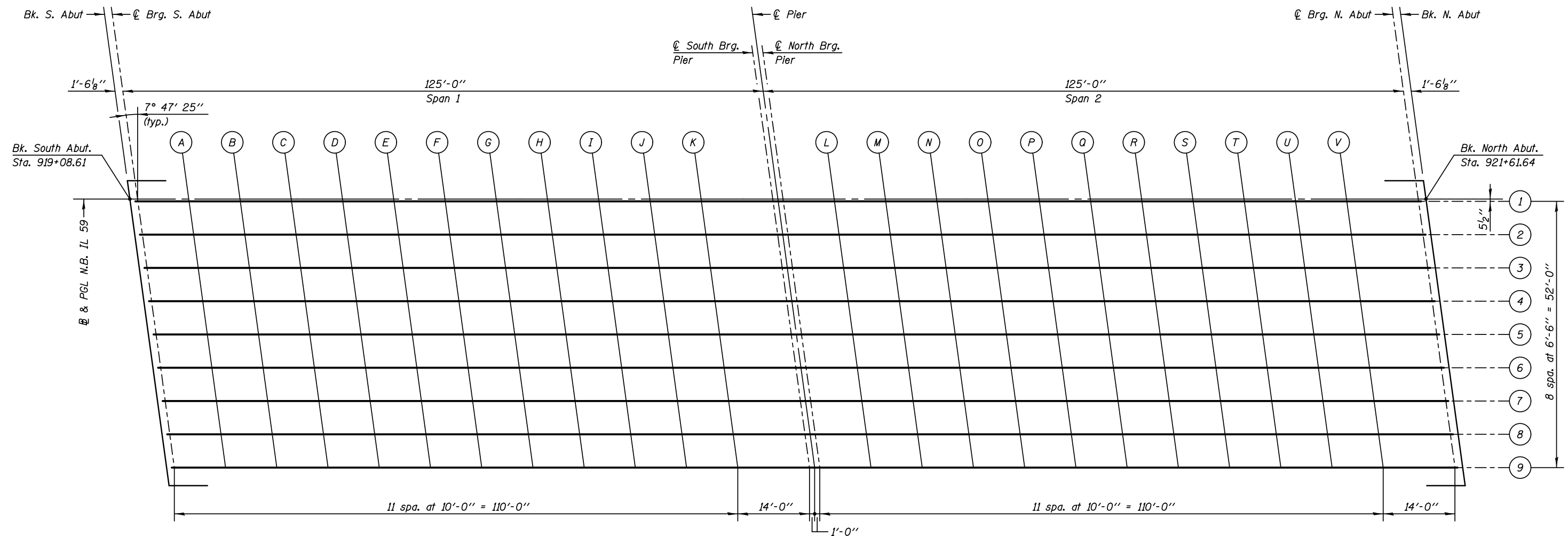
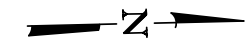

**PLAN**  
(NB Bridge)

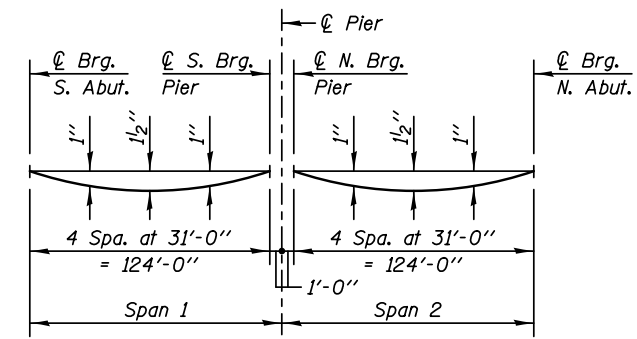

**DEAD LOAD DEFLECTION DIAGRAM**  
(Includes weight of concrete, excluding beams)

**Note:**  
The deflections shown are not to be used in the field if the Engineer is working from the grade elevations adjusted for dead load deflections as shown in TABLES.

**KNIGHT**  
Engineers & Architects

DESIGNED - WPM  
CHECKED - TB  
SCALE - NONE  
DATE - 10/15/2012

REVISOR  
REVISOR  
REVISOR  
REVISOR

**STATE OF ILLINOIS**  
**DEPARTMENT OF TRANSPORTATION**

**TOP OF SLAB ELEVATIONS (NB)**  
S.N. 022-2029 (SB) TOLLWAY B.N. 826  
S.N. 022-2030 (NB) TOLLWAY B.N. 825  
SHEET NO. SA-13 OF 63 SHEETS

F.A.P. RTE.	SECTION	COUNTY	TOTAL SHEETS	SHEET NO.
338	(112 & 113) WRS-5	DUPAGE	963	597
<b>CONTRACT NO. 60131</b>				
ILLINOIS FED. AID PROJECT				

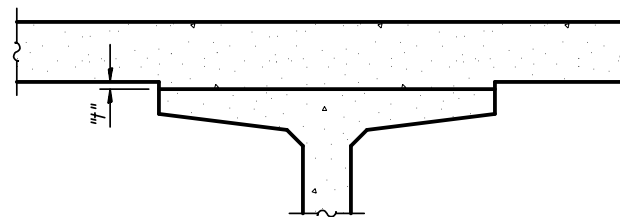

To determine "t": After all precast prestressed beams have been erected, elevations of the top flanges of the beams shall be taken at intervals shown on Sheet SA-13. These elevations subtracted from the "Theoretical Grade Elevations Adjusted for Dead Load Deflections" shown below, minus slab thickness, equals the fillet heights "t" above top flanges of beams.

**FILLET HEIGHTS**

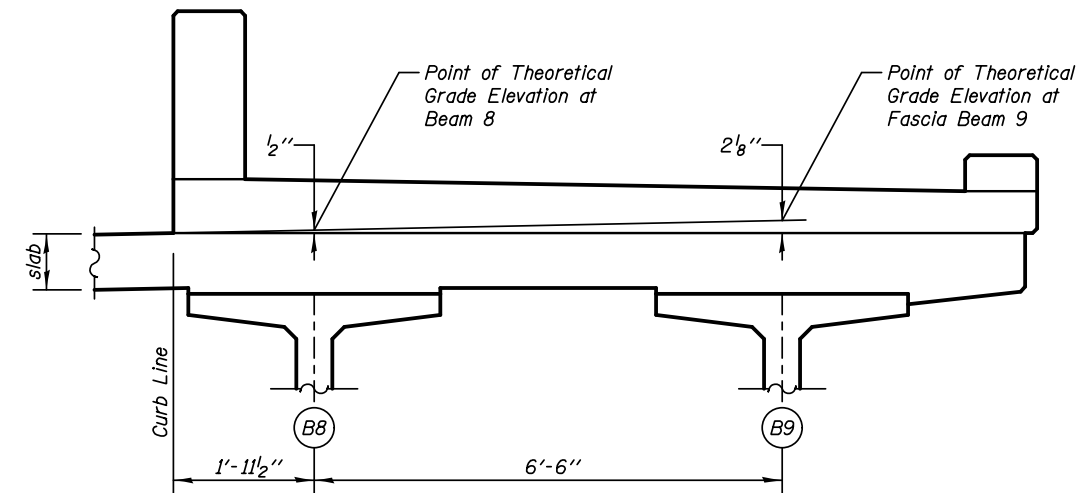

**SECTION THRU SIDEWALK**

**P.G. LINE & @ NORTHBOUND IL 59**

Location	Station	Offset	Theoretical Grade Elevations	Theoretical Grade Elevations Adjusted For Dead Load Deflection
Bk. S. Abut.	919+08.61	0.00	729.94	729.94
@ Brg. S. Abut	919+10.13	0.00	729.96	729.96
A	919+20.13	0.00	730.07	730.10
B	919+30.13	0.00	730.18	730.24
C	919+40.13	0.00	730.28	730.36
D	919+50.13	0.00	730.38	730.48
E	919+60.13	0.00	730.47	730.58
F	919+70.13	0.00	730.55	730.67
G	919+80.13	0.00	730.64	730.75
H	919+90.13	0.00	730.71	730.82
I	920+00.13	0.00	730.78	730.87
J	920+10.13	0.00	730.85	730.92
K	920+20.13	0.00	730.91	730.95
S. Brg. Pier	920+34.12	0.00	730.99	730.99
@ Pier	920+35.13	0.00	730.99	730.99
N. Brg. Pier	920+36.13	0.00	731.00	731.00
L	920+46.12	0.00	731.05	731.08
M	920+56.12	0.00	731.09	731.15
N	920+66.12	0.00	731.13	731.21
O	920+76.12	0.00	731.16	731.26
P	920+86.12	0.00	731.19	731.30
Q	920+96.12	0.00	731.21	731.33
R	921+06.12	0.00	731.23	731.35
S	921+16.12	0.00	731.24	731.35
T	921+26.12	0.00	731.25	731.34
U	921+36.12	0.00	731.25	731.32
V	921+46.12	0.00	731.25	731.29
@ Brg. N. Abut	921+60.13	0.00	731.24	731.24
Bk. N. Abut.	921+61.64	0.00	731.24	731.24

**BEAM 1**

Location	Station	Offset	Theoretical Grade Elevations	Theoretical Grade Elevations Adjusted For Dead Load Deflection
Bk. S. Abut.	919+08.67	0.46	729.95	729.95
@ Brg. S. Abut	919+10.19	0.46	729.97	729.97
A	919+20.19	0.46	730.08	730.11
B	919+30.19	0.46	730.19	730.25
C	919+40.19	0.46	730.29	730.37
D	919+50.19	0.46	730.39	730.49
E	919+60.19	0.46	730.48	730.59
F	919+70.19	0.46	730.56	730.68
G	919+80.19	0.46	730.65	730.76
H	919+90.19	0.46	730.72	730.83
I	920+00.19	0.46	730.79	730.88
J	920+10.19	0.46	730.86	730.93
K	920+20.19	0.46	730.92	730.96
S. Brg. Pier	920+34.19	0.46	731.00	731.00
@ Pier	920+35.19	0.46	731.00	731.00
N. Brg. Pier	920+36.19	0.46	731.01	731.01
L	920+46.19	0.46	731.06	731.09
M	920+56.19	0.46	731.10	731.16
N	920+66.19	0.46	731.14	731.22
O	920+76.19	0.46	731.17	731.27
P	920+86.19	0.46	731.20	731.31
Q	920+96.19	0.46	731.22	731.34
R	921+06.19	0.46	731.24	731.36
S	921+16.19	0.46	731.25	731.36
T	921+26.19	0.46	731.26	731.35
U	921+36.19	0.46	731.26	731.33
V	921+46.19	0.46	731.26	731.30
@ Brg. N. Abut	921+60.19	0.46	731.25	731.25
Bk. N. Abut.	921+61.70	0.46	731.25	731.25

**BEAM 2**

Location	Station	Offset	Theoretical Grade Elevations	Theoretical Grade Elevations Adjusted For Dead Load Deflection
Bk. S. Abut.	919+09.56	6.96	730.10	730.10
@ Brg. S. Abut	919+11.08	6.96	730.11	730.11
A	919+21.08	6.96	730.22	730.25
B	919+31.08	6.96	730.33	730.39
C	919+41.08	6.96	730.43	730.52
D	919+51.08	6.96	730.53	730.63
E	919+61.08	6.96	730.62	730.74
F	919+71.08	6.96	730.71	730.83
G	919+81.08	6.96	730.79	730.91
H	919+91.08	6.96	730.86	730.97
I	920+01.08	6.96	730.93	731.02
J	920+11.08	6.96	731.00	731.07
K	920+21.08	6.96	731.06	731.10
S. Brg. Pier	920+35.08	6.96	731.14	731.14
@ Pier	920+36.08	6.96	731.14	731.14
N. Brg. Pier	920+37.08	6.96	731.15	731.15
L	920+47.08	6.96	731.20	731.22
M	920+57.08	6.96	731.24	731.30
N	920+67.08	6.96	731.28	731.36
O	920+77.08	6.96	731.31	731.41
P	920+87.08	6.96	731.34	731.45
Q	920+97.08	6.96	731.36	731.48
R	921+07.08	6.96	731.38	731.50
S	921+17.08	6.96	731.39	731.50
T	921+27.08	6.96	731.40	731.49
U	921+37.08	6.96	731.40	731.47
V	921+47.08	6.96	731.40	731.44
@ Brg. N. Abut	921+61.08	6.96	731.38	731.38
Bk. N. Abut.	921+62.59	6.96	731.38	731.38

**BEAM 3**

Location	Station	Offset	Theoretical Grade Elevations	Theoretical Grade Elevations Adjusted For Dead Load Deflection
Bk. S. Abut.	919+10.45	13.46	730.24	730.24
⊕ Brg. S. Abut	919+11.97	13.46	730.26	730.26
A	919+21.97	13.46	730.37	730.40
B	919+31.97	13.46	730.48	730.53
C	919+41.97	13.46	730.58	730.66
D	919+51.97	13.46	730.67	730.78
E	919+61.97	13.46	730.76	730.88
F	919+71.97	13.46	730.85	730.97
G	919+81.97	13.46	730.93	731.05
H	919+91.97	13.46	731.01	731.11
I	920+01.97	13.46	731.08	731.17
J	920+11.97	13.46	731.14	731.21
K	920+21.97	13.46	731.20	731.24
S. Brg. Pier	920+35.97	13.46	731.28	731.28
⊕ Pier	920+36.97	13.46	731.28	731.28
N. Brg. Pier	920+37.97	13.46	731.29	731.29
L	920+47.97	13.46	731.34	731.36
M	920+57.97	13.46	731.38	731.43
N	920+67.97	13.46	731.42	731.50
O	920+77.97	13.46	731.45	731.55
P	920+87.97	13.46	731.48	731.59
Q	920+97.97	13.46	731.50	731.62
R	921+07.97	13.46	731.51	731.63
S	921+17.97	13.46	731.53	731.64
T	921+27.97	13.46	731.53	731.63
U	921+37.97	13.46	731.54	731.60
V	921+47.97	13.46	731.53	731.57
⊕ Brg. N. Abut	921+61.97	13.46	731.52	731.52
Bk. N. Abut.	921+63.48	13.46	731.52	731.52

**BEAM 4**

Location	Station	Offset	Theoretical Grade Elevations	Theoretical Grade Elevations Adjusted For Dead Load Deflection
Bk. S. Abut.	919+11.34	19.96	730.39	730.39
⊕ Brg. S. Abut	919+12.86	19.96	730.40	730.40
A	919+22.86	19.96	730.51	730.55
B	919+32.86	19.96	730.62	730.68
C	919+42.86	19.96	730.72	730.80
D	919+52.86	19.96	730.82	730.92
E	919+62.86	19.96	730.91	731.02
F	919+72.86	19.96	730.99	731.11
G	919+82.86	19.96	731.07	731.19
H	919+92.86	19.96	731.15	731.25
I	920+02.86	19.96	731.22	731.31
J	920+12.86	19.96	731.28	731.35
K	920+22.86	19.96	731.34	731.38
S. Brg. Pier	920+36.86	19.96	731.42	731.42
⊕ Pier	920+37.86	19.96	731.42	731.42
N. Brg. Pier	920+38.86	19.96	731.43	731.43
L	920+48.86	19.96	731.48	731.50
M	920+58.86	19.96	731.52	731.57
N	920+68.86	19.96	731.55	731.63
O	920+78.86	19.96	731.59	731.69
P	920+88.86	19.96	731.61	731.73
Q	920+98.86	19.96	731.63	731.75
R	921+08.86	19.96	731.65	731.77
S	921+18.86	19.96	731.66	731.77
T	921+28.86	19.96	731.67	731.76
U	921+38.86	19.96	731.67	731.74
V	921+48.86	19.96	731.67	731.71
⊕ Brg. N. Abut	921+62.86	19.96	731.65	731.65
Bk. N. Abut.	921+64.37	19.96	731.65	731.65

**BEAM 5**

Location	Station	Offset	Theoretical Grade Elevations	Theoretical Grade Elevations Adjusted For Dead Load Deflection
Bk. S. Abut.	919+12.23	26.46	730.53	730.53
⊕ Brg. S. Abut	919+13.74	26.46	730.55	730.55
A	919+23.74	26.46	730.66	730.69
B	919+33.74	26.46	730.77	730.82
C	919+43.74	26.46	730.87	730.95
D	919+53.74	26.46	730.96	731.06
E	919+63.74	26.46	731.05	731.17
F	919+73.74	26.46	731.14	731.26
G	919+83.74	26.46	731.21	731.33
H	919+93.74	26.46	731.29	731.40
I	920+03.74	26.46	731.36	731.45
J	920+13.74	26.46	731.42	731.49
K	920+23.74	26.46	731.48	731.52
S. Brg. Pier	920+37.74	26.46	731.56	731.56
⊕ Pier	920+38.74	26.46	731.56	731.56
N. Brg. Pier	920+39.74	26.46	731.57	731.57
L	920+49.74	26.46	731.61	731.64
M	920+59.74	26.46	731.66	731.71
N	920+69.74	26.46	731.69	731.77
O	920+79.74	26.46	731.72	731.82
P	920+89.74	26.46	731.75	731.86
Q	920+99.74	26.46	731.77	731.89
R	921+09.74	26.46	731.79	731.91
S	921+19.74	26.46	731.80	731.91
T	921+29.74	26.46	731.80	731.90
U	921+39.74	26.46	731.81	731.88
V	921+49.74	26.46	731.80	731.84
⊕ Brg. N. Abut	921+63.74	26.46	731.79	731.79
Bk. N. Abut.	921+65.26	26.46	731.79	731.79

**BEAM 6**

Location	Station	Offset	Theoretical Grade Elevations	Theoretical Grade Elevations Adjusted For Dead Load Deflection
Bk. S. Abut.	919+13.12	32.96	730.68	730.68
⊕ Brg. S. Abut	919+14.63	32.96	730.70	730.70
A	919+24.63	32.96	730.80	730.84
B	919+34.63	32.96	730.91	730.97
C	919+44.63	32.96	731.01	731.09
D	919+54.63	32.96	731.10	731.21
E	919+64.63	32.96	731.19	731.31
F	919+74.63	32.96	731.28	731.40
G	919+84.63	32.96	731.36	731.47
H	919+94.63	32.96	731.43	731.54
I	920+04.63	32.96	731.50	731.59
J	920+14.63	32.96	731.56	731.63
K	920+24.63	32.96	731.62	731.66
S. Brg. Pier	920+38.63	32.96	731.70	731.70
⊕ Pier	920+39.63	32.96	731.70	731.70
N. Brg. Pier	920+40.63	32.96	731.71	731.71
L	920+50.63	32.96	731.75	731.78
M	920+60.63	32.96	731.80	731.85
N	920+70.63	32.96	731.83	731.91
O	920+80.63	32.96	731.86	731.96
P	920+90.63	32.96	731.89	732.00
Q	921+00.63	32.96	731.91	732.03
R	921+10.63	32.96	731.92	732.04
S	921+20.63	32.96	731.93	732.04
T	921+30.63	32.96	731.94	732.03
U	921+40.63	32.96	731.94	732.01
V	921+50.63	32.96	731.94	731.98
⊕ Brg. N. Abut	921+64.63	32.96	731.92	731.92
Bk. N. Abut.	921+66.15	32.96	731.92	731.92

**BEAM 7**

Location	Station	Offset	Theoretical Grade Elevations	Theoretical Grade Elevations Adjusted For Dead Load Deflection
Bk. S. Abut.	919+14.01	39.46	730.82	730.82
⊕ Brg. S. Abut	919+15.52	39.46	730.84	730.84
A	919+25.52	39.46	730.95	730.98
B	919+35.52	39.46	731.05	731.11
C	919+45.52	39.46	731.15	731.24
D	919+55.52	39.46	731.25	731.35
E	919+65.52	39.46	731.34	731.45
F	919+75.52	39.46	731.42	731.54
G	919+85.52	39.46	731.50	731.62
H	919+95.52	39.46	731.57	731.68
I	920+05.52	39.46	731.64	731.73
J	920+15.52	39.46	731.71	731.77
K	920+25.52	39.46	731.76	731.80
S. Brg. Pier	920+39.52	39.46	731.84	731.84
⊕ Pier	920+40.52	39.46	731.84	731.84
N. Brg. Pier	920+41.52	39.46	731.85	731.85
L	920+51.52	39.46	731.89	731.92
M	920+61.52	39.46	731.93	731.99
N	920+71.52	39.46	731.97	732.05
O	920+81.52	39.46	732.00	732.10
P	920+91.52	39.46	732.03	732.14
Q	921+01.52	39.46	732.05	732.17
R	921+11.52	39.46	732.06	732.18
S	921+21.52	39.46	732.07	732.18
T	921+31.52	39.46	732.08	732.17
U	921+41.52	39.46	732.08	732.15
V	921+51.52	39.46	732.07	732.11
⊕ Brg. N. Abut	921+65.52	39.46	732.06	732.06
Bk. N. Abut.	921+67.04	39.46	732.05	732.05

**BEAM 8**

Location	Station	Offset	Theoretical Grade Elevations	Theoretical Grade Elevations Adjusted For Dead Load Deflection
Bk. S. Abut.	919+14.90	45.96	730.97	730.97
⊕ Brg. S. Abut	919+16.41	45.96	730.99	730.99
A	919+26.41	45.96	731.09	731.12
B	919+36.41	45.96	731.20	731.26
C	919+46.41	45.96	731.30	731.38
D	919+56.41	45.96	731.39	731.49
E	919+66.41	45.96	731.48	731.60
F	919+76.41	45.96	731.56	731.68
G	919+86.41	45.96	731.64	731.76
H	919+96.41	45.96	731.71	731.82
I	920+06.41	45.96	731.78	731.87
J	920+16.41	45.96	731.85	731.91
K	920+26.41	45.96	731.90	731.94
S. Brg. Pier	920+40.41	45.96	731.98	731.98
⊕ Pier	920+41.41	45.96	731.98	731.98
N. Brg. Pier	920+42.41	45.96	731.99	731.99
L	920+52.41	45.96	732.03	732.06
M	920+62.41	45.96	732.07	732.13
N	920+72.41	45.96	732.11	732.19
O	920+82.41	45.96	732.14	732.24
P	920+92.41	45.96	732.16	732.28
Q	921+02.41	45.96	732.18	732.30
R	921+12.41	45.96	732.20	732.32
S	921+22.41	45.96	732.21	732.32
T	921+32.41	45.96	732.21	732.30
U	921+42.41	45.96	732.21	732.28
V	921+52.41	45.96	732.21	732.25
⊕ Brg. N. Abut	921+66.41	45.96	732.19	732.19
Bk. N. Abut.	921+67.93	45.96	732.19	732.19