

ELEVATION

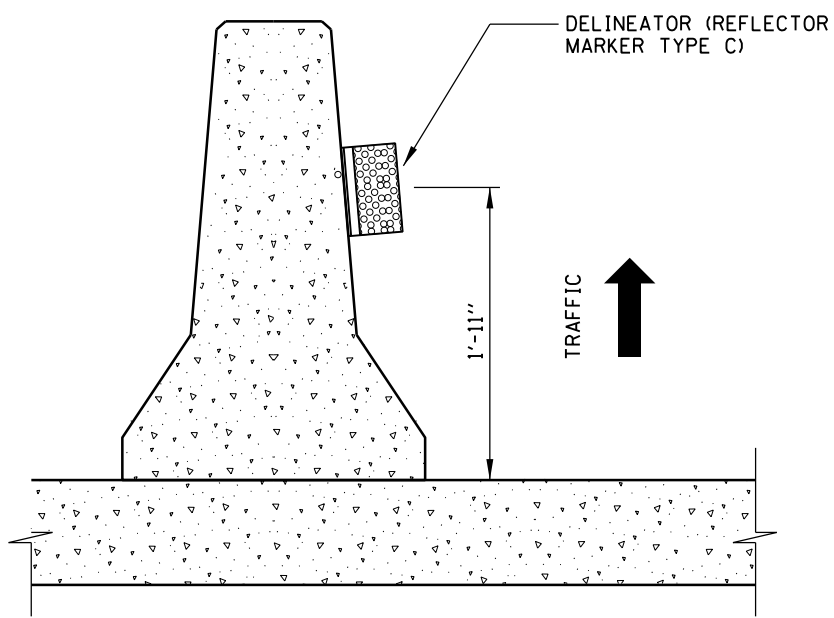

CROSS-SECTION

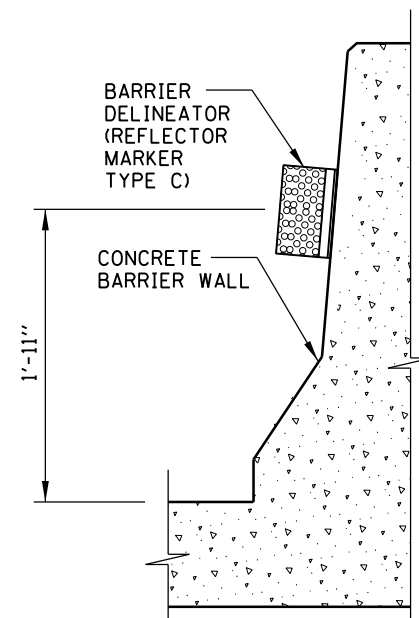

BARRIER OR PARAPET
DELINEATOR INSTALLATION

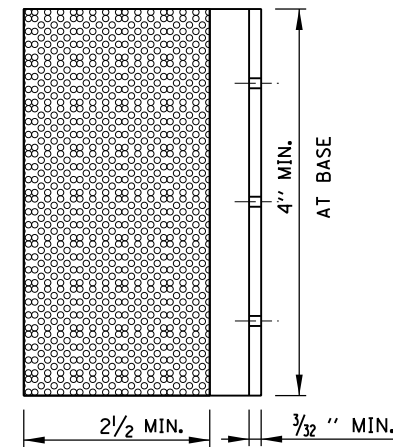

DELINEATOR
(REFLECTOR MARKER TYPE C)

TEMPORARY CONCRETE BARRIER

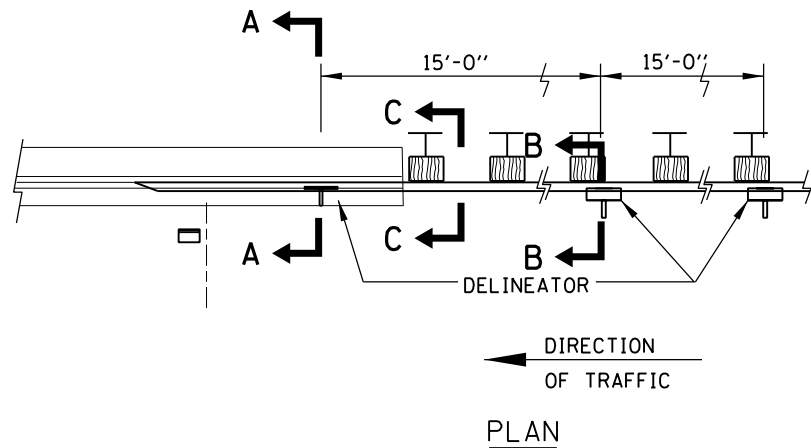

PLAN

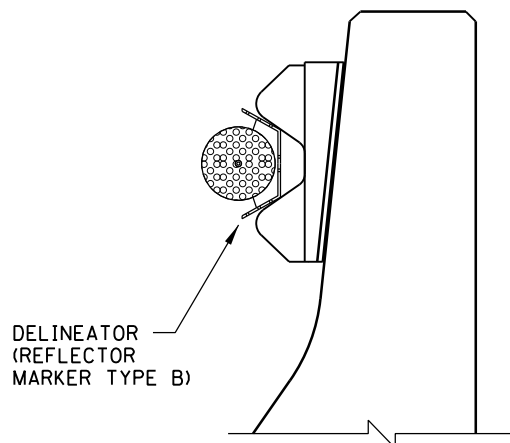

SECTION A-A

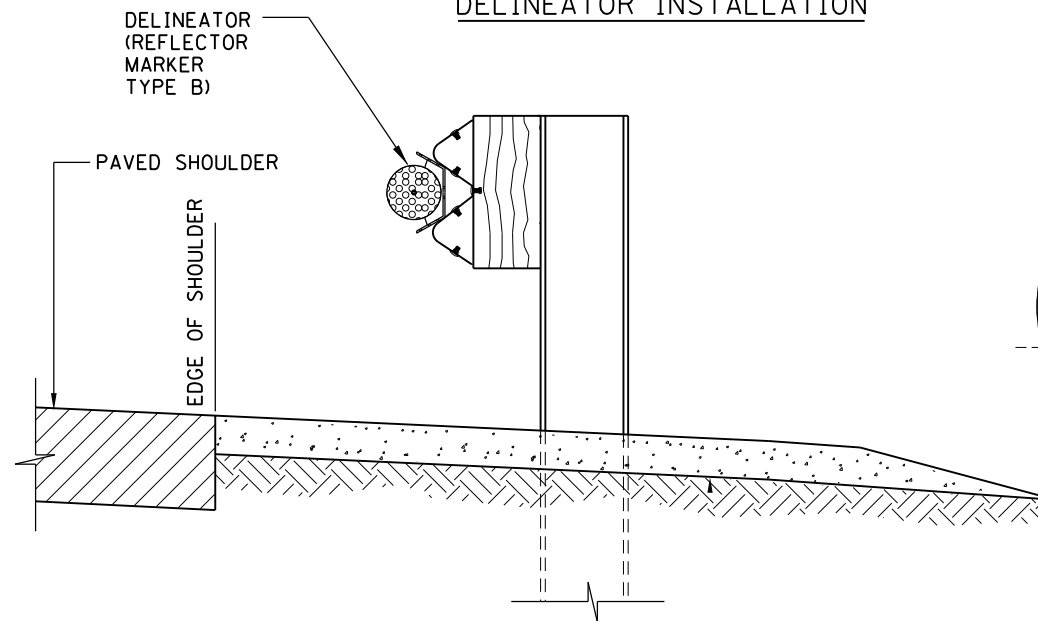

SECTION B-B

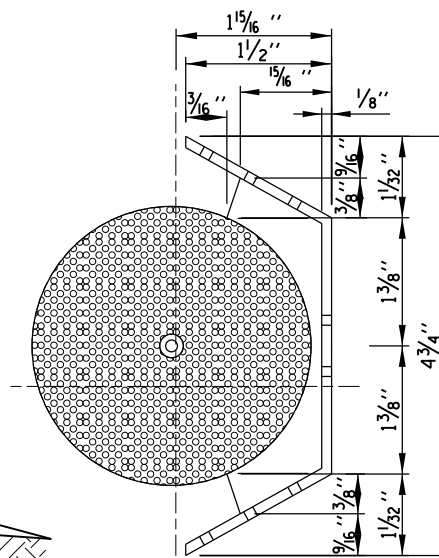

DELINEATOR
(REFLECTOR MARKER TYPE B)

DELINEATOR INSTALLATION ON GUARDRAIL
AT BRIDGE APPROACHES

ALSO SEE SHEET 1 (OF 3) IN THIS SERIES FOR ADDITIONAL INFORMATION

NOTES FOR BARRIER DELINEATOR:

1. THE DELINEATORS SHALL BE PLACED AT 100 FOOT SPACINGS ALONG ROADWAY AND 50 FOOT ON BRIDGES AND THREE DELINEATORS AT 15 FOOT SPACINGS ON BRIDGE APPROACHES. THE SPACINGS ARE THE SAME FOR TANGENT AND CURVE ALIGNMENTS. WHITE DELINEATOR SHALL BE PLACED ON THE RIGHT SIDE AND AMBER ON THE LEFT SIDE.
2. REFLECTOR MARKERS TYPE B AND TYPE C SHALL HAVE REFLECTIVE SURFACE ON ONE SIDE ONLY.

NOTE:

SEE SHEET 1 OF THIS SERIES FOR NOTES.
CONTRACT 60I31 SHEET 928 OF 963
SHEET 3 OF 3

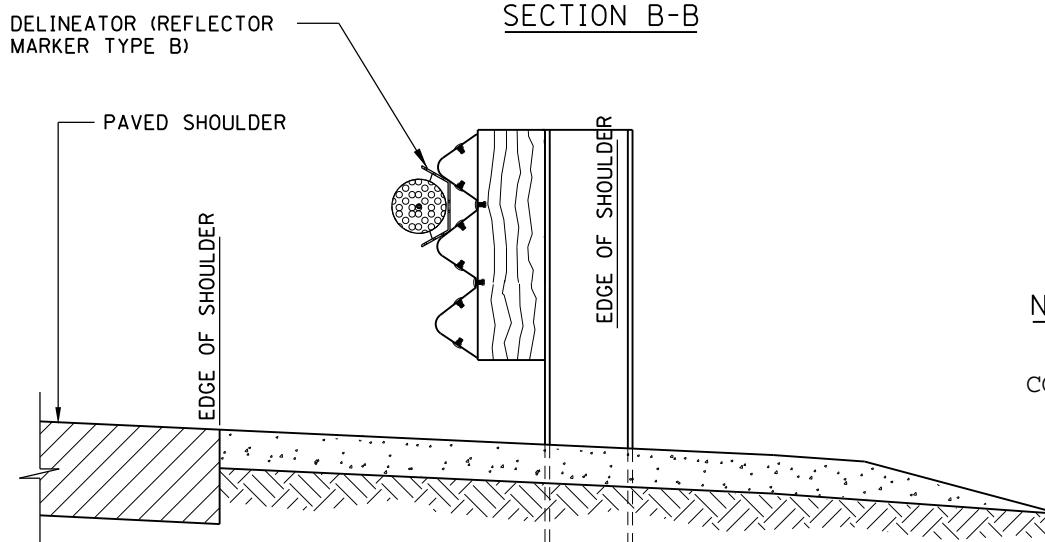

SECTION C-C

APPROVED *Paul Kovacs* CHIEF ENGINEER DATE 7-1-2009



DELINEATORS

STANDARD D4-02