

DIMENSIONS AND QUANTITIES FOR ONE SLOPED HEADWALL TYPE III

PIPE I.D.	DIMENSIONS											PRE CAST CONC. CU. YD.	CAST-IN-PLACE CU. YD.	WELDED WIRE FABRIC SQ. YD.	REINF. STEEL				
	A	B	C	N	M	P	S	L	V	W	MARK				SIZE	NO.	LENGTH	LBS.	
6"	9"	2 3/4"	1'-9 3/4"	1'-0"	1'-8"	1'-6 3/4"	2'-11 1/4"	7'-2"	1'-0"	3'-6"	.19	.51	2.67	d6	#4	12	2'-0"	16	
12"	1'-3 1/2"	2 3/4"	2'-4 1/4"	1'-0"	1'-8"	1'-6 3/4"	4'-6 3/4"	8'-9 1/2"	1'-0"	4'-0"	.36	.65	3.80	d12	#4	14	2'-0"	19	
15"	1'-6 1/2"	2 3/4"	2'-7 1/4"	1'-0"	1'-8"	1'-6 3/4"	5'-3 3/4"	9'-6 1/2"	1'-0"	4'-3"	.47	.73	5.13	d15	#4	16	2'-0"	21	
18"	1'-10"	2 3/4"	2'-10 3/4"	1'-0"	1'-8"	1'-6 3/4"	6'-2 1/4"	10'-5"	1'-0"	4'-6"	.61	.80	5.65	d18	#4	18	2'-0"	24	
21"	2'-1"	2 3/4"	3'-1 3/4"	1'-0"	1'-9"	1'-6 3/4"	6'-11 1/4"	11'-3"	1'-3"	5'-3"	.74	1.0	7.42	d21	#4	22	2'-0"	29	
24"	2'-4 1/2"	2 3/4"	3'-5 1/4"	1'-0"	2'-0"	1'-6 3/4"	7'-9 3/4"	12'-4 1/2"	1'-6"	6'-0"	.86	1.24	8.80	d24	#4	24	2'-0"	32	
27"	2'-7 1/2"	2 3/4"	3'-8 1/4"	1'-1 1/2"	2'-3"	1'-6 3/4"	8'-6 3/4"	13'-6"	1'-9"	6'-9"	1.03	1.53	12.35	d27	#4	24	2'-0"	32	
30"	2'-11"	2 3/4"	3'-11 3/4"	1'-3"	2'-6"	1'-6 3/4"	9'-5 1/4"	14'-9"	2'-0"	7'-6"	1.22	2.00	15.08	d30	#4	26	2'-0"	35	

PIPE I.D.	DIMENSIONS											PRE CAST CONC. CU. YD.	CAST-IN-PLACE CU. YD.	WELDED WIRE FABRIC SQ. YD.	REINF. STEEL				
	A	B	C	N	M	P	S	L	V	W	MARK				SIZE	NO.	LENGTH	LBS.	
6"	9"	2"	1'-9"	1'-0"	1'-8"	2'-1"	3'-8"	8'-5"	1'-0"	3'-6"	.21	.57	3.27	d6	#4	12	2'-0"	16	
12"	1'-3 1/2"	2"	2'-3 1/2"	1'-0"	1'-8"	2'-1"	5'-10"	10'-7"	1'-0"	4'-0"	.44	.75	4.58	d12	#4	16	2'-0"	21	
15"	1'-6 1/2"	2"	2'-6 1/2"	1'-0"	1'-8"	2'-1"	6'-10"	11'-7"	1'-0"	4'-3"	.57	.83	5.66	d15	#4	18	2'-0"	24	
18"	1'-10"	2"	2'-10"	1'-0"	1'-8"	2'-1"	8'-0"	12'-11"	1'-0"	4'-6"	.73	.93	7.57	d18	#4	22	2'-0"	29	
21"	2'-1"	2"	3'-1"	1'-0"	1'-9"	2'-1"	9'-0"	13'-10"	1'-3"	5'-3"	.89	1.16	9.83	d21	#4	24	2'-0"	32	
24"	2'-4 1/2"	2"	3'-4 1/2"	1'-0"	2'-0"	2'-1"	10'-2"	15'-3"	1'-6"	6'-0"	1.12	1.45	12.51	d24	#4	28	2'-0"	37	
27"	2'-7 1/2"	2"	3'-7 1/2"	1'-1 1/2"	2'-3"	2'-1"	11'-2"	16'-7"	1'-9"	6'-9"	1.32	1.77	13.28	d27	#4	30	2'-0"	40	
30"	2'-11"	2"	3'-11"	1'-3"	2'-6"	2'-1"	12'-4"	18'-2"	2'-0"	7'-6"	1.58	2.14	18.77	d30	#4	32	2'-0"	43	

PIPE I.D.	DIMENSIONS											PRE CAST CONC. CU. YD.	CAST-IN-PLACE CU. YD.	WELDED WIRE FABRIC SQ. YD.	REINF. STEEL				
	A	B	C	N	M	P	S	L	V	W	MARK				SIZE	NO.	LENGTH	LBS.	
6"	9"	1 1/2"	1'-8 1/2"	1'-0"	1'-8"	3'-0"	5'-3"	10'-11"	1'-0"	3'-6"	.29	.71	4.11	d6	#4	16	2'-0"	21	
12"	1'-3 1/2"	1 1/2"	2'-3"	1'-0"	1'-8"	3'-0"	8'-6"	14'-2"	1'-0"	4'-0"	.60	.96	7.27	d12	#4	22	2'-0"	29	
15"	1'-6 1/2"	1 1/2"	2'-6"	1'-0"	1'-8"	3'-0"	10'-0"	15'-8"	1'-0"	4'-3"	.79	1.07	8.91	d15	#4	26	2'-0"	35	
18"	1'-10"	1 1/2"	2'-9 1/2"	1'-0"	1'-8"	3'-0"	11'-9"	17'-5"	1'-0"	4'-6"	1.03	1.20	10.95	d18	#4	28	2'-0"	37	
21"	2'-1"	1 1/2"	3'-0 1/2"	1'-0"	1'-9"	3'-0"	13'-3"	19'-0"	1'-3"	5'-3"	1.29	1.51	14.00	d21	#4	34	2'-0"	45	
24"	2'-4 1/2"	1 1/2"	3'-4"	1'-0"	2'-0"	3'-0"	15'-0"	21'-0"	1'-6"	6'-0"	1.59	1.89	15.49	d24	#4	38	2'-0"	51	
27"	2'-7 1/2"	1 1/2"	3'-7"	1'-1 1/2"	2'-3"	3'-0"	16'-6"	22'-10 1/2"	1'-9"	6'-9"	1.90	2.30	21.82	d27	#4	40	2'-0"	53	
30"	2'-11"	1 1/2"	3'-10 1/2"	1'-3"	2'-6"	3'-0"	18'-3"	25'-0"	2'-0"	7'-6"	2.27	2.79	26.60	d30	#4	44	2'-0"	59	

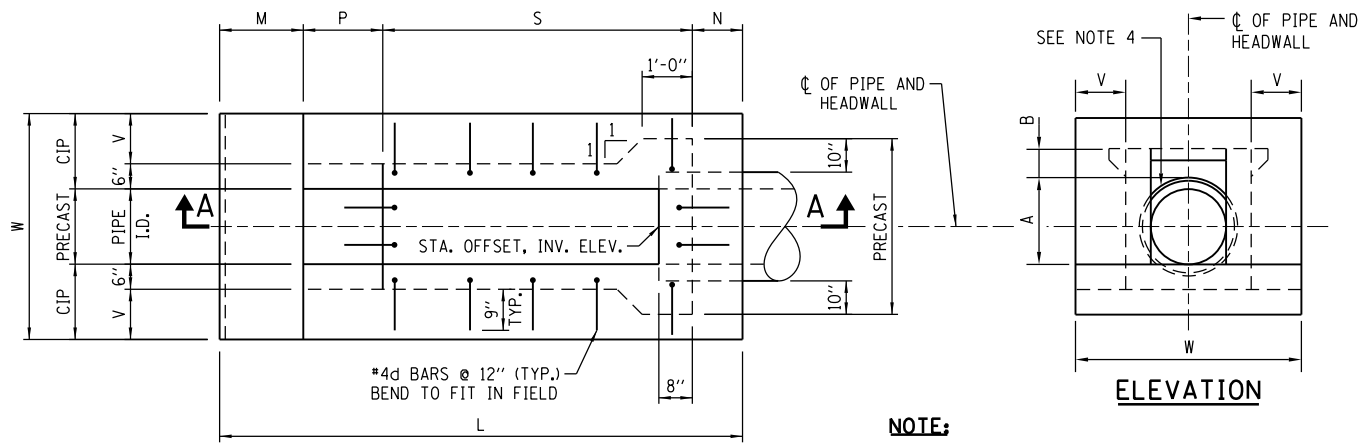

NOTE:
EACH #4d BAR SHALL BE PLACED SUCH THAT IT WILL PROJECT 9" INTO THE CAST IN PLACE (CIP) CONCRETE AND IT SHALL BE 3" BELOW THE TOP SURFACE. HOOKS IN THE PRECAST SECTION SHALL BE TIPPED TO CLEAR ALL CONCRETE SURFACES A MIN. OF 2".

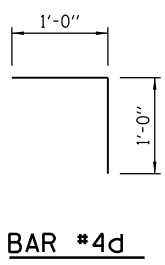
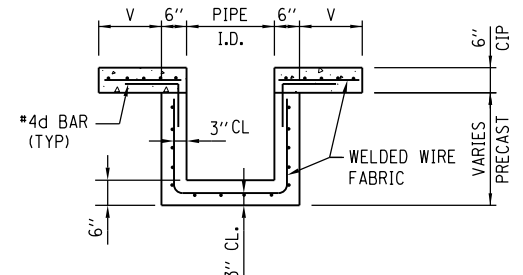
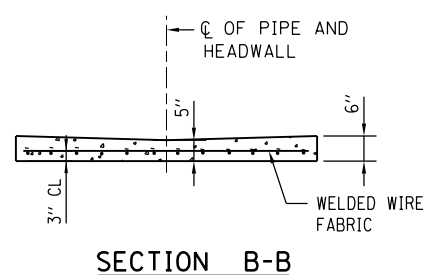
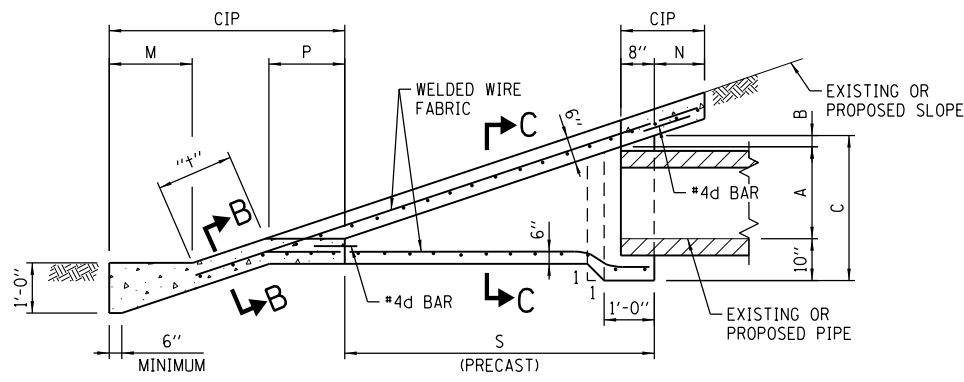
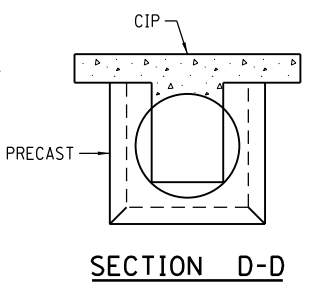
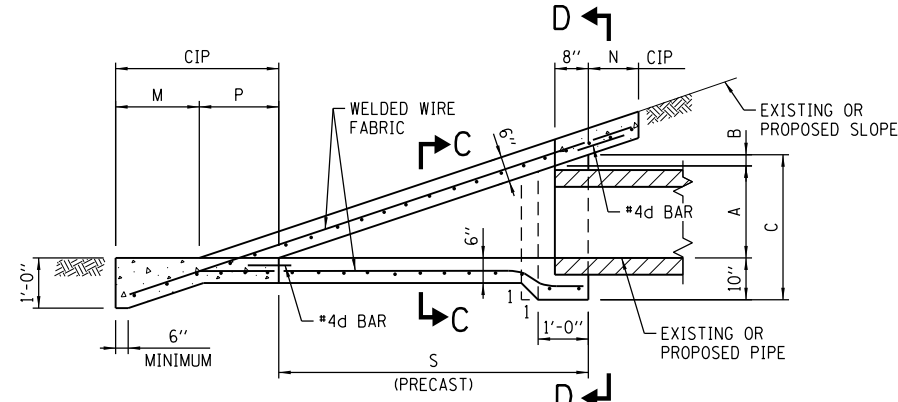
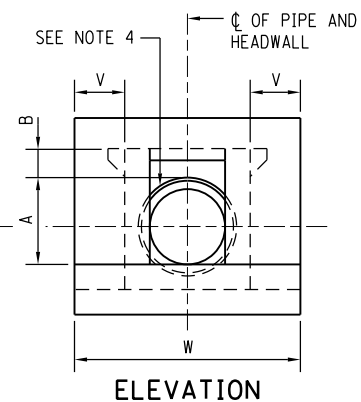

NOTES:

- THE CAST IN PLACE (CIP) SLOPED HEADWALL SHALL BE CONSTRUCTED FLUSH WITH EXISTING OR PROPOSED SLOPE.
- CLASS SI CONCRETE SHALL BE USED THROUGHOUT.
- WELDED WIRE FABRIC SHALL BE EPOXY COATED 6x6-W4xW4, 58 LBS. PER 100 SQ.FT.
- ALL REINFORCEMENT BARS SHOWN SHALL BE EPOXY COATED.
- BAR BENDING DETAILS ARE DIMENSIONED OUT TO OUT OF BARS.
- COVER FROM FACE OF CONCRETE TO FACE OF REINFORCEMENT BAR SHALL BE 3" FOR SURFACES FORMED AGAINST EARTH AND 2" FOR ALL OTHER SURFACES UNLESS OTHERWISE SHOWN.
- PRECAST UNIT USE IS OPTIONAL, THE ENTIRE STRUCTURE MAY BE CAST IN PLACE.
- AFTER THE PRECAST SLOPED HEADWALL HAS BEEN PLACED, THE SPACE BETWEEN THE HEADWALL AND PIPE SHALL BE COMPLETELY FILLED WITH AN APPROVED NON-SHRINK GROUT WITH A MINIMUM 28-DAY COMPRESSIVE STRENGTH OF 5000 PSI. THE COST FOR FURNISHING AND PLACING THE GROUT SHALL BE INCIDENTAL TO SLOPED HEADWALLS.
- THE SLOPED HEADWALL DETAILS SHOWN ON THIS DRAWING ARE FOR USE ONLY WITH PIPES HAVING DIAMETER OR SPAN OF 30" OR LESS.
- QUANTITIES FOR CONCRETE, WELDED WIRE FABRIC, AND REINFORCING STEEL SHOWN IN THE SCHEDULES OF QUANTITIES ARE BASED ON A "H" DIMENSION OF 0'-0" AND A 1:2 SLOPE.
- ALL SLOPES ARE EXPRESSED AS UNITS OF VERTICAL DISPLACEMENT TO UNITS OF HORIZONTAL DISPLACEMENT (V:H). CONTRACT 60I31 SHEET 893 OF 963
- I.D. DENOTES INSIDE DIAMETER OF PIPE. O.D. DENOTES OUTSIDE DIAMETER OF PIPE.

DATE	REVISIONS
6-1-2009	ADDED TABLE INFORMATION ADDED DIMENSION NOTATIONS TO SLOPED HEADWALL
3-1-2010	REVISED NOTES
1-1-2011	REVISED NOTES
2-7-2012	REVISED NOTES



SLOPED HEADWALLS
TYPE III DETAILS

STANDARD B10-05

APPROVED: *Paul Kovacs* CHIEF ENGINEER DATE 2-7-2012