

GALVANIZED STEEL COVER DETAIL

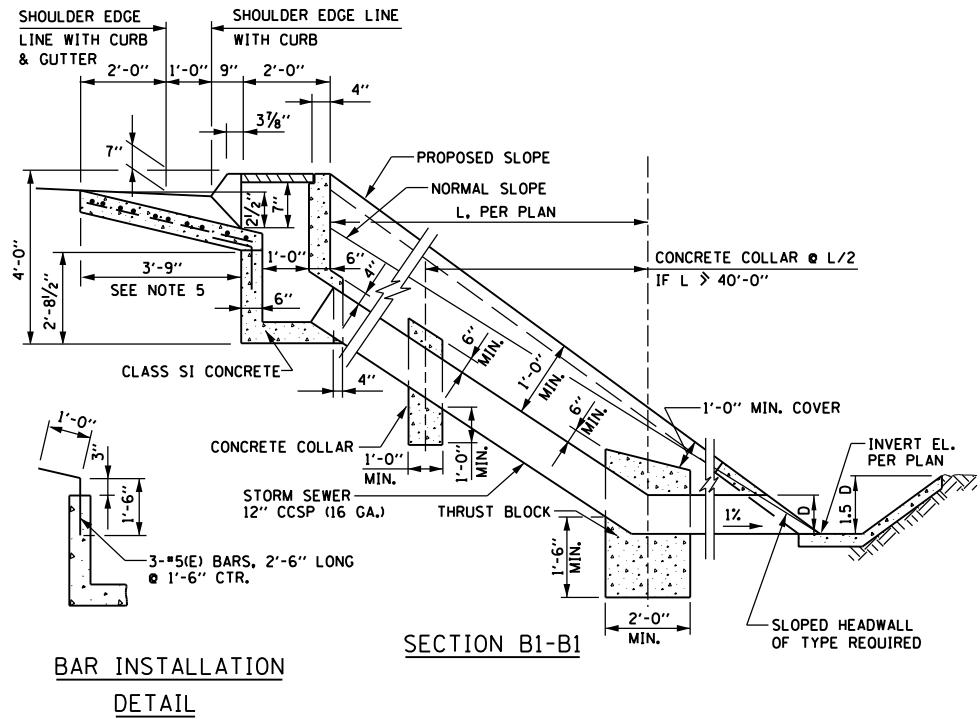
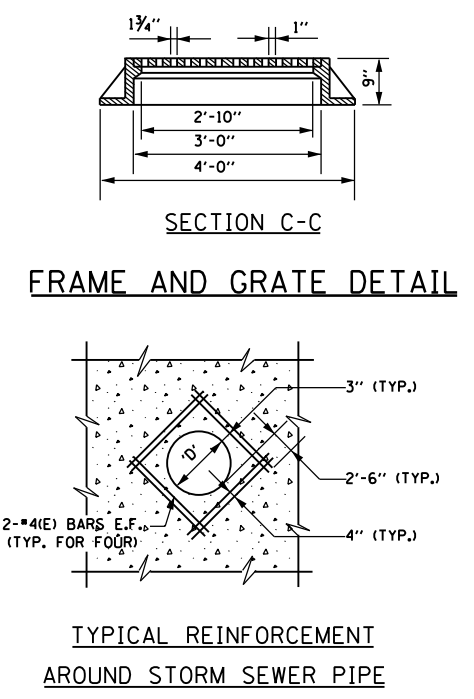
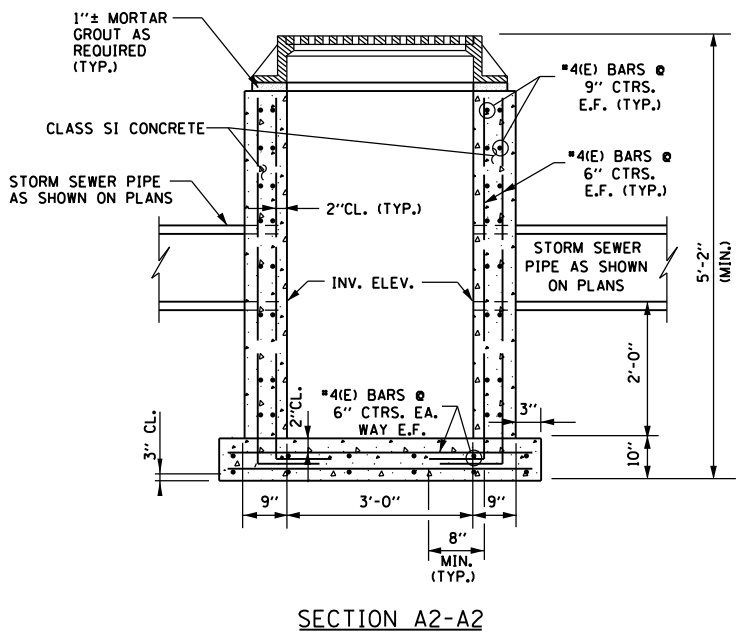
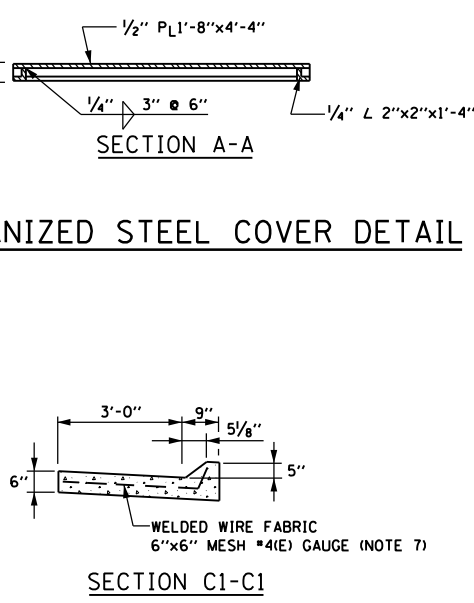

BAR INSTALLATION DETAIL

SLOPE DRAIN INLET

NOTES FOR SLOPE DRAIN INLET:

1. THE LOCATION OF THE SLOPE DRAIN INLET SHALL BE AS SHOWN ON THE PLANS OR AS DIRECTED BY THE ENGINEER. THE INLET MUST BE LOCATED IN THE FIELD TO CLEAR THE POST SPACING OF EXISTING OR PROPOSED GUARDRAIL. WHERE CONDITIONS REQUIRE THAT THE SLOPE DRAIN INLET BE LOCATED ADJACENT TO A GUARDRAIL ANCHOR INSTALLATION, THE SLOPED DRAIN INLET MUST BE CONSTRUCTED OUTSIDE THE LIMIT OF THE ANCHOR INSTALLATION.
2. INLET CONSTRUCTION EXCLUSIVE OF P.C.C. APRON SHALL BE COMPLETED PRIOR TO SHOULDER OVERLAY. CONSTRUCTION OF P.C.C. APRON SHALL FOLLOW SHOULDER OVERLAY.
3. THE MATERIALS AND CONSTRUCTION OF THE INLET SHALL CONFORM TO THE APPLICABLE PORTIONS OF THE STANDARD SPECIFICATIONS AND THE SPECIAL PROVISIONS.
4. THE CONCRETE CURB WITHIN THE P.C.C. APRON WILL TRANSITION TO MATCH THE SHAPE OF ABUTTING CURBS.
5. INCREASE NORMAL SHOULDER SLOPE WITHIN LIMITS OF P.C.C. APRON AND SHAPE TO DRAIN INTO INLET OPENING. THE INLET OPENING SHALL BE 2 1/2" BELOW THE NORMAL SHOULDER EDGE ELEVATION.
6. GALVANIZED STEEL COVER PLATE SHALL CONFORM TO THE REQUIREMENTS OF THE STANDARD SPECIFICATIONS. GALVANIZING SHALL BE IN ACCORDANCE WITH ASTM A123 (AASHTO M111).
7. EXPANDED METAL FABRIC OF EQUAL STRENGTH MAY BE USED IN LIEU OF WELDED WIRE FABRIC SUBJECT TO ENGINEER'S APPROVAL.
8. PRECAST CONCRETE UNITS FOR SLOPE DRAIN INLET WILL BE ACCEPTABLE PROVIDED THEY MEET ALL THE REQUIREMENTS SHOWN ON THIS DRAWING. FABRICATION DRAWINGS SHOWING PIPE OPENINGS, REINFORCEMENT AND OTHER PERTINENT DIMENSIONS WILL BE REQUIRED FOR EACH UNIT, FOR APPROVAL BY THE ENGINEER PRIOR TO FABRICATION.
9. REINFORCEMENT BARS AND WELDED WIRE FABRIC DESIGNATED (E) SHALL BE EPOXY COATED.

CATCH BASIN TYPE B

NOTES FOR CATCH BASIN TYPE B:

1. THE LOCATION OF THE CATCH BASIN SHALL BE AS SHOWN ON THE PLANS OR AS DIRECTED BY THE ENGINEER.
2. FOR MATERIALS AND CONSTRUCTION REQUIREMENTS OF THE CATCH BASIN, REFER TO THE STANDARD SPECIFICATIONS.
3. FRAME AND GRATE FOR CATCH BASIN TYPE B SHALL BE NEENAH FOUNDRY COMPANY TYPE R-3455C OR APPROVED EQUAL.
4. AT LOCATIONS WHERE EXISTING UNDERDRAINS AND/OR STORM SEWER PIPES ARE TO BE CONNECTED TO THE NEW CATCH BASIN, THE REMOVAL OF EXISTING PIPES, FURNISHING OF NEW PIPE SECTIONS OF THE SAME SIZE AND OTHER MATERIALS NECESSARY FOR THE CONNECTIONS SHALL BE INCIDENTAL TO THE COST OF CATCH BASIN TYPE B.
5. PRECAST CONCRETE UNITS FOR CATCH BASIN WILL BE ACCEPTABLE PROVIDED THEY MEET ALL THE REQUIREMENTS AS SHOWN ON THIS DRAWING. BASE EXTENSION OF 3" NOT REQUIRED FOR PRECAST UNITS. FABRICATION DRAWINGS SHOWING PIPE OPENINGS, REINFORCEMENT AND OTHER PERTINENT DIMENSIONS WILL BE REQUIRED FOR EACH UNIT, FOR APPROVAL BY THE ENGINEER PRIOR TO FABRICATION.
6. REINFORCEMENT BARS DESIGNATED (E) SHALL BE EPOXY COATED.

CONTRACT 60131 SHEET 891 OF 963



APPROVED *Paul Kovacs* CHIEF ENGINEER DATE 2-7-2012

DATE	REVISIONS
2-7-2012	REVISED REINFORCEMENT BARS

CATCH BASIN TYPE B AND SLOPE DRAIN INLET
STANDARD B7-01