

# TYPICAL APPLICATION

**THE USE OF CROSS STREET PAVEMENT SEPARATION JOINTS FOR SKEWED OR LARGE INTERSECTIONS WHERE JOINTS MAY NOT MATCH**

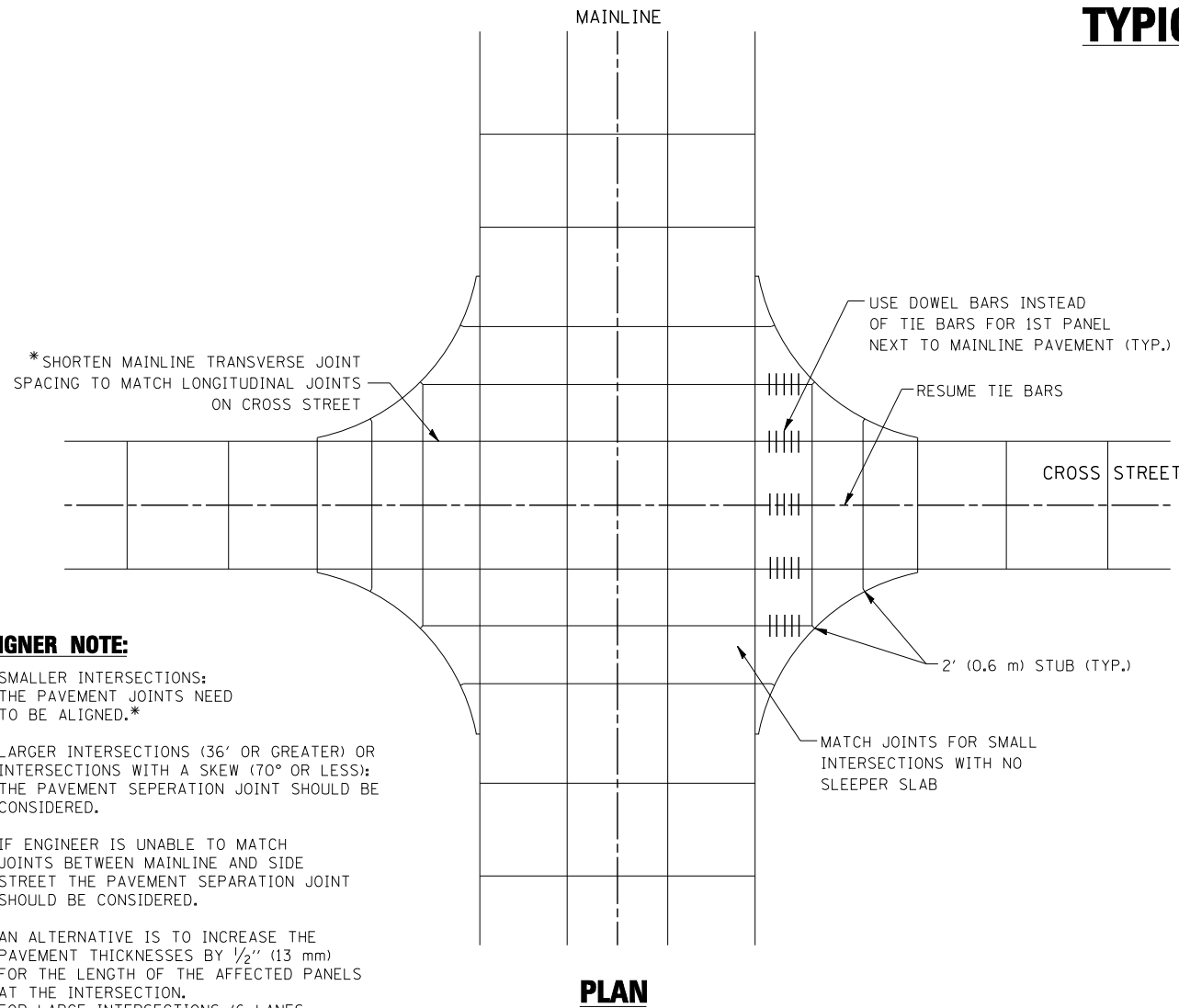

**PLAN**

**DESIGNER NOTE:**

1. SMALLER INTERSECTIONS: THE PAVEMENT JOINTS NEED TO BE ALIGNED.\*
2. LARGER INTERSECTIONS (36' OR GREATER) OR INTERSECTIONS WITH A SKEW (70° OR LESS): THE PAVEMENT SEPERATION JOINT SHOULD BE CONSIDERED.
3. IF ENGINEER IS UNABLE TO MATCH JOINTS BETWEEN MAINLINE AND SIDE STREET THE PAVEMENT SEPARATION JOINT SHOULD BE CONSIDERED.
4. AN ALTERNATIVE IS TO INCREASE THE PAVEMENT THICKNESSES BY 1/2" (13 mm) FOR THE LENGTH OF THE AFFECTED PANELS AT THE INTERSECTION. FOR LARGE INTERSECTIONS (6 LANES OR MORE) WHERE JOINTS CAN BE MATCHED, USE #8 (25) DOWEL BARS INSTEAD OF #8 (25) TIE BARS AT EDGE OF MAINLINE PAVEMENT WHEN NO PAVEMENT SEPARATION JOINTS USED.

**NOTE:**

1. JOINT FILLER SHALL CONSIST OF A SHEET OF 1/2" (13 mm) BITUMINOUS PREFORMED FIBER JOINT FILLER CONFORMING TO ARTICLE 1051.03 OF THE STANDARD SPECIFICATIONS.
2. THE JOINT SHALL BE SEALED WITH A HOT POUR JOINT SEALER CONFORMING TO ARTICLE 1050.02 OF THE STANDARD SPECIFICATIONS.
3. A SINGLE LAYER OF FELT ROOFING PAPER SHALL SERVE AS A BOND BREAKER.
4. JOINT SHALL CONTINUE THROUGH COMBINATION CURB & GUTTER OR PCC SHOULDER.
5. PAVEMENT SEPARATION JOINT IS TO BE PAID FOR AS "SLEEPER SLAB" AND IS TO BE MEASURED IN PLACE BY THE LINEAL FOOT.
6. BOND BREAKER AND 1/2" (13 mm) JOINT AND FILLER SHALL BE INCIDENTAL TO THE PAY ITEM "SLEEPER SLAB".

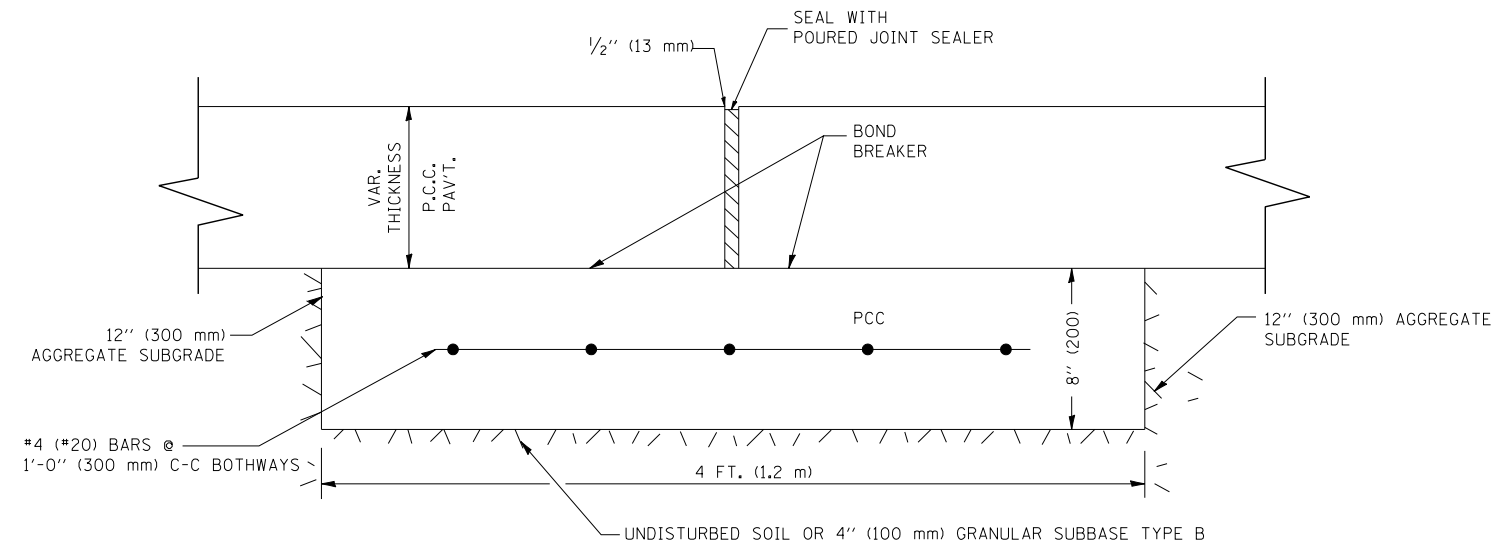
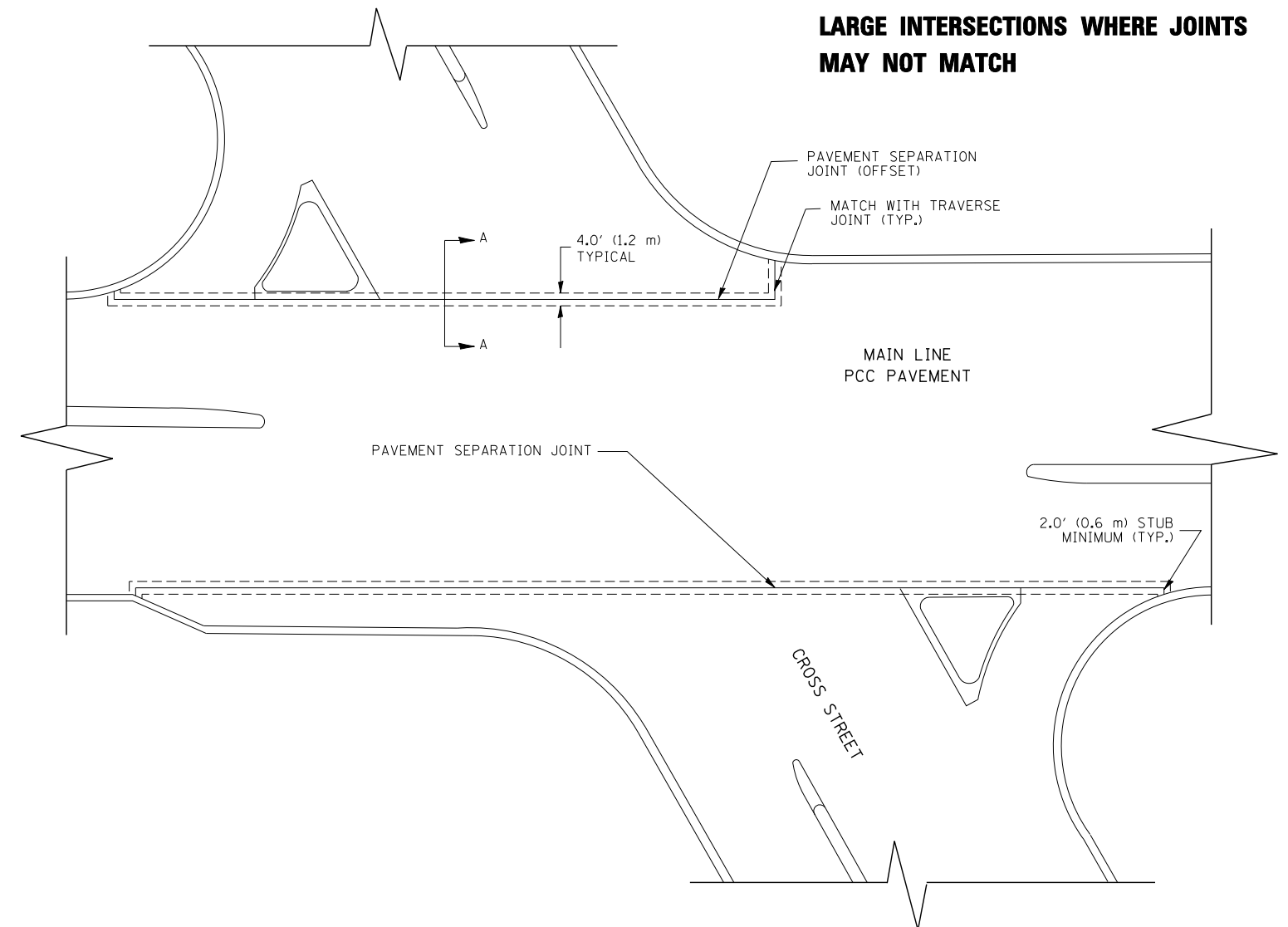

**PROPOSED SECTION A-A**

FILE NAME = bd52.dgn	USER NAME = leuss	DESIGNED - DRAWN -	REVISED - CADD 06-18-10 REVISED -
	PLOT SCALE = 49.9999' / IN.	CHECKED -	REVISED -
	PLOT DATE = 2/25/2011	DATE -	REVISED -

**STATE OF ILLINOIS  
DEPARTMENT OF TRANSPORTATION**

DETAIL OF PAVEMENT SEPARATION JOINT FOR JOINTED PCC PAVEMENTS AT INTERSECTIONS			
SCALE: NONE	SHEET NO. 1 OF 1 SHEETS	STA.	TO STA.

F.A. RTE.	SECTION	COUNTY	TOTAL SHEETS	SHEET NO.
338	(112 & 113)WRS-5	DUPAGE	963	704
<b>BD52</b>		CONTRACT NO. 60I31		
ILLINOIS FED. AID PROJECT				