

SECTION A-A
SB Bridge shown, NB Bridge similar

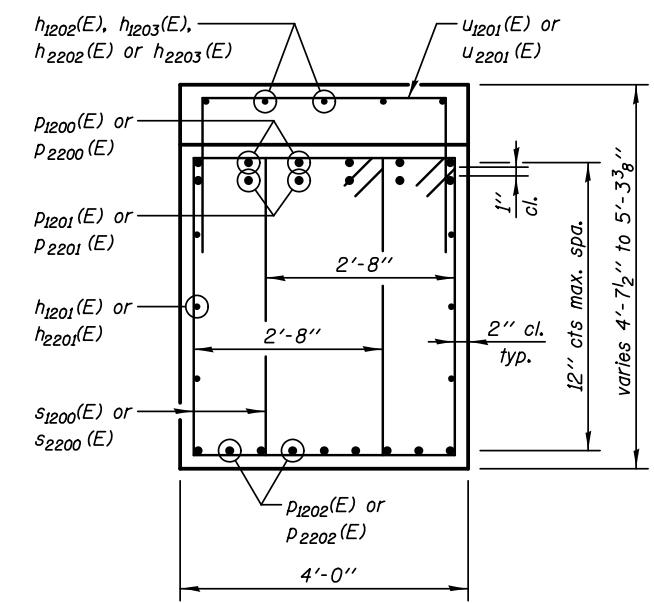

SECTION B-B
SB Bridge shown, NB Bridge similar

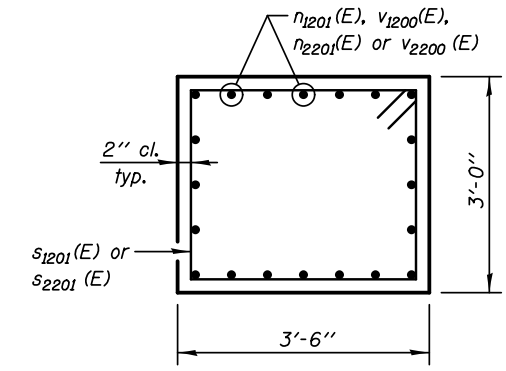

SECTION C-C

**SOUTHBOUND
BILL OF MATERIAL**

BAR	NO.	SIZE	LENGTH	SHAPE
d1200(E)	44	#8	4'-2"	U
h1200(E)	34	#6	28'-0"	
h1201(E)	12	#5	27'-5"	
h1202(E)	5	#5	22'-6"	
h1203(E)	5	#5	11'-11"	
n1200(E)	104	#6	17'-2"	U
n1201(E)	80	#8	9'-9"	U
p1200(E)	12	#9	31'-7"	L
p1201(E)	6	#9	32'-0"	
p1202(E)	27	#9	22'-6"	
s1200(E)	202	#5	14'-7"	□
s1201(E)	36	#4	12'-5"	□
t1200(E)	55	#5	8'-8"	
t1201(E)	48	#6	10'-0"	U
u1200(E)	24	#5	11'-8"	□
u1201(E)	33	#5	8'-8"	□
v1200(E)	80	#8	13'-2"	
w1200(E)	40	#5	29'-0"	
Reinforcement Bars, Epoxy Coated			LB	20420
Concrete Structures			Cu. Yd.	168.0
Structure Excavation			Cu. Yd.	148.0
Furnishing Steel Piles HP 14x73			Foot	1196.0
Driving Piles			Foot	1173.0
Test Pile Steel HP 14x73			Each	1
Concrete Sealer			Sq. Ft.	1985.0

**NORTHBOUND
BILL OF MATERIAL**

BAR	NO.	SIZE	LENGTH	SHAPE
d2200(E)	50	#8	4'-2"	U
h2200(E)	34	#6	31'-3"	
h2201(E)	12	#5	30'-8"	
h2202(E)	5	#5	22'-6"	
h2203(E)	5	#5	18'-5"	
n2200(E)	118	#6	17'-6"	U
n2201(E)	80	#8	9'-9"	U
p2200(E)	16	#9	34'-10"	L
p2201(E)	8	#9	35'-0"	
p2202(E)	33	#9	24'-8"	
s2200(E)	228	#5	14'-7"	□
s2201(E)	36	#4	12'-5"	□
t2200(E)	62	#5	8'-8"	
t2201(E)	56	#6	10'-0"	U
u2200(E)	24	#5	11'-8"	□
u2201(E)	40	#5	8'-8"	□
v2200(E)	80	#8	12'-7"	
w2200(E)	40	#5	32'-3"	
Reinforcement Bars, Epoxy Coated			LB	23410
Concrete Structures			Cu. Yd.	189.0
Structure Excavation			Cu. Yd.	155.0
Furnishing Steel Piles HP 14x73			Foot	1593.0
Driving Piles			Foot	1566.0
Test Pile Steel HP 14x73			Each	1
Concrete Sealer			Sq. Ft.	2157.0

A DIMENSIONS

BAR	A
n1200(E)	6'-9"
u1200(E)	4'-0"
u1201(E)	3'-0"
n2200(E)	6'-11"
u2200(E)	4'-0"
u2201(E)	3'-0"

BARS n1200(E), u1200(E) & u1201(E)
BARS n2200(E), u2200(E) & u2201(E)

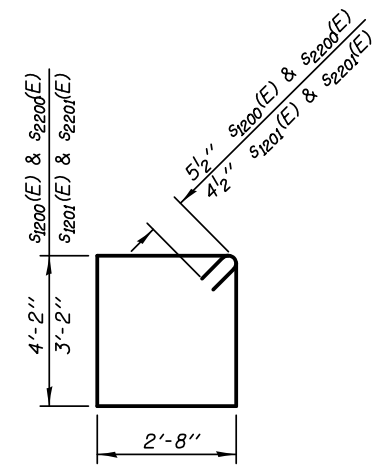

BARS s1200(E) & s1201(E)
BARS s2200(E) & s2201(E)

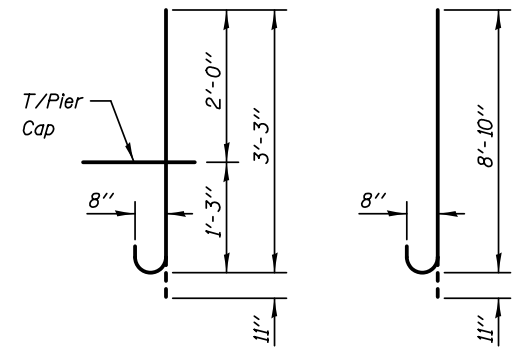

BAR d1200(E)
BAR d2200(E)

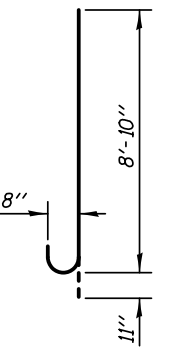

BAR n1201(E)
BAR n2201(E)

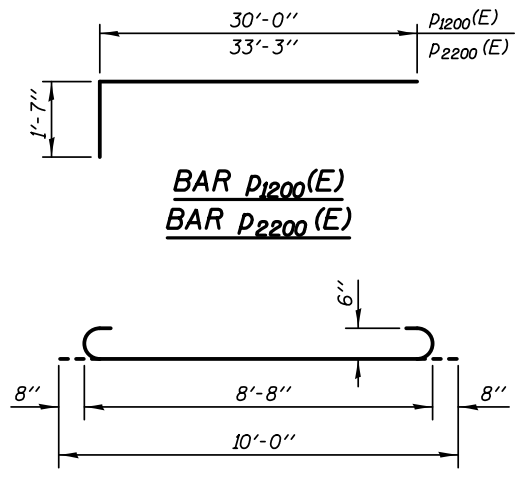

BAR t1201(E)
BAR t2201(E)