

ELEVATION OF BEAM AT PIER

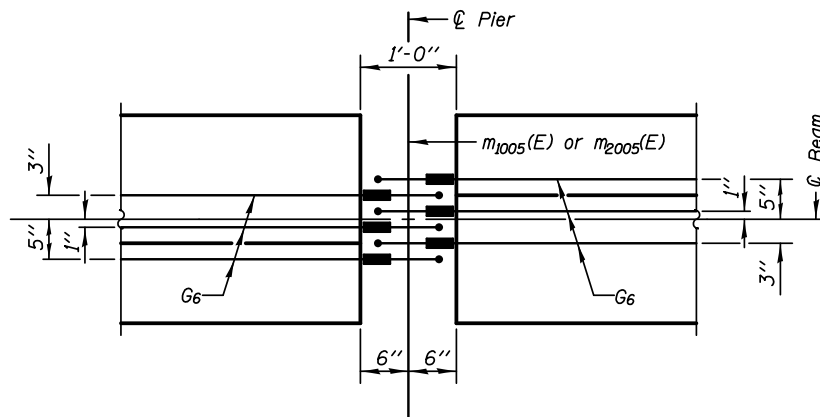

PLAN OF BEAM AT PIER

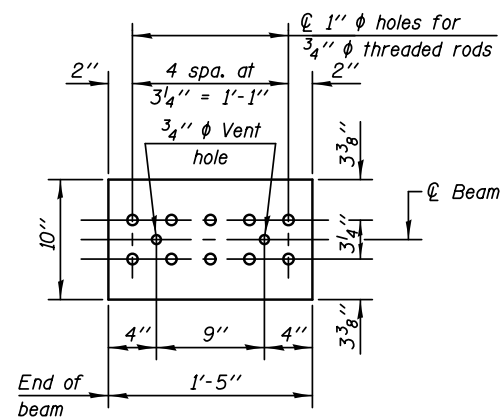

TOP PLATE

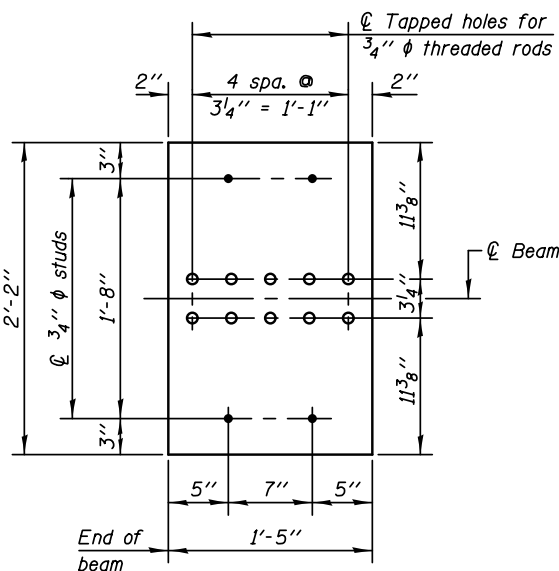

BOTTOM PLATE

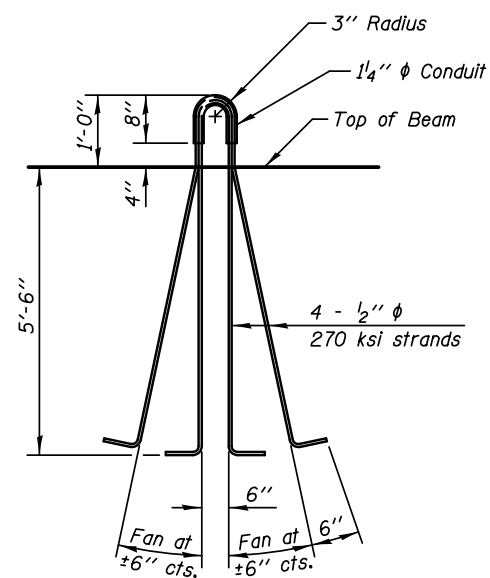

LIFTING LOOP DETAIL

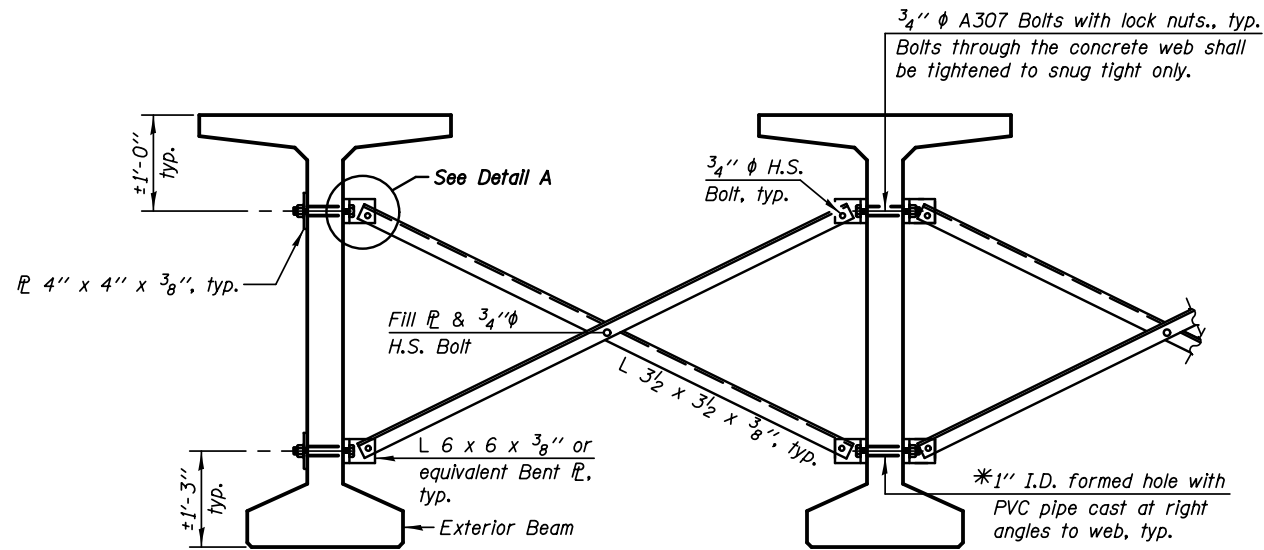

Permanent Bracing Notes:

All material for bracing shall be hot dip galvanized according to AASHTO M111 unless otherwise noted.

Two hardened washers are required for each set of oversized holes.

All holes shall be 1 5/16" φ unless otherwise noted.

5/16" x 3" x 3" plate washers are required over all slotted holes.

All bolts shall be galvanized according to AASHTO M232.

Bracing shall be installed as beams are erected and tightened as soon as possible during erection.

Permanent bracing shall not be paid for separately, but shall be included in the cost of Furnishing and Erecting Precast Prestressed Concrete Bulb T-Beams.

PERMANENT BRACING DETAILS FOR BULB-T BEAMS

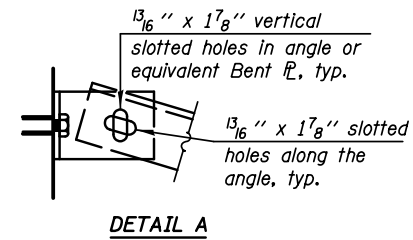

*Fabricator shall locate to miss strands within permissible tolerances.

NOTES

Inserts for 3/4" φ threaded dowel rods, when specified, are to be two strut, ferrule type for interior beams and single ferrule, flared loop type for exterior beams.

Prestressing steel shall be uncoated high strength, low relaxation 7-wire strand, Grade 270. The nominal diameter shall be 1/2" and the nominal cross-sectional area shall be 0.153 sq. in.

A minimum 2 1/2" φ lifting pin shall be used to engage the lifting loops during handling.

Tilt G₆ bars when necessary to maintain 1/2" clearance.

The top and bottom plates shall be AASHTO M270 Grade 50.

The bottom plates and studs shall be galvanized according to AASHTO M111. Top plates and threaded rods need not be galvanized.

Threaded rods shall be ASTM F 1554 Grade 55.

The G₆ bar assembly shall be capable of developing 125 percent of the yield strength of the grade 60 reinforcement bar components. The assembly shall allow completion of the splice without turning of the hook bar. The hook bar shall be threaded such that the entire coupler can be threaded onto the hook bar.

Beams requiring G₆ bar assemblies shall not be released from the fabricator until they have attained 45 days of age or older.

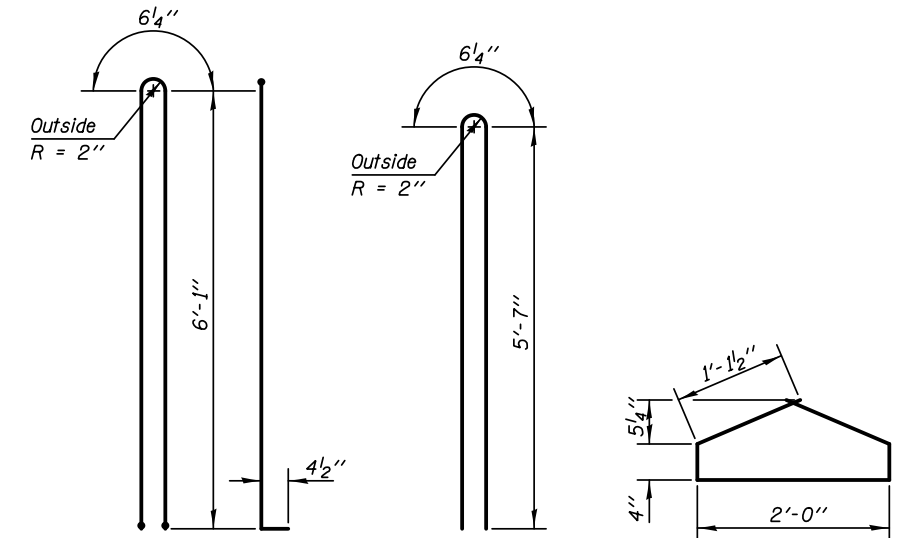

BAR G₁

BAR G₂

BAR G₄

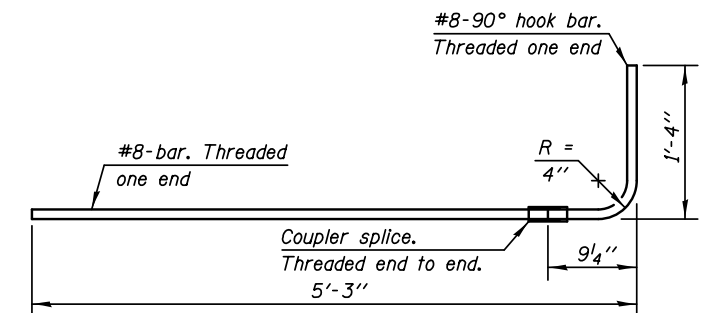

G₆ BAR ASSEMBLY

BILL OF MATERIAL

Item	Unit	Total
Furnishing and Erecting Precast Prestressed Concrete Bulb T-Beams, 72"	Foot	4256.0