

To determine "h": After all precast prestressed beams have been erected, elevations of the top flanges of the beams shall be taken at intervals shown on Sheet SA-13. These elevations subtracted from the "Theoretical Grade Elevations Adjusted for Dead Load Deflections" shown below, minus slab thickness, equals the fillet heights "h" above top flanges of beams.

FILLET HEIGHTS

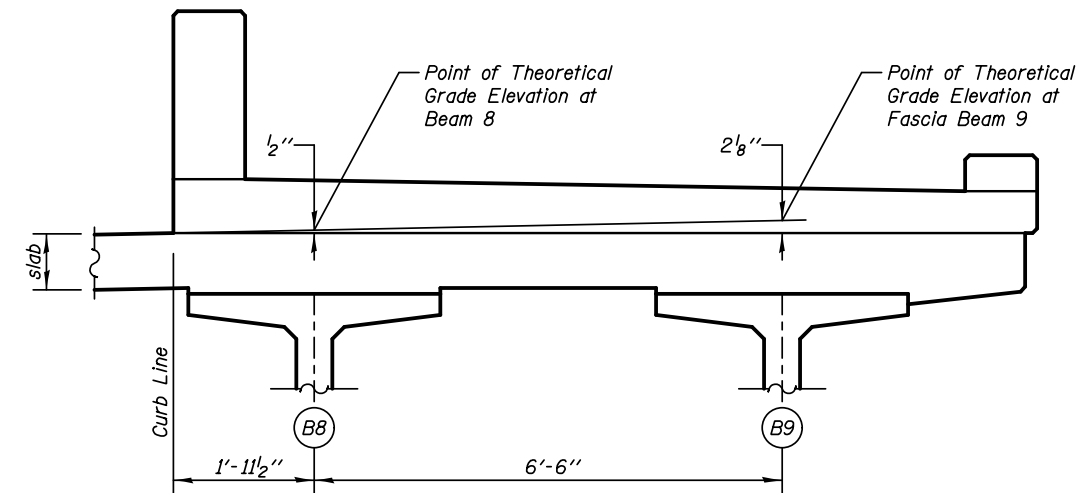

SECTION THRU SIDEWALK

P.G. LINE & @ NORTHBOUND IL 59

Location	Station	Offset	Theoretical Grade Elevations	Theoretical Grade Elevations Adjusted For Dead Load Deflection
Bk. S. Abut.	919+08.61	0.00	729.94	729.94
@ Brg. S. Abut	919+10.13	0.00	729.96	729.96
A	919+20.13	0.00	730.07	730.10
B	919+30.13	0.00	730.18	730.24
C	919+40.13	0.00	730.28	730.36
D	919+50.13	0.00	730.38	730.48
E	919+60.13	0.00	730.47	730.58
F	919+70.13	0.00	730.55	730.67
G	919+80.13	0.00	730.64	730.75
H	919+90.13	0.00	730.71	730.82
I	920+00.13	0.00	730.78	730.87
J	920+10.13	0.00	730.85	730.92
K	920+20.13	0.00	730.91	730.95
S. Brg. Pier	920+34.12	0.00	730.99	730.99
@ Pier	920+35.13	0.00	730.99	730.99
N. Brg. Pier	920+36.13	0.00	731.00	731.00
L	920+46.12	0.00	731.05	731.08
M	920+56.12	0.00	731.09	731.15
N	920+66.12	0.00	731.13	731.21
O	920+76.12	0.00	731.16	731.26
P	920+86.12	0.00	731.19	731.30
Q	920+96.12	0.00	731.21	731.33
R	921+06.12	0.00	731.23	731.35
S	921+16.12	0.00	731.24	731.35
T	921+26.12	0.00	731.25	731.34
U	921+36.12	0.00	731.25	731.32
V	921+46.12	0.00	731.25	731.29
@ Brg. N. Abut	921+60.13	0.00	731.24	731.24
Bk. N. Abut.	921+61.64	0.00	731.24	731.24

BEAM 1

Location	Station	Offset	Theoretical Grade Elevations	Theoretical Grade Elevations Adjusted For Dead Load Deflection
Bk. S. Abut.	919+08.67	0.46	729.95	729.95
@ Brg. S. Abut	919+10.19	0.46	729.97	729.97
A	919+20.19	0.46	730.08	730.11
B	919+30.19	0.46	730.19	730.25
C	919+40.19	0.46	730.29	730.37
D	919+50.19	0.46	730.39	730.49
E	919+60.19	0.46	730.48	730.59
F	919+70.19	0.46	730.56	730.68
G	919+80.19	0.46	730.65	730.76
H	919+90.19	0.46	730.72	730.83
I	920+00.19	0.46	730.79	730.88
J	920+10.19	0.46	730.86	730.93
K	920+20.19	0.46	730.92	730.96
S. Brg. Pier	920+34.19	0.46	731.00	731.00
@ Pier	920+35.19	0.46	731.00	731.00
N. Brg. Pier	920+36.19	0.46	731.01	731.01
L	920+46.19	0.46	731.06	731.09
M	920+56.19	0.46	731.10	731.16
N	920+66.19	0.46	731.14	731.22
O	920+76.19	0.46	731.17	731.27
P	920+86.19	0.46	731.20	731.31
Q	920+96.19	0.46	731.22	731.34
R	921+06.19	0.46	731.24	731.36
S	921+16.19	0.46	731.25	731.36
T	921+26.19	0.46	731.26	731.35
U	921+36.19	0.46	731.26	731.33
V	921+46.19	0.46	731.26	731.30
@ Brg. N. Abut	921+60.19	0.46	731.25	731.25
Bk. N. Abut.	921+61.70	0.46	731.25	731.25

BEAM 2

Location	Station	Offset	Theoretical Grade Elevations	Theoretical Grade Elevations Adjusted For Dead Load Deflection
Bk. S. Abut.	919+09.56	6.96	730.10	730.10
@ Brg. S. Abut	919+11.08	6.96	730.11	730.11
A	919+21.08	6.96	730.22	730.25
B	919+31.08	6.96	730.33	730.39
C	919+41.08	6.96	730.43	730.52
D	919+51.08	6.96	730.53	730.63
E	919+61.08	6.96	730.62	730.74
F	919+71.08	6.96	730.71	730.83
G	919+81.08	6.96	730.79	730.91
H	919+91.08	6.96	730.86	730.97
I	920+01.08	6.96	730.93	731.02
J	920+11.08	6.96	731.00	731.07
K	920+21.08	6.96	731.06	731.10
S. Brg. Pier	920+35.08	6.96	731.14	731.14
@ Pier	920+36.08	6.96	731.14	731.14
N. Brg. Pier	920+37.08	6.96	731.15	731.15
L	920+47.08	6.96	731.20	731.22
M	920+57.08	6.96	731.24	731.30
N	920+67.08	6.96	731.28	731.36
O	920+77.08	6.96	731.31	731.41
P	920+87.08	6.96	731.34	731.45
Q	920+97.08	6.96	731.36	731.48
R	921+07.08	6.96	731.38	731.50
S	921+17.08	6.96	731.39	731.50
T	921+27.08	6.96	731.40	731.49
U	921+37.08	6.96	731.40	731.47
V	921+47.08	6.96	731.40	731.44
@ Brg. N. Abut	921+61.08	6.96	731.38	731.38
Bk. N. Abut.	921+62.59	6.96	731.38	731.38

KNIGHT

Engineers & Architects

DESIGNED - WPM	REVISED
CHECKED - TB	REVISED
DRAWN - TB	REVISED
CHECKED - WPM	REVISED

STATE OF ILLINOIS
DEPARTMENT OF TRANSPORTATION

TOP OF SLAB ELEVATIONS (NB)
S.N. 022-2029 (SB) TOLLWAY B.N. 826
S.N. 022-2030 (NB) TOLLWAY B.N. 825

F.A.P. RTE.	SECTION	COUNTY	TOTAL SHEETS	SHEET NO.
338	(112 & 113) WRS-5	DUPAGE	963	598
CONTRACT NO. 60131				
ILLINOIS FED. AID PROJECT				

SHEET NO. SA-14 OF 63 SHEETS