

To determine "t": After all precast prestressed beams have been erected, elevations of the top flanges of the beams shall be taken at intervals shown on Sheet SA-09. These elevations subtracted from the "Theoretical Grade Elevations Adjusted for Dead Load Deflections" shown below, minus slab thickness, equals the fillet heights "t" above top flanges of beams.

FILLET HEIGHTS

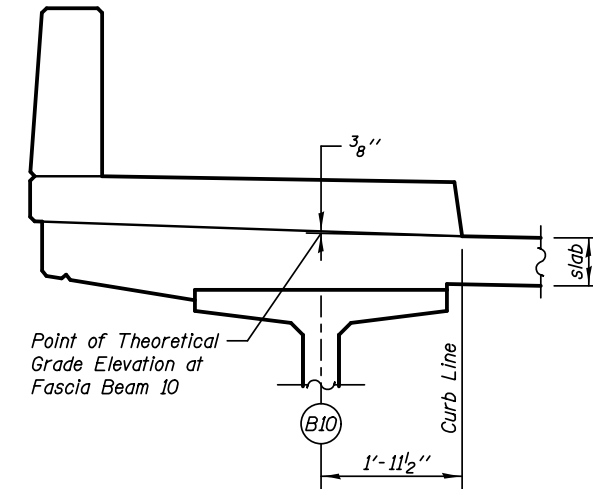

SECTION THRU SIDEWALK

BEAM 10

Location	Station	Offset	Theoretical Grade Elevations	Theoretical Grade Elevations Adjusted For Dead Load Deflection
Bk. S. Abut.	819+29.11	-45.96	731.26	731.26
@ Brg. S. Abut	819+30.62	-45.96	731.28	731.28
A	819+40.62	-45.96	731.38	731.41
B	819+50.62	-45.96	731.48	731.54
C	819+60.62	-45.96	731.57	731.65
D	819+70.62	-45.96	731.66	731.76
E	819+80.62	-45.96	731.74	731.86
F	819+90.62	-45.96	731.82	731.94
G	820+00.62	-45.96	731.89	732.01
H	820+10.62	-45.96	731.96	732.07
I	820+20.62	-45.96	732.02	732.11
J	820+30.62	-45.96	732.08	732.15
K	820+40.62	-45.96	732.13	732.17
S. Brg. Pier	820+54.62	-45.96	732.20	732.20
@ Pier	820+55.62	-45.96	732.20	732.20
N. Brg. Pier	820+56.62	-45.96	732.21	732.21
L	820+66.62	-45.96	732.25	732.27
M	820+76.62	-45.96	732.28	732.34
N	820+86.62	-45.96	732.31	732.39
O	820+96.62	-45.96	732.33	732.43
P	821+06.62	-45.96	732.35	732.47
Q	821+16.62	-45.96	732.37	732.49
R	821+26.62	-45.96	732.38	732.49
S	821+36.62	-45.96	732.38	732.49
T	821+46.62	-45.96	732.38	732.47
U	821+56.62	-45.96	732.37	732.44
V	821+66.62	-45.96	732.36	732.40
@ Brg. N. Abut	821+80.62	-45.96	732.34	732.34
Bk. N. Abut.	821+82.13	-45.96	732.33	732.33

BEAM 11

Location	Station	Offset	Theoretical Grade Elevations	Theoretical Grade Elevations Adjusted For Dead Load Deflection
Bk. S. Abut.	819+30.00	-39.46	731.13	731.13
@ Brg. S. Abut	819+31.51	-39.46	731.15	731.15
A	819+41.51	-39.46	731.25	731.28
B	819+51.51	-39.46	731.35	731.41
C	819+61.51	-39.46	731.44	731.53
D	819+71.51	-39.46	731.53	731.63
E	819+81.51	-39.46	731.61	731.73
F	819+91.51	-39.46	731.69	731.81
G	820+01.51	-39.46	731.76	731.88
H	820+11.51	-39.46	731.83	731.94
I	820+21.51	-39.46	731.89	731.98
J	820+31.51	-39.46	731.95	732.02
K	820+41.51	-39.46	732.00	732.04
S. Brg. Pier	820+55.51	-39.46	732.07	732.07
@ Pier	820+56.51	-39.46	732.07	732.07
N. Brg. Pier	820+57.51	-39.46	732.07	732.07
L	820+67.51	-39.46	732.11	732.14
M	820+77.51	-39.46	732.15	732.20
N	820+87.51	-39.46	732.18	732.26
O	820+97.51	-39.46	732.20	732.30
P	821+07.51	-39.46	732.22	732.33
Q	821+17.51	-39.46	732.23	732.35
R	821+27.51	-39.46	732.24	732.36
S	821+37.51	-39.46	732.24	732.35
T	821+47.51	-39.46	732.24	732.33
U	821+57.51	-39.46	732.24	732.31
V	821+67.51	-39.46	732.23	732.27
@ Brg. N. Abut	821+81.51	-39.46	732.20	732.20
Bk. N. Abut.	821+83.02	-39.46	732.20	732.20

BEAM 12

Location	Station	Offset	Theoretical Grade Elevations	Theoretical Grade Elevations Adjusted For Dead Load Deflection
Bk. S. Abut.	819+30.88	-32.96	731.01	731.01
@ Brg. S. Abut	819+32.40	-32.96	731.02	731.02
A	819+42.40	-32.96	731.13	731.16
B	819+52.40	-32.96	731.22	731.28
C	819+62.40	-32.96	731.32	731.40
D	819+72.40	-32.96	731.40	731.50
E	819+82.40	-32.96	731.49	731.60
F	819+92.40	-32.96	731.56	731.68
G	820+02.40	-32.96	731.63	731.75
H	820+12.40	-32.96	731.70	731.81
I	820+22.40	-32.96	731.76	731.85
J	820+32.40	-32.96	731.82	731.88
K	820+42.40	-32.96	731.87	731.91
S. Brg. Pier	820+56.40	-32.96	731.93	731.93
@ Pier	820+57.40	-32.96	731.94	731.94
N. Brg. Pier	820+58.40	-32.96	731.94	731.94
L	820+68.40	-32.96	731.98	732.01
M	820+78.40	-32.96	732.01	732.07
N	820+88.40	-32.96	732.04	732.12
O	820+98.40	-32.96	732.07	732.17
P	821+08.40	-32.96	732.09	732.20
Q	821+18.40	-32.96	732.10	732.22
R	821+28.40	-32.96	732.11	732.22
S	821+38.40	-32.96	732.11	732.22
T	821+48.40	-32.96	732.11	732.20
U	821+58.40	-32.96	732.10	732.17
V	821+68.40	-32.96	732.09	732.13
@ Brg. N. Abut	821+82.40	-32.96	732.06	732.06
Bk. N. Abut.	821+83.91	-32.96	732.06	732.06