

SHARED USE PATH JOINTING DETAIL

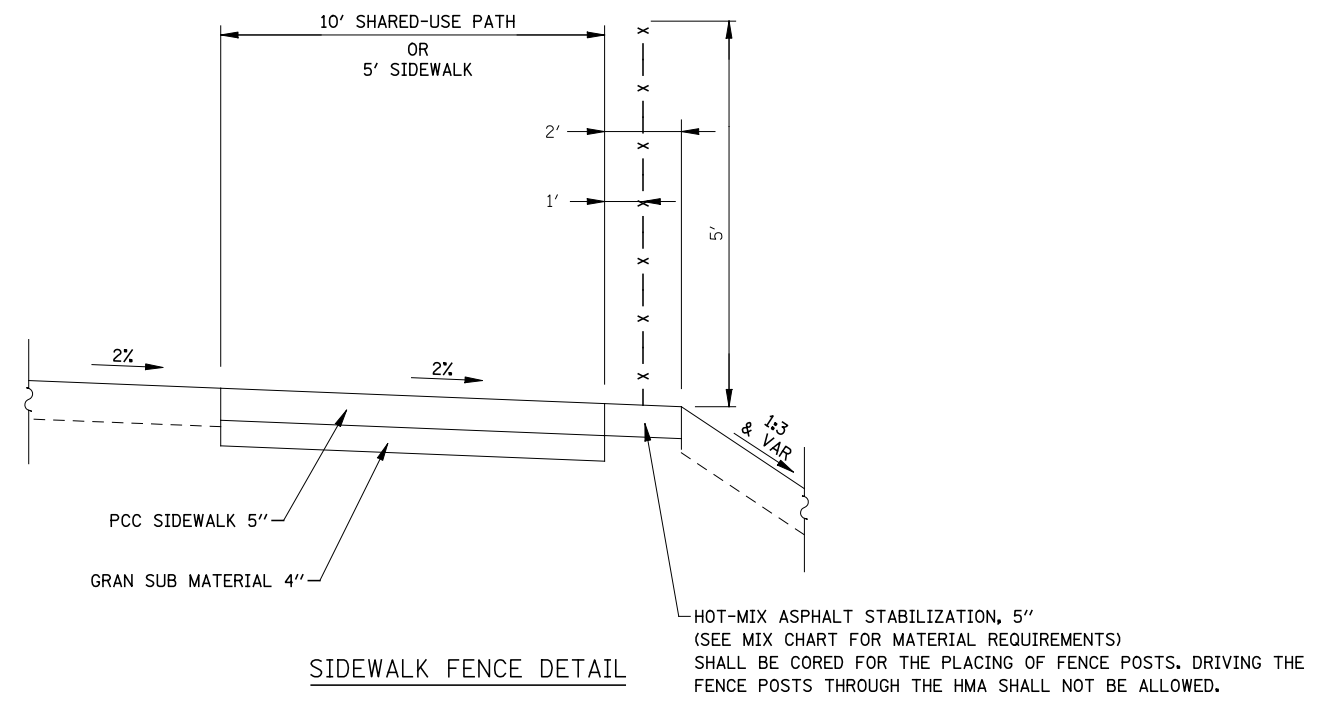

SIDEWALK FENCE DETAIL

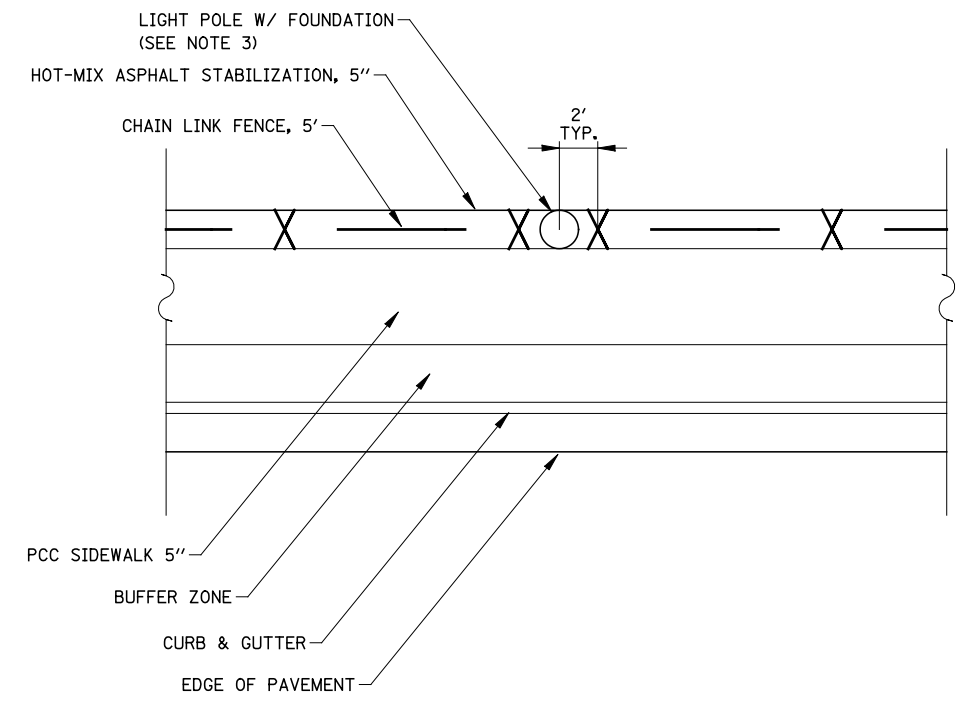

PLAN VIEW
FENCE INTERSECTING WITH LIGHT POLES

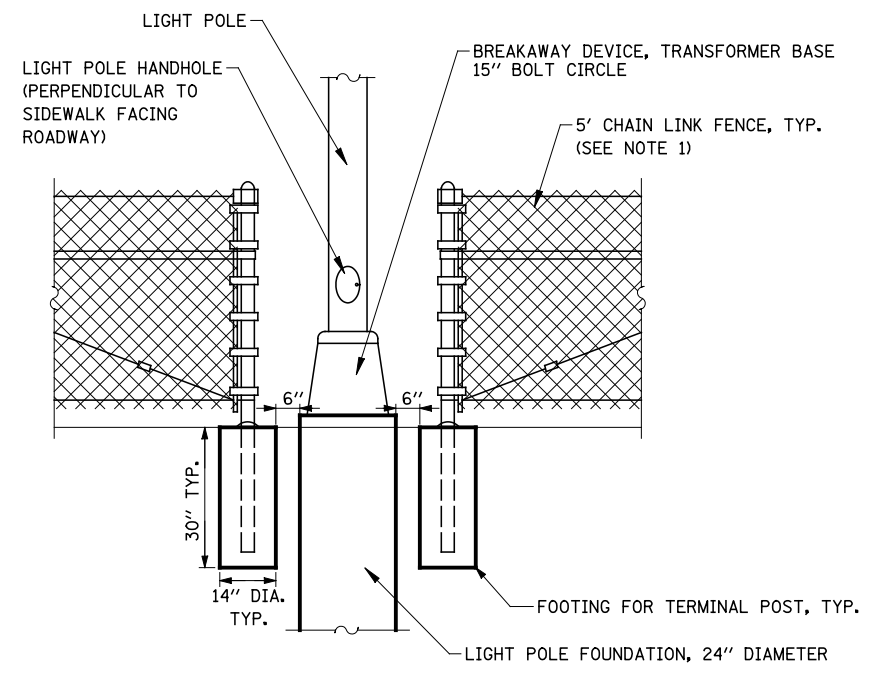

ELEVATION DETAIL
FENCE INTERSECTING WITH LIGHT POLES

- NOTES:**
1. SEE IDOT HIGHWAY STANDARD 664001 FOR ADDITIONAL DETAILS ON CHAIN LINK FENCE.
 2. TOOLED JOINTS SHALL NOT BE ALLOWED ON SHARED USE PATH.
 3. SEE LIGHTING PLANS FOR LOCATIONS OF PROPOSED LIGHT POLES.

FILE NAME =	USER NAME = #USER#	DESIGNED <i>PJO</i>	REVISED -	STATE OF ILLINOIS DEPARTMENT OF TRANSPORTATION	SIDEWALK / SHARED-USE PATH / FENCE DETAILS	F.A.P. RTE.	SECTION	COUNTY	TOTAL SHEETS	SHEET NO.	
#FILEL#		DRAWN <i>KES</i>	REVISED -			338	(112 & 113) WRS-5	DUPAGE	963	296	
PLOT SCALE = #SCALE#		CHECKED <i>JCM</i>	REVISED -			CONTRACT NO. 60I31					
PLOT DATE = #DATE#		DATE <i>10/15/2012</i>	REVISED -			SCALE:	SHEET NO. 8 OF 8 SHEETS	STA.	TO STA.	ILLINOIS FED. AID PROJECT	