

PROJECT ENGINEER: JIM MILLER  
PHONE: 309-671-3451

DESIGNER: CLARK JONES  
PHONE: 309-671-3452

**INDEX OF SHEETS:**

- 1. COVER SHEET
- 2. COMMITMENTS & GENERAL NOTES
- 3. SUMMARY OF QUANTITIES
- 4. TYPICAL SECTIONS
- 5. SCHEDULE OF QUANTITIES
- 6. GENERAL PLAN & ELEVATION
- 7. TRAFFIC CONTROL STAGING
- 8&9. EXISTING & REMOVAL SHEETS
- 10-12. PROPOSED PLAN SHEETS
- 13&14. CROSS SECTIONS
- 15. GABION DETAIL
- 16. DEWATERING SYSTEM DETAILS
- 16A.-16D. REMOVE AND REERECT STEEL PLATE BEAM GUARDRAIL

**STANDARDS:**

- 701001-01 701206-01
- 701006-02 701901
- 701201-02

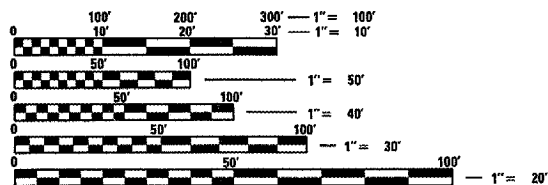

FULL SIZE PLANS HAVE BEEN PREPARED USING STANDARD ENGINEERING SCALES. REDUCED SIZED PLANS WILL NOT CONFORM TO STANDARD SCALES. IN MAKING MEASUREMENTS ON REDUCED PLANS, THE ABOVE SCALES MAY BE USED.

J.U.L.I.E.  
JOINT UTILITY LOCATION INFORMATION FOR EXCAVATION  
1-800-892-0123

CONTRACT NO. 68515 . CAT. NO. 032781-00D

STATE OF ILLINOIS  
DEPARTMENT OF TRANSPORTATION  
DIVISION OF HIGHWAYS  
**PROPOSED  
HIGHWAY PLANS**

FAS ROUTE 1380 (IL. 91)  
D4 SCOUR MITIGATION 2008  
PEORIA COUNTY  
C-94-129-05

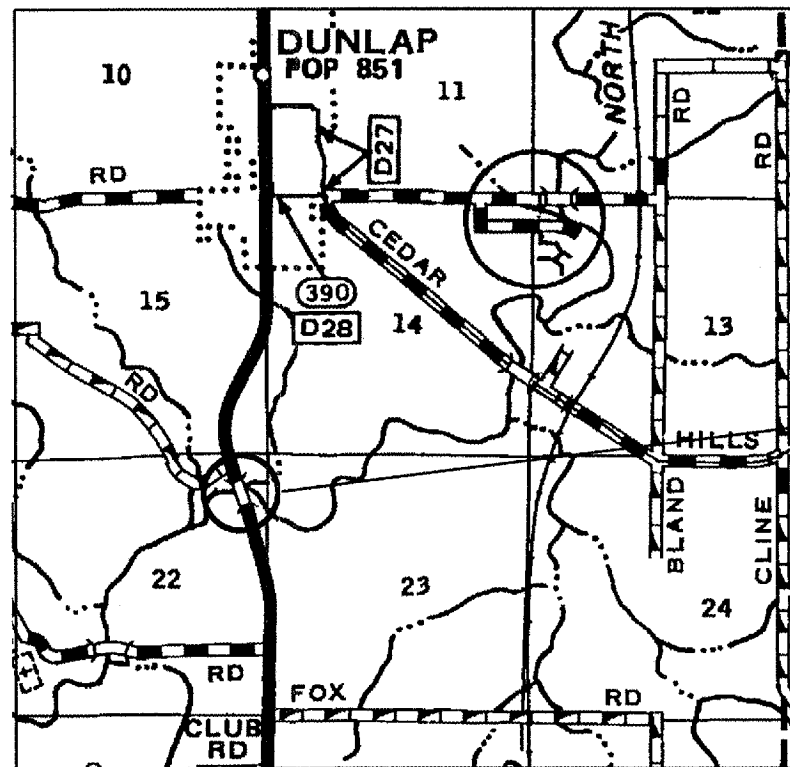

SCOUR MITIGATION AT STRUCTURE CARRYING  
IL 91 OVER KICKAPOO CREEK (SN 072-0155),  
1.5 MILES SOUTH OF DUNLAP.

F.A.S. RTE.	SECTION	COUNTY	TOTAL SHEETS	SHEET NO.
1380		PEORIA	16	1
				+4 20

D-94-104-05

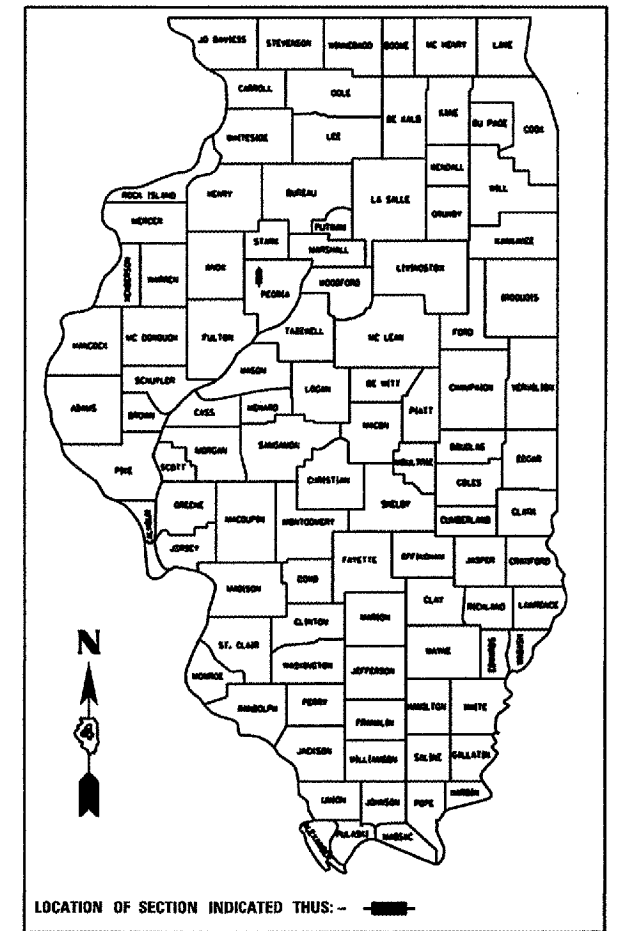

STATE OF ILLINOIS  
DEPARTMENT OF TRANSPORTATION  
DIVISION OF HIGHWAYS

SUBMITTED Nov 2, 2007

[Signature]  
REGIONAL ENGINEER

Dec 7, 2007  
[Signature]  
ENGINEER OF DESIGN AND ENVIRONMENT

Dec 7, 2007  
[Signature]  
DIRECTOR, DIVISION OF HIGHWAYS

**PRINTED BY THE AUTHORITY  
OF THE STATE OF ILLINOIS**

F.A.S. RTE.	SECTION	COUNTY	TOTAL SHEETS	SHEET NO.
1380	*	PEORIA	16	2
STA. 46+00		TO STA. 49+00		
FED. ROAD DIST. NO. 4 ILLINOIS FED. AID PROJECT				

D4 SCOUR MITIGATION 2008

# GENERAL NOTES

Plan dimensions and details relative to existing structure have been taken from existing plans and are subject to nominal construction variations. It shall be the Contractor's responsibility to verify such dimensions and details in the field and make necessary approved adjustments prior to construction or ordering of materials. Such variations shall not be cause for additional compensation for a change in the scope of the work. However, the Contractor will be paid for the quantity actually furnished at the unit price bid for the work.

Commitments are not to be altered without the written approval of all parties to which the commitment was made.

The Contractor shall be responsible for diverting the water flow from the construction area of each site. The Contractor may use either method of dewatering as described in the Dewatering Special Provision.

It is anticipated that the majority of this work will not require highway traffic lane closures. Lane closures will be permitted on a limited basis and are restricted to one-lane daytime only closures in accordance to IDOT Standard 701201.

During site preparation, areas below the final grade shall be brought to grade by placing compacted layers of Granular Subbase Material, Type C; areas of soft or otherwise unsuitable subgrade soils shall be excavated and replaced with compacted layers of Granular Subbase Material, Type C. Removal and replacement of unsuitable material shall be as directed by the Engineer and will be paid for in accordance to Article 109.04 (Force Account Basis) of the Standard Specifications. An assumed quantity for Granular Subbase Material, Type C, is included as part of each structure's mitigation details.

Layout of scour protection systems may be varied in the field to suit ground conditions as directed by the engineer.

All areas disturbed during construction shall be graded, fertilized, seeded and mulched as directed by the Engineer. Sections 250 and 251 of the Standard Specifications shall govern this work.

GABION ANCHOR STAKE layout shown on plan sheets is for information and estimation purposes only. Actual layout shall be determined in the field by the Contractor and approved by the Engineer and shall conform to the procedures stated in the special provisions.

# COMMITMENTS

The United States Army Corps of Engineers (USACOE), the Illinois Environmental Protection Agency and the Illinois Department of Natural Resources, Office of Water Resources have all issued permits authorizing the work shown in these plans. Copies of the permits will be found in the Special Provisions. Any conditions set forth in these permits for the work to be completed shall followed by the Contractor. At the conclusion of the job, the Engineer shall fill out & return the "Completed Work Certification" to the USACOE.

REVISIONS		ILLINOIS DEPARTMENT OF TRANSPORTATION
NAME	DATE	
		<b>COMMITMENTS &amp; GENERAL NOTES</b>  SCALE: VERT.      DRAWN BY CEJ HORIZ.              CHECKED BY DATE 05-01-2006

PLOT DATE \* NOTES \*  
 FILE NAME \* FILE # \*  
 PLOT SCALE \* SCALE \*  
 REFERENCE \* REF \*

F.A.S. RTE.	SECTION	COUNTY	TOTAL SHEETS	SHEET NO.
1380	*	PEORIA	16	3
STA. 46+00		TO STA. 49+00		
FED. ROAD DIST. NO. 4 ILLINOIS FED. AID PROJECT				

D4 SCOUR MITIGATION 2008

# SUMMARY OF QUANTITIES

100% STATE SAFETY-2A PEORIA COUNTY				
CODE NO.	ITEM	UNIT	RURAL	TOTAL
20200100	EARTH EXCAVATION	CU YD	113	113
20300100	CHANNEL EXCAVATION	CU YD	52	52
25000210	SEEDING, CLASS 2	ACRE	1.0	1.0
25000400	NITROGEN FERTILIZER NUTRIENT	POUND	90	90
25000500	PHOSPHORUS FERTILIZER NUTRIENT	POUND	90	90
25000600	POTASSIUM FERTILIZER NUTRIENT	POUND	90	90
28100209	STONE RIPRAP, CLASS A5	TON	690	690
28200200	FILTER FABRIC	SQ YD	290	290
28400100	GABIONS	CU YD	191	191
31101900	SUB-BASE GRANULAR MATERIAL, TYPE C	TON	34	34
63301000	REMOVE AND RE-ERECT STEEL PLATE BEAM GUARD RAIL	FOOT	100	100
70100450	TRAFFIC CONTROL AND PROTECTION, STANDARD 701201	LSUM	1.0	1.0
X0301852	DEWATERING STRUCTURE NO. 1	EACH	1.0	1.0
X0322584	REVTMENT MAT REMOVAL	SQ YD	614	614
X0323655	GABION ANCHOR STAKE	EACH	82	82
67100100	MOBILIZATION	L SUM	1	1

PLOT DATE \*  
FILE NAME \*  
PLOT SCALE \*  
REFERENCE \*  
BRIEF

REVISIONS	
NAME	DATE

ILLINOIS DEPARTMENT OF TRANSPORTATION

## SUMMARY OF QUANTITIES

SCALE: VERT.  
DATE: HORIZ.

DRAWN BY MJH  
CHECKED BY

F.A.S. RTE.	SECTION	COUNTY	TOTAL SHEETS	SHEET NO.
1380		PEORIA	16	4
STA. 46+00		TO STA. 49+00		
FED. ROAD DIST. NO. 4 ILLINOIS FED. AID PROJECT				

D4 SCOUR MITIGATION 2008

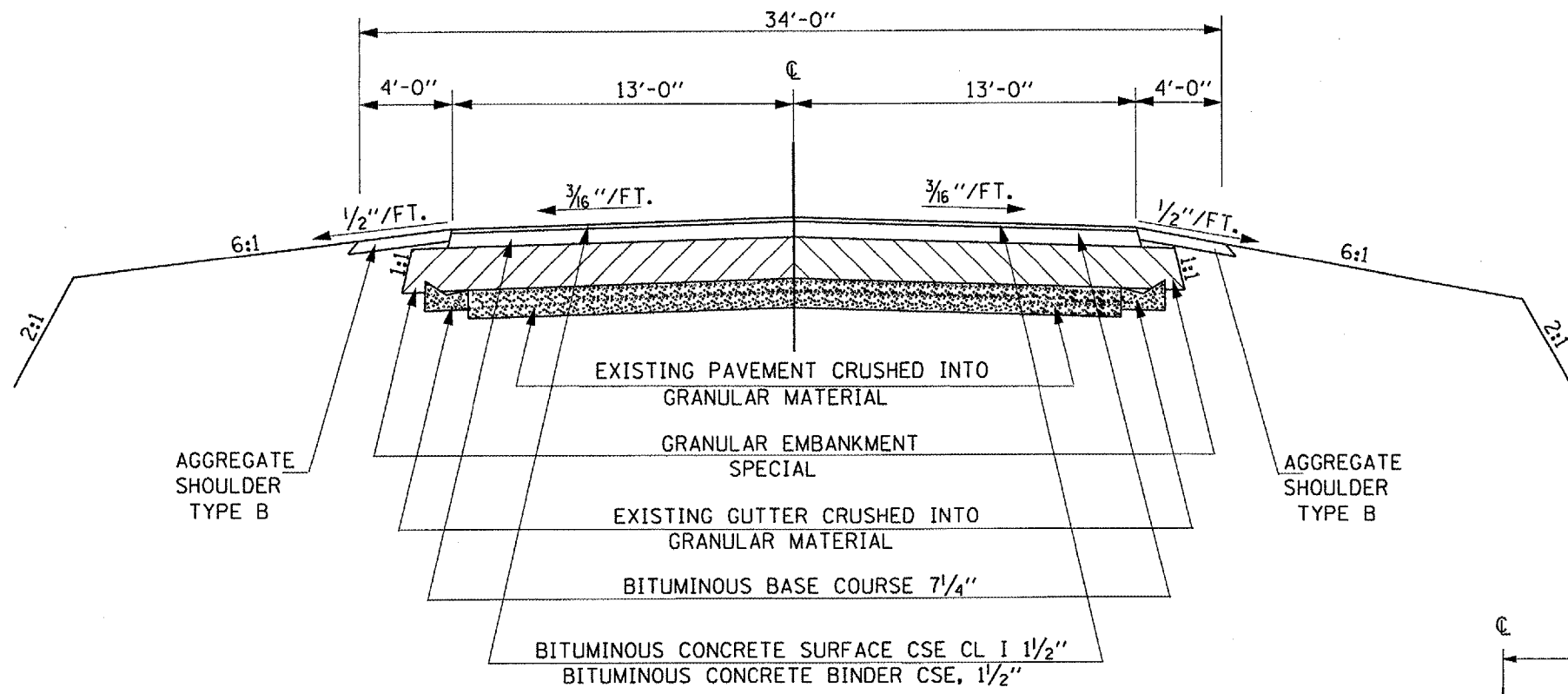

**BRIDGE APPROACH CROSS SECTION**

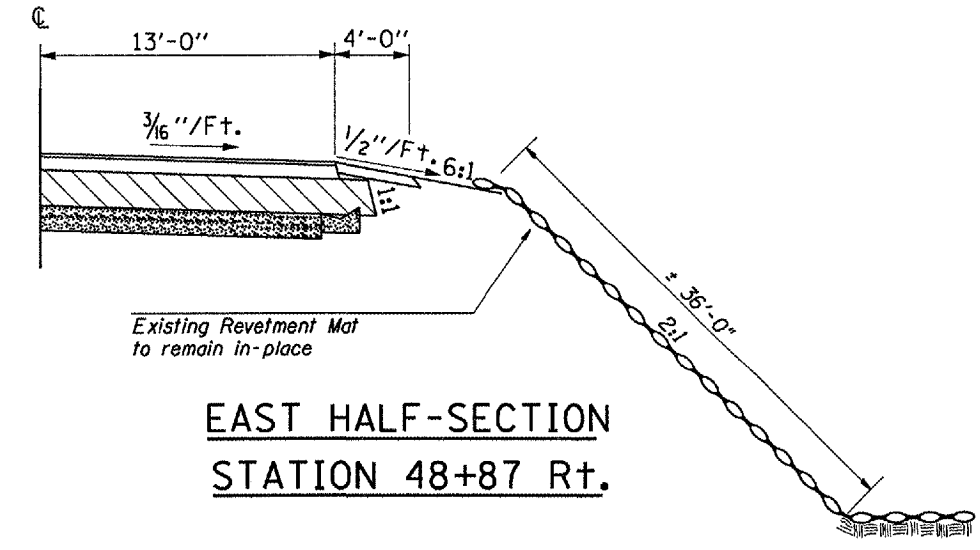

**EAST HALF-SECTION STATION 48+87 Rt.**

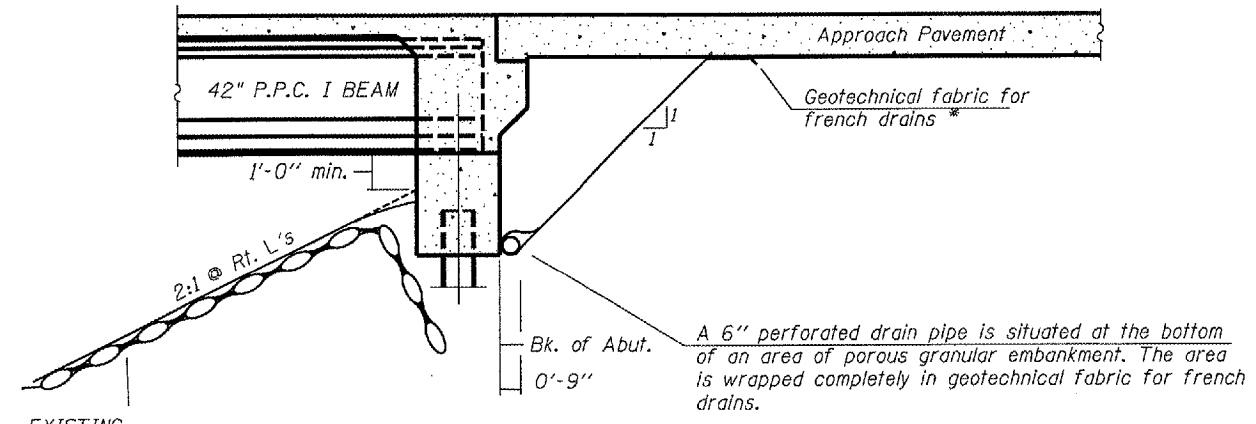

**ABUTMENT CROSS SECTION**

Structure (SN 072-0155) carrying IL 91 over Kickapoo Creek 1.5 mi.S.of Dunlap

REVISIONS	
NAME	DATE

ILLINOIS DEPARTMENT OF TRANSPORTATION

**TYPICAL SECTIONS**

SCALE: VERT. HORIZ. DATE

DRAWN BY MAJH CHECKED BY

DATE  
FILE NAME  
PLOT SCALE  
REFERENCE



F.A.S. RTE.	SECTION	COUNTY	TOTAL SHEETS	SHEET NO.
1380	*	PEORIA	16	6
STA. 46+46.00		TO STA. 48+41.00		
FED. ROAD DIST. NO. 4 ILLINOIS FED. AID PROJECT				
• D4 SCOUR MITIGATION 2008				

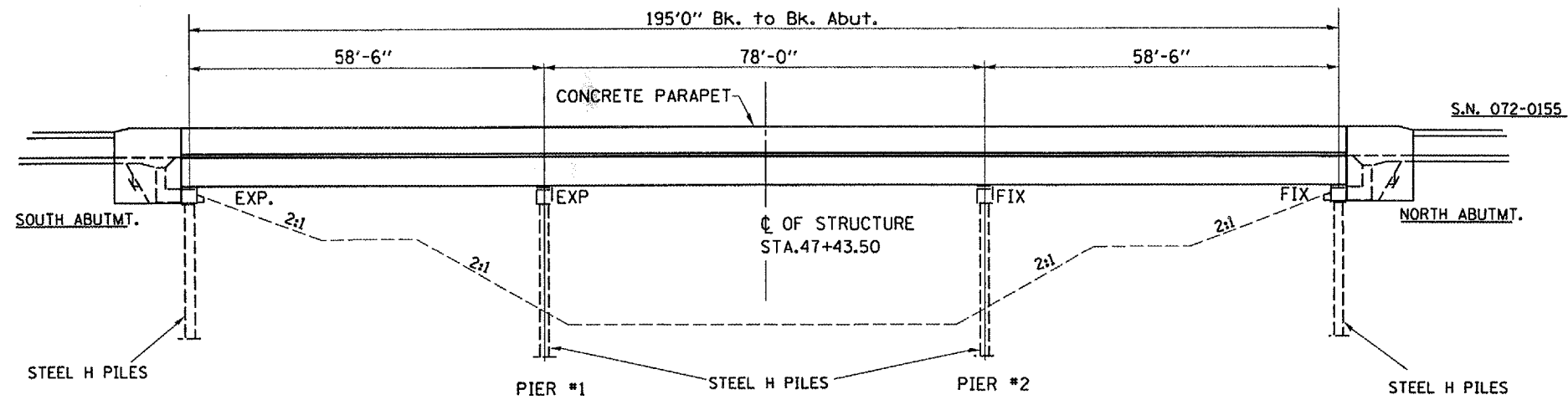

**ELEVATION**

PROPOSED R.O.W. LINES = 75'-0"

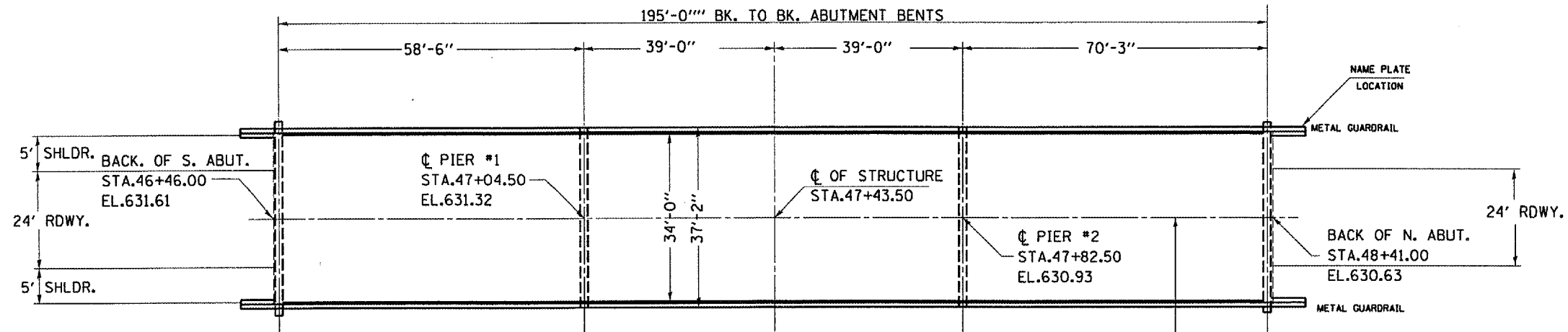

**PLAN VIEW**

PROPOSED R.O.W. LINES = 75'-0"

SUGGESTED SEQUENCE OF OPERATIONS

1. Install dewatering system and divert water flow from the construction area.
2. Excavate to the lines, grades, contours, and dimensions shown. The prepared area shall be inspected and approved by the Engineer before further work can take place.
3. Install filter fabric on the graded surfaces as shown on the drawings.
4. Install scour countermeasures. See detail sheets for specific installation procedures.
5. Remove dewatering system. Grade and seed ground disturbed during construction.

Structure (SN 072-0155) carrying IL 91 over Kickapoo Creek 1.5mi. S.of Dunlap

REVISIONS	
NAME	DATE

ILLINOIS DEPARTMENT OF TRANSPORTATION

**GENERAL PLAN AND ELEVATION**

SCALE: VERT. HORIZ. DATE 05-25-2004

DRAWN BY MJH CHECKED BY

PLT DATE \* NOTES  
FILE NAME \* FILES  
PLT SCALE \* SCALES  
REFERENCE \* REFS

F.A.S. RTE.	SECTION	COUNTY	TOTAL SHEETS	SHEET NO.
1380	*	PEORIA	16	7
STA. STA. 46+00 TO STA. STA. 49+00				
FED. ROAD DIST. NO. 4 ILLINOIS FED. AID PROJECT				
• D4 SCOUR MITIGATION 2008				

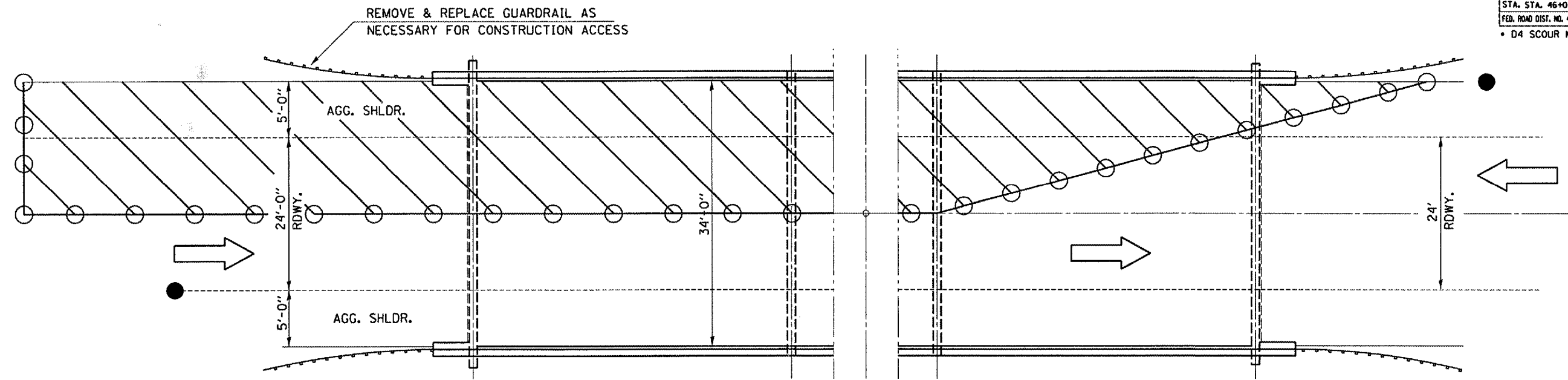

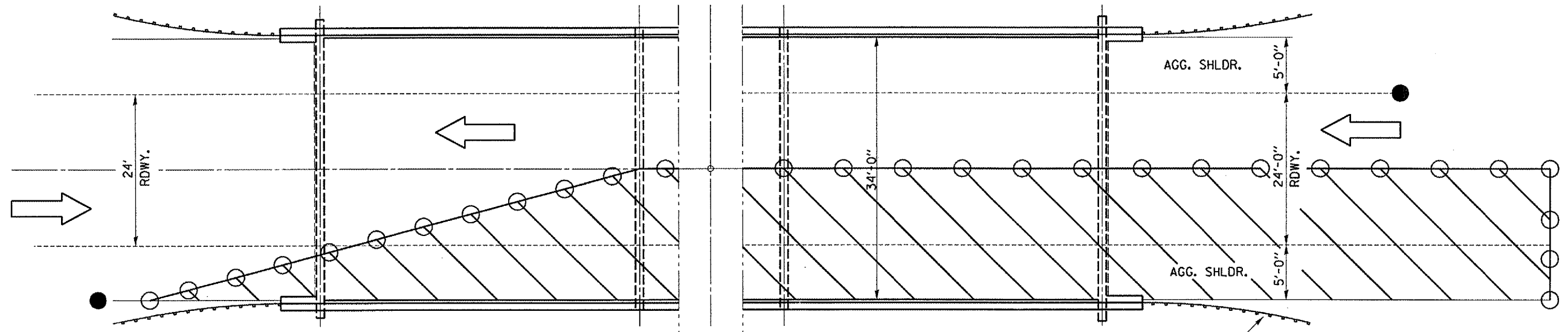

**STAGE I TRAFFIC**



**STAGE II TRAFFIC**

**SYMBOLS**

-  Work Area
-  Cone, Drum, or Barricade
-  Flagger w/Traffic Control Sign

**NOTES**

REFER TO HIGHWAY STANDARD 701201 FOR EXACT PLACEMENT OF TRAFFIC MANAGEMENT DEVICES AND OTHER CLARIFICATIONS AS CONSTRUCTION STAGING SYMBOLS AND DIMENSIONING WERE DUPLICATED OFF OF THIS STANDARD. STAGING ORDER TO BE DETERMINED BY THE RESIDENT ENGINEER AS PER WORK SCHEDULE REQUIREMENTS. CONTRACTOR SHALL PROVIDE ADDITIONAL TRAFFIC PROTECTION DEVICES AND INSTALLATION TO BE DETERMINED BY RESIDENT ENGINEER DURING TIME OF REMOVED GUARDRAIL FOR CONSTRUCTION ACCESS ENTERING AND EXITING OF ROADWAY. COST PAID FOR IN LSUM OF STANDARD 701201.

Structure (SN 072-0155) carrying IL 91 over Kickapoo Creek 1.5mi. S.of Dunlap

REVISIONS	
NAME	DATE

ILLINOIS DEPARTMENT OF TRANSPORTATION  
**TRAFFIC CONTROL AND STAGING**  
 SCALE: VERT.      DRAWN BY CEJ  
 DATE 05-25-2008      CHECKED BY

PLOT DATE   •••••  
 PLOT SCALE   •••••  
 PLOT NUMBER   •••••  
 REFERENCE   •••••

F.A.S. RTE.	SECTION	COUNTY	TOTAL SHEETS	SHEET NO.
1380	*	PEORIA	16	8
STA. 46+00		TO STA. 49+00		
FED. ROAD DIST. NO. 4 (ILLINOIS) FED. AID PROJECT				

D4 SCOUR MITIGATION 2008

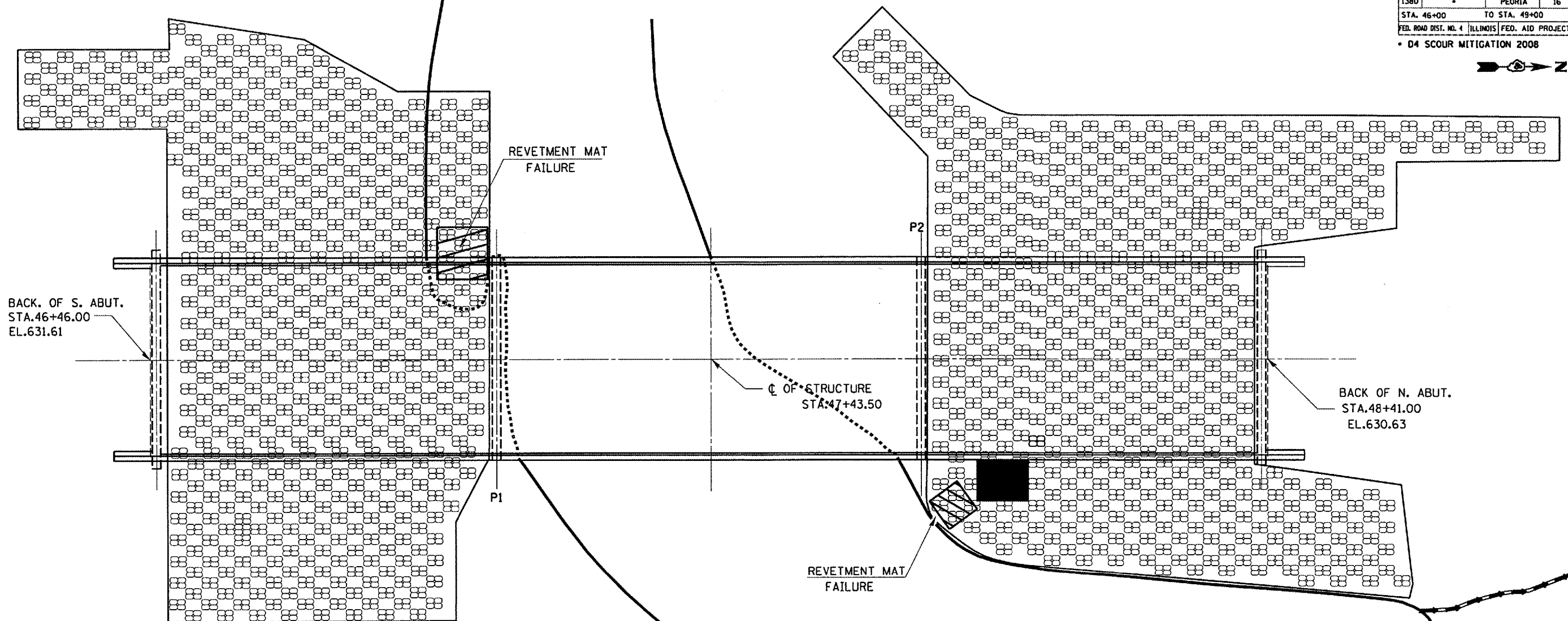

PLAN VIEW

AGGREGATE DITCH

CREEK EDGE

EXISTING REVETMENT MAT

RIPRAP PLACEMENT FOR EROSION CONTROL

REVETMENT MAT FAILURE

Structure (SN 072-0155) carrying IL 91 over Kickapoo Creek 1.5 mi. S. of Dunlap

REVISIONS	
NAME	DATE

ILLINOIS DEPARTMENT OF TRANSPORTATION

EXISTING REVETMENT MAT

SCALE: VERT. HORIZ. DATE 07-29-04

DRAWN BY MJH CHECKED BY

PLOT DATE \* DATE \*  
 PLOT SCALE \* SCALE \*  
 REFERENCE \* REF \*

Thomas Symonds



F.A.S. RTE.	SECTION	COUNTY	TOTAL SHEETS	SHEET NO.
1380		PEORIA	16	9
STA. 46+00		TO STA. 49+00		
FED. ROAD DIST. NO. 4 ILLINOIS FED. AID PROJECT				
D4 SCOUR MITIGATION 2008				

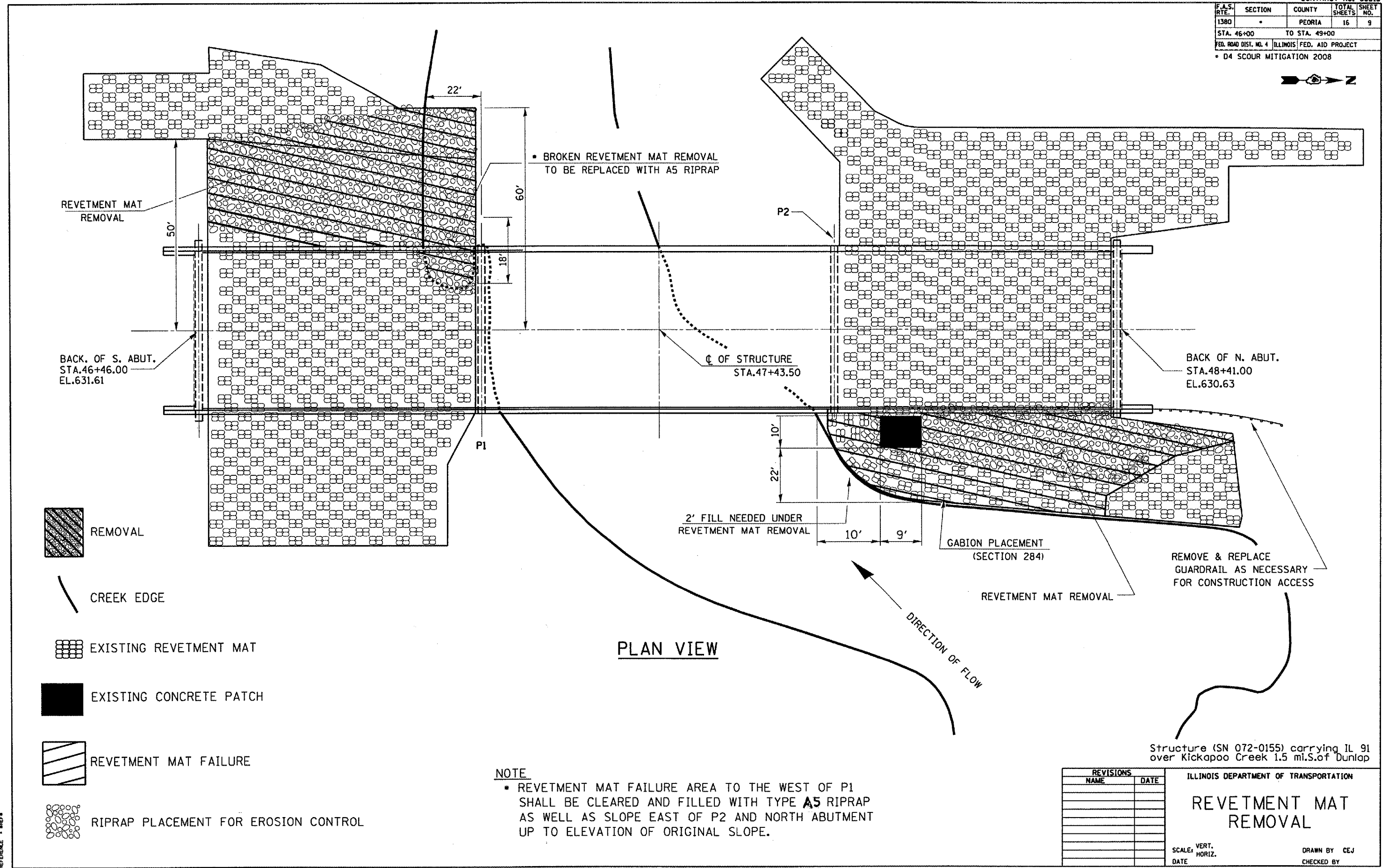

PLAN VIEW

**NOTE**  
 \* REVETMENT MAT FAILURE AREA TO THE WEST OF P1 SHALL BE CLEARED AND FILLED WITH TYPE **A5** RIPRAP AS WELL AS SLOPE EAST OF P2 AND NORTH ABUTMENT UP TO ELEVATION OF ORIGINAL SLOPE.

REVISIONS	
NAME	DATE

ILLINOIS DEPARTMENT OF TRANSPORTATION  
**REVETMENT MAT REMOVAL**  
 SCALE: VERT. \_\_\_\_\_  
 HORIZ. \_\_\_\_\_  
 DATE \_\_\_\_\_  
 DRAWN BY CEJ  
 CHECKED BY \_\_\_\_\_

PLOT DATE \* DATES  
 FILE NAME \* SHEET  
 PROJECT \* SCALE  
 REFERENCE \* SHEET

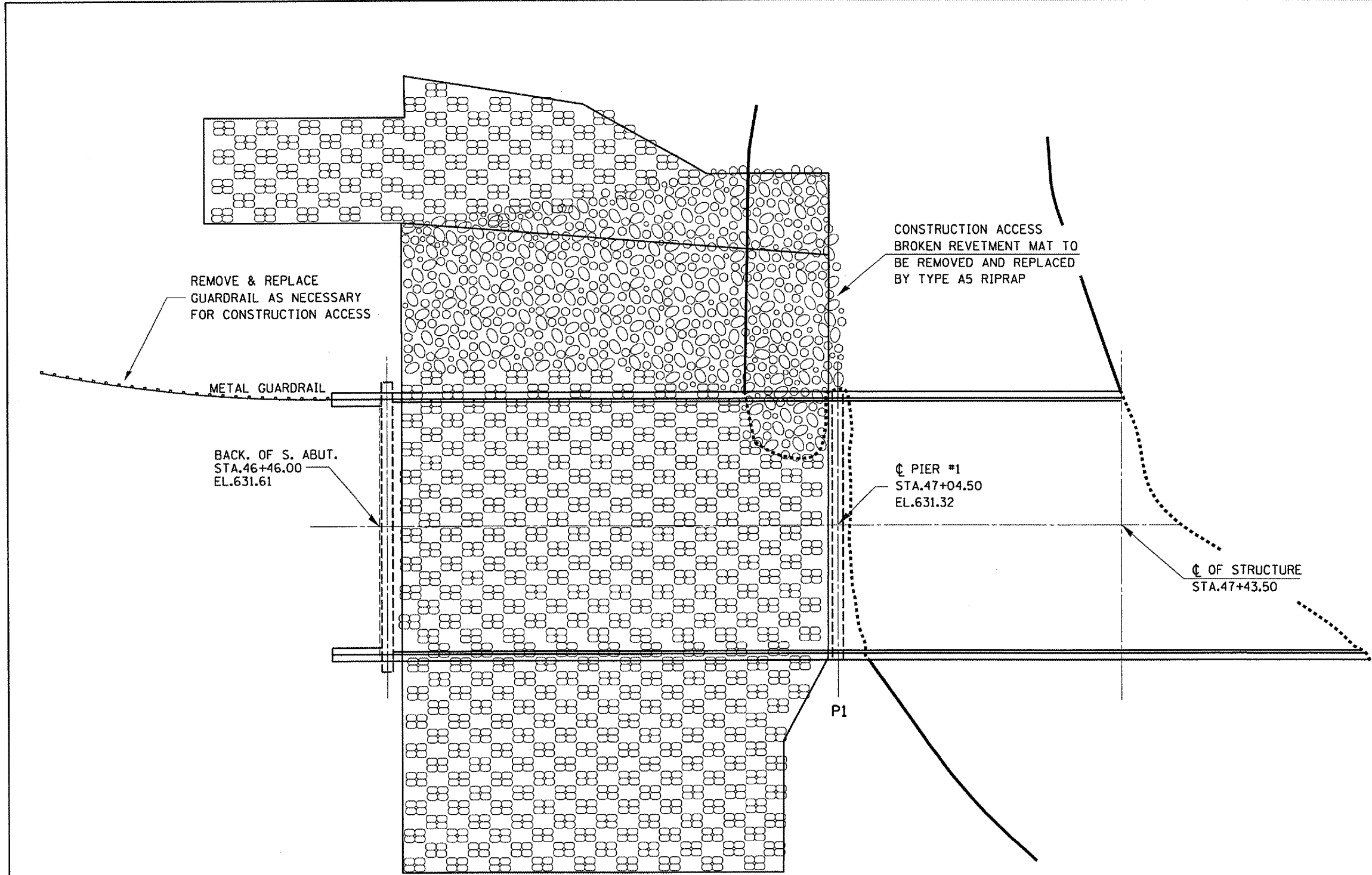

Structure (SN 072-0155) carrying IL 91 over Kickapoo Creek 1.5 mi.S.of Dunlap

CONTRACT NO. 68515				
F.A.S. RTE.	SECTION	COUNTY	TOTAL SHEETS	SHEET NO.
1380	*	PEORIA	16	10
STA. 46+00		TO STA. 49+00		
FED. ROAD DIST. NO. 4 ILLINOIS FED. AID PROJECT				
D4 SCOUR MITIGATION 2008				



**PARTIAL  
PLAN VIEW**

Structure (SN 072-0155) carrying IL 91  
over Kickapoo Creek 1.5 mi.S.of Dunlap

-  CREEK EDGE
-  EXISTING REVETMENT MAT
-  RIPRAP PLACEMENT FOR EROSION CONTROL

DATE \* NUMBER  
FILE NAME \* # OF SHEETS  
PLOT SCALE \* SCALES  
REFERENCE \* SHEETS

REVISIONS	
NAME	DATE

ILLINOIS DEPARTMENT OF TRANSPORTATION

## PROPOSED COUNTERMEASURE PLAN

SCALE: VERT. \_\_\_\_\_  
HORIZ. \_\_\_\_\_  
DATE \_\_\_\_\_

DRAWN BY CEJ  
CHECKED BY \_\_\_\_\_

F.A.S. RTE.	SECTION	COUNTY	TOTAL SHEETS	SHEET NO.
1380	•	PEORIA	16	11
STA. 46+00 TO STA. 49+00				
FED. ROAD DIST. NO. 4 ILLINOIS FED. AID PROJECT				
• D4 SCOUR MITIGATION 2008				



BACK OF N. ABUT.  
STA. 48+41.00  
Elev. 630.63

☐ OF STRUCTURE  
STA. 47+43.50

P2

PREVIOUS TEMPORARY EASEMENT  
ACCESS FROM FIELD ENTRANCE

EXISTING  
REVTMENT MAT

ROADWAY DRAINAGE  
DITCH INLET

NORMAL GROUNDLINE  
ADJACENT TO WATERWAY

GABIONS  
(SECTION 284)

BROKEN REVTMENT MAT TO  
BE REMOVED AND REPLACED  
BY TYPE A5 RIPRAP

PARTIAL  
PLAN VIEW

FLOW

DIRECTION OF FLOW

10'  
22'

10' 9'

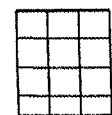

GABIONS



EXISTING REVTMENT MAT



EXISTING CONCRETE PATCH



RIPRAP PLACEMENT FOR EROSION CONTROL

PLOT DATE • DATE  
PLOT SCALE • SCALE  
REFERENCE • REF

Structure (SN 072-0155) carrying IL 91  
over Kickapoo Creek 1.5 mi.S.of Dunlap

REVISIONS	
NAME	DATE

ILLINOIS DEPARTMENT OF TRANSPORTATION

**PROPOSED  
COUNTERMEASURE  
PLAN**

SCALE: VERT.  
HORIZ.  
DATE 04-28-2006

DRAWN BY CEJ  
CHECKED BY

F.A.S. RTE.	SECTION	COUNTY	TOTAL SHEETS	SHEET NO.
1380		PEORIA	16	12
STA. 46+00		TO STA. 49+00		
FED. ROAD DIST. NO. 4 ILLINOIS FED. AID PROJECT				
D4 SCOUR MITIGATION 2008				

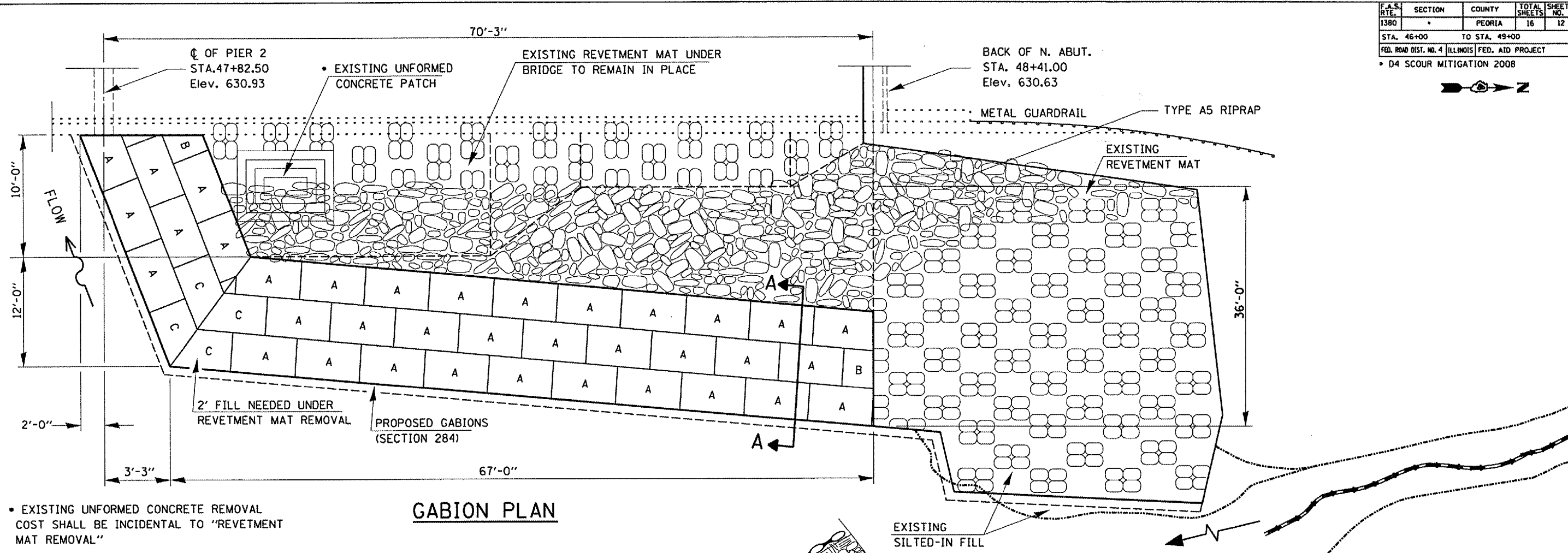

**GABION PLAN**

• EXISTING UNFORMED CONCRETE REMOVAL COST SHALL BE INCIDENTAL TO "REVETMENT MAT REMOVAL"

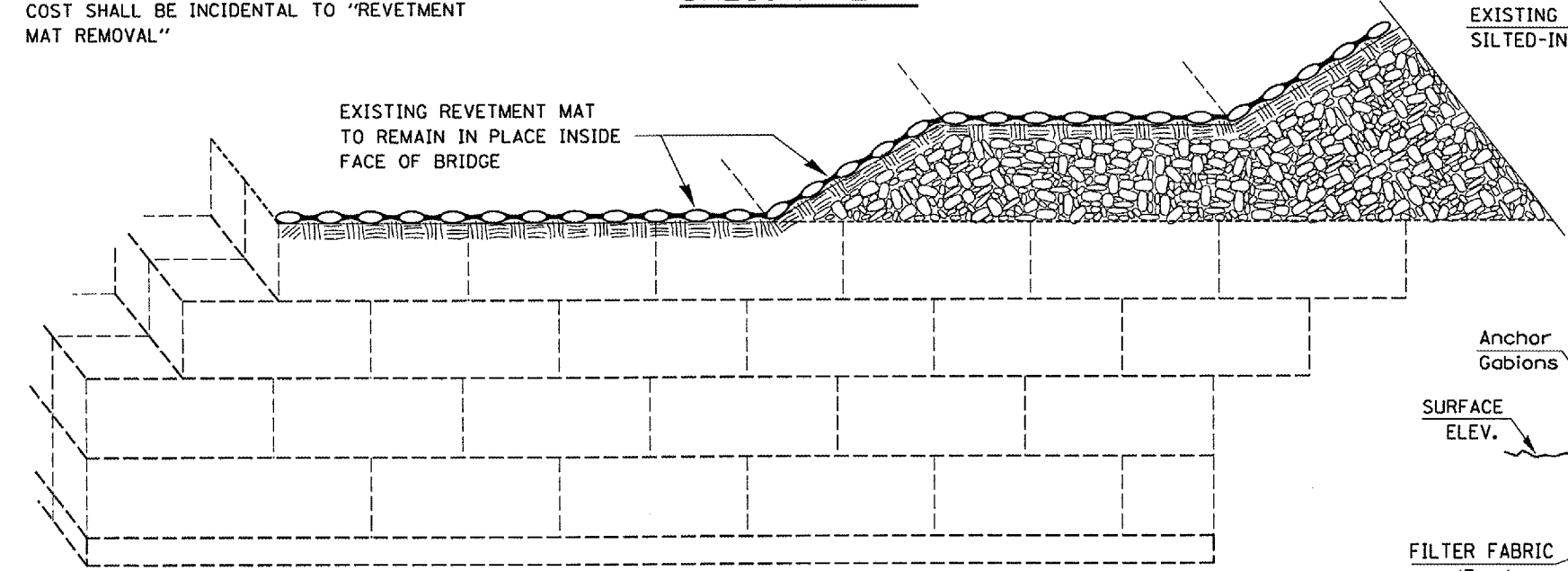

**PARTIAL ELEVATION**

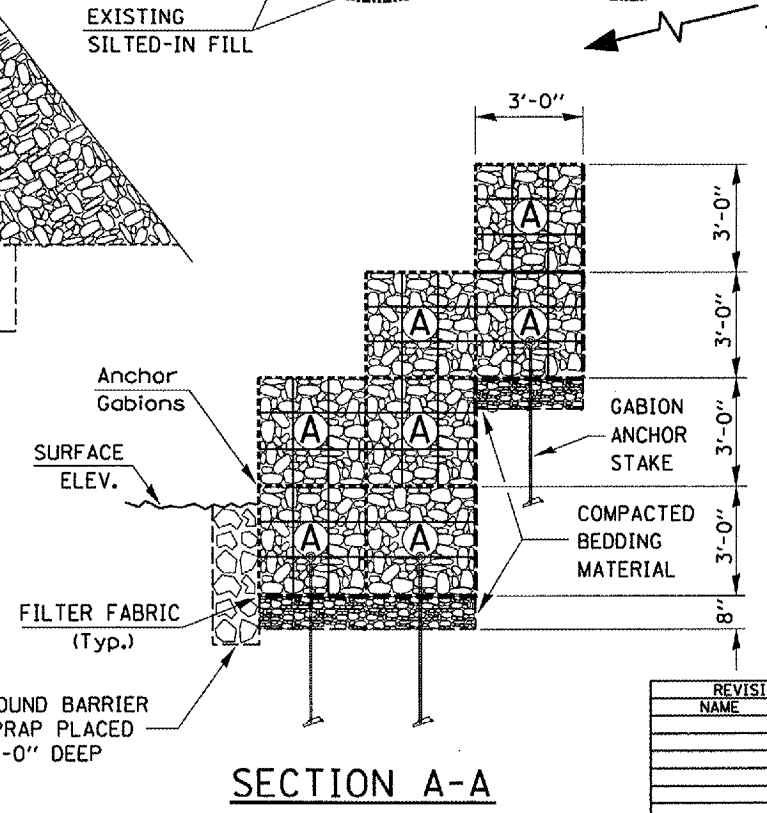

**SECTION A-A**

GABION LEGEND			
MARK	LENGTH	WIDTH	HEIGHT
A	6'	3'	3'
B	3'	3'	3'
C	VARIOUS	3'	3'

REVISIONS	
NAME	DATE

Structure (SN 072-0155) carrying IL 91 over Kickapoo Creek 1.5 mi.S.of Dunlap

ILLINOIS DEPARTMENT OF TRANSPORTATION  
**PROPOSED COUNTERMEASURE PLAN**

SCALE: VERT. HORIZ. DATE 03-18-2006

DRAWN BY CEJ  
CHECKED BY

PLOT DATE \* DWG. FILE NAME \* FILE# PLOT SCALE \* USLES REFERENCE \* WSP

F.A.S. RTE.	SECTION	COUNTY	TOTAL SHEETS	SHEET NO.
1380		PEORIA	16	13
STA. 46+00		TO STA. 49+00		
FED. ROAD DIST. NO. 4 ILLINOIS FED. AID PROJECT				
• D4 SCOUR MITIGATION 2008				

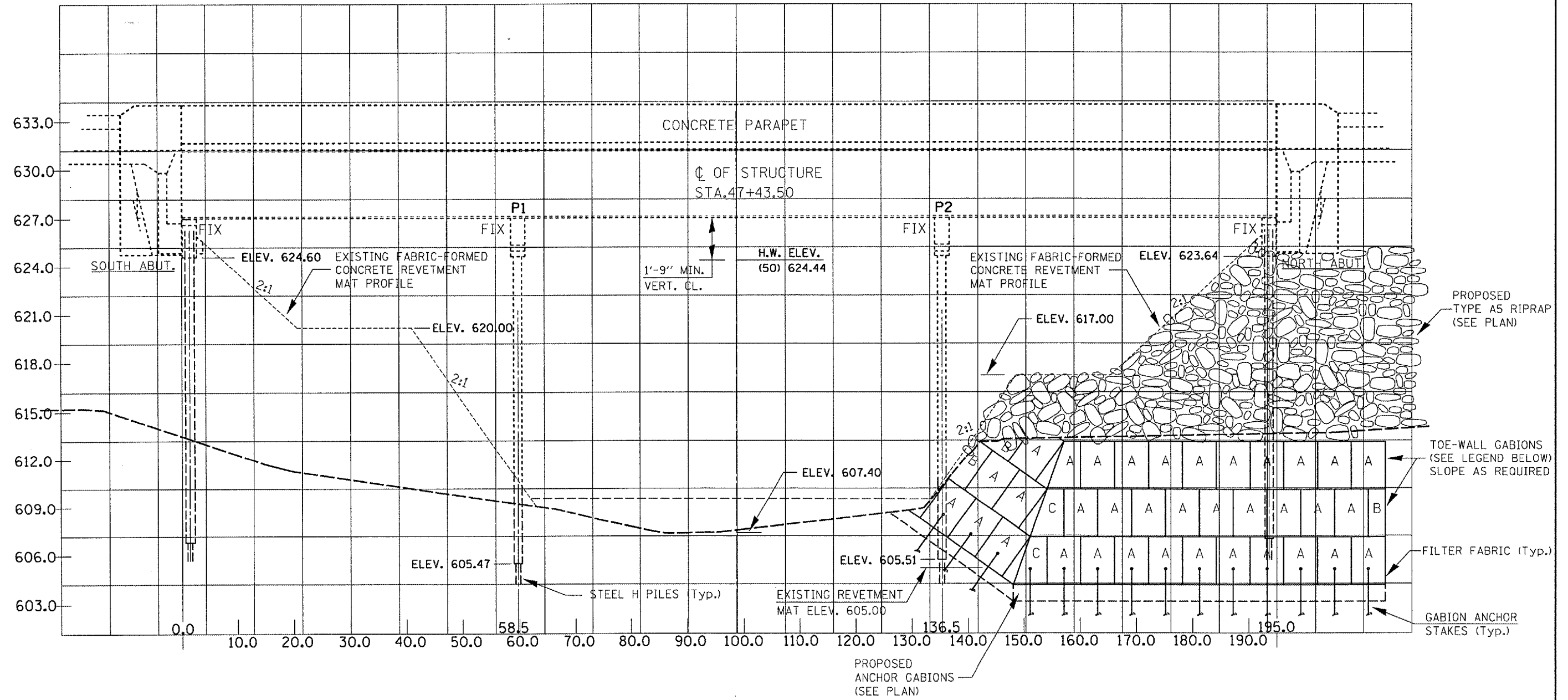

**ELEVATION**  
(Looking Downstream)

Structure (SN 072-0155) carrying IL 91 over Kickapoo Creek 1.5 mi. S. of Dunlap

GABION LEGEND			
MARK	LENGTH	WIDTH	HEIGHT
A	6'	3'	3'
B	3'	3'	3'
C	VARIOUS	3'	3'

REVISIONS	
NAME	DATE

ILLINOIS DEPARTMENT OF TRANSPORTATION  
**GABION TOE-WALL CROSS SECTION**  
SCALE: VERT. HORIZ.  
DATE 06-01-2006  
DRAWN BY CEJ  
CHECKED BY

PLOT DATE: 06/01/06  
FILE NAME: 060106.DWG  
PLOT SCALE: 1/8\"/>

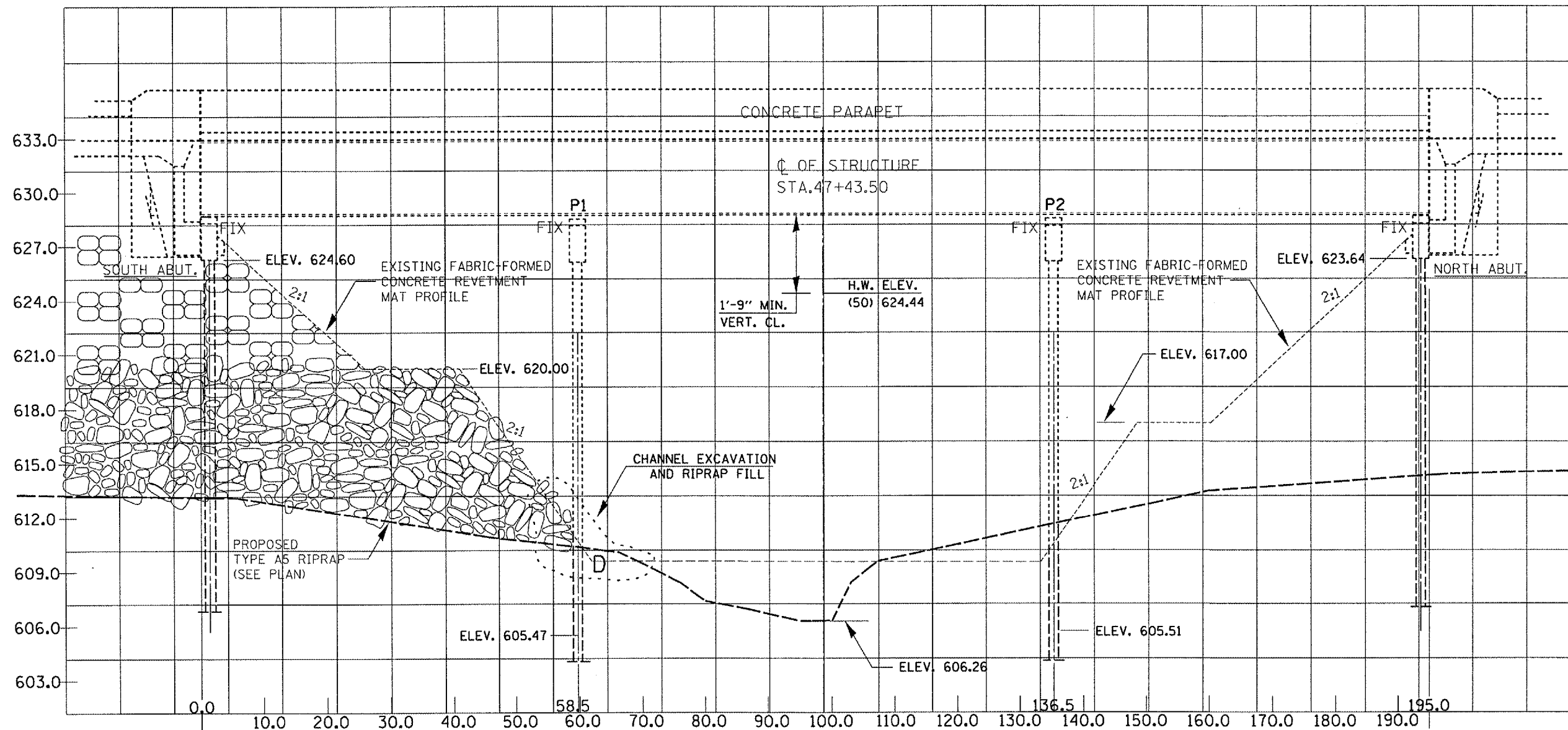

**ELEVATION**  
(Looking Downstream)

Structure (SN 072-0155) carrying IL 91  
over Kickapoo Creek 1.5 mi. S. of Dunlap

CHANNEL EXCAVATION			
MARK	LENGTH	WIDTH	HEIGHT
D	6'	3'	3'

REVISIONS	
NAME	DATE

ILLINOIS DEPARTMENT OF TRANSPORTATION  
**WEST BRIDGE FACE  
CROSS SECTION**

SCALE: VERT.  
HORIZ.  
DATE 06-07-2006

DRAWN BY CEJ  
CHECKED BY



F.A.S. RTE.	SECTION	COUNTY	TOTAL SHEETS	SHEET NO.
1380	*	PEORIA	16	15
STA. 46+00		TO STA. 49+00		
FED. ROAD DIST. NO. 4 ILLINOIS FED. AID PROJECT				
* D4 SCOUR MITIGATION 2008				

### SUGGESTED INSTALLATION SEQUENCE

(SEE ALSO SECTION 284 OF THE STANDARD SPECIFICATIONS)

- INDIVIDUALLY ASSEMBLE THE EMPTY GABION BASKET UNITS.
- POSITION THE INITIAL LINE OF EMPTY GABION BASKET UNITS ON THE PREPARED SURFACE IN A DIRECTION PERPENDICULAR TO STREAM FLOW. SECURE ADJOINING BASKETS AND PARTIALLY FILL TO PROVIDE ANCHORAGE AGAINST DEFORMATION AND DISPLACEMENT DURING FILLING OPERATIONS.
- POSITION AND SECURE THE REMAINING EMPTY GABION BASKET UNITS ON THE PREPARED SURFACE AS SHOWN ON THE PLANS.
- PLACE THE BASKETS IN TENSION AND STRETCH TO REMOVE ANY KINKS FROM THE FABRIC. STRETCH THE EMPTY GABION BASKET UNITS IN A MANNER THAT WILL PREVENT UNRAVELING.
- FILL THE BASKET UNITS IN STAGES TO PREVENT LOCALIZED DEFORMATION. INTERNAL CONNECTING WIRES SHALL BE INSTALLED BETWEEN STONE LAYERS TO CONNECT THE FRONT FACE OF THE BASKET UNIT TO THE BACK FACE. AT NO TIME SHALL ANY CELL BE FILLED TO A DEPTH EXCEEDING 12 INCHES MORE THAN THE ADJOINING CELL. THE MAXIMUM HEIGHT FROM WHICH THE STONE MAY BE DROPPED INTO THE BASKET SHALL BE 3 FT.
- TIGHTLY STRETCH THE LID OVER THE STONE FILL USING A LID CLOSING TOOL APPROVED BY THE MANUFACTURER. USING CROWBARS OR OTHER SINGLE POINT LEVERAGE BARS FOR LID CLOSING SHALL BE PROHIBITED. TIGHTLY SECURE THE LID TO THE FILLED BASKET ALONG ALL EDGES, ENDS AND INTERNAL CELL DIAPHRAMS.
- IN LIEU OF FILLING BASKETS IN PLACE, THE BASKETS MAY BE PREFILLED ON A LEVEL SURFACE AS INDICATED IN STEPS 5 AND 6. THE BASKETS CAN THEN BE LIFTED AND PLACED ON THE PREPARED SURFACE USING A MANUFACTURER'S APPROVED LIFTING TECHNIQUE. CARE SHALL BE TAKEN NOT TO ABRASE THE ZINC OR VINYL COATING OR PERMANENTLY DISTORT THE SHAPE OF THE BASKET IN TRANSPORTATION. ANY DAMAGE TO THE BASKETS SHALL BE REPAIRED AT THE CONTRACTOR'S EXPENSE TO THE SATISFACTION OF THE ENGINEER. BASKETS SHALL BE PLACED TIGHTLY AGAINST AND SECURED TO BASKETS ALREADY IN PLACE.
- WHERE A COMPLETE GABION UNIT CANNOT BE INSTALLED AS SHOWN ON THE PLANS BECAUSE OF SPACE LIMITATIONS, THE BASKET UNIT SHALL BE CUT, FOLDED AND WIRED TOGETHER TO SUIT EXISTING SITE CONDITIONS.

FABRIC OPENING NOMINAL DIMENSIONS  
3 1/4" x 4 1/2"

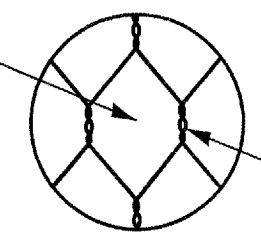

HEXAGONAL MESH FABRIC WITH AT LEAST THREE HALF TWISTS

- NOTES:
- GABION BASKETS SHALL BE CONSTRUCTED OF A GALVANIZED, ALUMINIZED, OR PVC-COATED GALVANIZED OR ALUMINIZED STEEL WIRE.
  - STEEL WIRE SHALL CONFORM TO SECTION 1006.35 OF THE STANDARD SPECIFICATIONS

### GABION FABRIC DETAIL

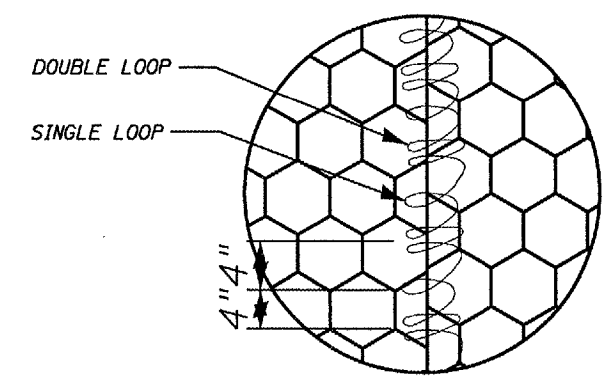

### GABION BASKET NOTES:

- BASKETS SHALL BE OF SINGLE UNIT CONSTRUCTION. THE BASE, LID, ENDS AND SIDES SHALL BE EITHER WOVEN INTO A SINGLE UNIT OR ONE EDGE OF THESE MEMBERS CONNECTED TO THE BASE SECTION OF THE BASKETS. FOR PROPER ASSEMBLAGE, SEE LACING DETAIL.
- DIAPHRAMS SHALL EQUALLY DIVIDE BASKETS WHERE THE LENGTH OF THE BASKET EXCEEDS 1/2 IT'S HORIZONTAL LEGNTH.
- GABION BASKET ASSEMBLAGE, INSTALLATION, FILLING AND LID-CLOSING SHALL BE IN ACCORDANCE WITH SECTION 284 OF THE STANDARD SPECIFICATIONS.

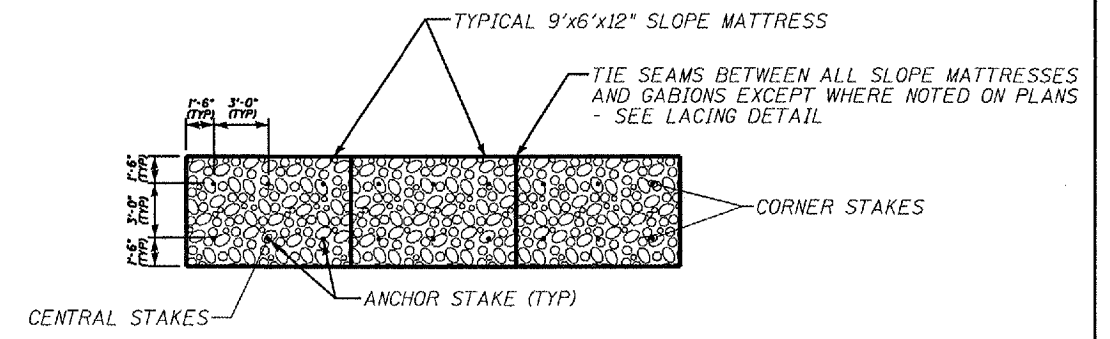

### NOTES:

- ANCHOR STAKES SHALL BE PROVIDED IN ACCORDANCE WITH SECTION 284 OF THE STANDARD SPECIFICATIONS.
- ANCHOR STAKES ARE TO BE PLACED ON THREE-FOOT CENTERS, WITH AN ARRANGEMENT AS SHOWN ABOVE. FOR ALL SLOPE MATTRESSES LAID ON A SLOPE OF 2:1 OR GREATER.
- ANCHOR STAKES FOR SLOPE MATTRESSES LAID ON SLOPE LESS THAN 2:1 AND GREATER THAN 10% SHALL OMIT THE CENTRAL STAKES SHOWN ABOVE - 4 STAKES PER 6'x9' MATTRESS.
- ALL SLOPE MATTRESSES LAID ON SLOPES LESS THAN 10% SHALL NOT HAVE ANCHOR STAKES.

### TYPICAL ANCHOR STAKE LAYOUT DETAIL

GABION LEGEND			
MARK	LENGTH	WIDTH	HEIGHT
A	6'	6'	3'
B	3'	6'	3'
C	VARIOUS	6'	3'

Structure (SN 072-0155) carrying IL 91 over Kickapoo Creek 1.5 mi.S.of Dunlap

ILLINOIS DEPARTMENT OF TRANSPORTATION

### GABION DETAILS

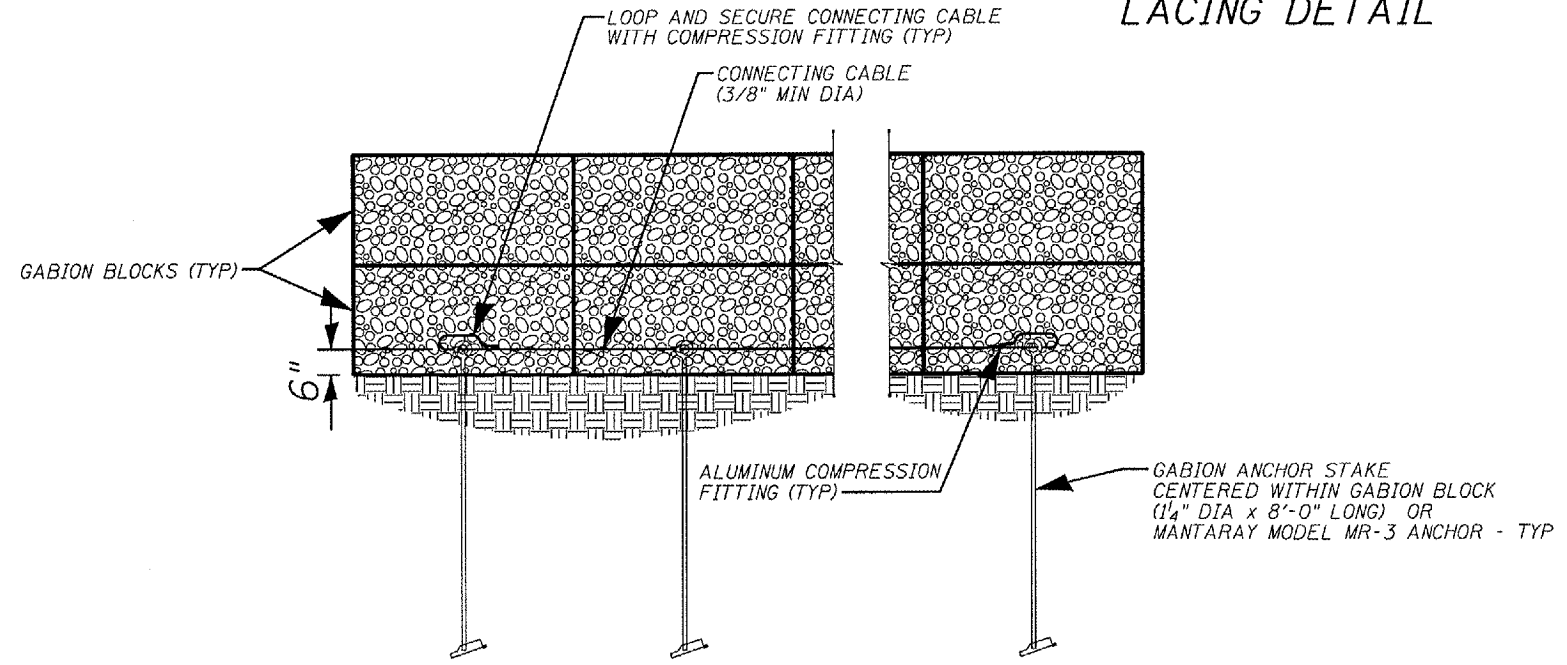

### GABION ANCHOR STAKE SECURING DETAIL

DATE  
FILE NAME  
PLOT SCALE  
REFERENCE

ROUTE NO.	SECTION	COUNTY	TOTAL SHEETS	SHEET NO.
F.A.S. 1380	*	PEORIA	16	16
FED. ROAD DIST. NO. 4		ILLINOIS	FED. AID PROJECT	

\* D4 SCOUR MITIGATION 2008

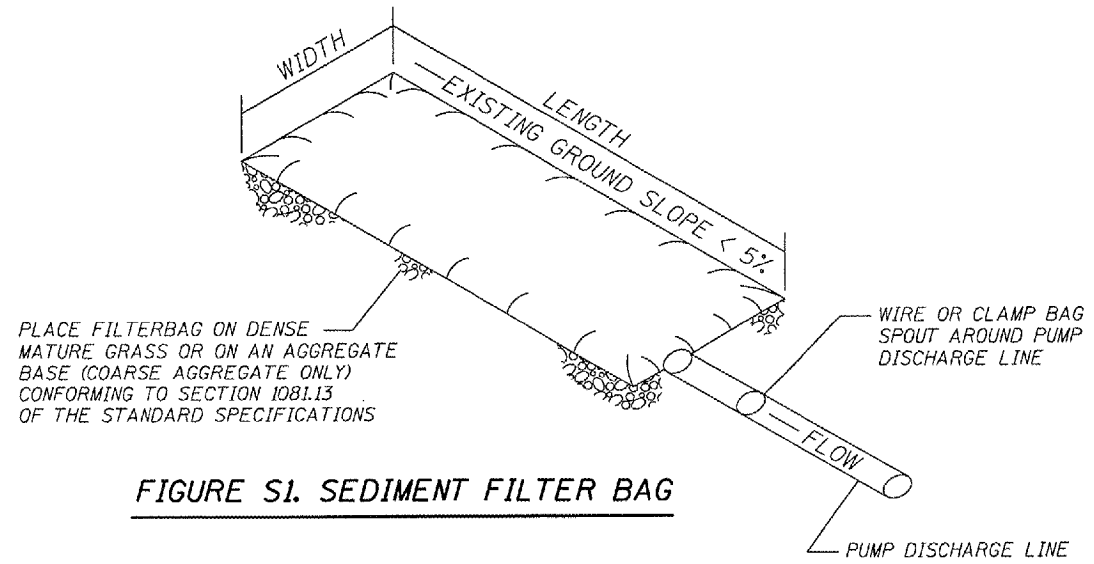

**FIGURE S1. SEDIMENT FILTER BAG**

ENSURE THAT RUNOFF FROM THE BAG LOCATION IS PREVENTED FROM CAUSING EROSION BY GRASS, STONE, OR GEOTEXTILE LINING OF DISCHARGE CHANNEL.

REMOVE SILT WHEN BAG IS HALF FULL OR MORE OFTEN IF RECOMMENDED BY THE MANUFACTURER. DISPOSE OF SILT BY TRANSPORTING THE FILLED BAG TO DISPOSAL AREA. SLIT THE BAG, BLEND SILT INTO EXISTING TOPOGRAPHY, SEED AND MULCH

MAINTAIN EXTRA FILTER BAGS ON SITE. REPLACE DAMAGED BAGS PROMPTLY

TYPICAL FLOW RATE: 10 GPM x W x L

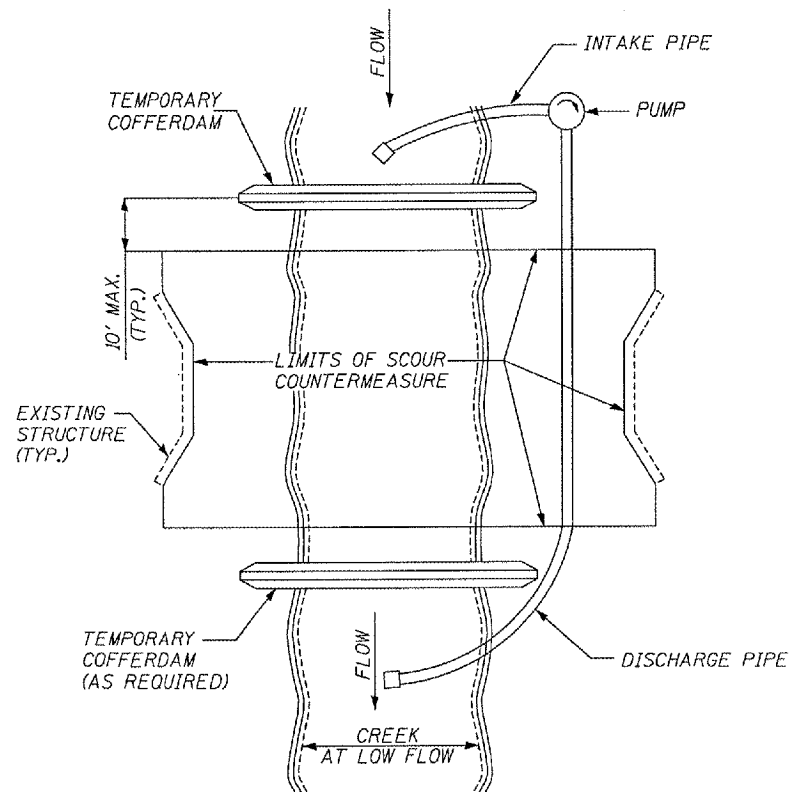

**FIGURE D1. TEMPORARY COFFERDAM WITH PUMP BYPASS**

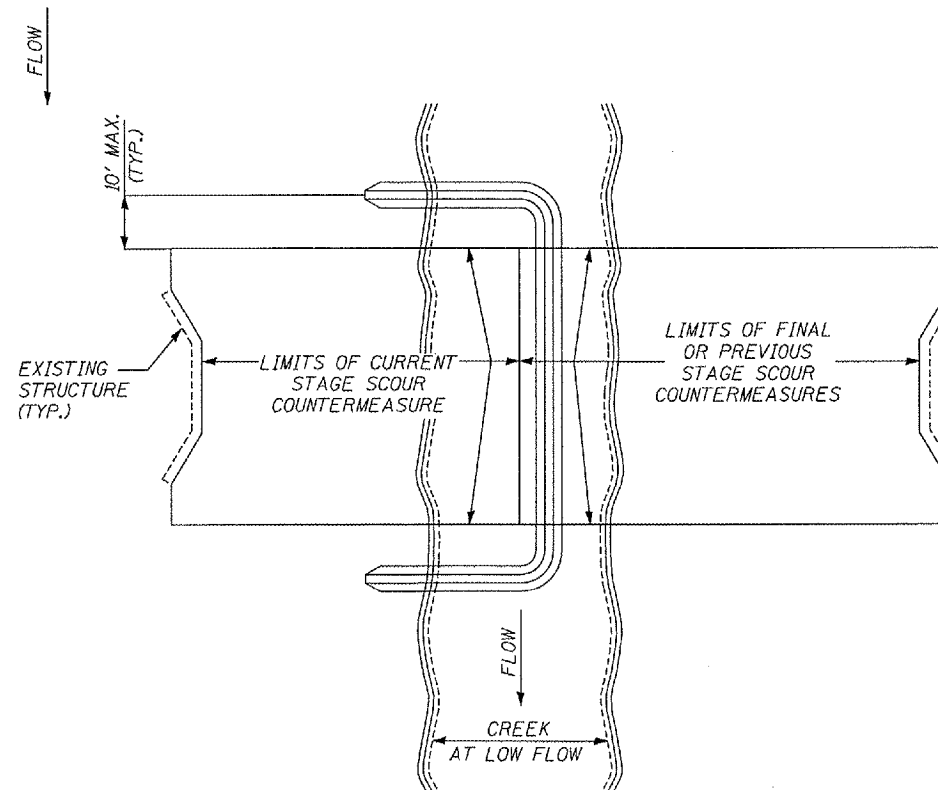

**FIGURE D2. STAGED IN-STREAM COFFERDAM DIVISION**

NOTE: DEWATERING SYSTEM DETAILS SHALL BE USED IN CONJUNCTION WITH THE PROJECT SPECIAL PROVISIONS.

ILLINOIS DEPARTMENT OF TRANSPORTATION

DEWATERING SYSTEM DETAILS  
S.N. 072-0155  
IL 91 OVER KICKAPOO CRK.



CONTRACT NO. 68515				
F.A.S. RTE.	SECTION	COUNTY	TOTAL SHEETS	SHEET NO.
1380		PEORIA	16	16A
STA. 46+00		TO STA. 49+00		
FED. ROAD DIST. NO. 4 ILLINOIS FED. AID PROJECT				
• D4 SCOUR MITIGATION 2008				

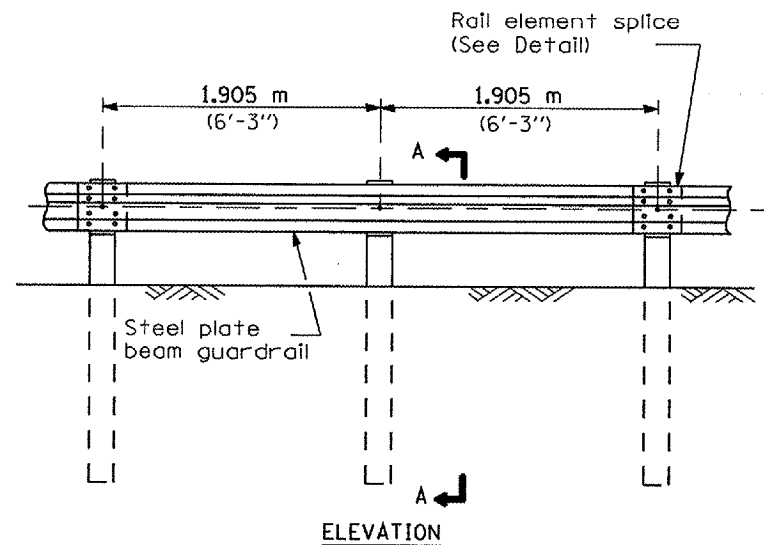

**TYPE A**

1.905 m (6'-3") Typical post spacing

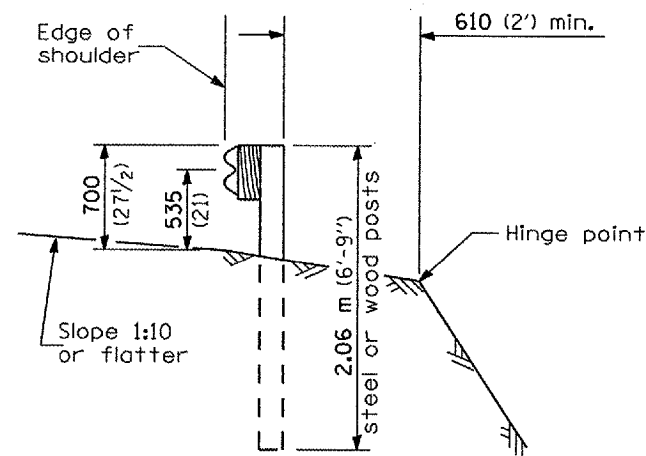

**SECTION A-A**

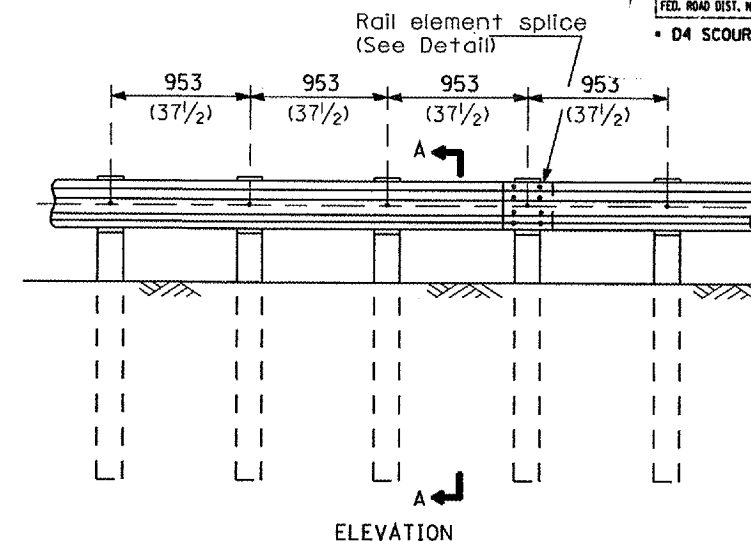

**TYPE B**

953 (37 1/2) Closed post spacing

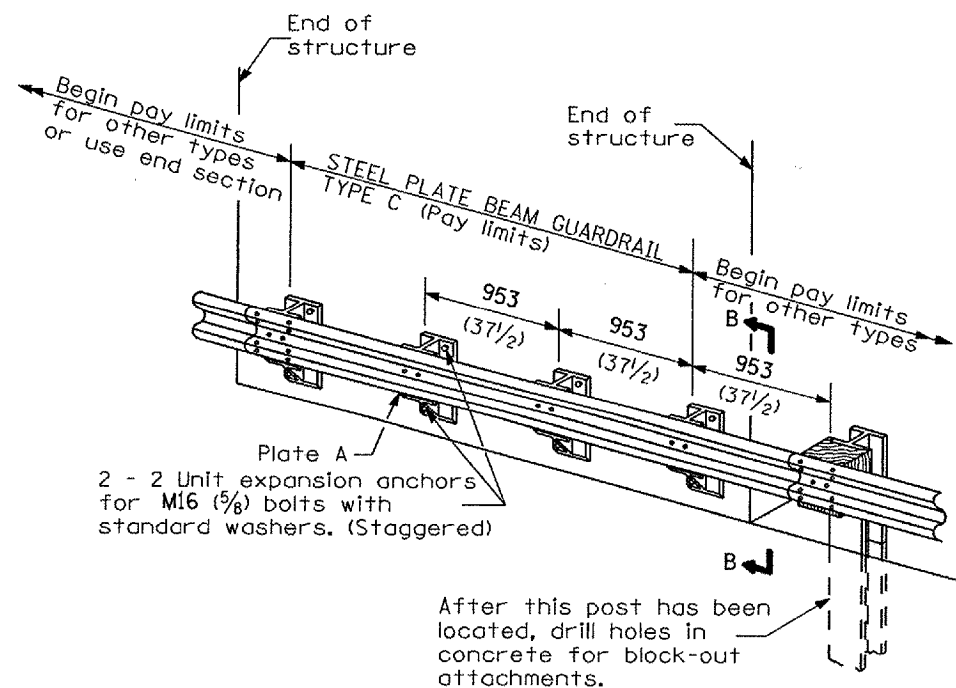

**TYPE C**

953 (37 1/2) Block-out spacing

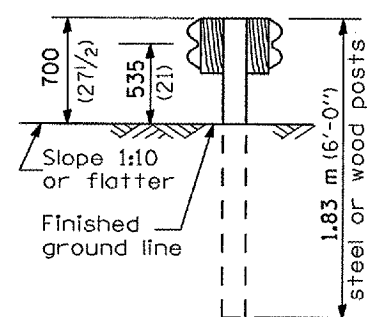

**SECTION C-C**

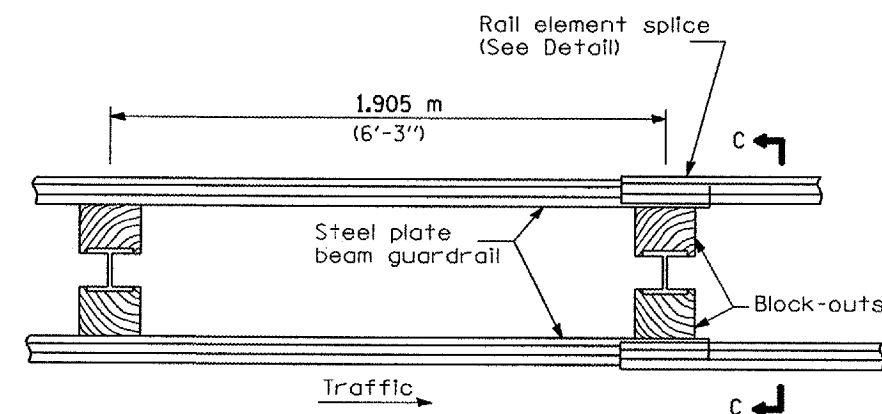

**PLAN**

**TYPE D**

Double steel plate beam guardrail  
1.905 m (6'-3") typical post spacing

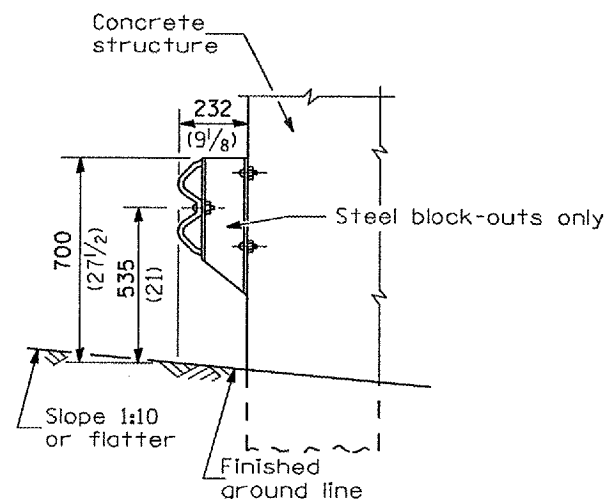

**SECTION B-B**

**GENERAL NOTES**

All slope ratios are expressed as units of vertical displacement to units of horizontal displacement (V:H).

All dimensions are in millimeters (inches) unless otherwise shown.

The existing steel posts may be drilled to match the bolt pattern shown herein for the wood block-out, or a new steel post shall be provided.

This detail is applicable to the guardrail system used prior to January 1, 2007. For details on the Midwest Guardrail System, see Standard 630001.

**REMOVE AND REERECT  
STEEL PLATE BEAM GUARDRAIL**

(Sheet 1 of 4)

**DETAIL**

CONTRACT NO. 68515				
F.A.S. RITE.	SECTION	COUNTY	TOTAL SHEETS	SHEET NO.
1380		PEORIA	16	16
STA. 46+00		TO STA. 49+00		
FED. ROAD DIST. NO. 4 ILLINOIS FED. AID PROJECT				
D4 SCOUR MITIGATION 2008				

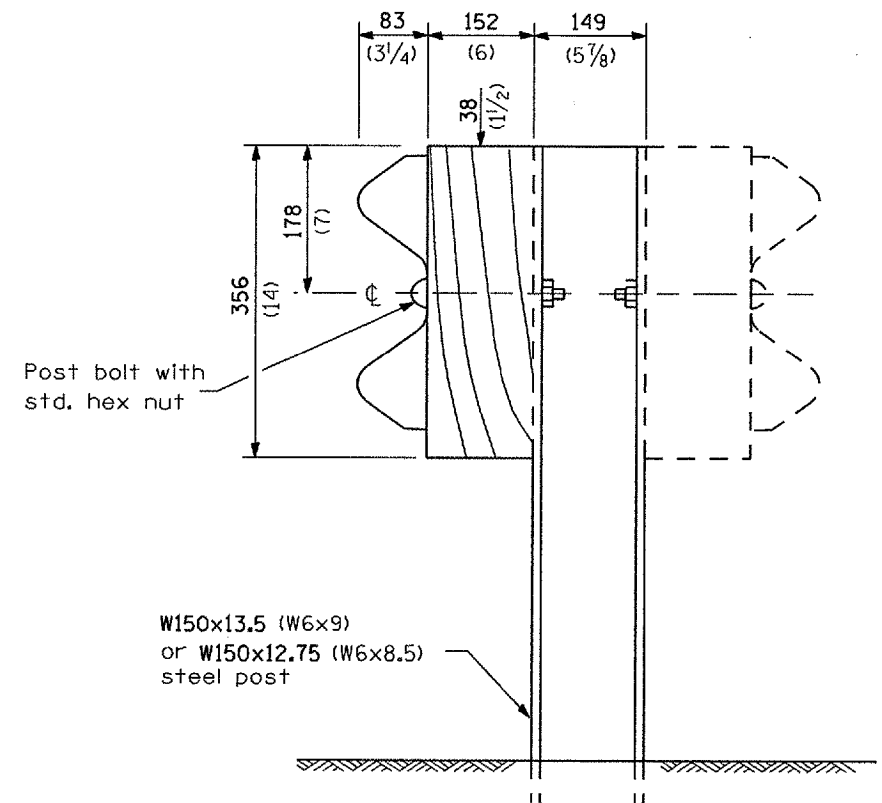

W150x13.5 (W6x9)  
or W150x12.75 (W6x8.5)  
steel post

**STEEL POST CONSTRUCTION**

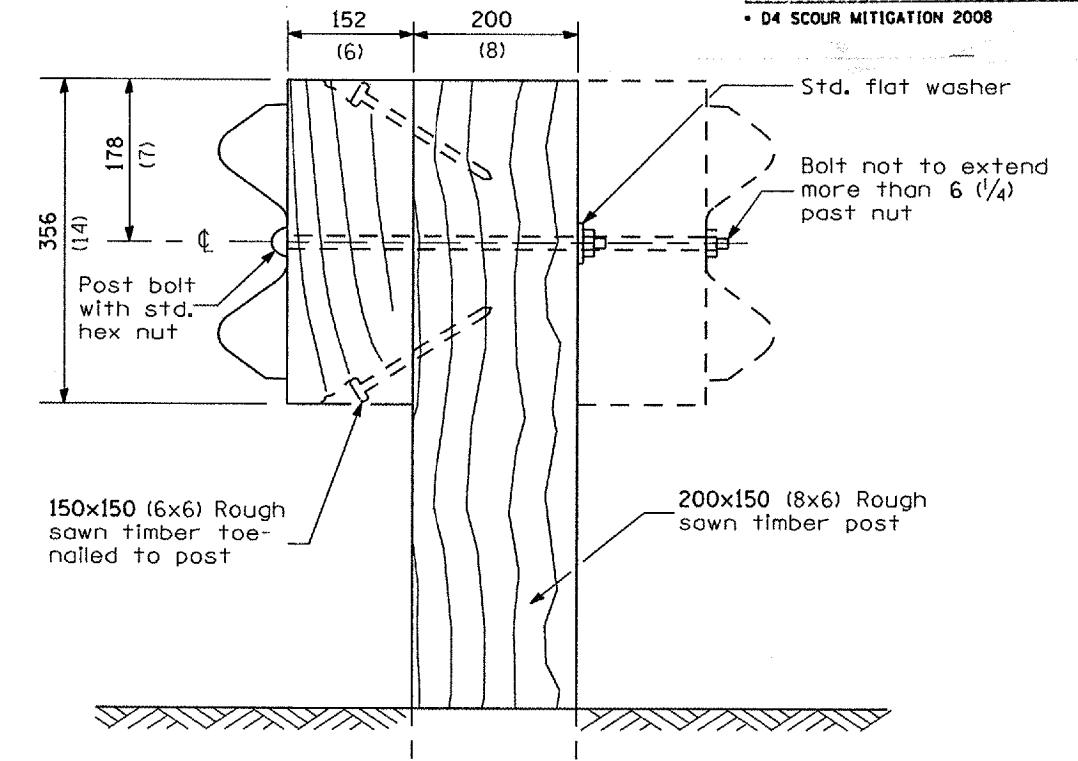

**WOOD POST CONSTRUCTION**

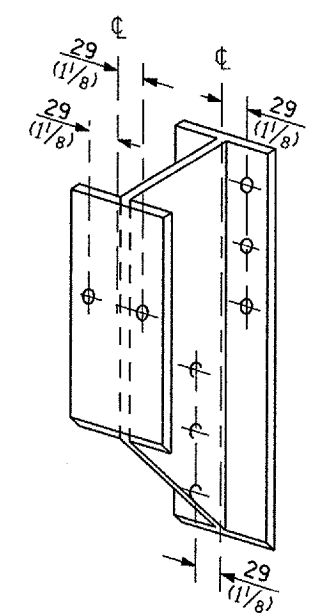

**STEEL BLOCK-OUT DETAIL**

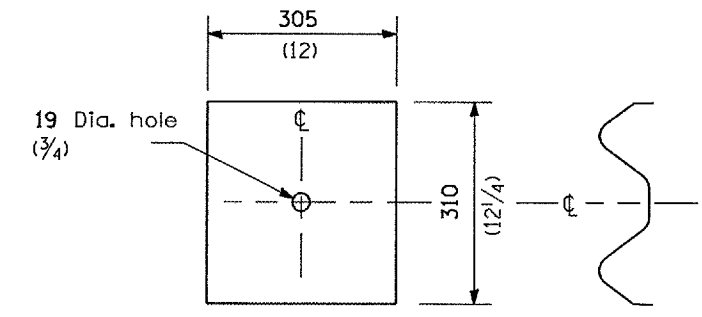

NOTE

Plate A shall be placed between rail element and block-out at non-splice mounting points only when steel block-outs are used.

**PLATE A**

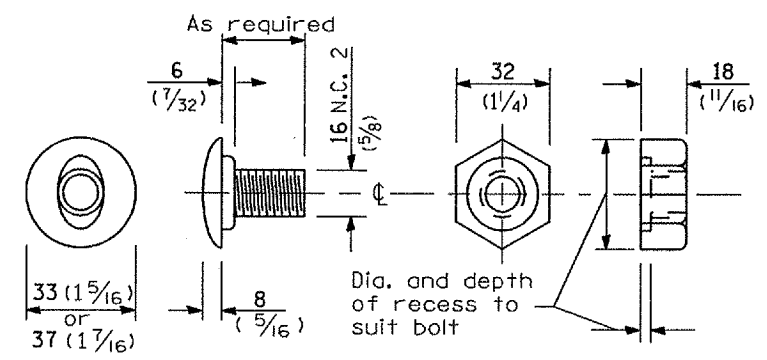

**POST OR SPLICE BOLT & NUT**

**REMOVE AND REERECT  
STEEL PLATE BEAM GUARDRAIL**  
(Sheet 2 of 4)

**DETAIL**

CONTRACT NO. 68515				
F.A.S. RITE.	SECTION	COUNTY	TOTAL SHEETS	SHEET NO.
1380		PEORIA	16	16C
STA. 46+00		TO STA. 49+00		
FED. ROAD DIST. NO. 4 ILLINOIS FED. AID PROJECT				
• D4 SCOUR MITIGATION 2008				

Place standard end shoe between splice plate and rail element

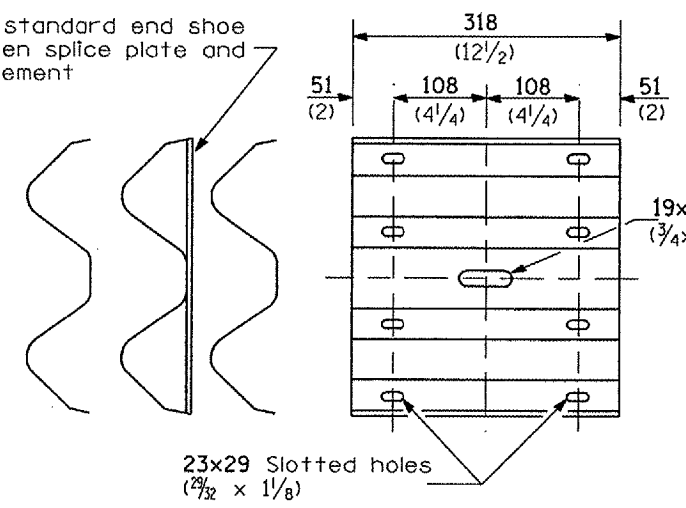

**SPLICE PLATE**

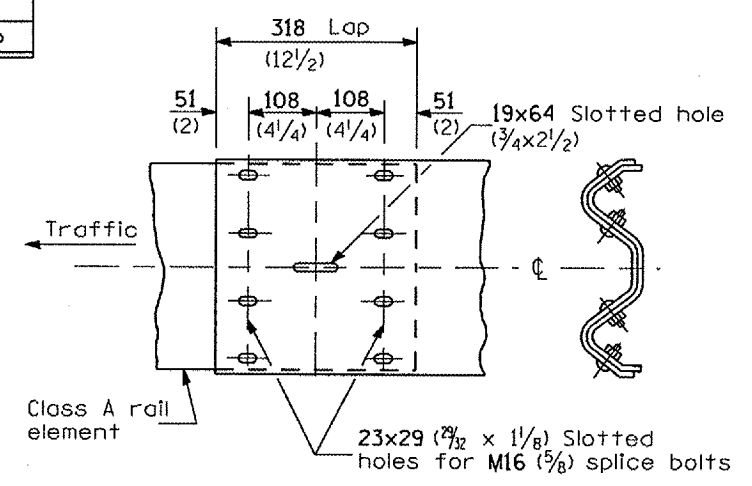

**RAIL ELEMENT SPLICE**

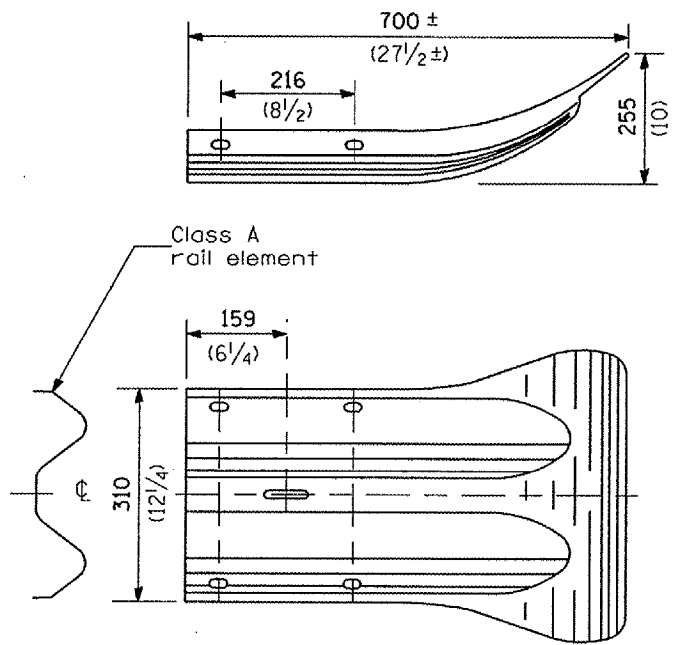

**END SECTION**

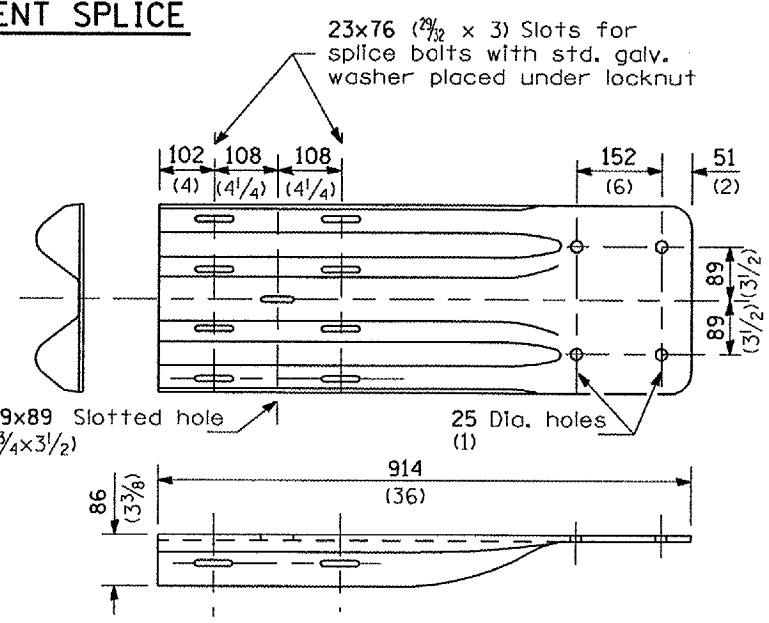

**NOTE**

When end shoe is attached to a bridge parapet which has an expansion joint, the bolts shall be provided with a locknut or double nut and shall be tightened only to a point that will allow guardrail movement.

The standard end shoe shall be attached to the concrete with pre-drilled or self-drilling anchor bolts. The anchor cone shall be set flush with the surface of the concrete.

Externally threaded studs protruding from the surface of the concrete will not be permitted.

**END SHOE**

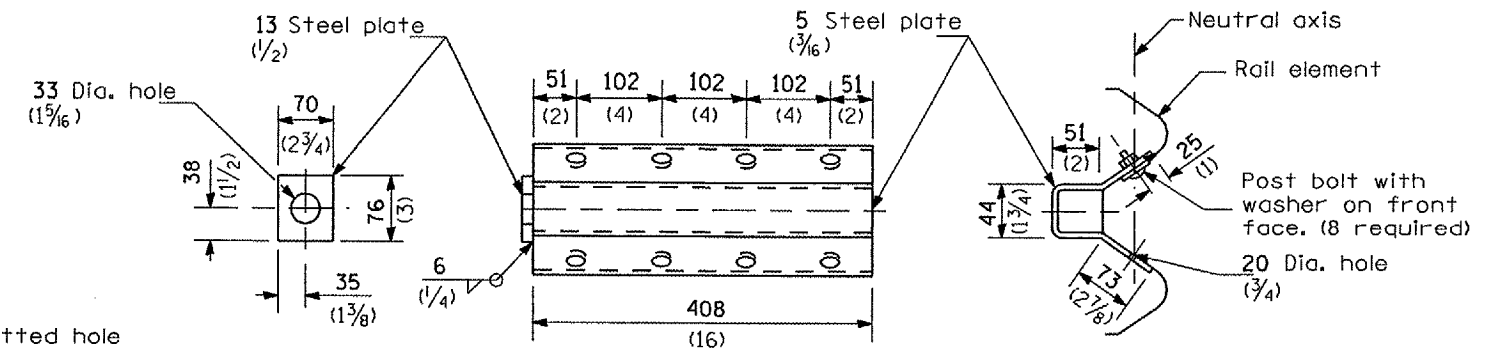

**NOTE**

Anchor plate T shall be used to attach cable assembly to guardrail when required on traffic barrier terminals.

**ANCHOR PLATE T DETAILS**

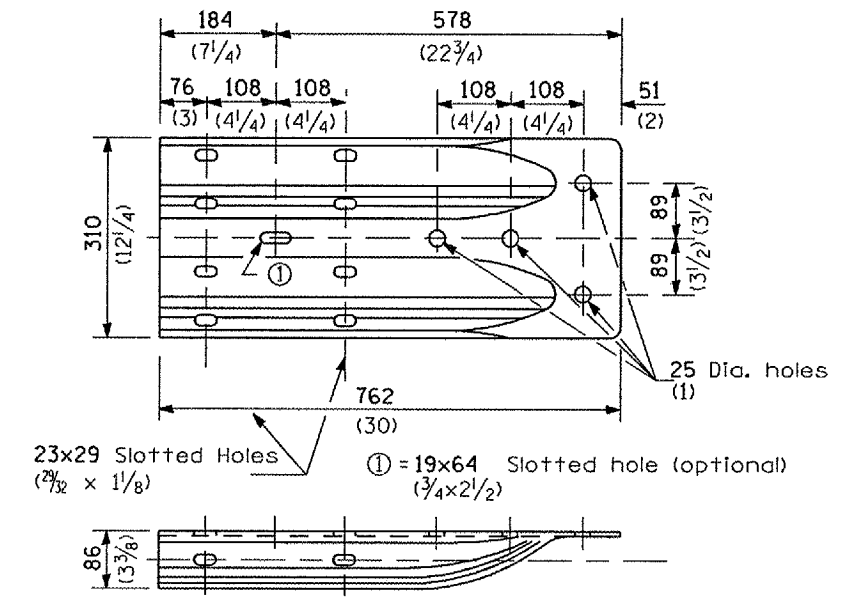

**ALTERNATE END SHOE**

**REMOVE AND REERECT STEEL PLATE BEAM GUARDRAIL**  
(Sheet 3 of 4)  
**DETAIL**

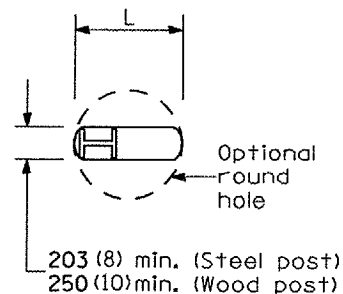

**PLAN**

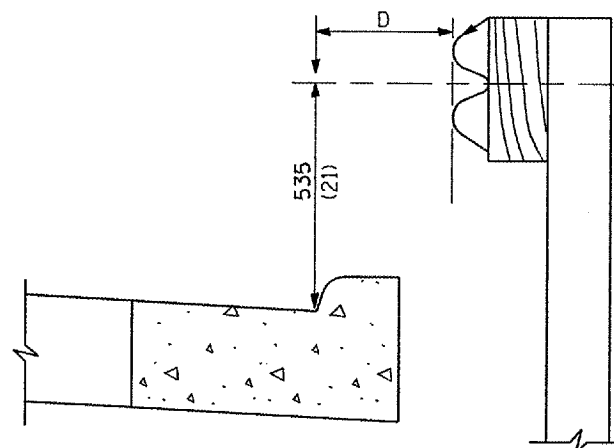

Note:  
If it is necessary for D to be more than 300 (12) and less than 3.0 m (10'-0") type M-5 (M-2) curb and gutter (Std. 606001) shall be used in front of and in advance of the guardrail.

**GUARDRAIL PLACED BEHIND CURB**

(D = 0 desirable to 300 (12) maximum)

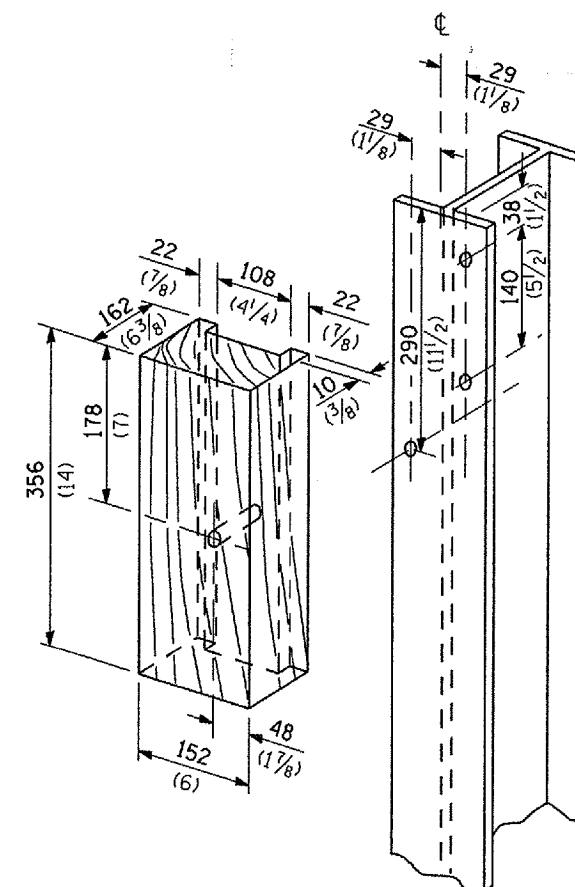

**WOOD BLOCK-OUT AND STEEL POST DETAILS**

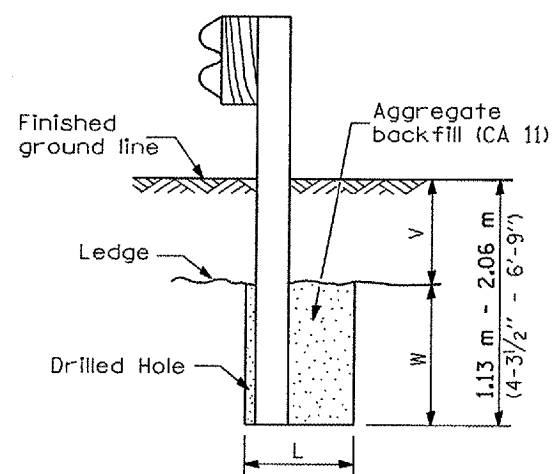

Note:  
Ledge line is top of rock ledge or hard slag fill.

**ELEVATION**

**FOOTING FOR POST WHEN IMPERVIOUS MATERIAL IS ENCOUNTERED**

V	W	L	
		Steel Post	Wood Post
0 - 460 (0 - 18)	610 (24)	530 (21)	580 (23)
>460 - 825 (>18 - 41.5)	305 (12)	203 (8)	250 (10)
>825 - 1.13 m (>41.5 - 53.5)	305 - 0 (12 - 0)	203 (8)	250 (10)

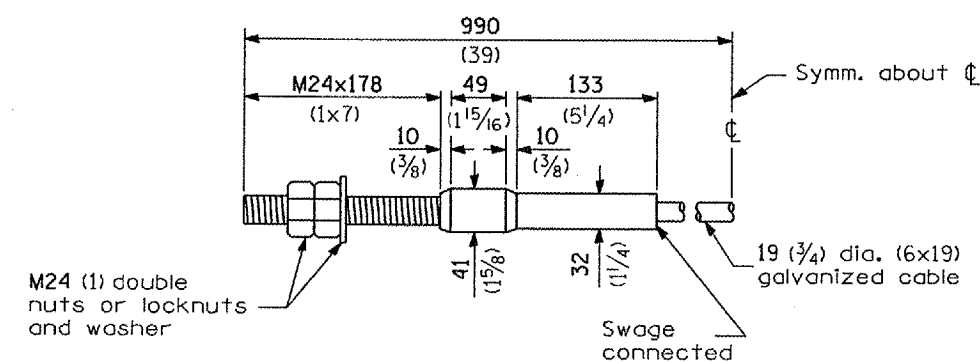

**CABLE ASSEMBLY**

(18,100 kg (40,000 lbs.) min. breaking strength)  
Tighten to taut tension.

**REMOVE AND REERECT STEEL PLATE BEAM GUARDRAIL**

(Sheet 4 of 4)

**DETAIL**