

TYPE A

1.905 m (6'-3") Typical post spacing

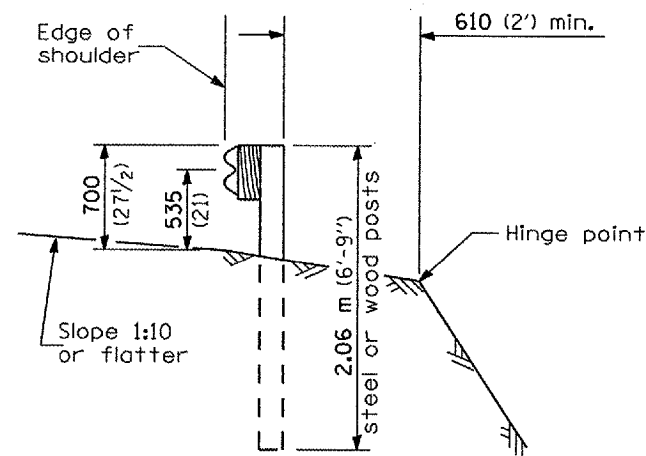

SECTION A-A

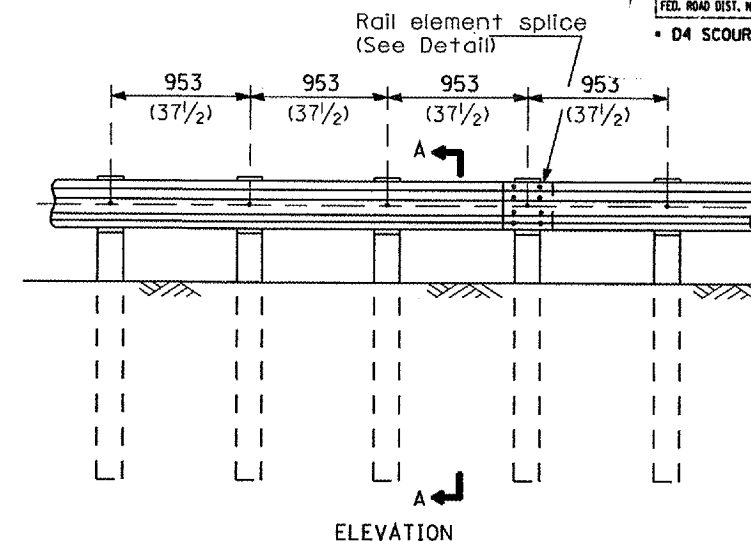

TYPE B

953 (37 1/2) Closed post spacing

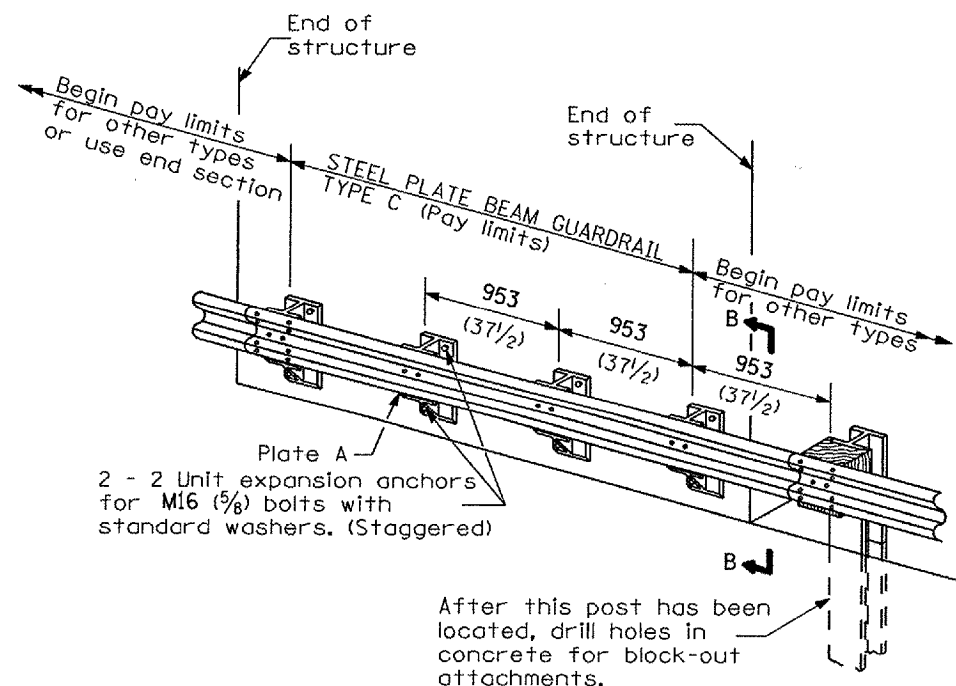

TYPE C

953 (37 1/2) Block-out spacing

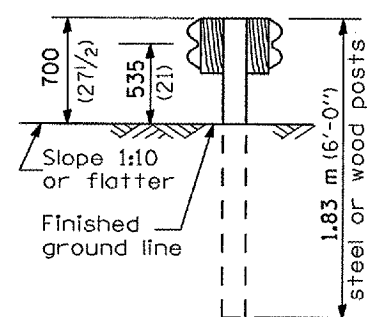

SECTION C-C

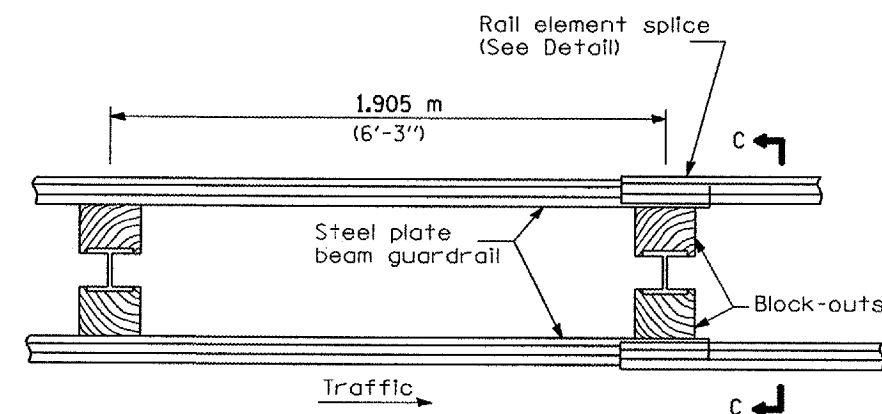

PLAN

TYPE D

Double steel plate beam guardrail
1.905 m (6'-3") typical post spacing

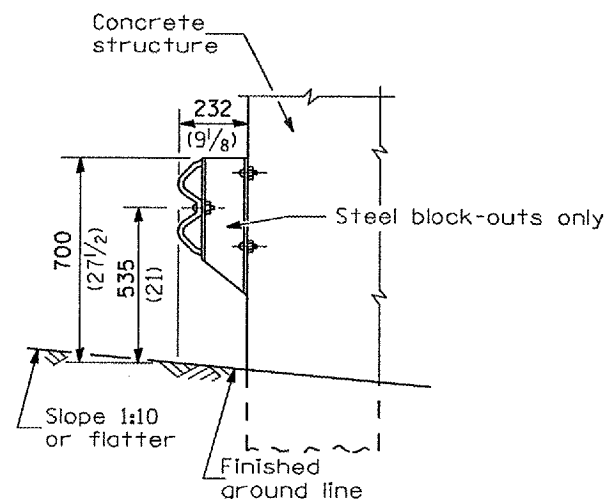

SECTION B-B

GENERAL NOTES

All slope ratios are expressed as units of vertical displacement to units of horizontal displacement (V:H).

All dimensions are in millimeters (inches) unless otherwise shown.

The existing steel posts may be drilled to match the bolt pattern shown herein for the wood block-out, or a new steel post shall be provided.

This detail is applicable to the guardrail system used prior to January 1, 2007. For details on the Midwest Guardrail System, see Standard 630001.

**REMOVE AND REERECT
STEEL PLATE BEAM GUARDRAIL**

(Sheet 1 of 4)

DETAIL