

F.A.P. RTE.	SECTION	COUNTY	TOTAL SHEETS	SHEET NO.
642	11T	CARROLL	79	59
STA.		TO STA.		
FED. ROAD DIST. NO.		ILLINOIS FED. AID PROJECT		

# HOT-MIX ASPHALT APPROACHES & MAILBOX TURNOUTS

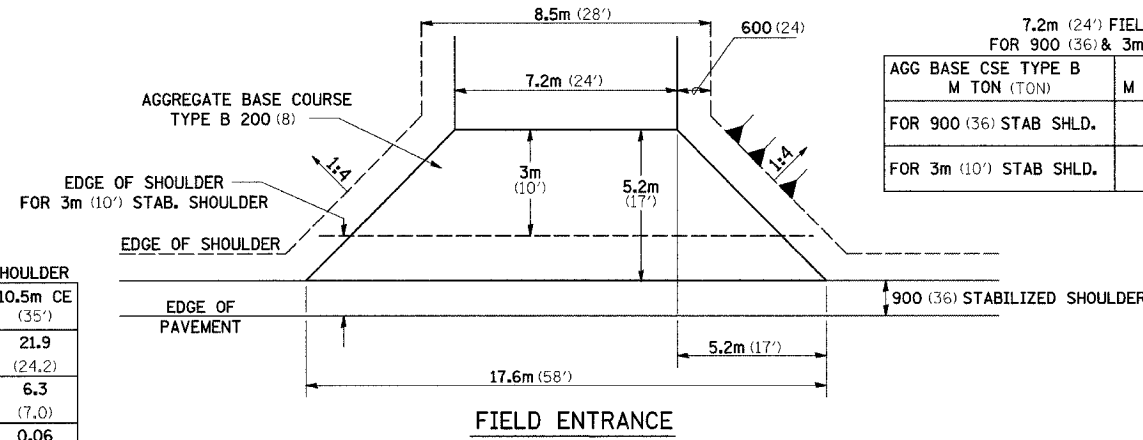

AGG BASE CSE TYPE B M TON (TON)	APRON M TON (TON)	PER METER (FOOT) ADD. RUN
FOR 900 (36) STAB SHLD.	31.3 (35.3)	3.5 (1.2)
FOR 3m (10') STAB SHLD.	14.9 (17.2)	3.5 (1.2)

**PE & CE FOR 3m (10') STAB. SHOULDER**

	3.6m PE (12')	10.5m CE (35')
AGG BASE CSE (TON)	11.4 (12.6)	21.9 (24.2)
INC HMA SURF (TON)	3.1 (3.4)	6.3 (7.0)
PRIME (TON)	0.04 (0.04)	0.06 (0.07)

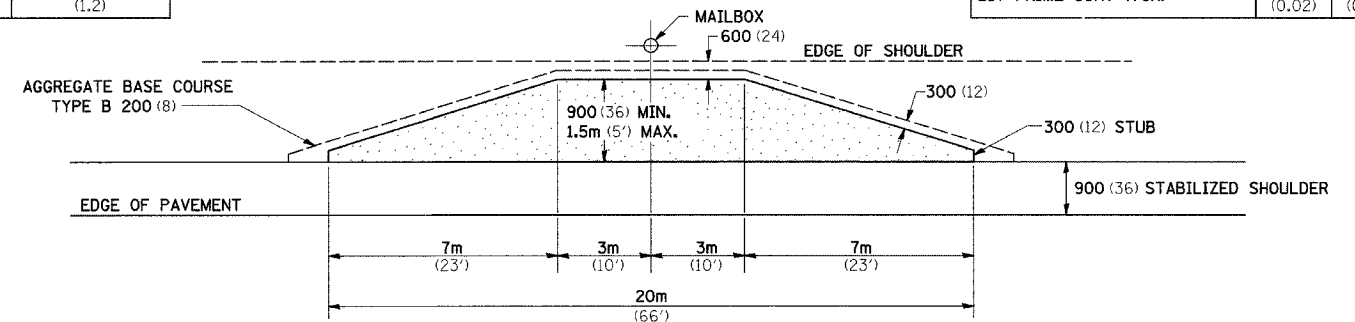

**10.5m (35') COMMERCIAL ENTRANCE FOR 900 (36) STAB. SHOULDER**

	900 (36)	1.5m (5')	PER METER ENTR (FOOT)
AGG BASE CSE T-B (TON)	47.4 (52.2)	48.7 (53.7)	5.7 (1.9)
INC HMA SURF 50 (2) (TON)	13.4 (14.8)	14.0 (15.4)	1.6 (0.55)
BIT PRIME COAT (TON)	0.14 (0.15)	0.15 (0.16)	0.018 (0.006)

**NOTE**

- ALL ENTRANCES TO BE CONSTRUCTED WITH AN 8" AGGREGATE BASE COURSE, TYPE B AND WITH A 2" INCIDENTAL HOT-MIX ASPHALT SURFACING, UNLESS OTHERWISE NOTED.
- TURNOUTS ARE TO BE CONSTRUCTED ON THE APPROACH SIDE OF ALL PE & CE REGARDLESS IF A MAILBOX IS PRESENT.
- ALL PE & CE ARE TO BE SURFACED TO RIGHT OF WAY LINE. AREA BEHIND RIGHT OF WAY SHALL MATCH EXISTING SURFACE.
- FE ARE TO BE AGGREGATE TO RIGHT OF WAY OR TOUCH DOWN WHICH EVER IS GREATER.
- QUANTITIES SHOWN ARE FOR NEW CONSTRUCTION.
- ALL DIMENSIONS ARE IN MILLIMETERS (INCHES) UNLESS OTHERWISE NOTED.

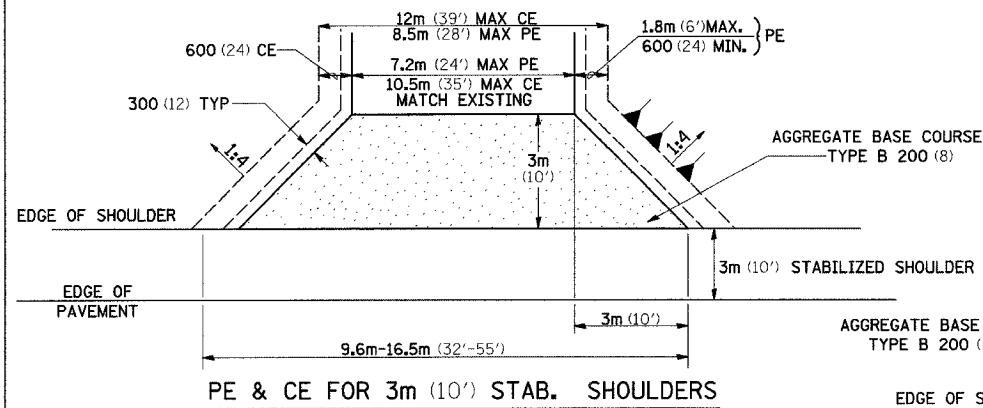

**3.6m (12') PRIVATE ENTRANCE FOR 900 (36) STAB. SHOULDER**

	900 (36)	1.5m (5')	PER METER ENTR (FOOT)
AGG BASE CSE (TON)	29.4 (32.4)	30.8 (33.9)	0.64 (0.7)
INC HMA SURF 50 (2) (TON)	7.8 (8.6)	8.4 (9.3)	0.17 (0.19)
BIT PRIME COAT (TON)	0.08 (0.09)	0.09 (0.10)	0.006 (0.002)

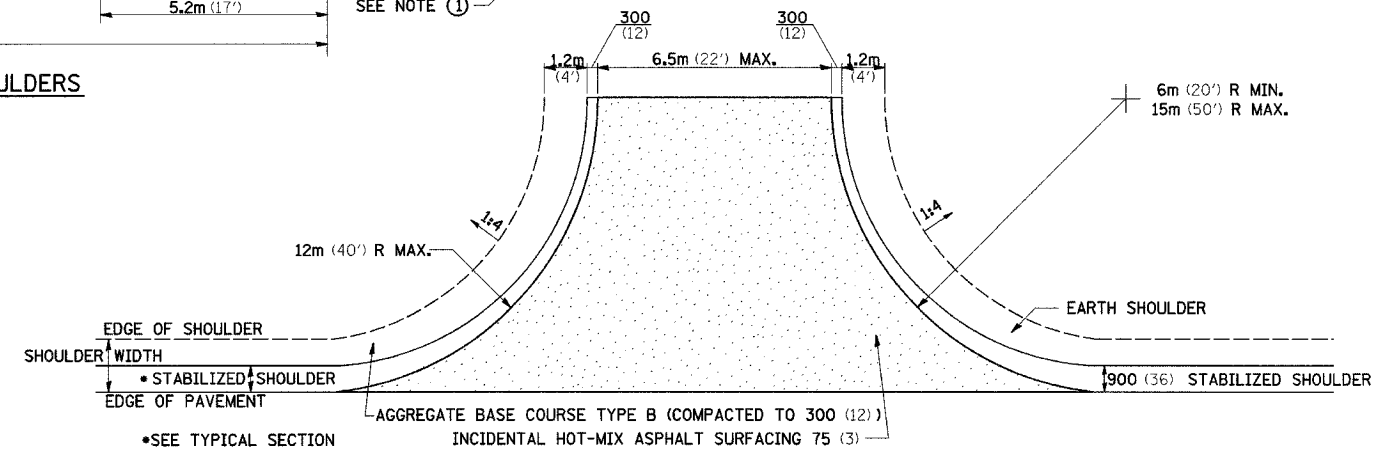
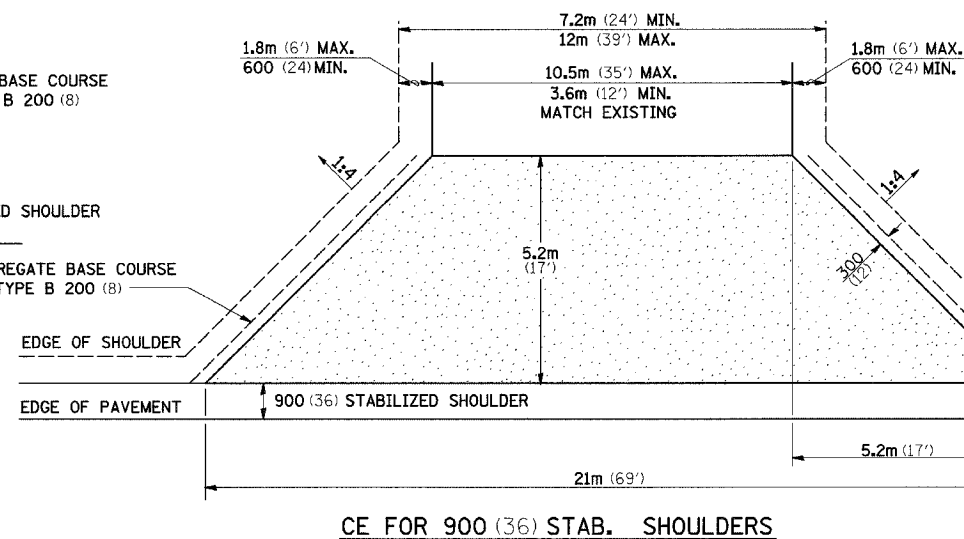

	6m (20') RADIUS			9m (30') RADIUS			12m (40') RADIUS		
	5.5m (18')	6m (20')	6.5m (22')	5.5m (18')	6m (20')	6.5m (22')	5.5m (18')	6m (20')	6.5m (22')
AGG BASE CSE T-B (TON)	20 (22.1)	21.6 (23.8)	23.1 (25.5)	37 (40.8)	39.5 (43.5)	42 (46.3)	57.9 (63.8)	61.3 (67.6)	64.7 (71.3)
INC HMA SURF 75 (3) (TON)	5.5 (6.1)	6.2 (6.8)	6.6 (7.25)	10.5 (11.6)	11.2 (12.4)	12.1 (13.3)	16.7 (18.4)	17.7 (19.5)	18.7 (20.6)
BIT PRIME CSE T-B (TON)	0.05 (0.06)	0.06 (0.07)	0.06 (0.07)	0.11 (0.12)	0.11 (0.12)	0.12 (0.13)	0.16 (0.18)	0.18 (0.20)	0.19 (0.21)

NOTE: USE 50 (2) INC. HMA SURF. ON EXISTING RETURNS

PLOT DATE = Wed Oct 19 15:25:54 2007  
 FILE NAME = c:\purojects\1208080\ad080808.dgn  
 PLOTTER = HPGL  
 REFERENCE = #REF#