

F.A.P. RTE.	SECTION	COUNTY	TOTAL SHEETS	SHEET NO.
308	(104-BY-1BR)	CARROLL	40	3
STA.	TO STA.			
FED. ROAD DIST. NO.	ILLINOIS	FED. AID PROJECT		

SCHEDULE OF QUANTITIES

TEMPORARY TRAFFIC CONTROL

LOCATION	70106500	70106700	70300100	70300520	70300570	70301000	70400100	70400200	Z0030250	Z0030350
	TEMPORARY BRIDGE TRAFFIC SIGNALS	TEMPORARY RUMBLE STRIP	SHORT TERM PAVEMENT MARKING	PAVEMENT MARKING TAPE, TYPE III 4"	PAVEMENT MARKING TAPE, TYPE III 24"	WORK ZONE PAVEMENT MARKING REMOVAL	TEMPORARY CONCRETE BARRIER	RELOCATE TEMPORARY CONCRETE BARRIER	IMPACT ATTENUATORS, TEMPORARY (NON-REDIRECTIVE), TEST LEVEL 3	IMPACT ATTENUATORS, RELOCATE (NON-REDIRECTIVE), TEST LEVEL 3
SN 008-0016 WEST	1	3	150	2500	24	690	118	118	1	1
SN 008-0016 EAST	1	3	150	2500	24	690	117	117	1	1
SUB-TOTAL	1	6	300	5000	48	1380	235	235	2	2

SHOULDER PAVEMENT

STATION FROM	STATION TO	20200100	20400800	31100910	40603310
		EARTH EXCAVATION	FURNISHED EXCAVATION	SUB-BASE GRANULAR MATERIAL, TYPE A 12"	HOT-MIX ASPHALT SURF. COURSE, MIX C, N50
562+70	565+87	77.5	20	282	50
566+95	570+04	77.5	20	282	50
SUB-TOTAL		155	40	564	100

PAVEMENT

STATION FROM	STATION TO	40600990	40603310	44000157	78300200
		TEMPORARY RAMPS	HOT-MIX ASPHALT, SURF. COURSE, MIX "C", N50	HOT-MIX ASPHALT SURFACE REMOVAL	RAISED REFLECTIVE PAVEMENT MARKER REMOVAL
565+66	566+20	24	34	144	1
566+60	567+14	24	34	144	1
SUB-TOTAL		48	68	288	2

GUARDRAIL

LOC.	63000000	63100167	63100087	63200310	63500105	78200410
	STEEL PLATE BEAM GUARDRAIL, TYPE A	TRAFFIC BARRIER TERMINAL, TYPE 1, SPECIAL (FLARED)	TRAFFIC BARRIER TERMINAL, TYPE 6A	GUARDRAIL REMOVAL	DELINEATORS	GUARDRAIL MARKERS, TYPE A
NW QUADRANT	37.5	1	1	127	1	1
SW QUADRANT	100	1	1	188	1	1
NE QUADRANT	100	1	1	188	1	1
SE QUADRANT	50	1	1	127	1	1
SUB-TOTAL	287.5	4	4	630	4	14

PAVEMENT MARKING

STATION FROM	STATION TO	78001110
		PAINT PAVEMENT MARKING-LINE 4"
559+39	569+39	5680
SUB-TOTAL		5680

2 PAINT APPLICATIONS REQUIRED

NOT SCHEDULED

28000400 PERIMETER EROSION BARRIER 1400 FT

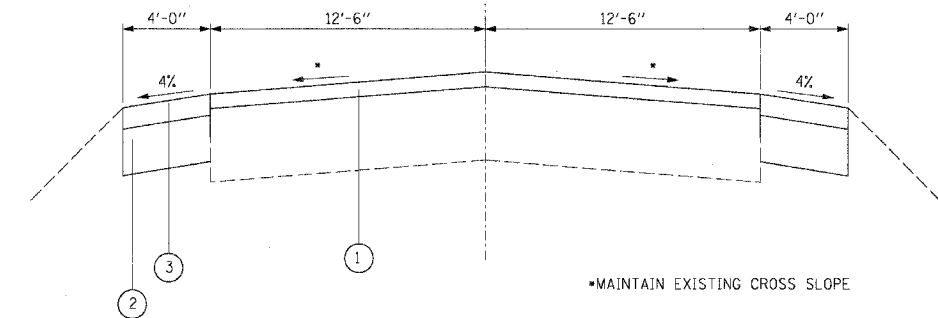

- 1 HOT MIX ASPHALT SURFACE REMOVAL, 2"
- 2" HOT MIX ASPHALT SURFACE COURSE, MIX "D", N70
- 2 SUB-BASE GRANULAR MATERIAL, TYPE A 12"
- 3 3" HOT-MIX ASPHALT SURFACE COURSE, MIX C, N50
PLACE IN 2 LIFTS

TYPICAL SECTION

REVISIONS		ILLINOIS DEPARTMENT OF TRANSPORTATION SCHEDULE OF QUANTITIES IL-84 OVER A DRAINAGE DITCH FAP ROUTE 308 SECTION (104-BY-1BR)D CARROLL COUNTY STATION 566+38 STRUCTURE NO. 008-0016
NAME	DATE	

SCALE: VERT. _____
HORIZ. _____
DATE 10/10/07

DRAWN BY CKL
CHECKED BY CAC