

| F.A.U. RTE.           | SECTION | COUNTY                    | TOTAL SHEETS | SHEET NO. |
|-----------------------|---------|---------------------------|--------------|-----------|
| 3887                  | AR-B    | KANE                      | 43           | 35        |
| STA.                  |         | TO STA.                   |              |           |
| FED. ROAD DIST. NO. 1 |         | ILLINOIS FED. AID PROJECT |              |           |

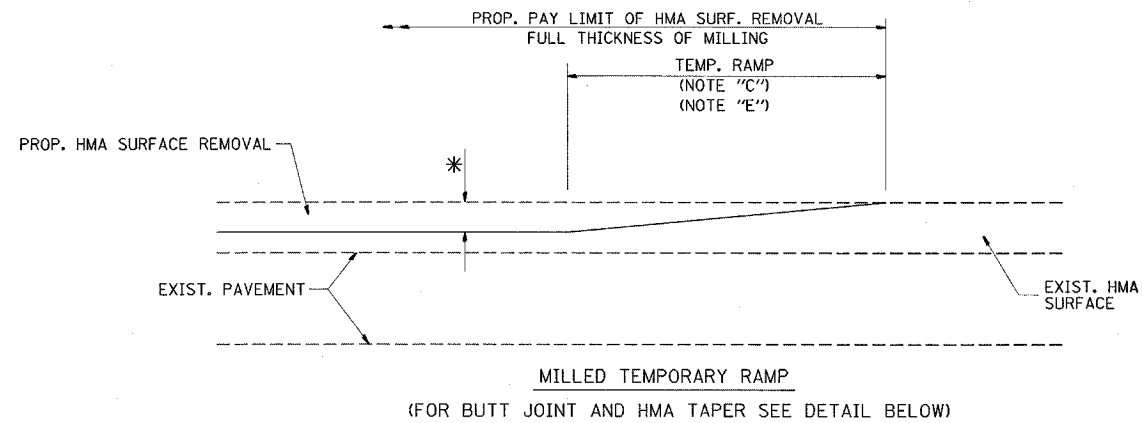

OPTION 1

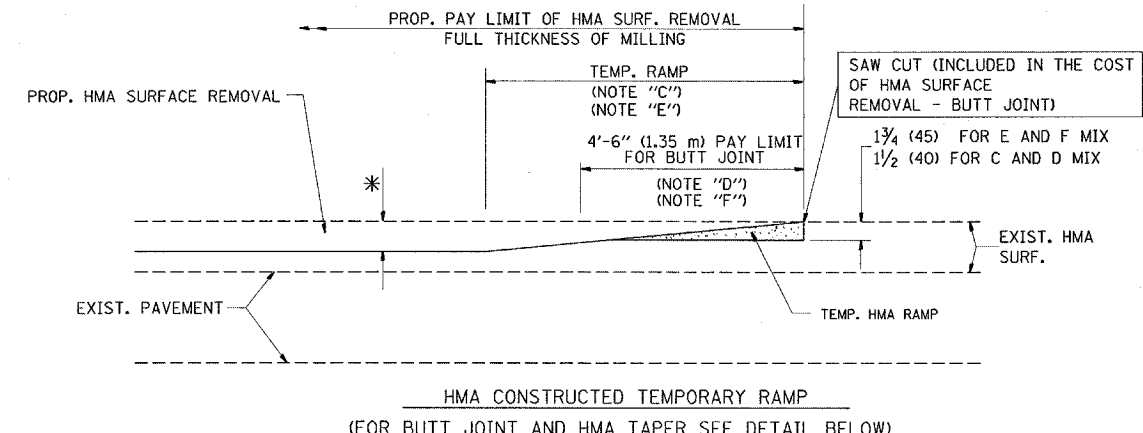

OPTION 2  
TYPICAL TEMPORARY RAMP

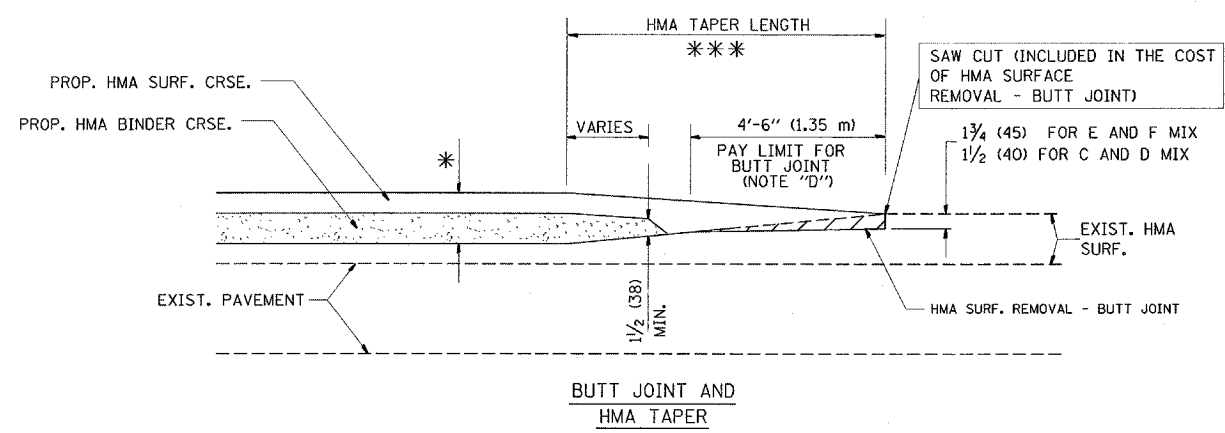

TYPICAL BUTT JOINT AND HMA TAPER FOR MILLING AND RESURFACING

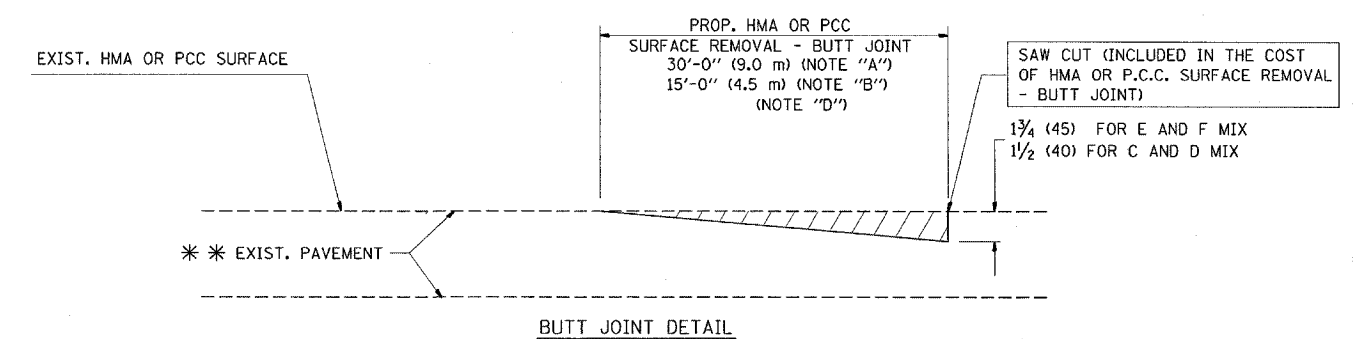

BUTT JOINT DETAIL

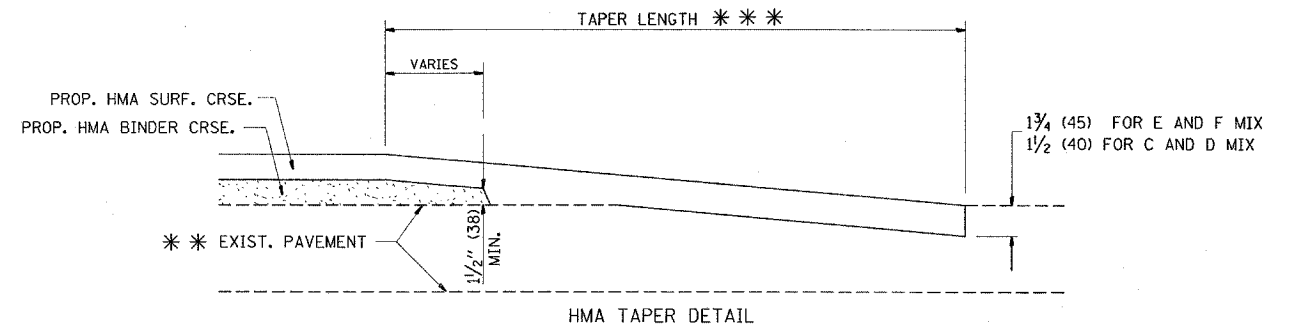

HMA TAPER DETAIL

TYPICAL BUTT JOINT AND HMA TAPER FOR RESURFACING ONLY

\*\* PC CONCRETE, HMA OR HMA RESURFACED PAVEMENT.

NOTES

- A: MAINLINE ROADWAYS AND MAJOR SIDE ROADS.
  - B: MINOR SIDE ROADS.
  - C: THE TEMP. RAMP SHALL BE CONSTRUCTED IMMEDIATELY UPON REMOVAL OF THE EXISTING HMA SURFACE.
  - D: THE BUTT JOINT SHALL BE CONSTRUCTED IMMEDIATELY PRIOR TO PLACING THE PROPOSED HMA COURSES.
  - E: TAPER THE TEMP. RAMP AT A RATE OF 3'-0" (900 mm) PER 1 INCH (25 mm) OF MILLING THICKNESS.
  - F: INSTALLATION AND REMOVAL OF THE 4'-6" (1.35 m) TEMP. RAMP IS INCLUDED IN COST OF HMA SURFACE REMOVAL - BUTT JOINT
  - G: SEE ARTICLE 406.08 AND 406.14 OF THE STANDARD SPECIFICATIONS FOR "HMA AND/OR PCC SURFACE REMOVAL, BUTT JOINT".
- \* SEE TYPICAL SECTIONS FOR MILLING THICKNESS.
- \*\* 20'-0" (6.1 m) PER 1 (25) RESURFACING (NOTE "A")  
10'-0" (3.0 m) PER 1 (25) RESURFACING (NOTE "B")

ALL DIMENSIONS ARE IN INCHES (MILLIMETERS) UNLESS OTHERWISE SHOWN.

BASIS OF PAYMENT:

THE BUTT JOINT WILL BE PAID FOR AT THE CONTRACT UNIT PRICE PER SQUARE YARD (SQUARE METER) FOR "HOT-MIX ASPHALT SURFACE REMOVAL - BUTT JOINT" OR FOR "PORTLAND CEMENT CONCRETE SURFACE REMOVAL - BUTT JOINT".

| REVISIONS  |          |
|------------|----------|
| NAME       | DATE     |
| M. DE YONG | 6-13-90  |
| M. DE YONG | 7-3-90   |
| M. DE YONG | 3-27-92  |
| R. SHAH    | 09/09/94 |
| R. SHAH    | 10/25/94 |
| A. ABBAS   | 03/21/97 |
| M. GOMEZ   | 04/06/01 |
| R. BORO    | 01/01/07 |

ILLINOIS DEPARTMENT OF TRANSPORTATION

BUTT JOINT AND HMA TAPER DETAILS

SCALE: VERT. NONE  
HORIZ.

DRAWN BY

CHECKED BY

BD400-05 (VI-BD32)

PLOT DATE = 11/6/2007  
 FILE NAME = \\sds\inf2\users\gelbennb\Drawtop\bd32.dgn  
 PLOT SCALE = 52.9411 / IN.  
 USER NAME = gelbennb