

HALF SECTION (TURN LANE VICINITY)
74TH STREET (WESTFIELD PLAZA BLVD.)
• MATCH EXISTING SLOPE

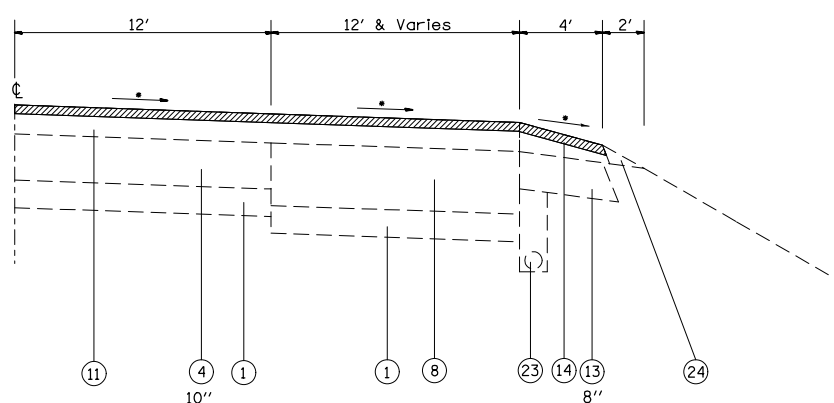

HALF SECTION (TURN LANE VICINITY)
11TH STREET
• MATCH EXISTING SLOPE

- LEGEND**
- ① EXISTING SUB-BASE GRANULAR MATERIAL, VARIES 4" TO 12"
 - ② EXISTING BASE COURSE, 13.5"
 - ③ EXISTING LIME MODIFIED SOIL, 12"
 - ④ EXISTING PCC PAVEMENT
 - ⑤ OMIT
 - ⑥ EXISTING PCC JOINTED PAVEMENT, 14"
 - ⑦ EXISTING PCC BASE COURSE WIDENING, 9"
 - ⑧ EXISTING WIDENING
 - ⑨ EXISTING HMA PAVEMENT (FULL DEPTH)
 - ⑩ EXISTING HMA RESURFACING, 6" TO 7.5"
 - ⑪ EXISTING HMA RESURFACING
 - ⑫ EXISTING HMA BINDER COURSE, 12"
 - ⑬ EXISTING HMA SHOULDER
 - ⑭ EXISTING HMA SHOULDER RESURFACING, VAR. DEPTH
 - ⑮ EXISTING CONCRETE MEDIAN
 - ⑯ EXISTING CONCRETE CURB, SPECIAL, 12"
 - ⑰ EXISTING CONCRETE CURB
 - ⑱ EXISTING PCC MEDIAN SURFACE, 4"
 - ⑲ EXISTING CONCRETE BARRIER
 - ⑳ EXISTING HMA SHOULDER CURB
 - ㉑ EXISTING CONCRETE GUTTER
 - ㉒ EXISTING CONCRETE CURB & GUTTER
 - ㉓ EXISTING PIPE UNDERDRAINS
 - ㉔ EXISTING AGGREGATE SHOULDERS
 - ㉕ PROPOSED POLYMER HMA SURFACE COURSE, MIX E, N90, 2 1/4"
 - ㉖ PROPOSED HMA SHOULDERS, 2 1/4"
 - ㉗ PROPOSED AGGREGATE SHOULDER WEDGE, TYPE B
 - ㉘ PROPOSED HMA SHOULDER CURB
- HMA SHOULDER CURB REMOVAL
 HMA SURFACE REMOVAL, 2"
 HMA SURFACE REMOVAL, 2.25"
 SEE PLAN SHEETS FOR AREAS OF MILLING TRANSITIONS.

FILE NAME =	USER NAME = conoverpj	DESIGNED -	REVISED -	STATE OF ILLINOIS DEPARTMENT OF TRANSPORTATION	EXISTING TYPICAL SECTIONS			F.A.P. RTE.	SECTION	COUNTY	TOTAL SHEETS	SHEET NO.	
et:\pw\work\p\dot\conoverpj\d0340760\d076g38-sh-t\typical.dgn		DRAWN -	REVISED -		SCALE:	SHEET NO. 9 OF 13 SHEETS	STA.	TO STA.	103	(29-1,28-1,28-2,26-1)RS-2	ST. CLAIR	97	15
		CHECKED -	REVISED -					CONTRACT NO. 76G38					
		DATE -	REVISED -										