



LEGEND

- ① EXISTING SUB-BASE GRANULAR MATERIAL, VARIES 4" TO 12"
- ② EXISTING BASE COURSE, 13.5"
- ③ EXISTING LIME MODIFIED SOIL, 12"
- ④ EXISTING PCC PAVEMENT
- ⑤ OMIT
- ⑥ EXISTING PCC JOINTED PAVEMENT, 14"
- ⑦ EXISTING PCC BASE COURSE WIDENING, 9"
- ⑧ EXISTING WIDENING
- ⑨ EXISTING HMA PAVEMENT (FULL DEPTH)
- ⑩ EXISTING HMA RESURFACING, 6" TO 7.5"
- ⑪ EXISTING HMA RESURFACING
- ⑫ EXISTING HMA BINDER COURSE, 12"
- ⑬ EXISTING HMA SHOULDER
- ⑭ EXISTING HMA SHOULDER RESURFACING, VAR. DEPTH
- ⑮ EXISTING CONCRETE MEDIAN
- ⑯ EXISTING CONCRETE CURB, SPECIAL, 12"
- ⑰ EXISTING CONCRETE CURB
- ⑱ EXISTING PCC MEDIAN SURFACE, 4"
- ⑲ EXISTING CONCRETE BARRIER
- ⑳ EXISTING HMA SHOULDER CURB
- ㉑ EXISTING CONCRETE GUTTER
- ㉒ EXISTING CONCRETE CURB & GUTTER
- ㉓ EXISTING PIPE UNDERDRAINS
- ㉔ EXISTING AGGREGATE SHOULDERS
- ㉕ PROPOSED POLYMER HMA SURFACE COURSE, MIX E, N90, 2 1/4"
- ㉖ PROPOSED HMA SHOULDERS, 2 1/4"
- ㉗ PROPOSED AGGREGATE SHOULDER WEDGE, TYPE B
- ㉘ PROPOSED HMA SHOULDER CURB

-  HMA CURB REMOVAL
-  HMA SURFACE REMOVAL, 2"
-  HMA SURFACE REMOVAL, 2.25"

SEE PLAN SHEETS FOR AREAS OF MILLING TRANSITIONS.

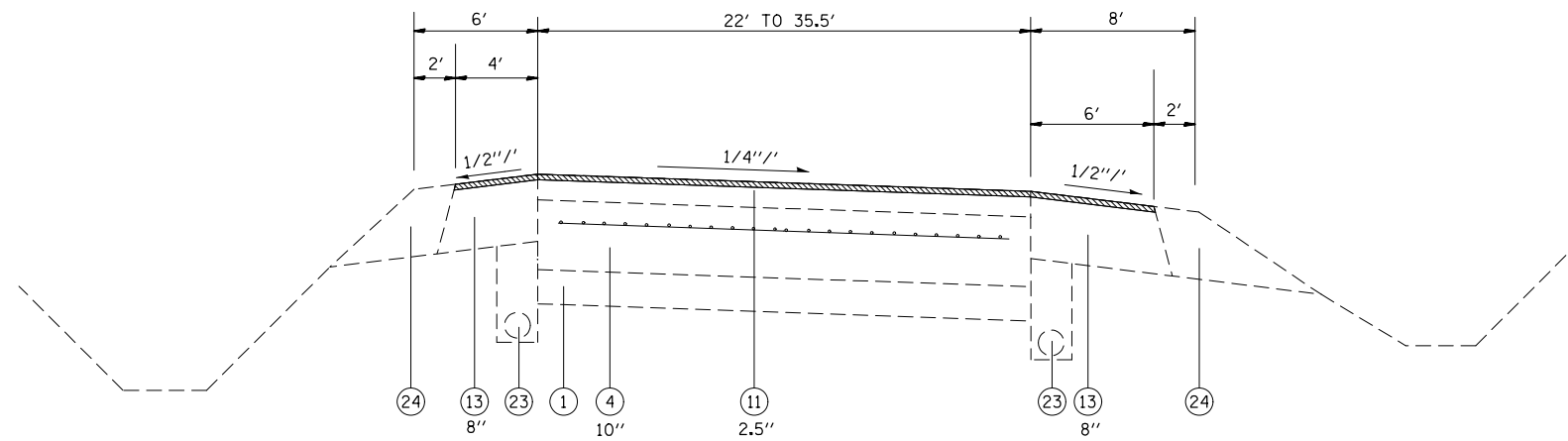

IL 13/15 - LINE B

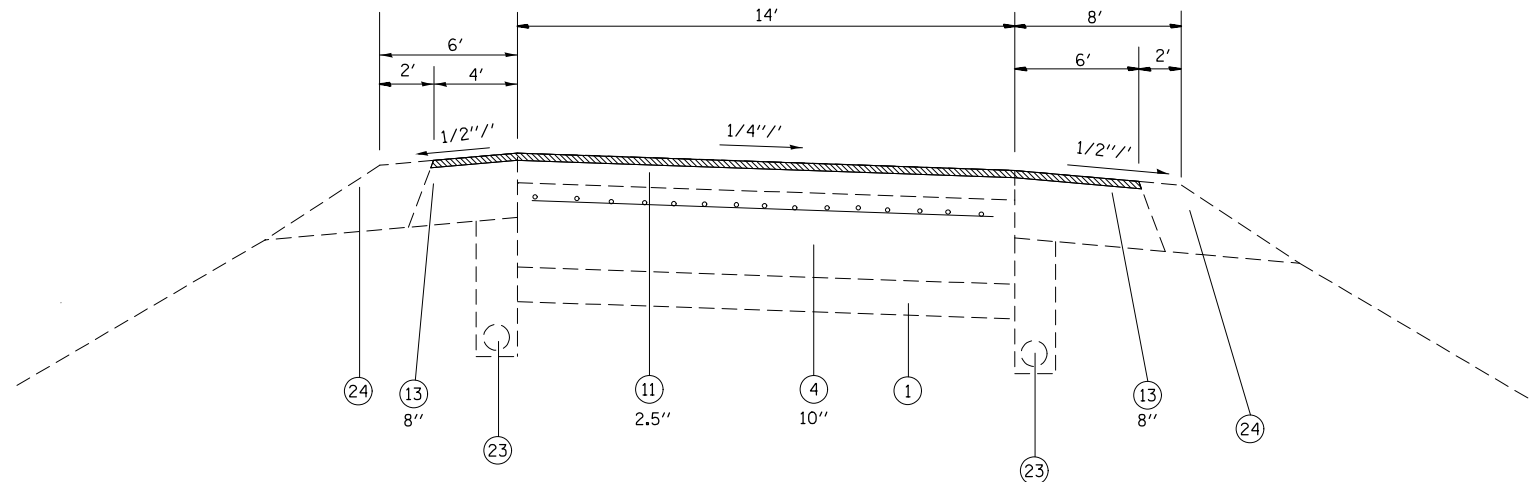

IL 13/15 - INTERCHANGE RAMPs

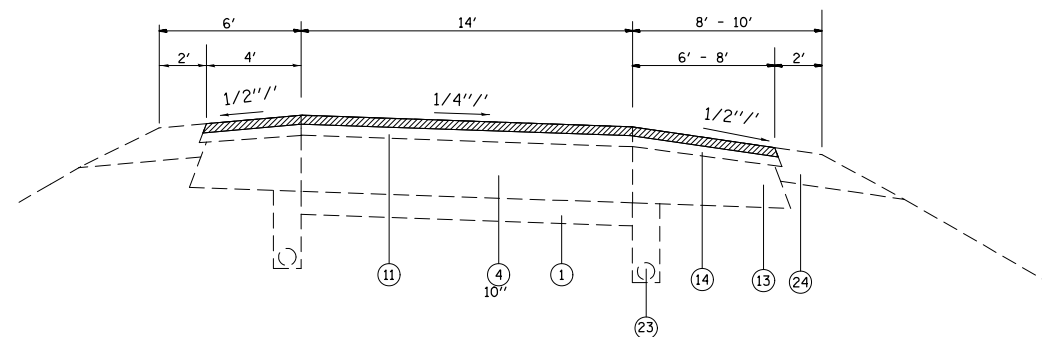

FRANK SCOTT PKY.

FILE NAME =	USER NAME = conoverpj	DESIGNED -	REVISED -
et:\pw\work\p\dot\conoverpj\d0340733\d076g37-sh-t-typical.dgn		DRAWN -	REVISED -
	PLOT SCALE = 100.0000' / 1in.	CHECKED -	REVISED -
	PLOT DATE = 10/18/2013	DATE -	REVISED -

**STATE OF ILLINOIS
DEPARTMENT OF TRANSPORTATION**

EXISTING TYPICAL SECTIONS

SCALE: SHEET NO. 12 OF 14 SHEETS STA. TO STA.

F.A.P. RTE.	SECTION	COUNTY	TOTAL SHEETS	SHEET NO.
103	(29-1,28-1,28-2,26-1)RS-1	ST. CLAIR	96	17
FED. ROAD DIST. NO. ILLINOIS FED. AID PROJECT			CONTRACT NO. 76G37	