

NOTE: COLLECTOR-DISTRIBUTOR SHALL BE ABBREVIATED C-D.

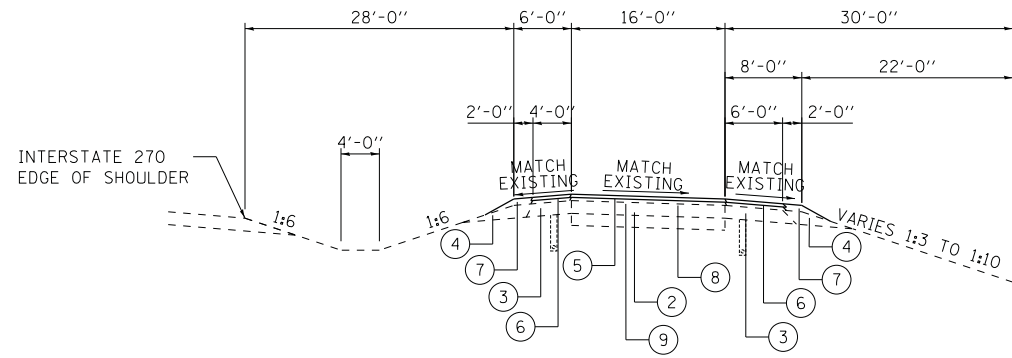

J I-270 COLLECTOR-DISTRIBUTOR ROAD SECTION

STA 449+95.80 TO STA 462+54.66
STA 472+98.78 TO STA 482+56.48

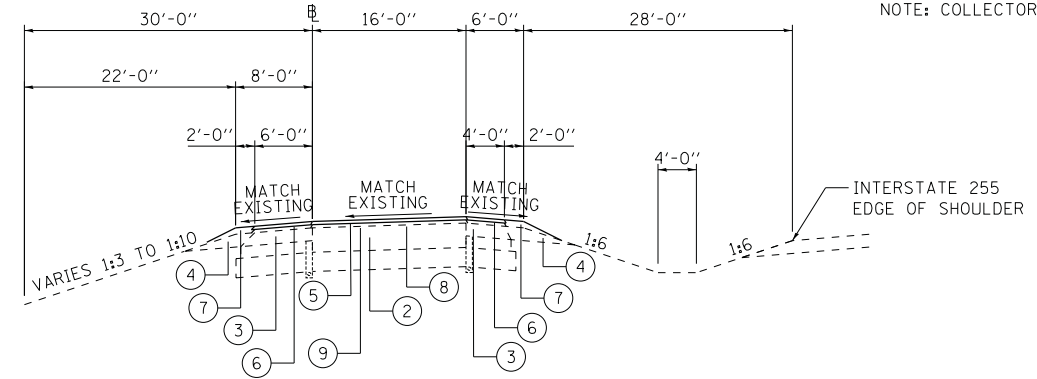

K I-255 COLLECTOR-DISTRIBUTOR ROAD SECTION

STA 1593+72.56 TO STA 1610+89.27
STA 1622+49.55 TO STA 1627+70.07

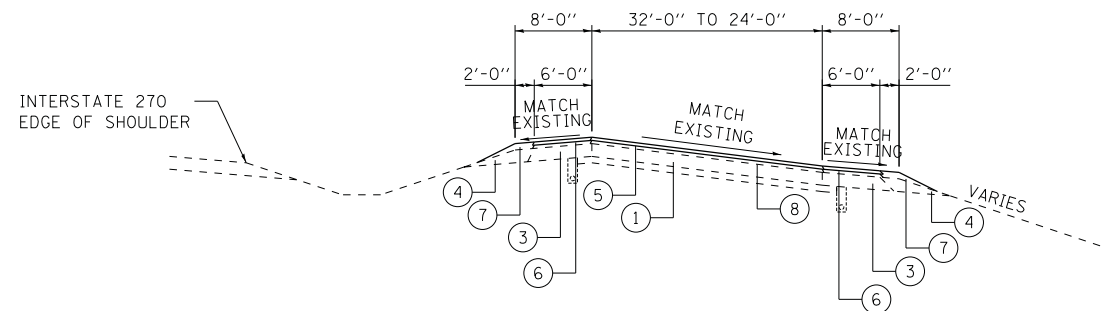

L I-270 COLLECTOR-DISTRIBUTOR ROAD AND RAMP SECTION

STA 439+19.37 TO STA 446+23.54
STA 485+55.61 TO STA 489+37.65

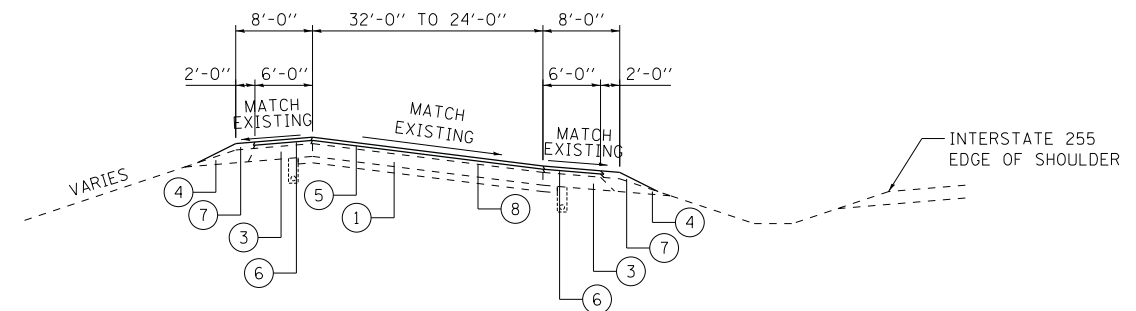

M I-255 COLLECTOR-DISTRIBUTOR ROAD AND RAMP SECTION

STA 1588+96.04 TO STA 1590+70.38

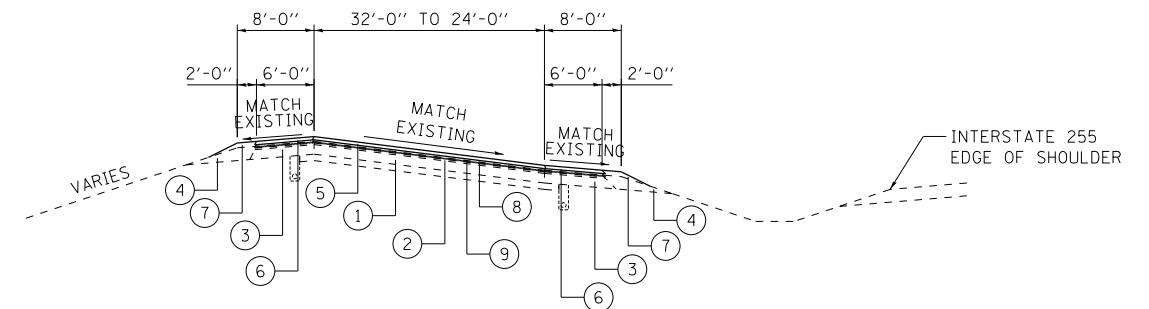

N I-255 COLLECTOR-DISTRIBUTOR ROAD AND RAMP SECTION WITH INLAY/OVERLAY

STA 1586+88.95 TO STA 1588+96.04

- ① EXISTING PCC PAVEMENT
- ② EXISTING BITUMINOUS PAVEMENT
- ③ EXISTING BITUMINOUS SHOULDER
- ④ EXISTING AGGREGATE SHOULDERS
- ⑤ POLYMERIZED HOT-MIX ASPHALT SURFACE COURSE, STONE MATRIX ASPHALT, N80 - (2 - 2" LIFTS)
- ⑥ HOT-MIX ASPHALT SHOULDERS, (2 - 2" LIFTS)
- ⑦ AGGREGATE WEDGE SHOULDER, TYPE B - (4" TO 0")
- ⑧ BITUMINOUS MATERIALS (PRIME COAT) AND AGGREGATE (PRIME COAT)
- ⑨ HMA/PCC SURFACE REMOVAL (SEE SCHEDULE FOR THICKNESS AND LOCATIONS)
- ⑩ PIPE UNDERDRAINS, 4"

EXISTING PAVEMENT AND SHOULDER THICKNESSES				
I-255 C-D ROADWAY			PAVEMENT	SHOULDER
1592+50.00	TO	1594+25.38	9" CRPCCP	9" BITUMINOUS
1594+25.38	TO	1627+70.07	15.25" BITUMINOUS	8" BITUMINOUS
I-270 C-D ROADWAY			PAVEMENT	SHOULDER
439+19.37	TO	450+44.76	9" CRPCCP	9" BITUMINOUS
450+44.76	TO	482+04.48	15.5" BITUMINOUS	8" BITUMINOUS
482+04.48	TO	489+37.65	11" JRPCCP	11" BITUMINOUS

FROM EXISTING PLANS, ACTUAL FIELD CONDITIONS MAY VARY.