

RTE.	SECTION	COUNTY	TOTAL SHEETS	SHEET NO
619	*	PUTNAM	77	45

FED. ROAD DIST. NO. ILLINOIS FED. AID PROJECT-
 126 BR, CR

CONTRACT NO. 68740

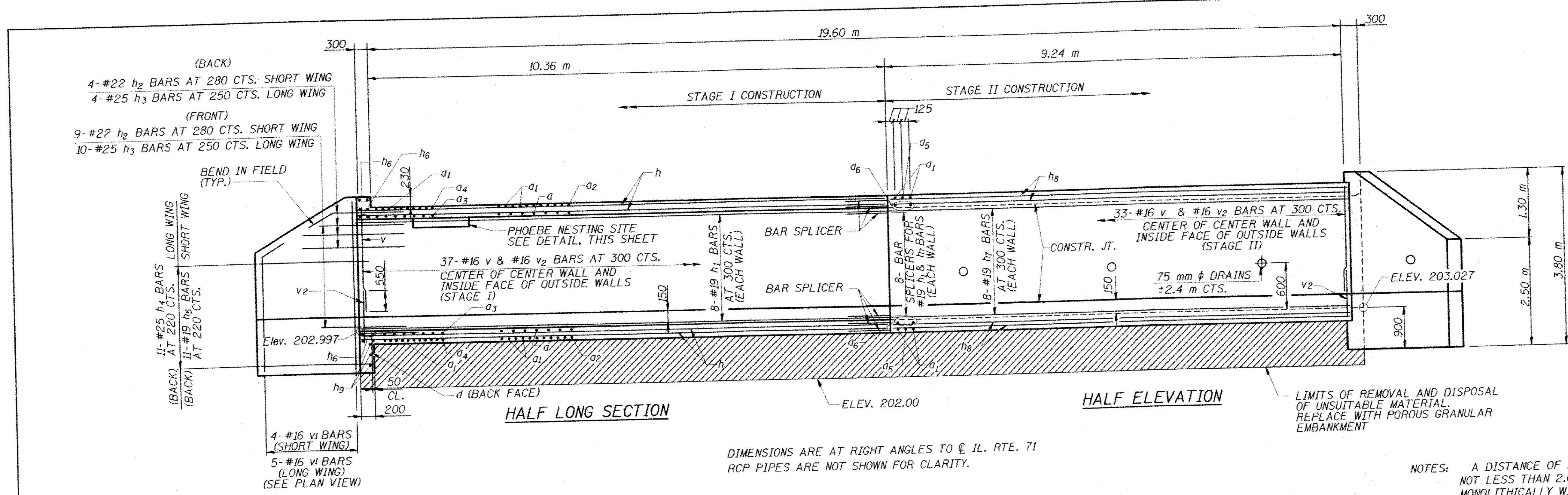

DIMENSIONS ARE AT RIGHT ANGLES TO C. IL. RTE. 71
 RCP PIPES ARE NOT SHOWN FOR CLARITY.

LIMITS OF REMOVAL AND DISPOSAL OF UNSUITABLE MATERIAL. REPLACE WITH POROUS GRANULAR EMBANKMENT

NOTES: A DISTANCE OF HALF THE LENGTH OF THE WINGWALL BUT NOT LESS THAN 2.0 m OF THE BARREL SHALL BE POURED MONOLITHICALLY WITH THE WINGWALLS.
 ALL DIMENSIONS ARE IN MILLIMETERS (mm) EXCEPT AS NOTED.

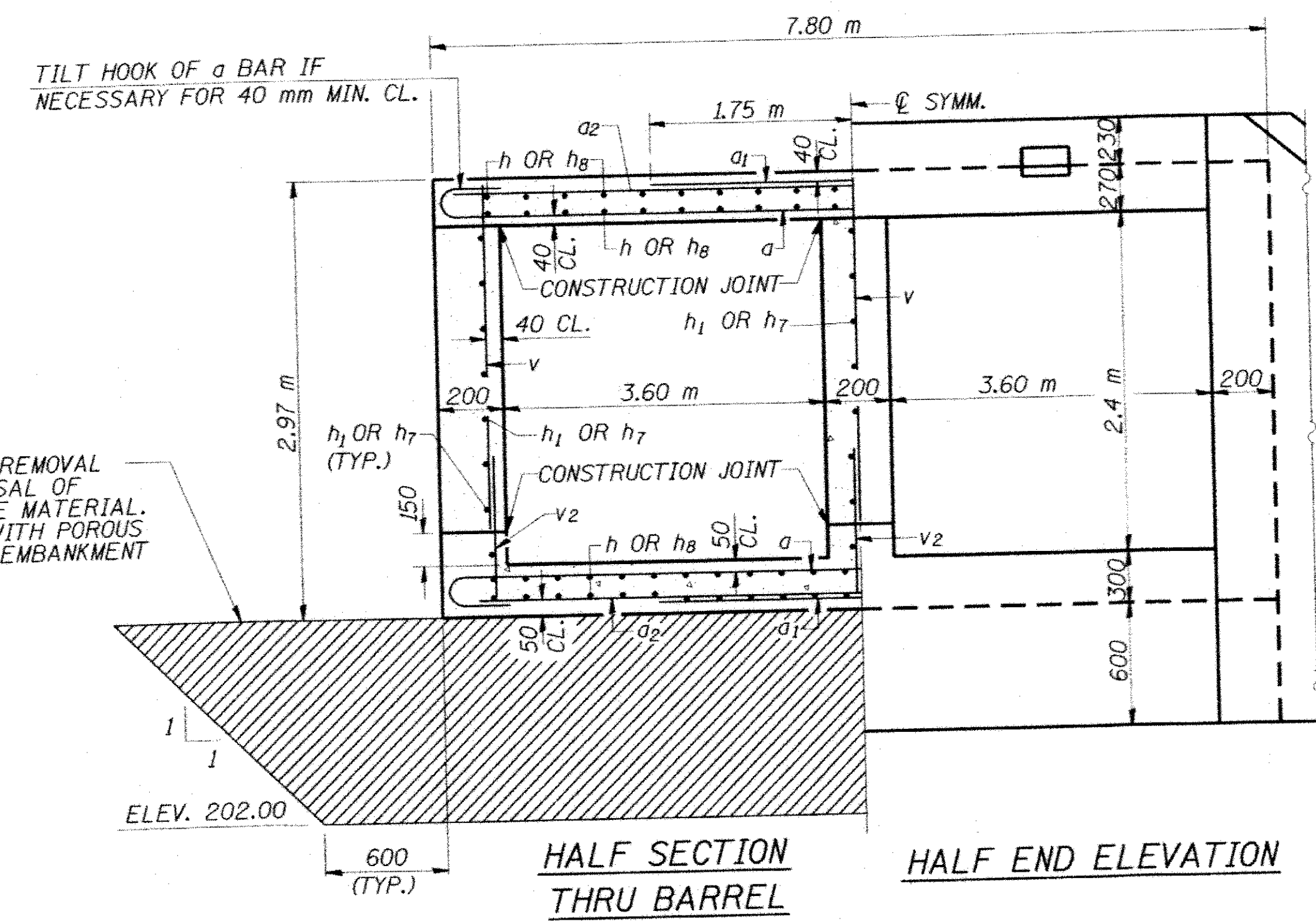

LIMITS OF REMOVAL AND DISPOSAL OF UNSUITABLE MATERIAL. REPLACE WITH POROUS GRANULAR EMBANKMENT

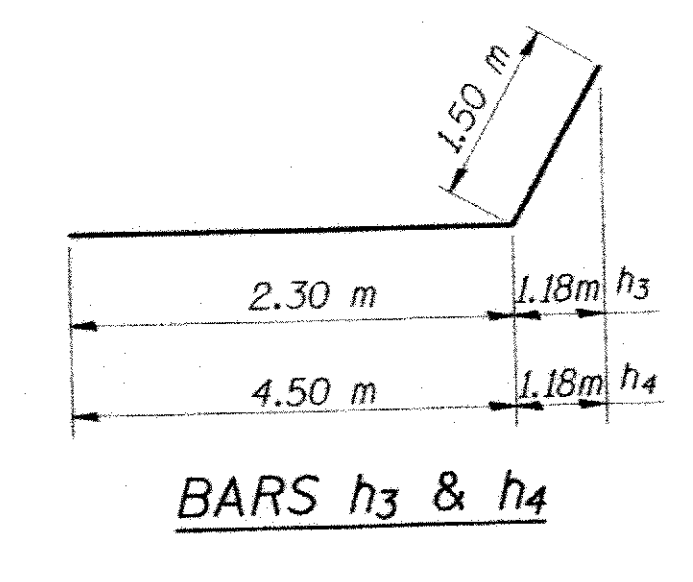
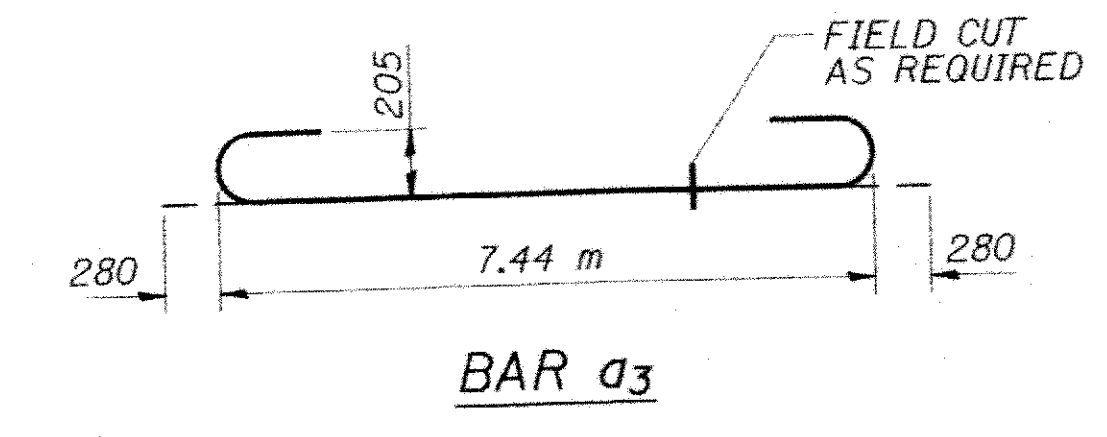
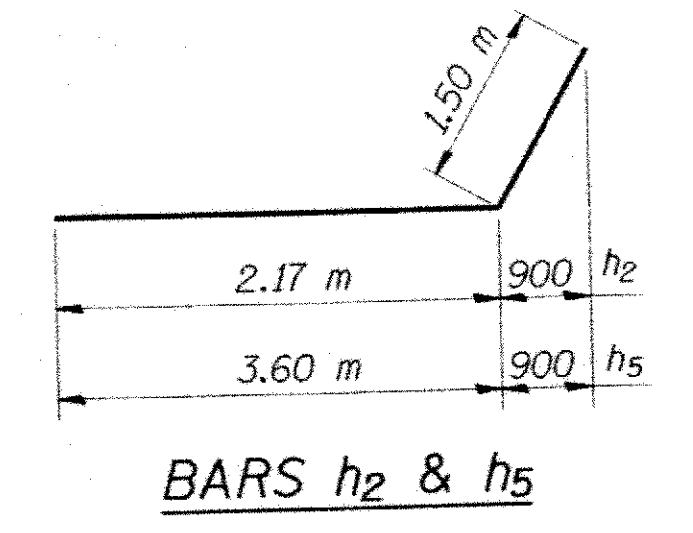
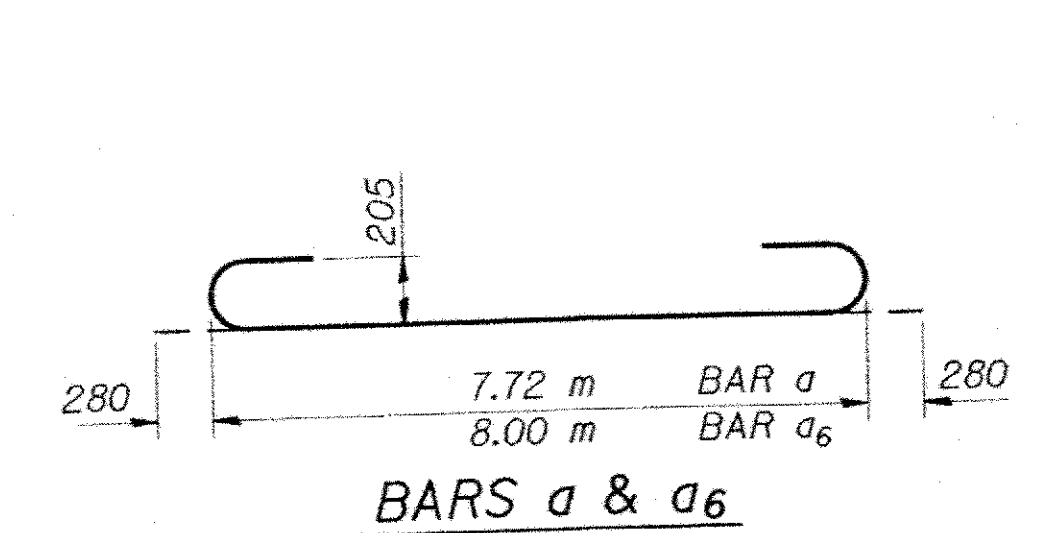

BILL OF MATERIAL

Bar	No.	Size	Length (m)	Shape
a	134	#25	8.28	C
a1	144	#25	3.50	—
a2	112	#16	7.72	—
a3	28	#25	8.00	C
a4	24	#16	7.44	—
a5	4	#16	8.00	—
a6	8	#25	8.56	C
d	50	#16	1.32	L
h	90	#16	10.80	—
h1	24	#19	10.80	—
h2	26	#22	3.67	—
h3	28	#25	3.80	—
h4	22	#25	6.00	—
h5	22	#19	5.10	—
h6	12	#19	7.95	—
h7	24	#19	9.77	—
h8	90	#16	9.77	—
h9	6	#16	7.95	—
v	214	#16	2.42	—
v1	18	#16	3.68	—
v2	214	#16	0.80	—
v3	16	#16	0.90	—
Concrete Box Culverts		m ³	149.8	
Reinforcement Bars		kg	16,290	

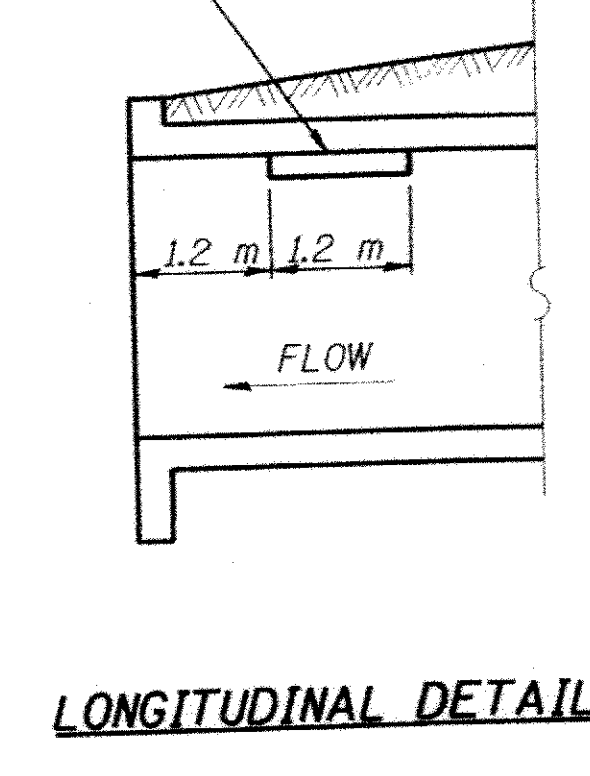
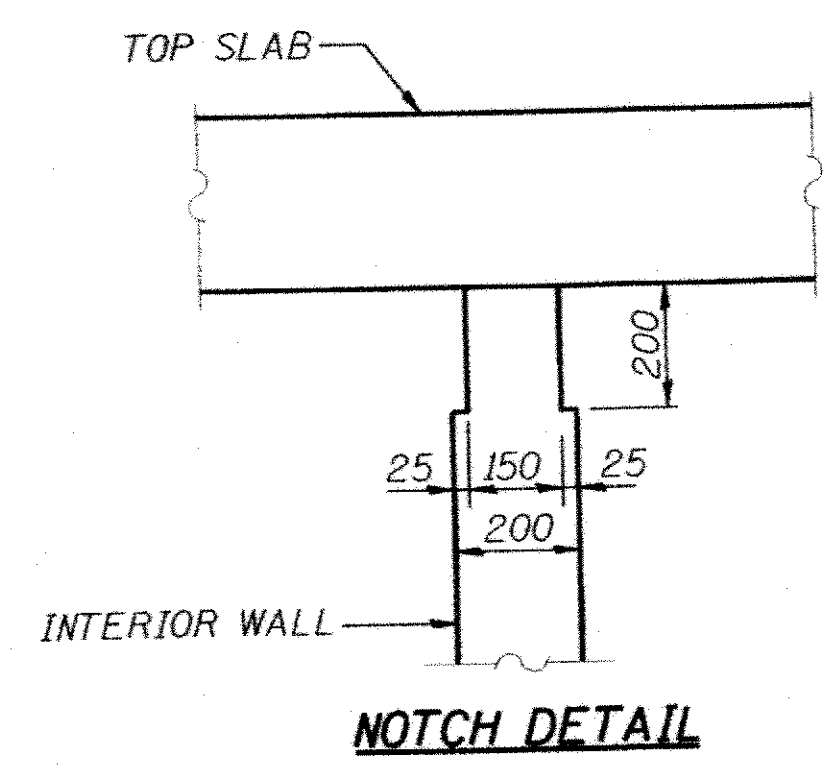
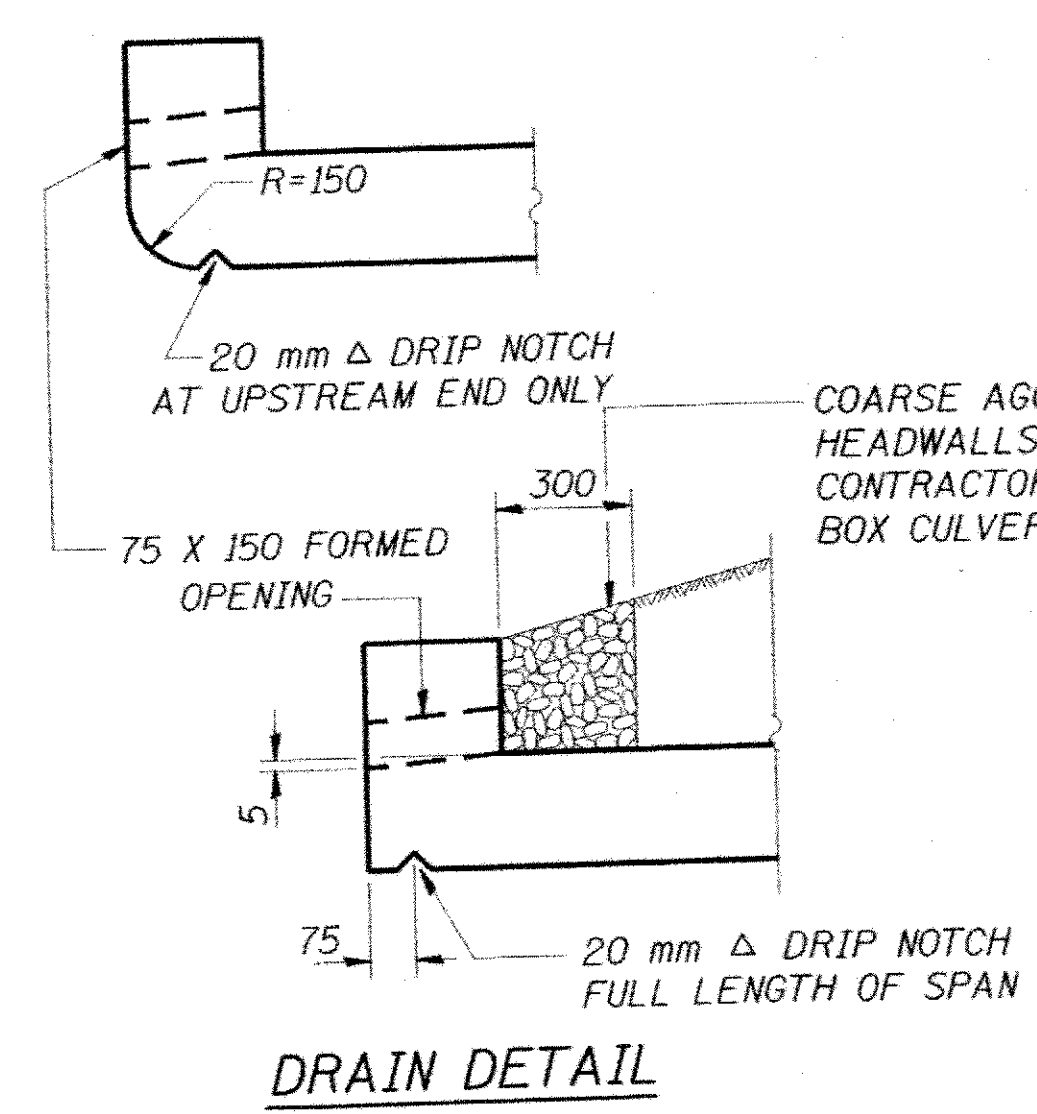

PHOEBE NESTING SITE DETAILS (DOWNSTREAM END ONLY)

REVISIONS	
NAME	DATE

ILLINOIS DEPARTMENT OF TRANSPORTATION
SECTIONS AND DETAILS
 ILLINOIS ROUTE 71 OVER DRAINAGE DITCH
 F.A.P. RT. 619 - SECTION 120 BR
 PUTNAM COUNTY
 STATION 12+530
 STRUCTURE No. 078-2007

DESIGNED BY: MV
 CHECKED BY: SG
 DATE: 09/21/09

DRAWN BY: KDS
 CHECKED BY: MV

TranSystems

FILE: g:\401\2000\0003902\cond\culv_078-2007\0782007.dwg