

INFORMATIONAL WARNING SIGN (FOR NARROW TRAVEL LANES)

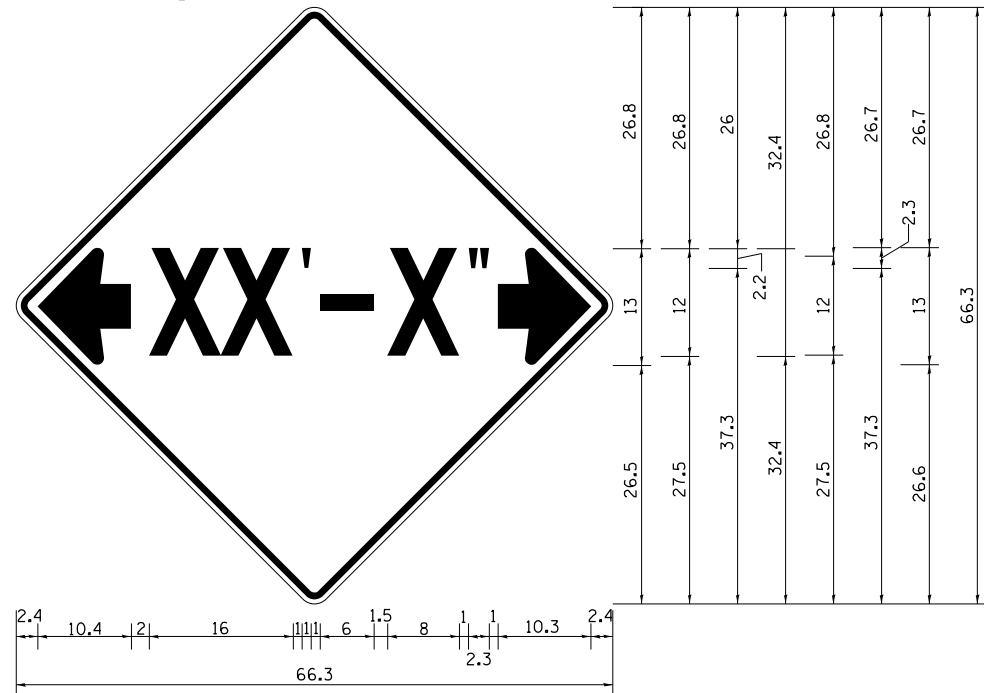

NOTES
 W12-2 - Horizontal Clearance Sign
 48.0" across sides, 1.9" Radius,
 0.8" Border, 0.5" Indent, Black on
 Orange; Standard Arrow Custom
 10.4" X 8.1" 180° Black 11 Inch
 D Series Lettering; Standard Arrow
 Custom 10.4" X 8.1" 0°

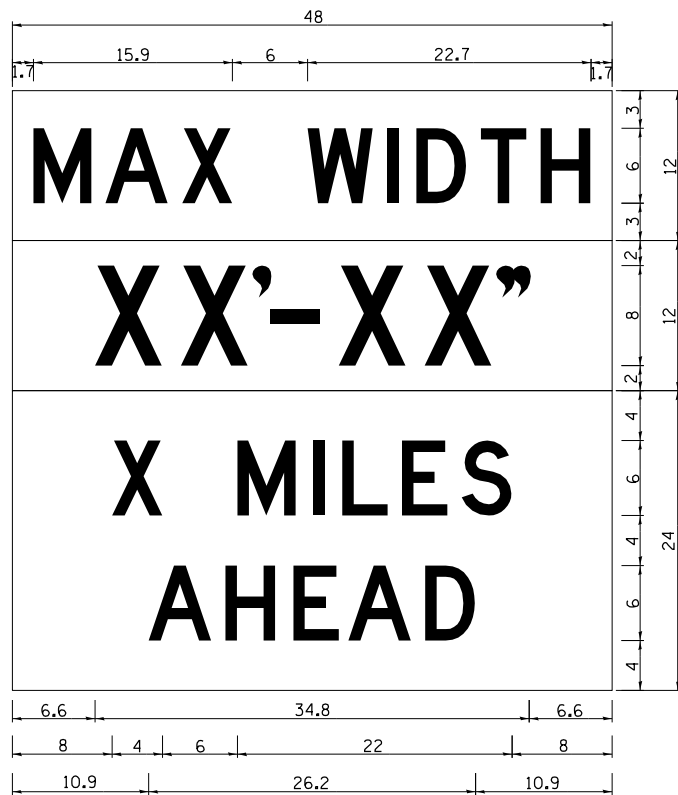

W12-1103 (Width is 8D);
 No border, Black on White;
 [MAX WIDTH] D;

No border, Black on Orange;
 [XX'-XX''] D;

No border, Black on White;
 [X MILES] D; [AHEAD] D;

All work to furnish and install these signs shall be included in the cost of the Traffic Control Standards and shall not be paid for separately.

ALL DIMENSIONS ARE IN INCHES UNLESS OTHERWISE NOTED.

REVISED - 5-15-09

WITNESS MARKER FOR PERMANENT SURVEY MARKERS, TYPE II

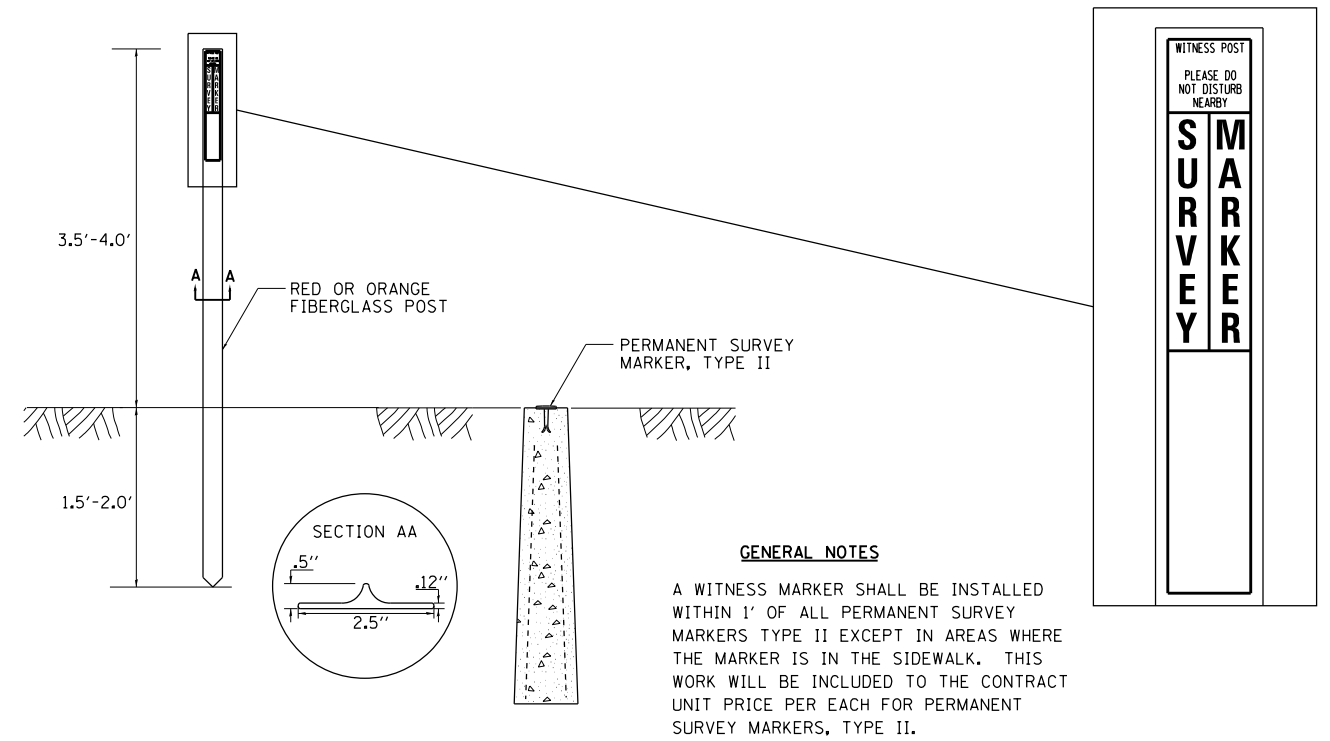

PERMANENT SURVEY MARKERS, TYPE II

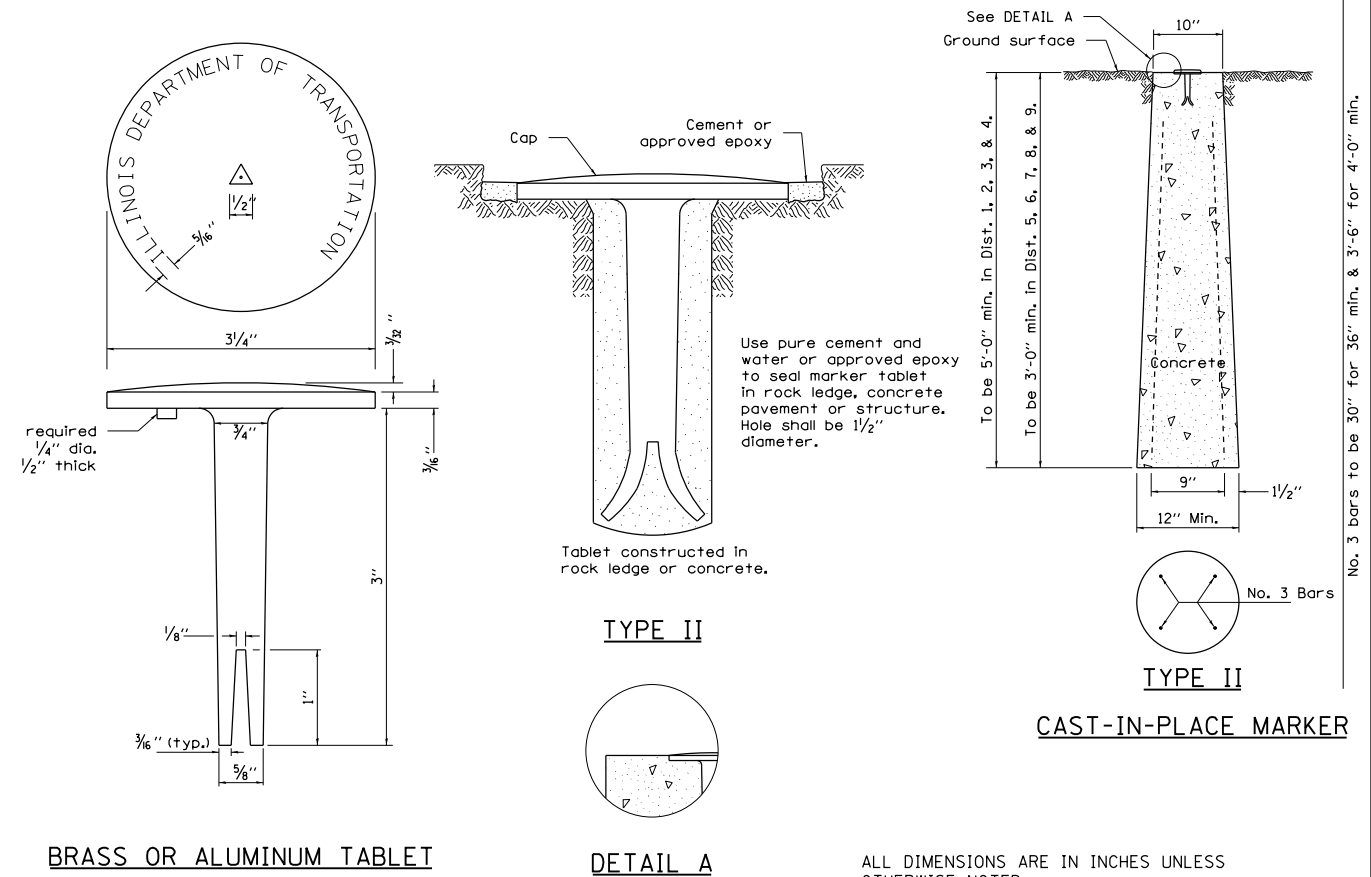

BRASS OR ALUMINUM TABLET

DETAIL A

ALL DIMENSIONS ARE IN INCHES UNLESS OTHERWISE NOTED.

REVISED - 10-14-11	REGION 2 / DISTRICT 2 STANDARD		F.A.P. RTE.	SECTION	COUNTY	TOTAL SHEETS	SHEET NO.
REVISED -	SCALE: 40,000' / 1"	SHEET NO. OF SHEETS STA. TO STA.	650	104T-3	JoDAVISS	97	75
REVISED -			CONTRACT NO.				
REVISED -			FED. ROAD DIST. NO. ILLINOIS FED. AID PROJECT				