

**BOX CULVERT DETAILS
IL RTE 78
F.A.P. RTE 642 SECTION 104T-3
JO DAVIESS COUNTY
STA. 912 + 26
STR. NO. 043-1098**

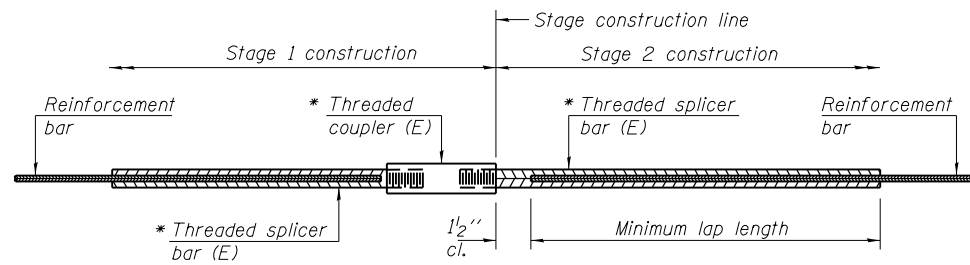

STANDARD BAR SPLICER ASSEMBLY

Bar size to be spliced	Minimum Lap Lengths - For Splicers					
	Table 1	Table 2	Table 3	Table 4	Table 5	Table 6
3, 4	1'-5"	1'-11"	2'-1"	2'-4"	2'-7"	2'-11"
5	1'-9"	2'-5"	2'-7"	2'-11"	3'-3"	3'-8"
6	2'-1"	2'-11"	3'-1"	3'-6"	3'-10"	4'-5"
7	2'-9"	3'-10"	4'-2"	4'-8"	5'-2"	5'-10"
8	3'-8"	5'-1"	5'-5"	6'-2"	6'-9"	7'-8"
9	4'-7"	6'-5"	6'-10"	7'-9"	8'-7"	9'-8"

- Table 1: Black bar, 0.8 Class C
- Table 2: Black bar, Top bar lap, 0.8 Class C
- Table 3: Epoxy bar, 0.8 Class C
- Table 4: Epoxy bar, Top bar lap, 0.8 Class C
- Table 5: Epoxy bar, Class C
- Table 6: Epoxy bar, Top bar top, Class C

Threaded splicer bar length = min. lap length + 1 1/2" + thread length

* Epoxy not required on Bar Splicer Assembly components used in conjunction with black bars.

Location	Bar size	No. assemblies required	Table for minimum lap length
Top Slab	#4	20	5
Bottom Slab	#4	20	5
Walls	#4	16	5

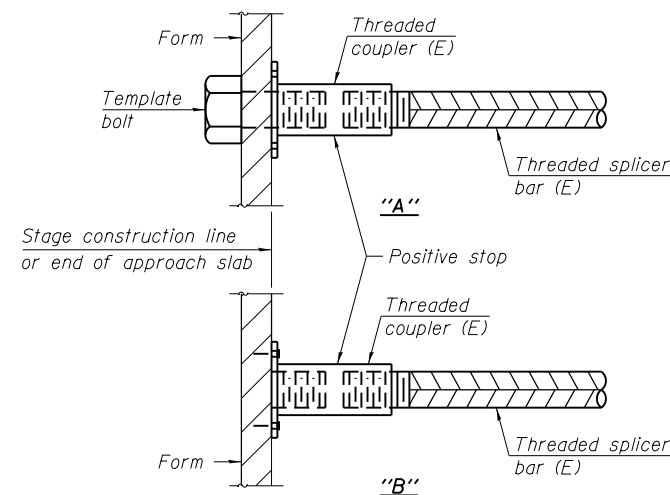

INSTALLATION AND SETTING METHODS

"A" : Set bar splicer assembly by means of a template bolt.
 "B" : Set bar splicer assembly by nailing to wood forms or cementing to steel forms.
 (E) : Indicates epoxy coating.

GENERAL NOTES

- All work and materials shall be in accordance with the Illinois Department of Transportation (IDOT) Standard Specifications for Road and Bridge Construction adopted January 1, 2012 and latest supplemental specifications and recurring special provisions, unless noted otherwise on these plans or special provisions.
- The Contractor shall verify all dimensions in the field prior to commencing work. The engineer shall be notified of any discrepancies which may exist, prior to proceeding with the work.
- Any information concerning type or location of underground and other utilities is not guaranteed to be accurate or all inclusive. The Contractor is responsible for making his own determinations as to the type and location of the utilities as may be necessary to avoid damage thereto. Contractor shall call J.U.L.I.E. prior to excavation.
- The Contractor is responsible for design, installation and removal of all excavation support systems.
- The excavation and work area shall be properly drained at all times during construction. All wet, loose, frozen or other unsuitable material shall be removed prior to placement of concrete or compacted backfill. The cost of any pumping required shall be included in the cost of "Concrete Box Culverts".
- It shall be the responsibility of the Contractor to divert the stream flow during construction in order to keep the construction areas free of water. The method of water diversion shall be subject to the approval of the Engineer and cost shall be included with "Concrete Box Culverts".

CAST-IN-PLACE CONCRETE NOTES

- All cast-in-place concrete work shall be in accordance with Section 540 of the Illinois Department of Transportation (IDOT) Standard Specifications for Road and Bridge Construction adopted January 1, 2012, supplemental specifications and recurring special provisions and as noted below.
- Reinforcement bars conform to the requirements of ASTM A 706 GR60.
- Exposed edges of cast-in-place concrete shall be beveled 3/4".
- All construction joints shall be bonded.
- Concrete mix designs shall be submitted to the Engineer for review and approval a minimum of 7 days prior to ordering or placing concrete.
- Backfill material on all sides of the box shall be compacted in accordance with Section 502 using walk behind tampers.
- Concrete Required f'c=3500 psi.

BAR SPLICER NOTES

Splicer bars shall be deformed with threaded ends and have a minimum 60 ksi yield strength.
 All reinforcement shall be lapped and tied to the splicer bars.
 Bar splicer assemblies shall be epoxy coated according to the requirements for reinforcement bars. See Section 508 of the Standard Specifications.
 See approved list of bar splicer assemblies and mechanical splicers for alternatives.

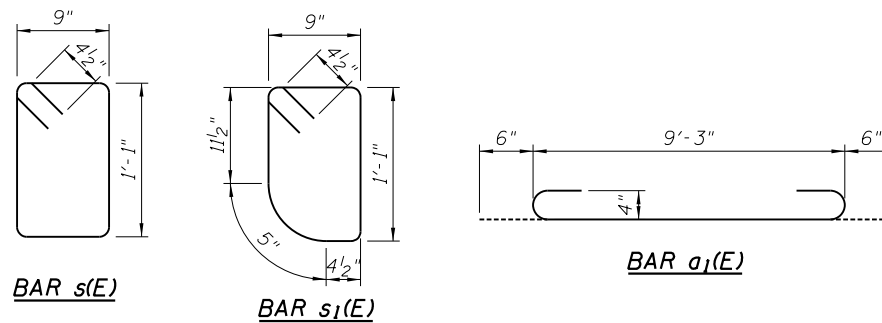

Station 912+26
 Built by
 State of Illinois
 F.A.P. Rte 642 Sec. 104T-3
 Loading HL-93
 Structure No. 043-1098

NAME PLATE
 See Std. 515001-03

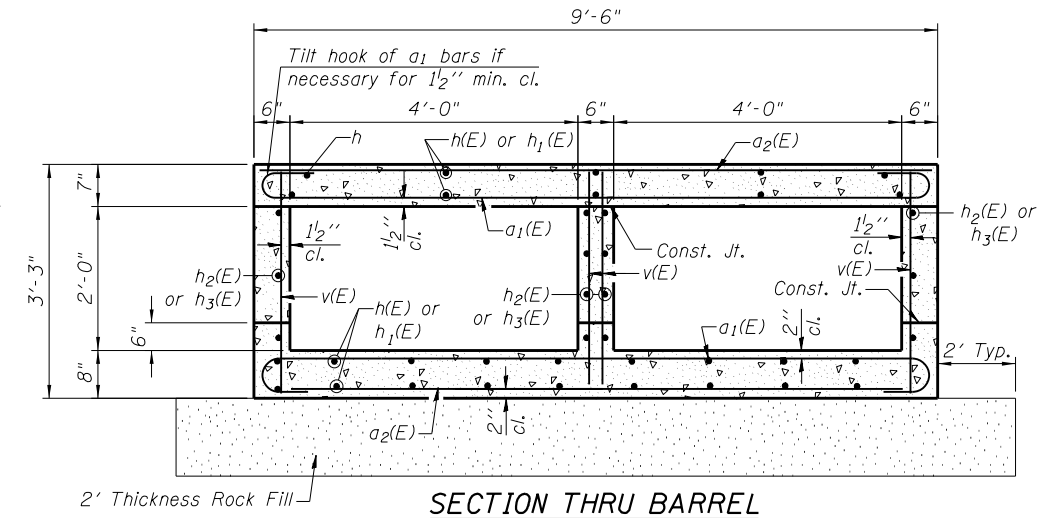

SECTION THRU BARREL

TOTAL BILL OF MATERIAL - STA. 912+26

BAR	NO.	SIZE	LENGTH	SHAPE
a 1 (E)	240	# 4	10' - 3"	U
a 2 (E)	240	# 5	9' - 3"	—
a 3 (E)	41	# 5	10' - 8"	U
a 4 (E)	24	# 4	9' - 8"	—
d (E)	10	# 4	4' - 6"	L
h (E)	40	# 4	34' - 4"	—
h 1 (E)	40	# 4	34' - 4"	—
h 2 (E)	16	# 5	34' - 4"	—
h 3 (E)	16	# 5	34' - 4"	—
h 4 (E)	8	# 6	9' - 8"	—
h 5 (E)	6	# 4	9' - 8"	—
h 6 (E)	6	# 4	8' - 8"	—
h 7 (E)	6	# 5	10' - 9"	—
h 8 (E)	22	# 4	10' - 6"	—
h 9 (E)	22	# 4	16' - 9"	—
h 10 (E)	8	# 4	15' - 9"	—
h 11 (E)	8	# 4	14' - 0"	—
s (E)	11	# 4	4' - 5"	—
s 1 (E)	11	# 4	4' - 4"	—
v (E)	376	# 4	3' - 0"	—
v 1 (E)	38	# 4	5' - 8"	L
v 2 (E)	19	# 4	4' - 8"	—
v 3 (E)	34	# 4	3' - 9"	L
v 4 (E)	17	# 4	2' - 8"	—
ITEM	UNIT	QUANTITY		
Concrete Box Culverts	Cu.Yd.	47.6		
Reinforcement Bars, Epoxy Coated	Pound	9540		
Bar Splicers	Each	56		



USER NAME = rundbladerr	DESIGNED - SB	REVISED -
WES JOB # = 2130199	DRAWN - BEH	REVISED -
PLOT SCALE = 10.0000 "/td> <td>CHECKED - DB</td> <td>REVISED -</td>	CHECKED - DB	REVISED -
PLOT DATE = Thu Oct 10 08:13:48 2013	DATE - 09/13/2013	REVISED -

**STATE OF ILLINOIS
DEPARTMENT OF TRANSPORTATION**

BOX CULVERT DETAILS STA. 912 + 26

SHEET 5 OF 5 SHEETS STA. 912+26

F.A.P. RTE. 642	SECTION 104T-3	COUNTY JO DAVIESS	TOTAL SHEETS 97	SHEET NO. 58
CONTRACT NO. 64F74			ILLINOIS FED. AID PROJECT	