

F.A.P. RTE.	SECTION	COUNTY	TOTAL SHEETS	SHEET NO.
781	1YRS, 2ZRS-1	CRAWFORD	378	101
STA. 13+800		TO STA. 14+150		
FED. ROAD DIST. NO.		ILLINOIS	FED. AID PROJECT	

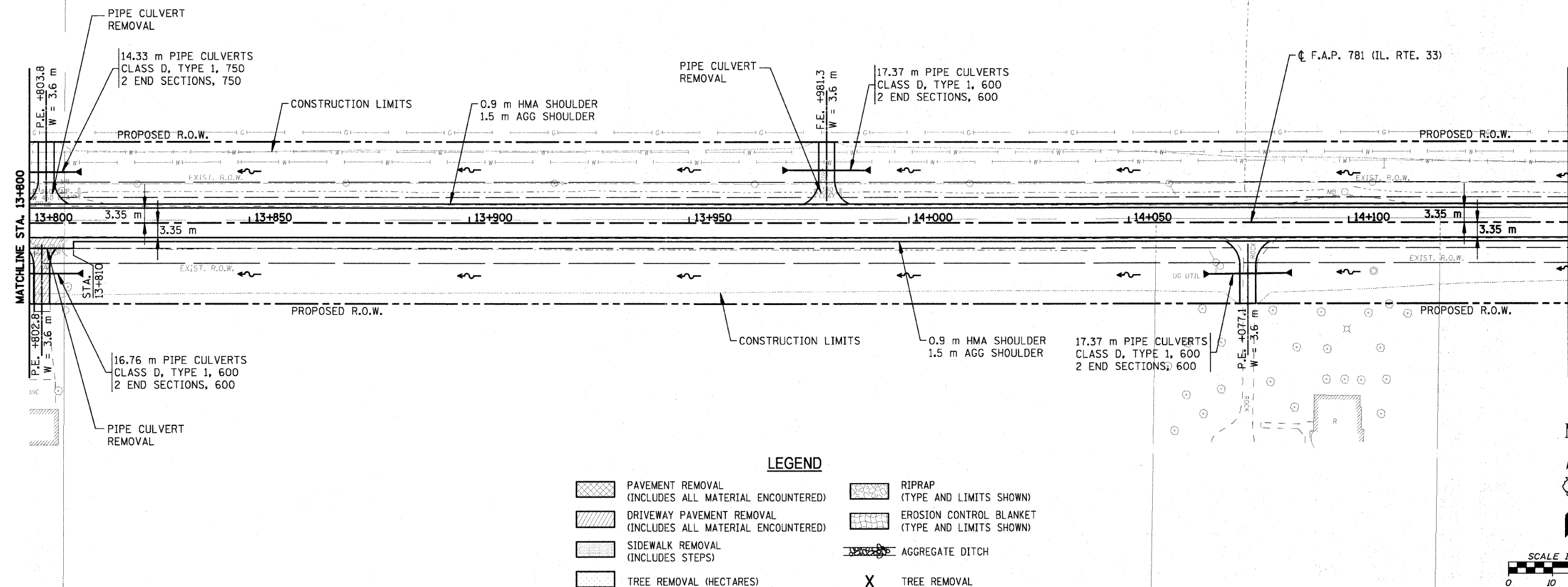

LEGEND

	PAVEMENT REMOVAL (INCLUDES ALL MATERIAL ENCOUNTERED)		RIPRAP (TYPE AND LIMITS SHOWN)
	DRIVEWAY PAVEMENT REMOVAL (INCLUDES ALL MATERIAL ENCOUNTERED)		EROSION CONTROL BLANKET (TYPE AND LIMITS SHOWN)
	SIDEWALK REMOVAL (INCLUDES STEPS)		AGGREGATE DITCH
	TREE REMOVAL (HECTARES)		TREE REMOVAL

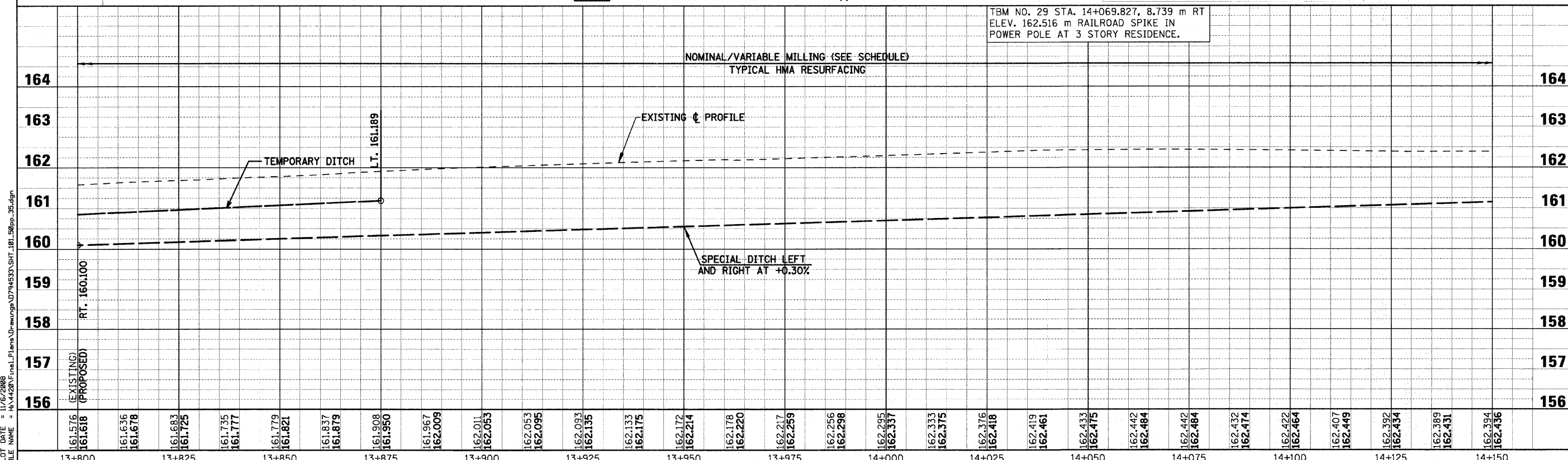

PLOT DATE = 11/16/2008
 FILE NAME = H:\4420\Final\Plana\Drawings\0794533\SH_101_50pp_35.dgn

Sheet: 35
 Angle: 0.8431
 Chain: P_IL33

HMC JOB NO. 4420

F.A.P. RTE.	SECTION	COUNTY	TOTAL SHEETS	SHEET NO.
781	1YRS, 2ZRS-1	CRAWFORD	378	102
STA. 14+150		TO STA. 14+500		
FED. ROAD DIST. NO.	ILLINOIS	FED. AID PROJECT		

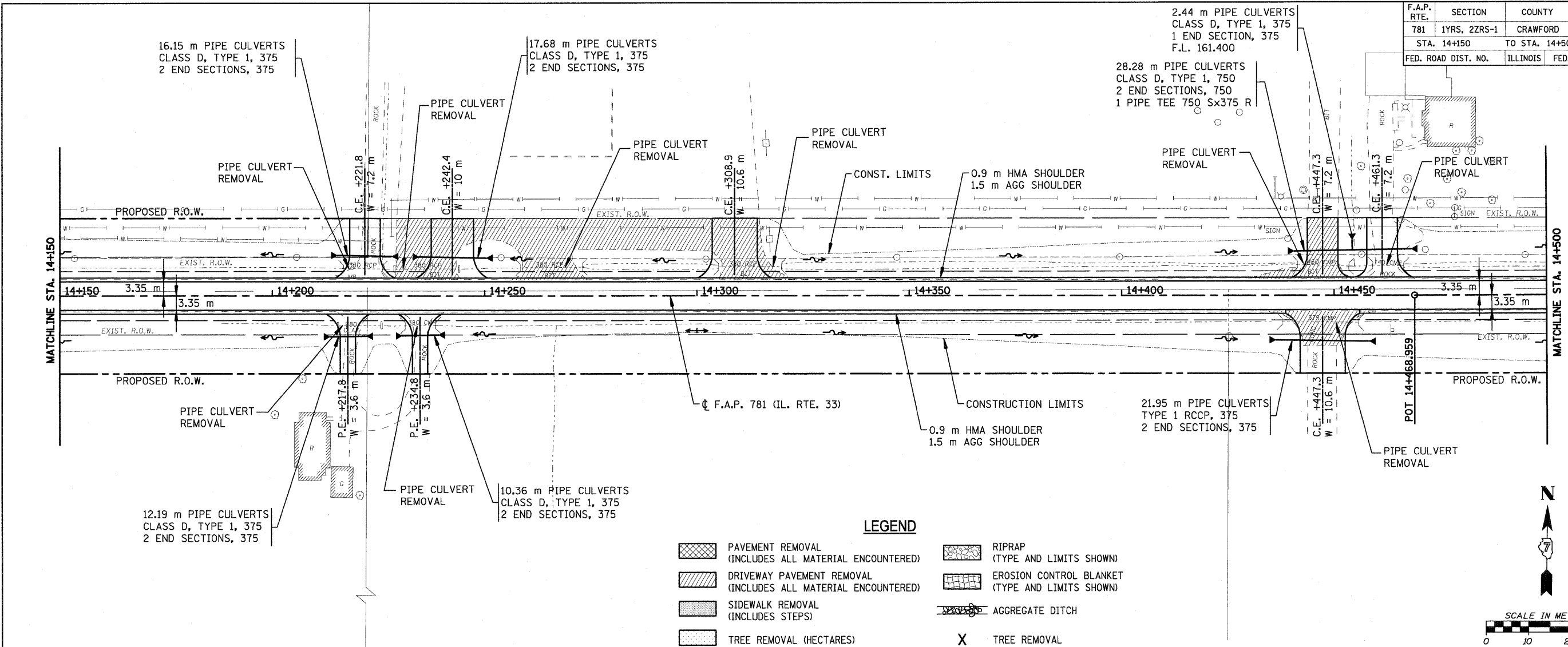

LEGEND

	PAVEMENT REMOVAL (INCLUDES ALL MATERIAL ENCOUNTERED)		RIPRAP (TYPE AND LIMITS SHOWN)
	DRIVEWAY PAVEMENT REMOVAL (INCLUDES ALL MATERIAL ENCOUNTERED)		EROSION CONTROL BLANKET (TYPE AND LIMITS SHOWN)
	SIDEWALK REMOVAL (INCLUDES STEPS)		AGGREGATE DITCH
	TREE REMOVAL (HECTARES)		TREE REMOVAL

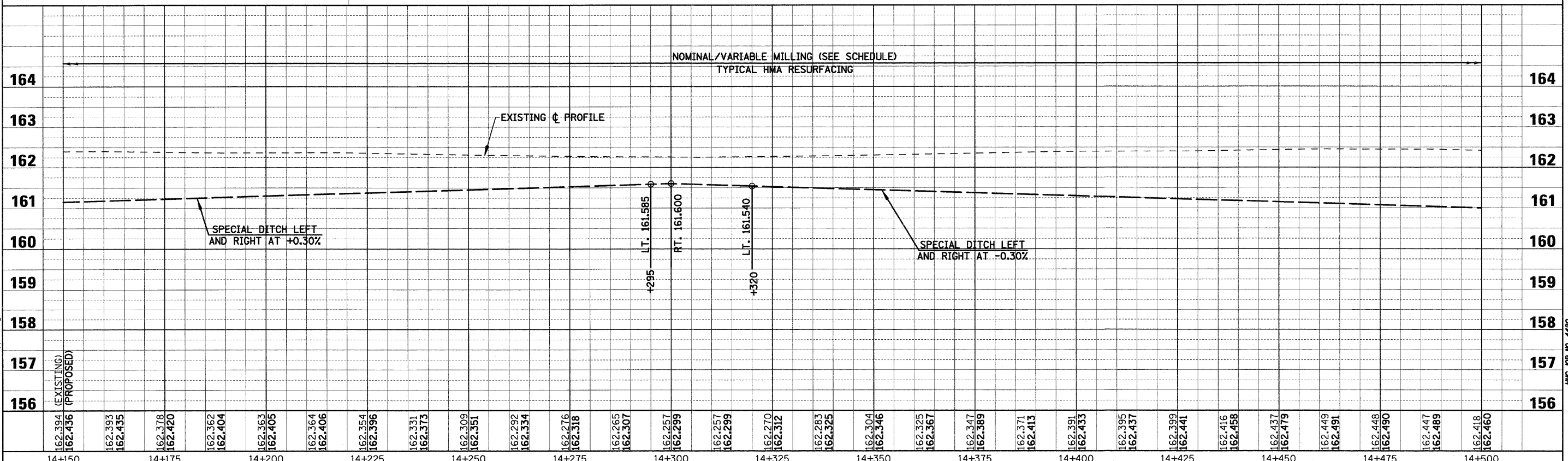
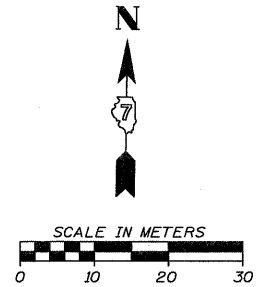

F.A.P. RTE.	SECTION	COUNTY	TOTAL SHEETS	SHEET NO.
781	1YRS, 2ZRS-1	CRAWFORD	378	103
STA. 14+500		TO STA. 14+850		
FED. ROAD DIST. NO.	ILLINOIS	FED. AID PROJECT		

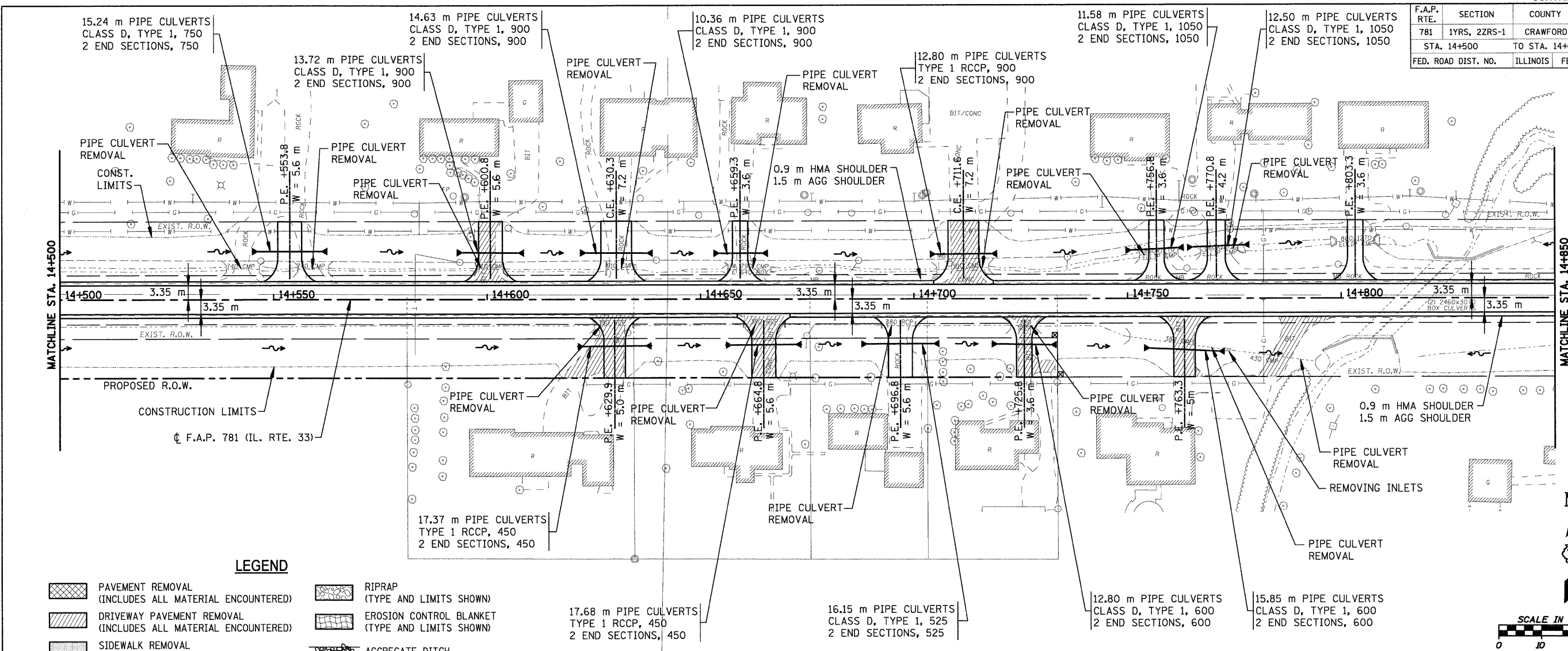

LEGEND

- PAVEMENT REMOVAL (INCLUDES ALL MATERIAL ENCOUNTERED)
- DRIVEWAY PAVEMENT REMOVAL (INCLUDES ALL MATERIAL ENCOUNTERED)
- SIDEWALK REMOVAL (INCLUDES STEPS)
- TREE REMOVAL (HECTARES)
- RIPRAP (TYPE AND LIMITS SHOWN)
- EROSION CONTROL BLANKET (TYPE AND LIMITS SHOWN)
- AGGREGATE DITCH
- TREE REMOVAL

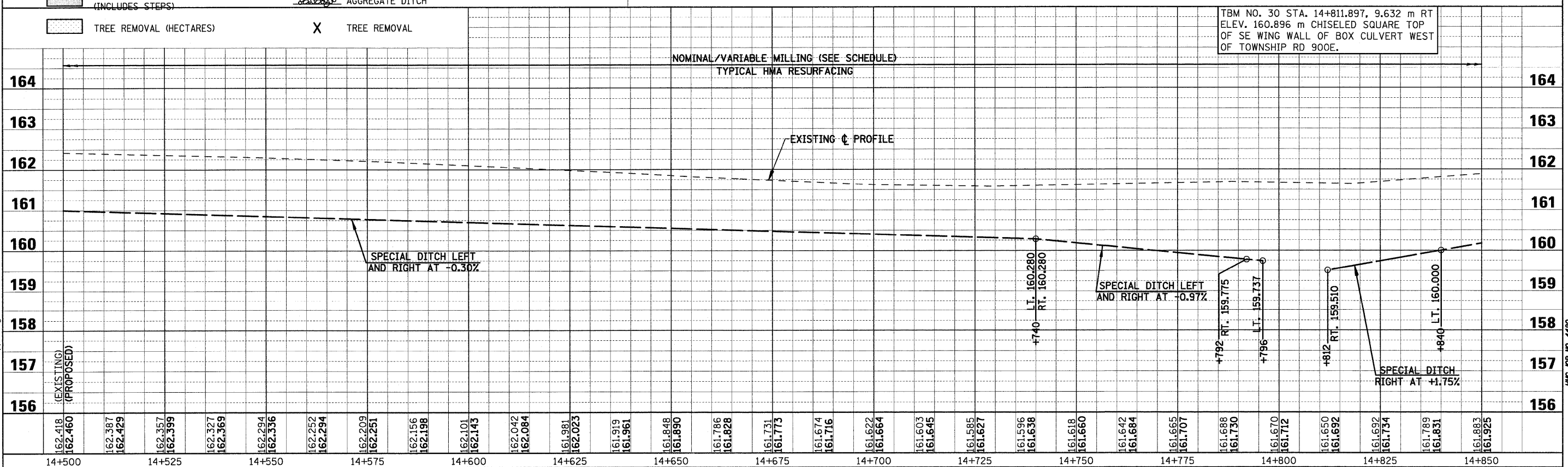

PLOT DATE = 4/16/2008
FILE NAME = H:\1428\781\02_50pp_37.dgn

F.A.P. RTE.	SECTION	COUNTY	TOTAL SHEETS	SHEET NO.
781	1YRS, 2ZRS-1	CRAWFORD	378	104
STA. 14+850		TO STA. 15+200		
FED. ROAD DIST. NO.	ILLINOIS	FED. AID PROJECT		

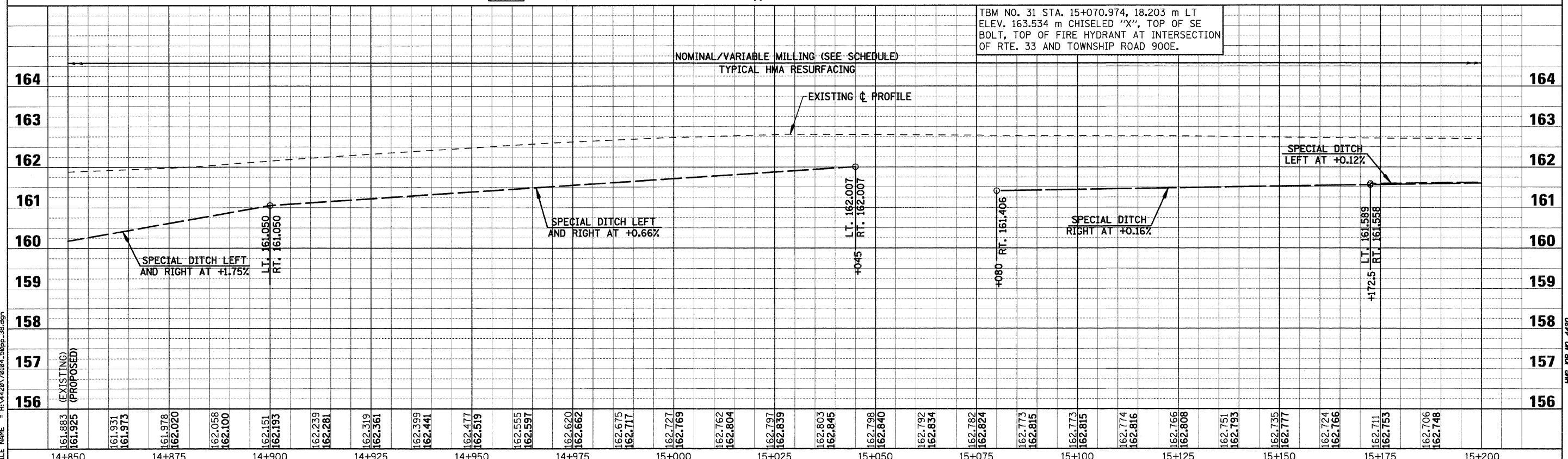
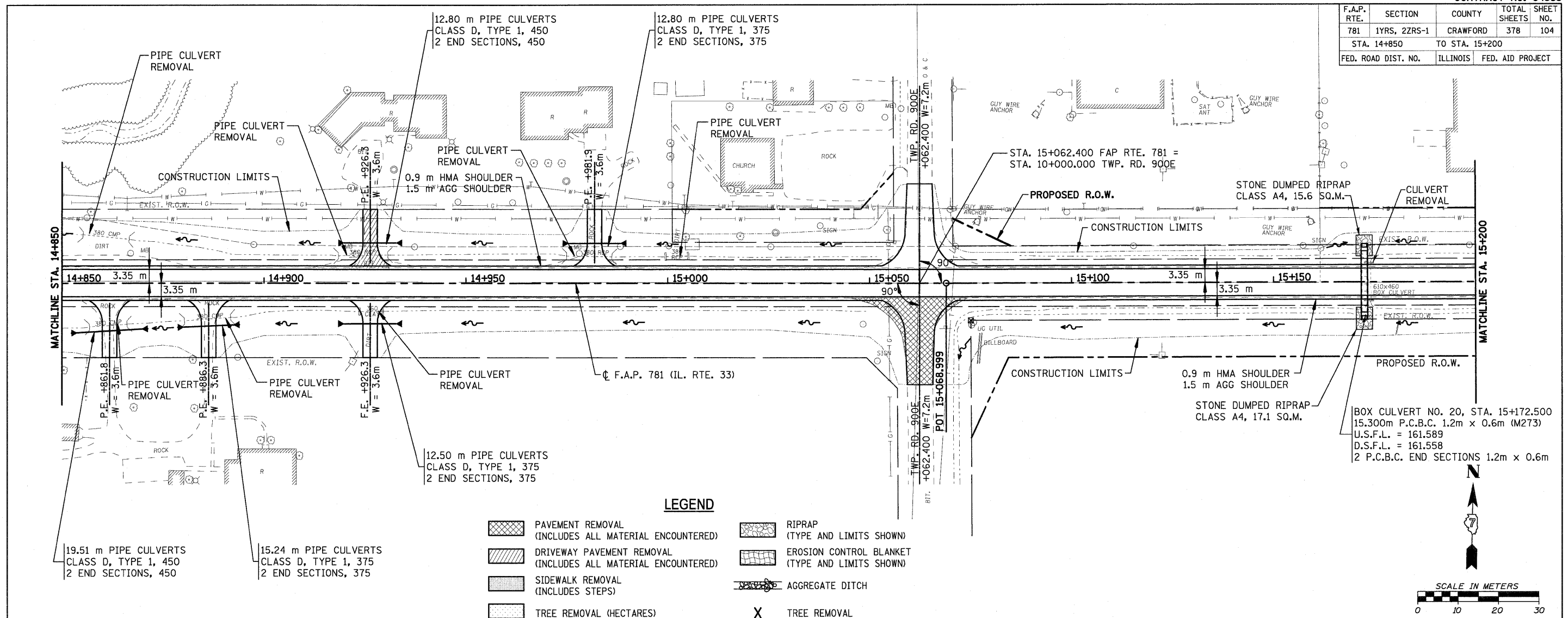

Sheet: 38
 Angle: 1:1000
 Chain: P 1133

PLOT DATE = 4/19/2009
 FILE NAME = H:\4428\781\94533.dgn

HMG JOB NO. 4420

F.A.P. RTE.	SECTION	COUNTY	TOTAL SHEETS	SHEET NO.
781	1YRS, 2ZRS-1	CRAWFORD	378	105
STA. 15+200		TO STA. 15+550		
FED. ROAD DIST. NO.		ILLINOIS	FED. AID PROJECT	

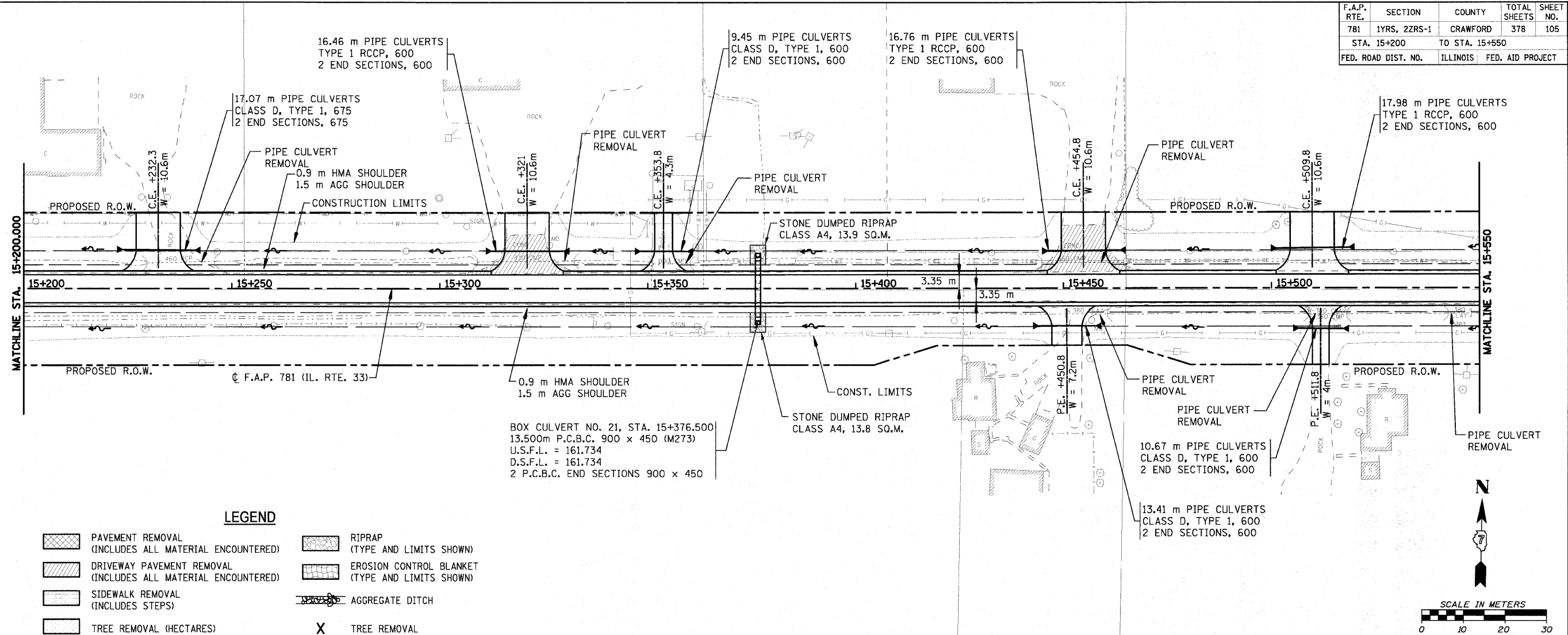

LEGEND

- PAVEMENT REMOVAL (INCLUDES ALL MATERIAL ENCOUNTERED)
- DRIVEWAY PAVEMENT REMOVAL (INCLUDES ALL MATERIAL ENCOUNTERED)
- SIDEWALK REMOVAL (INCLUDES STEPS)
- TREE REMOVAL (HECTARES)
- RIPRAP (TYPE AND LIMITS SHOWN)
- EROSION CONTROL BLANKET (TYPE AND LIMITS SHOWN)
- AGGREGATE DITCH
- TREE REMOVAL

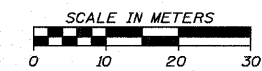

TBM NO. 32 STA. 15+338.225, 8.543 m LT
 ELEV. 162.913 m RAILROAD SPIKE IN
 POWER POLE AT SUPERIOR WELDING SHOP.

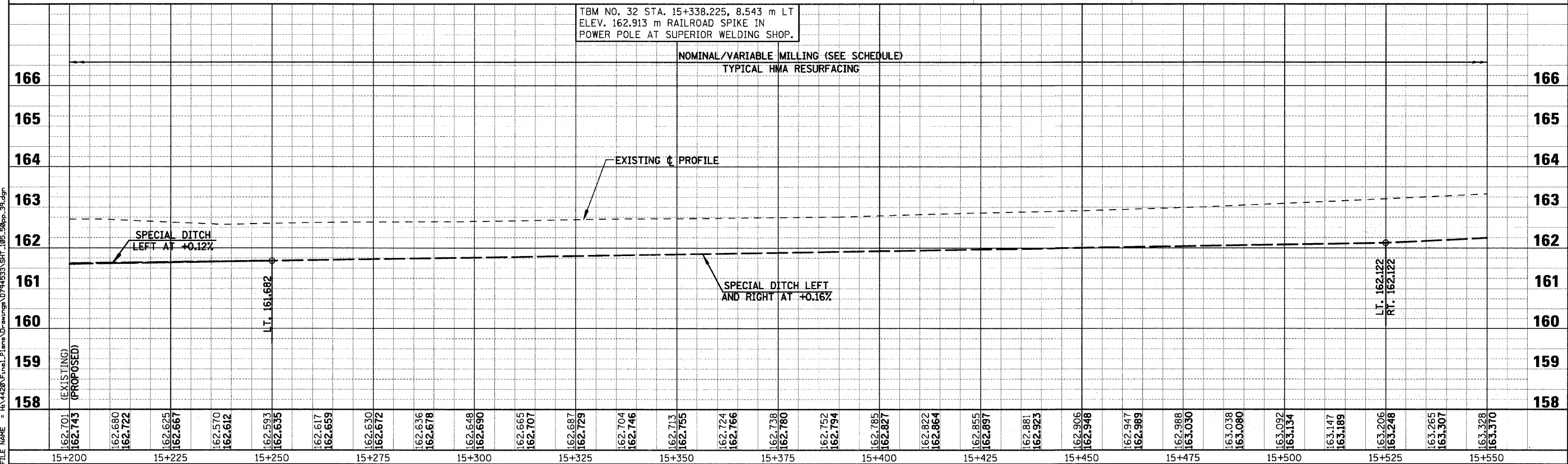

PLOT DATE = 10/28/2008
 FILE NAME = H:\4420\Final\Plans\Drawings\074533\SH1_105_50pp_39.dgn

F.A.P. RTE.	SECTION	COUNTY	TOTAL SHEETS	SHEET NO.
781	1YRS, 2ZRS-1	CRAWFORD	378	106
STA. 15+550 TO STA. 15+900				
FED. ROAD DIST. NO.	ILLINOIS	FED. AID PROJECT		

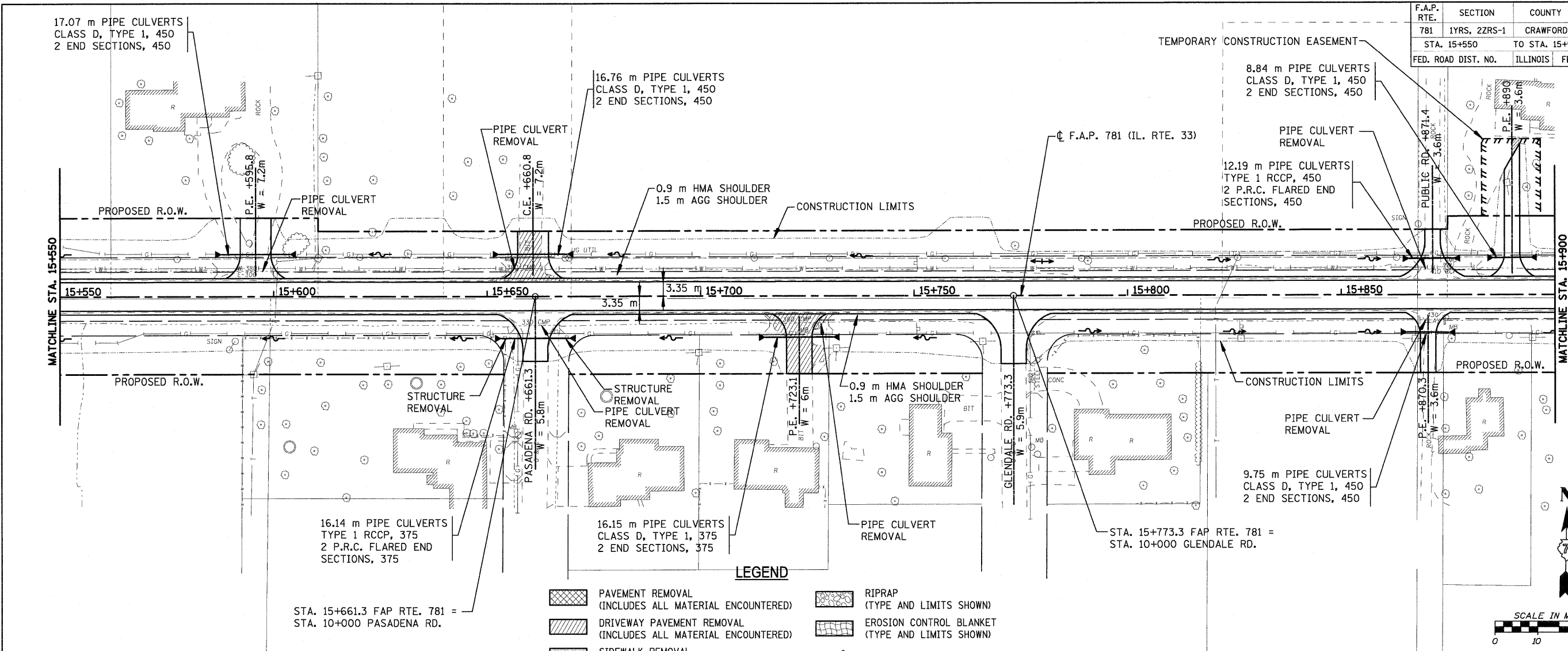

- LEGEND**
- PAVEMENT REMOVAL (INCLUDES ALL MATERIAL ENCOUNTERED)
 - DRIVEWAY PAVEMENT REMOVAL (INCLUDES ALL MATERIAL ENCOUNTERED)
 - SIDEWALK REMOVAL (INCLUDES STEPS)
 - TREE REMOVAL (HECTARES)
 - RIPRAP (TYPE AND LIMITS SHOWN)
 - EROSION CONTROL BLANKET (TYPE AND LIMITS SHOWN)
 - AGGREGATE DITCH
 - TREE REMOVAL

TBM NO. 33 STA. 15+778.807, 14.901 m RT
 ELEV. 165.270 m CHISELED "X", TOP OF NORTH BOLT, TOP OF FIRE HYDRANT AT INTERSECTION OF RTE. 33 AND GLENDALE STREET IN ROBINSON.

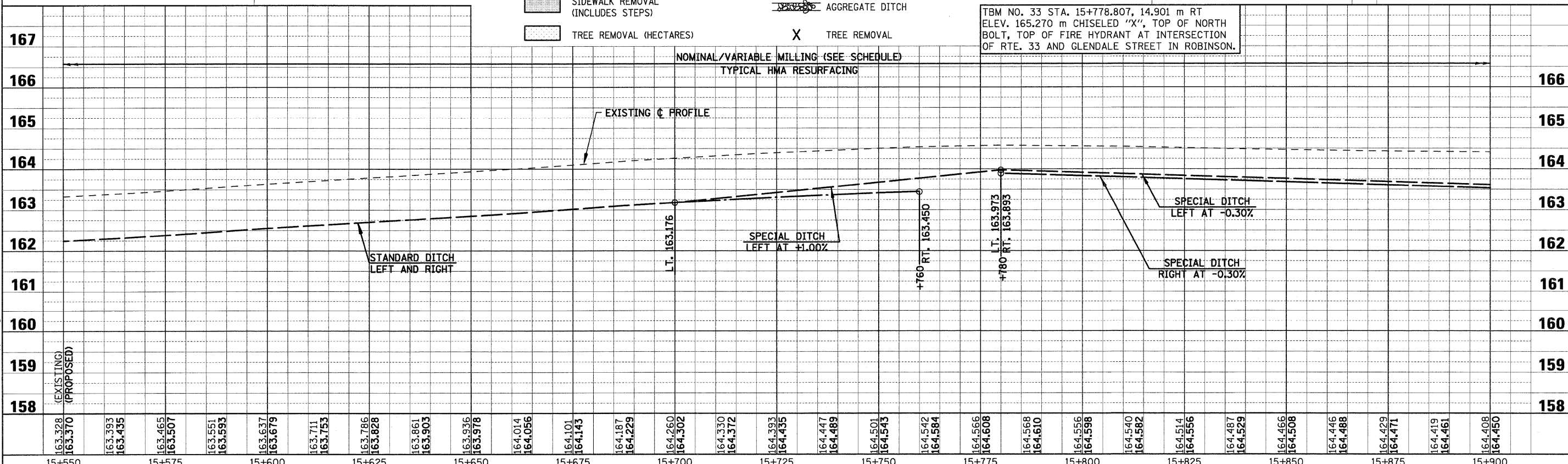

F.A.P. RTE.	SECTION	COUNTY	TOTAL SHEETS	SHEET NO.
781	1YRS, 2ZRS-1	CRAWFORD	378	107
STA. 15+900		TO STA. 16+016		
FED. ROAD DIST. NO.	ILLINOIS	FED. AID PROJECT		

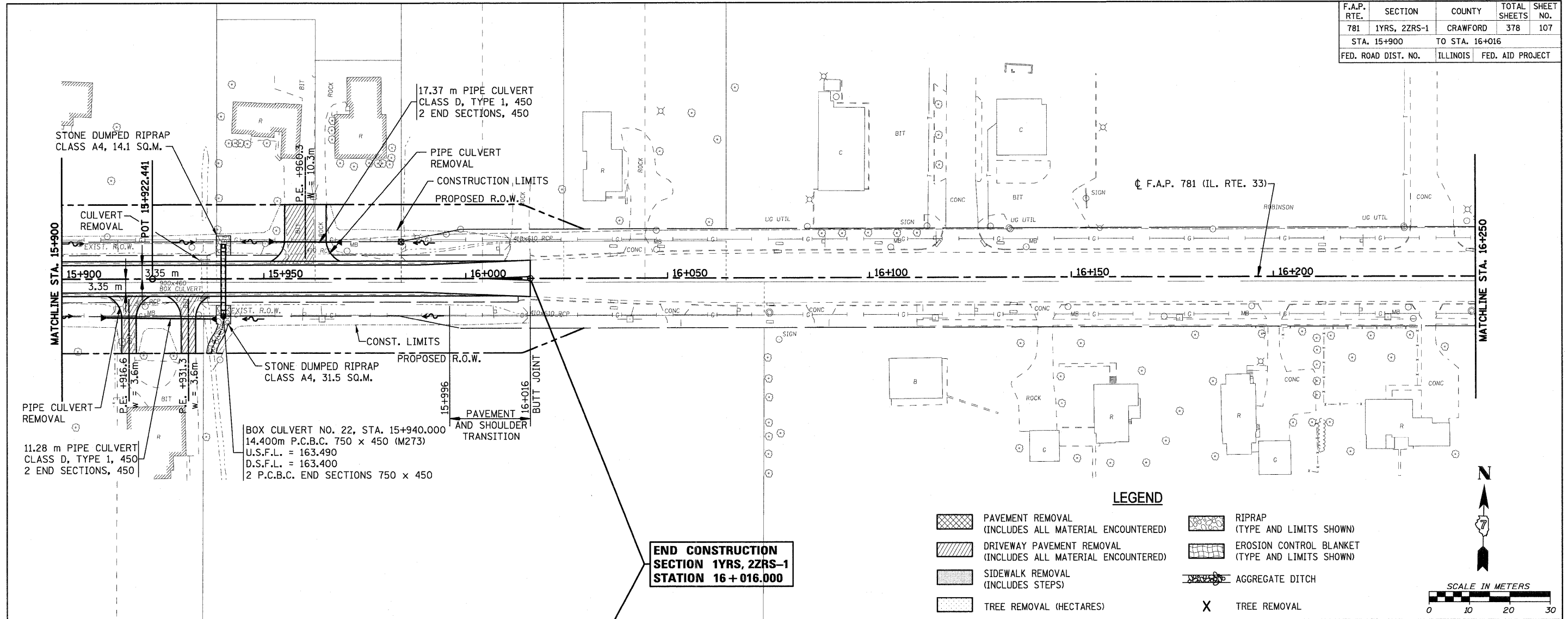

**END CONSTRUCTION
SECTION 1YRS, 2ZRS-1
STATION 16 + 016.000**

LEGEND

- PAVEMENT REMOVAL (INCLUDES ALL MATERIAL ENCOUNTERED)
- DRIVEWAY PAVEMENT REMOVAL (INCLUDES ALL MATERIAL ENCOUNTERED)
- SIDEWALK REMOVAL (INCLUDES STEPS)
- TREE REMOVAL (HECTARES)
- RIPRAP (TYPE AND LIMITS SHOWN)
- EROSION CONTROL BLANKET (TYPE AND LIMITS SHOWN)
- AGGREGATE DITCH
- TREE REMOVAL

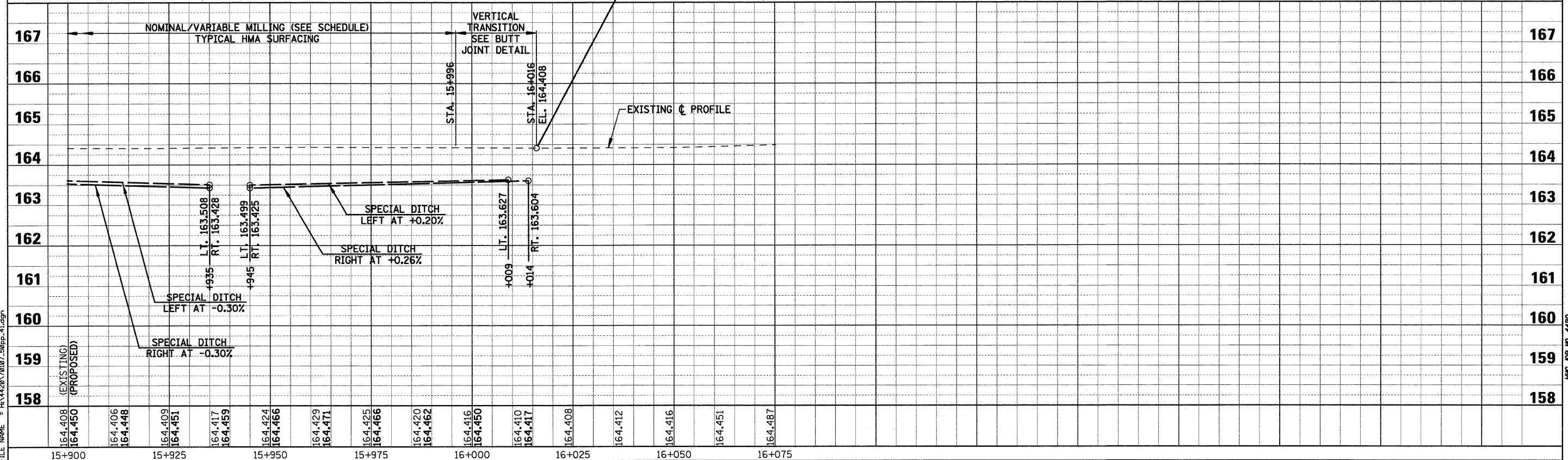
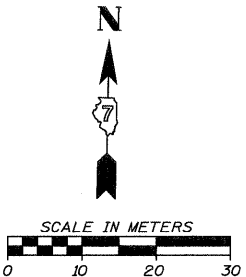

PLOT DATE = 4/18/2008
FILE NAME = H:\1428\70107_50pp_41.dgn

F.A.P. RTE.	SECTION	COUNTY	TOTAL SHEETS	SHEET NO.
781	1YRS, 2ZRS-1	CRAWFORD	378	108
STA.		TO STA.		
FED. ROAD DIST. NO.		ILLINOIS	FED. AID PROJECT	

BASE LEVELING PAD NOTES

1. THE LEVELING PAD IS TO BE CONSTRUCTED OF CRUSHED AGGREGATE OR 2,000 PSI UNREINFORCED CONCRETE
2. THE BASE FOUNDATION IS TO BE APPROVED BY THE SITE GEOTECHNICAL ENGINEER PRIOR TO PLACEMENT OF THE LEVELING PAD.

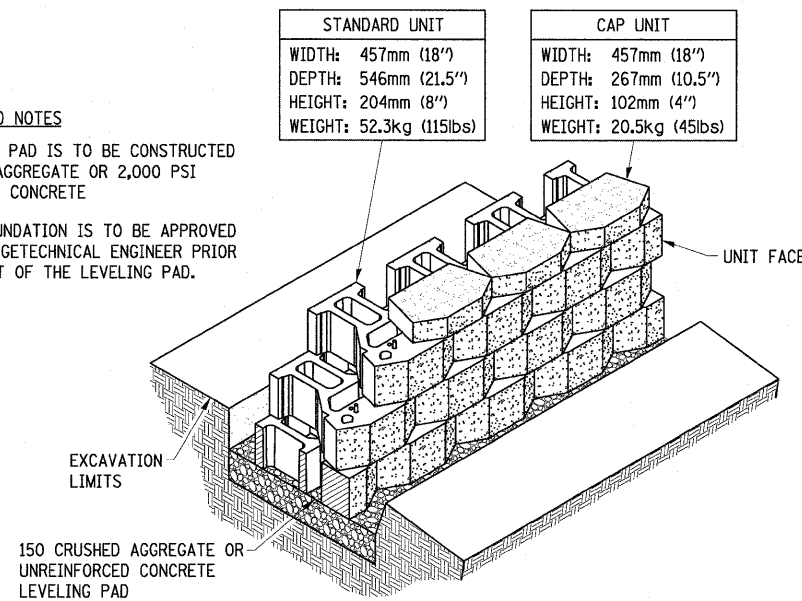

STANDARD UNIT/BASE PAD ISOMETRIC SECTION VIEW

Unit Dimensions & Weight May Vary by Region

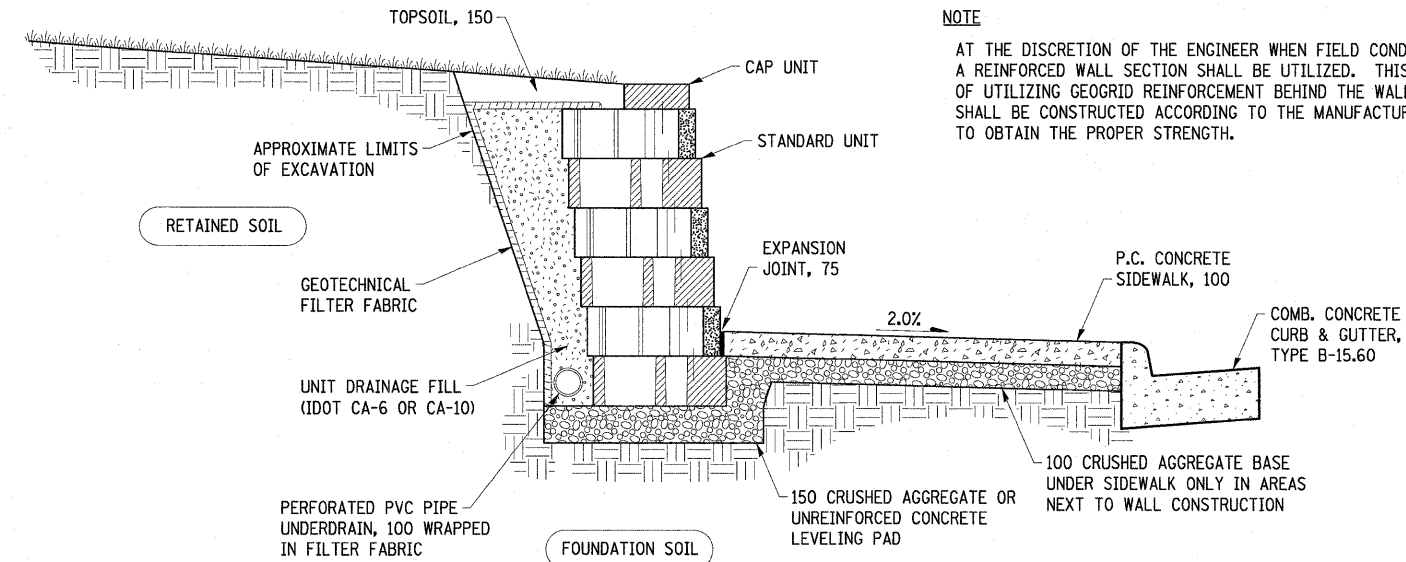

NOTE

AT THE DISCRETION OF THE ENGINEER WHEN FIELD CONDITIONS WARRANT, A REINFORCED WALL SECTION SHALL BE UTILIZED. THIS SHALL CONSIST OF UTILIZING GEOGRID REINFORCEMENT BEHIND THE WALL. THE GEOGRID SHALL BE CONSTRUCTED ACCORDING TO THE MANUFACTURERS SPECIFICATIONS TO OBTAIN THE PROPER STRENGTH.

TYPICAL GRAVITY WALL SECTION

Standard Unit - 25mm (1") Setback

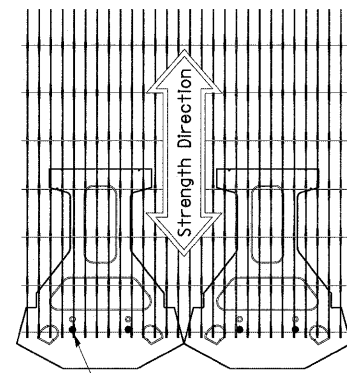

GRID & PIN CONNECTION

If Required Due to Soil Conditions

GEOGRID IS TO BE PLACED ON LEVEL BACKFILL AND EXTENDED OVER THE FIBERGLASS PINS. PLACE NEXT UNIT. PULL GRID TAUGHT AND BACKFILL. STAKE AS REQUIRED

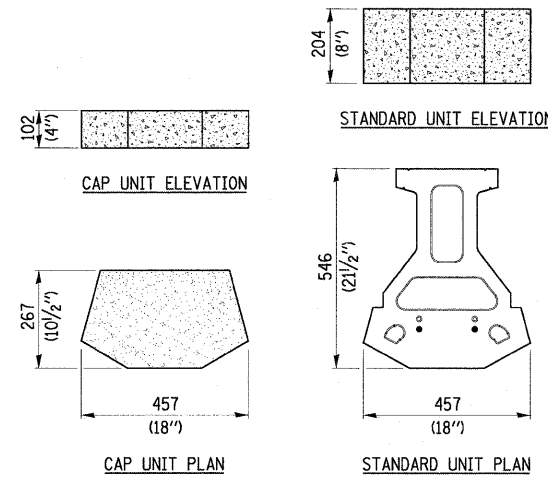

STANDARD TRI-PLANE UNIT/CAP DETAILS

Unit Dimensions & Weight May Vary by Region

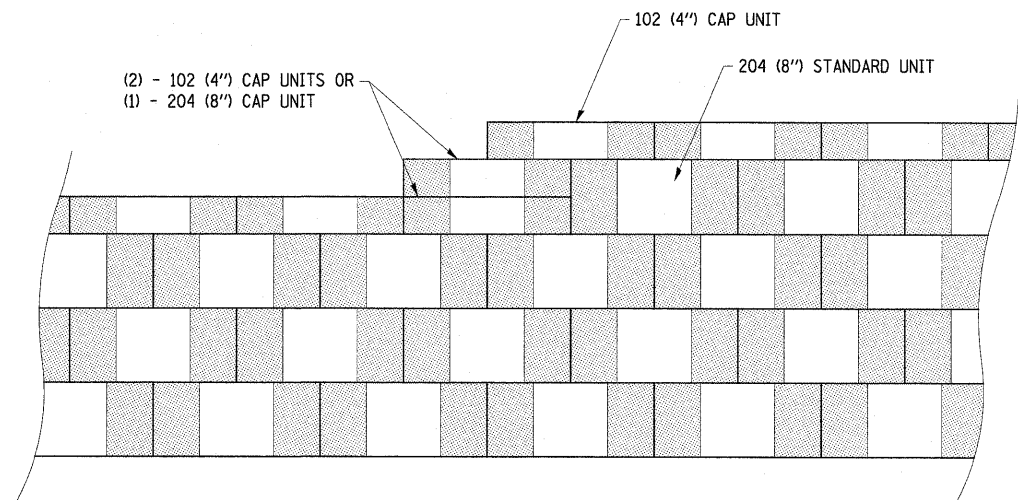

TOP OF WALL STEP DETAIL

Unit Dimensions & Weight May Vary by Region

ALL DIMENSIONS ARE IN MILLIMETERS UNLESS OTHERWISE SHOWN.

REVISIONS		ILLINOIS DEPARTMENT OF TRANSPORTATION
NAME	DATE	
		SEGMENTAL CONCRETE BLOCK WALL SCALE NO SCALE DATE APRIL 18, 2008

DRAWN BY EDW
CHECKED BY RGH

F.A.P. RTE.	SECTION	COUNTY	TOTAL SHEETS	SHEET NO.
781	1YRS, 2ZRS-1	CRAWFORD	378	109
STA.		TO STA.		
FED. ROAD DIST. NO.		ILLINOIS	FED. AID PROJECT	

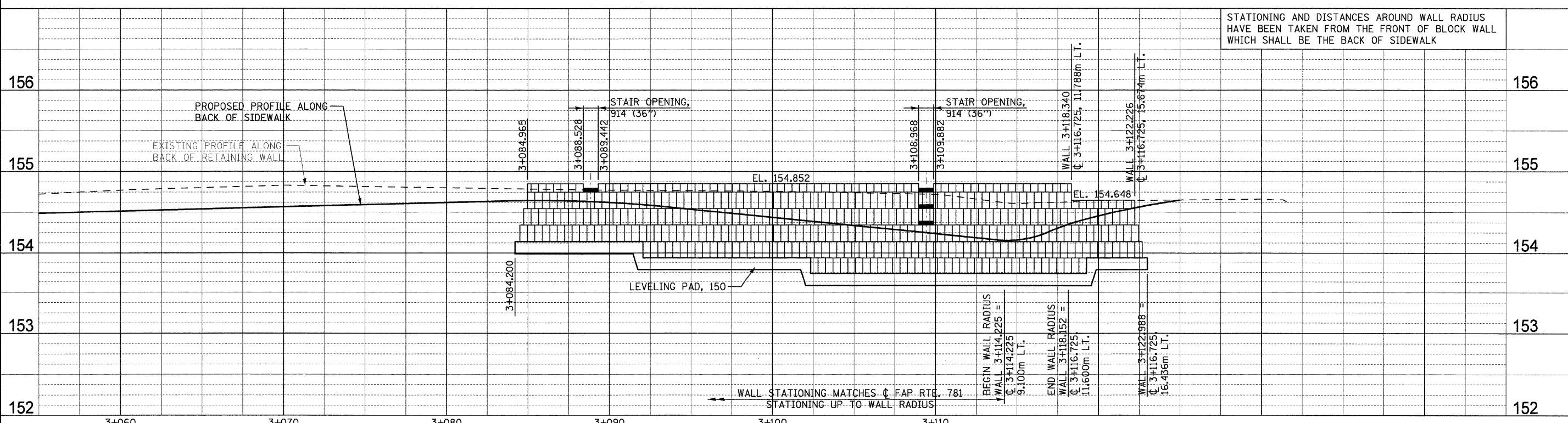
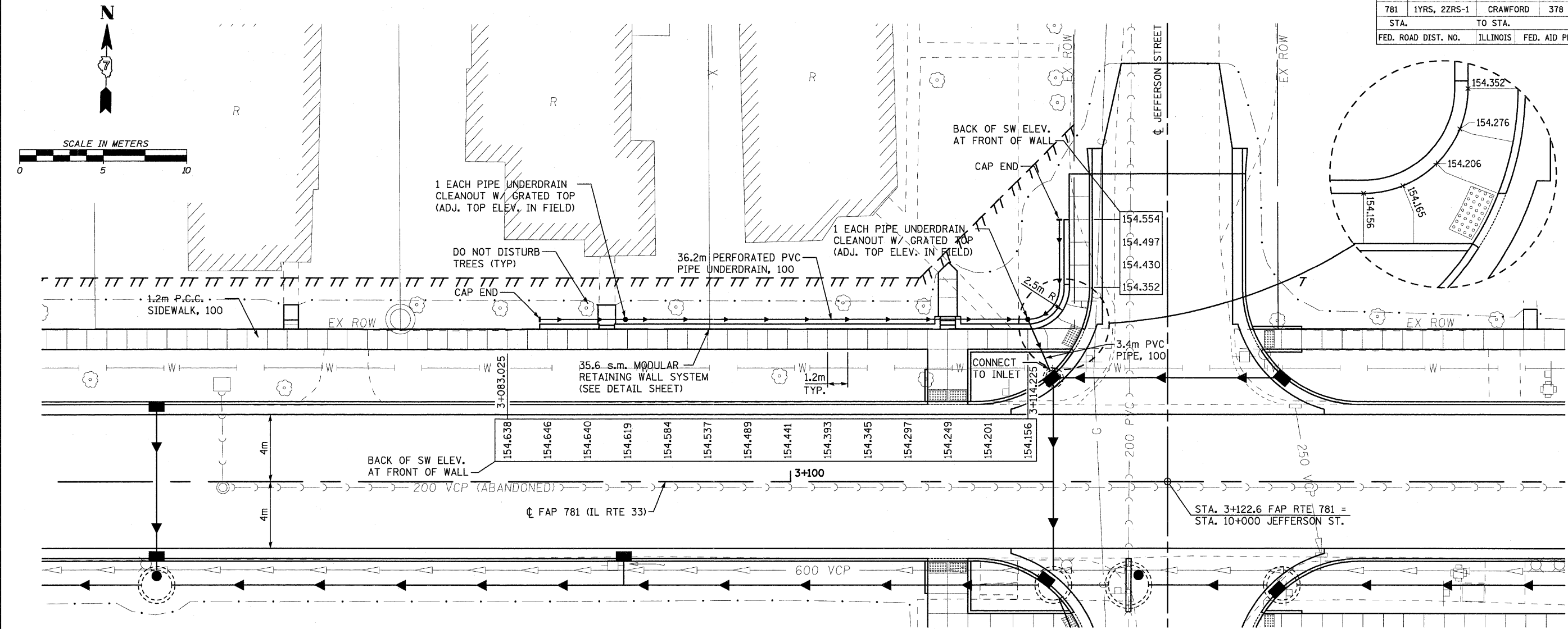

PLOT DATE = 4/18/2008
 FILE NAME = HA\428\70109_modwall_pp.dgn

HMG JOB NO. 4420

F.A.P. RTE.	SECTION	COUNTY	TOTAL SHEETS	SHEET NO.
781	1YRS, 2ZRS-1	CRAWFORD	378	110
STA. TO STA.				
FED. ROAD DIST. NO.		ILLINOIS	FED. AID PROJECT	

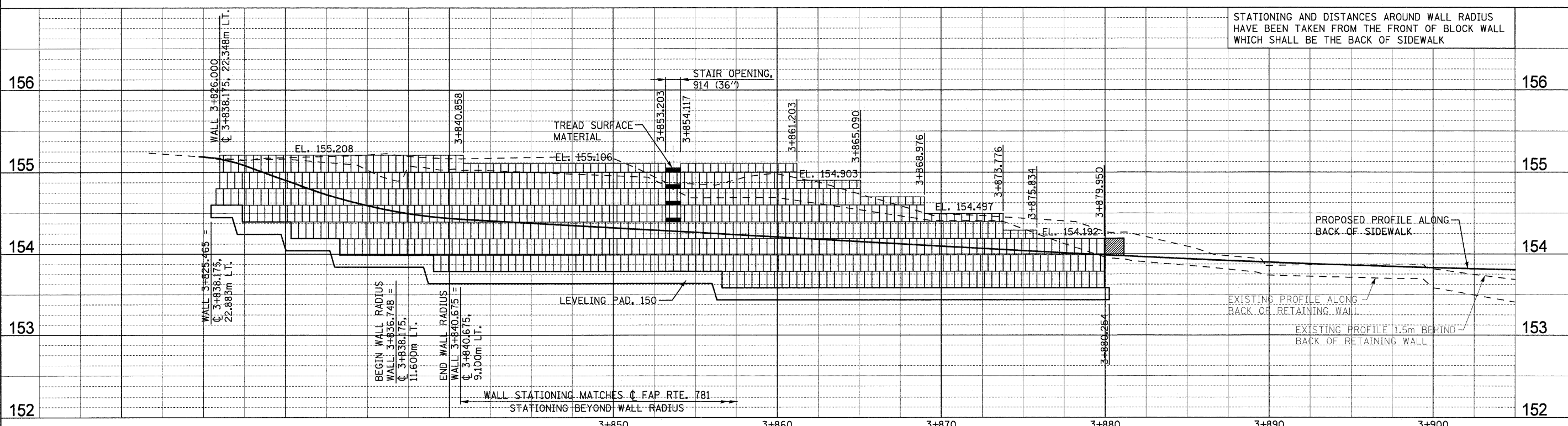
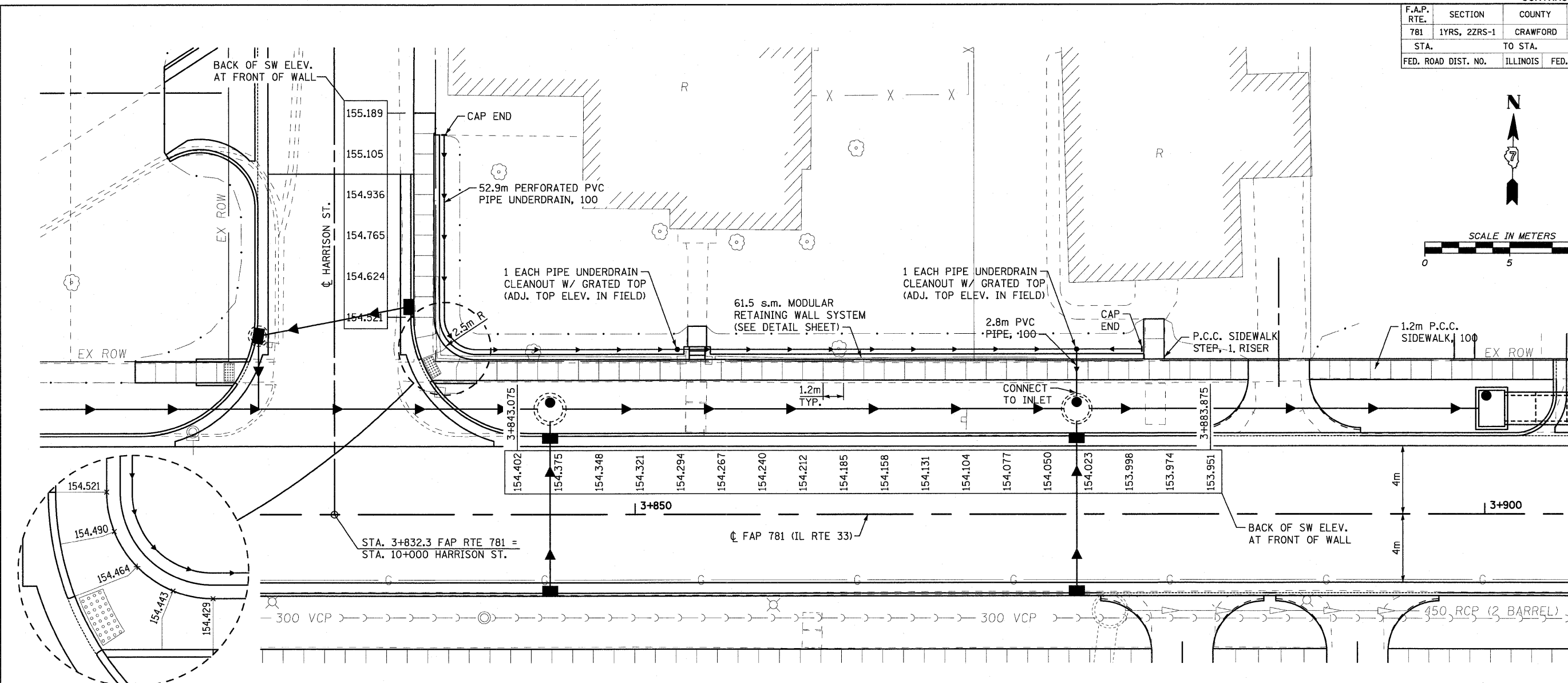
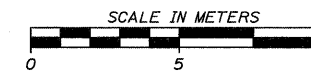

PLOT DATE = 4/19/2008
FILE NAME = H:\4420\78108_mohall_pp_02.dgn

HMG JOB NO. 4420

F.A.P. RTE.	SECTION	COUNTY	TOTAL SHEETS	SHEET NO.
781	1YRS, 2ZRS-1	CRAWFORD	378	111
STA.	TO STA.			
FED. ROAD DIST. NO.	ILLINOIS	FED. AID PROJECT		

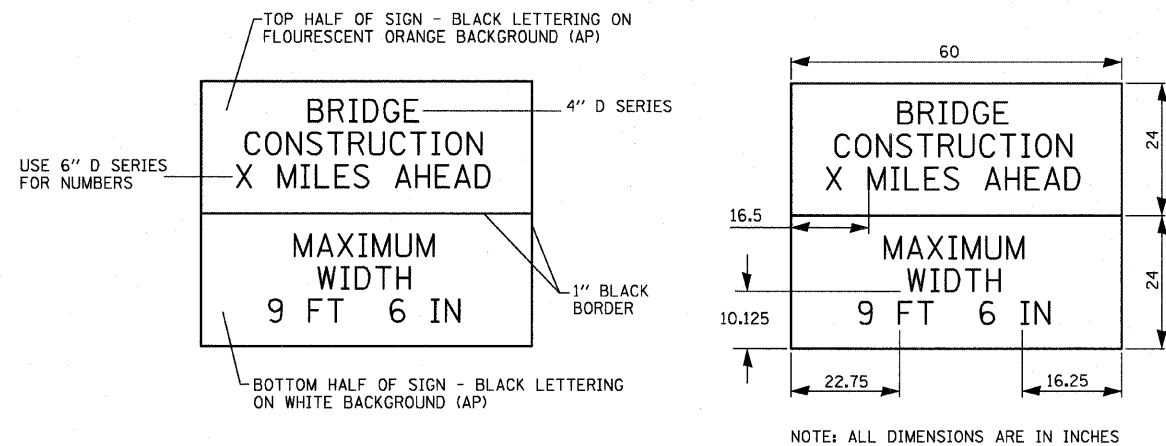

WIDTH RESTRICTION SIGN

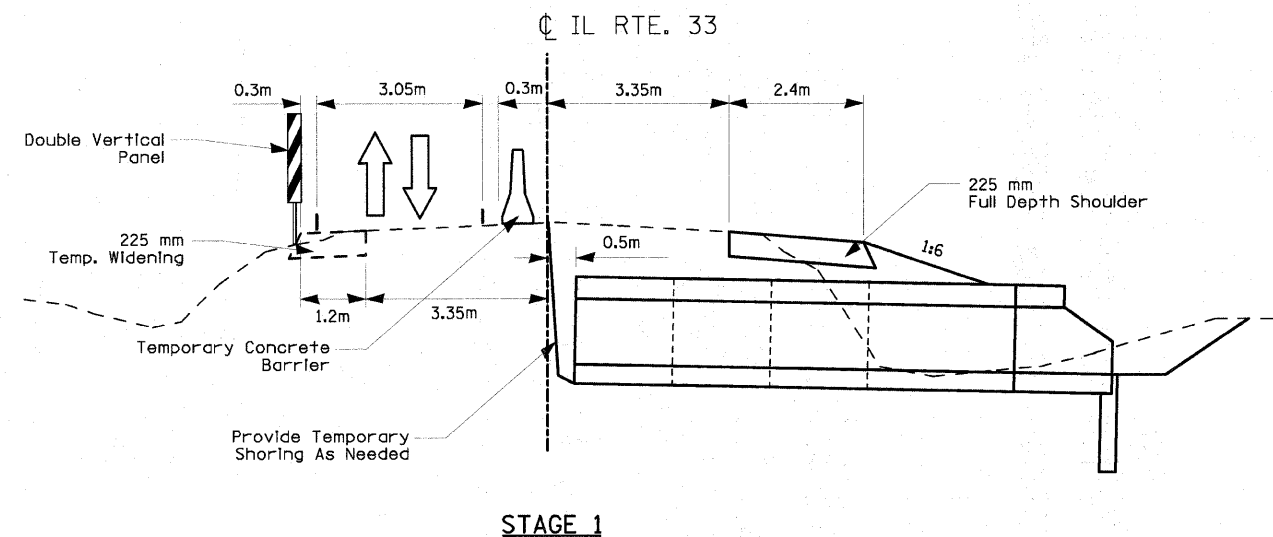

STAGE 1

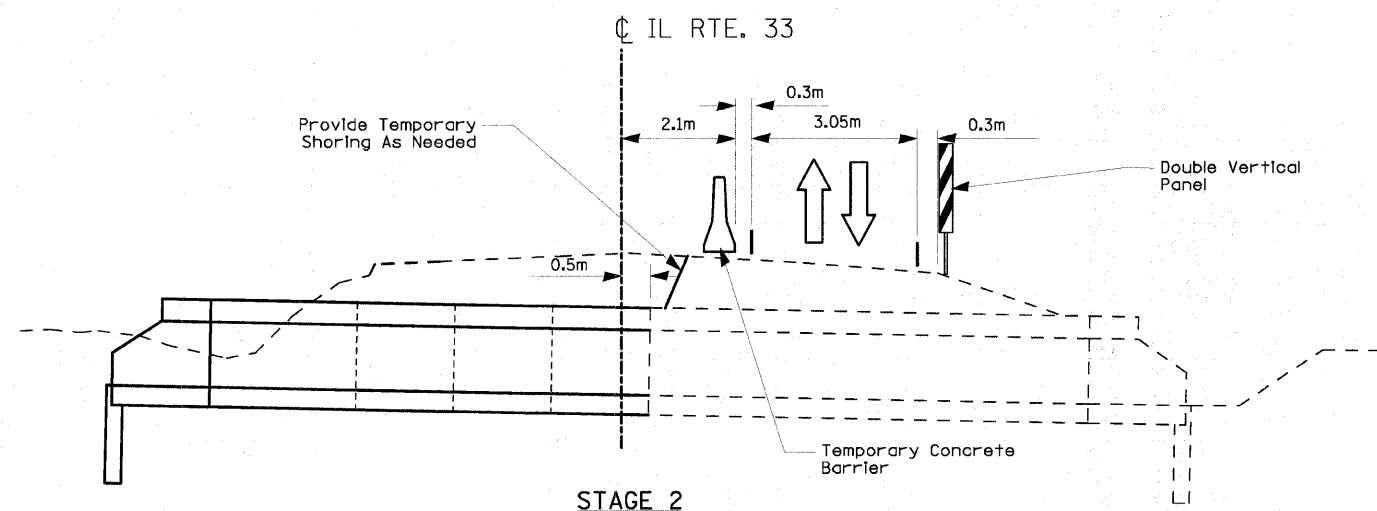

STAGE 2

TRAFFIC CONTROL NOTES:

THE CONTRACTOR SHALL UTILIZE TRAFFIC CONTROL STANDARD 701321 DURING EXECUTION OF THIS WORK. TEMPORARY BRIDGE TRAFFIC SIGNALS, TEMPORARY RUMBLE STRIPS, TEMPORARY CONCRETE BARRIER, AND IMPACT ATTENUATORS SHALL BE PAID FOR AT THE CONTRACT UNIT PRICE FOR SAID ITEMS, ALL OTHER STRIPING, STRIPING REMOVAL, SIGNAGE, ETC. REQUIRED BY THE STANDARD SHALL BE INCLUDED IN THE CONTRACT UNIT PRICE PER EACH FOR TRAFFIC CONTROL AND PROTECTION, STANDARD 701321 (SPECIAL) ONCE FOR EACH CULVERT LOCATION. NO ADDITIONAL COMPENSATION WILL BE ALLOWED FOR ANY CHANGES OR ADJUSTMENTS TO THE TRAFFIC CONTROL DURING THE CONVERSION TO STAGE 2 OF THE WORK.

THE CONTRACTOR SHALL SUPPLY, SET, AND MAINTAIN TWO (2) WIDTH RESTRICTION WARNING SIGNS, AS SHOWN IN THE DETAIL, PRIOR TO COMMENCING WORK UNLESS THEY ARE ALREADY IN PLACE FOR OTHER ITEMS OF WORK. THE SIGNS SHALL BE PLACED AT THE INTERSECTIONS OF IL 33 AND IL 49 AND IL 33 AND IL 1, OR OTHER LOCATION, AS DIRECTED BY THE ENGINEER.

ALL LABOR AND MATERIALS REQUIRED TO SUPPLY, SET, AND MAINTAIN THESE SIGNS WILL NOT BE PAID FOR SEPARATELY, BUT SHALL BE INCLUDED IN THE CONTRACT UNIT PRICE PER EACH FOR TRAFFIC CONTROL AND PROTECTION, STANDARD 701321 (SPECIAL).

DOUBLE VERTICAL PANELS, AS SHOWN IN THE DETAIL, SHALL BE USED IF GUARDRAIL IS NOT PRESENT. ALL LABOR AND MATERIALS REQUIRED TO SUPPLY, SET, AND MAINTAIN THE PANELS WILL NOT BE PAID FOR SEPARATELY, BUT SHALL BE INCLUDED IN THE CONTRACT UNIT PRICE PER EACH FOR TRAFFIC CONTROL AND PROTECTION, STANDARD 701321 (SPECIAL).

THE CONTRACT QUANTITIES INCLUDE 100 METERS OF TEMPORARY CONCRETE BARRIER AND TWO (2) IMPACT ATTENUATORS FOR EACH CULVERT LOCATION.

REVISIONS		ILLINOIS DEPARTMENT OF TRANSPORTATION CULVERT REPLACEMENT AND INSTALLATION
NAME	DATE	
		STAGING PLAN SCALE NO SCALE DRAWN BY EDW DATE OCTOBER 28, 2008 CHECKED BY LWJ

PLOT DATE = 11/6/2008
 FILE NAME = H:\4420\Final_Plans\Drawings\0794533\SH1_IL1_rural_culvert_staging.dgn

H. M. & G. NO. 4420

F.A.P. RTE.	SECTION	COUNTY	TOTAL SHEETS	SHEET NO.
781	1YRS, 2ZRS-1	CRAWFORD	378	112
STA. TO STA.				
FED. ROAD DIST. NO.		ILLINOIS	FED. AID PROJECT	

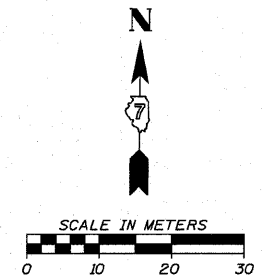

LEGEND

- CONSTRUCTION THIS STAGE
- TEMPORARY PAVEMENT

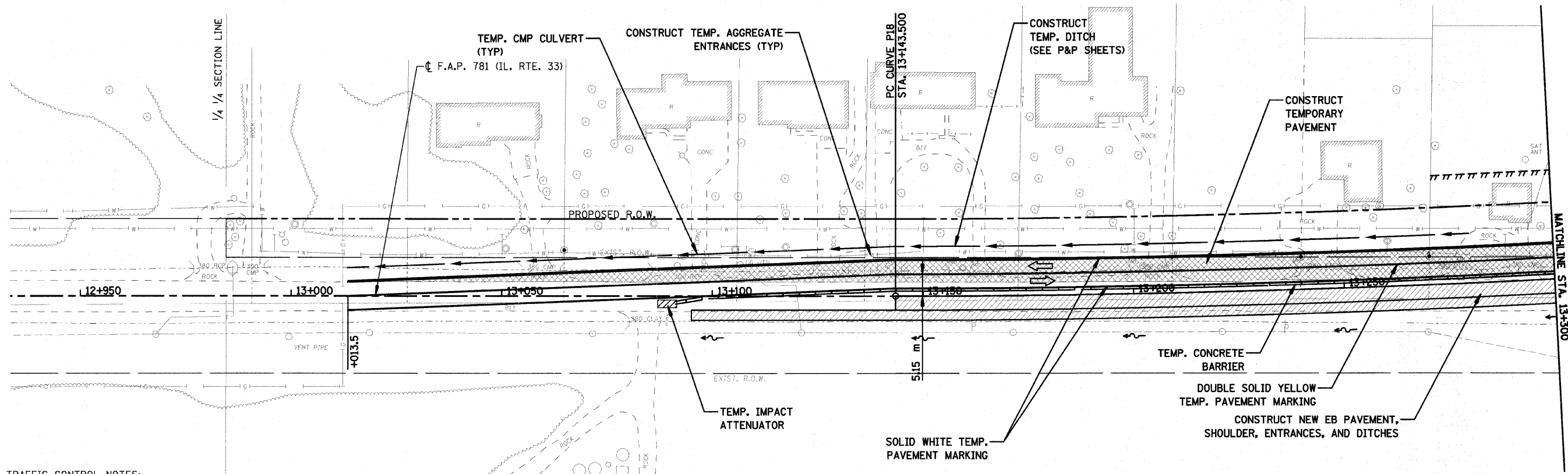
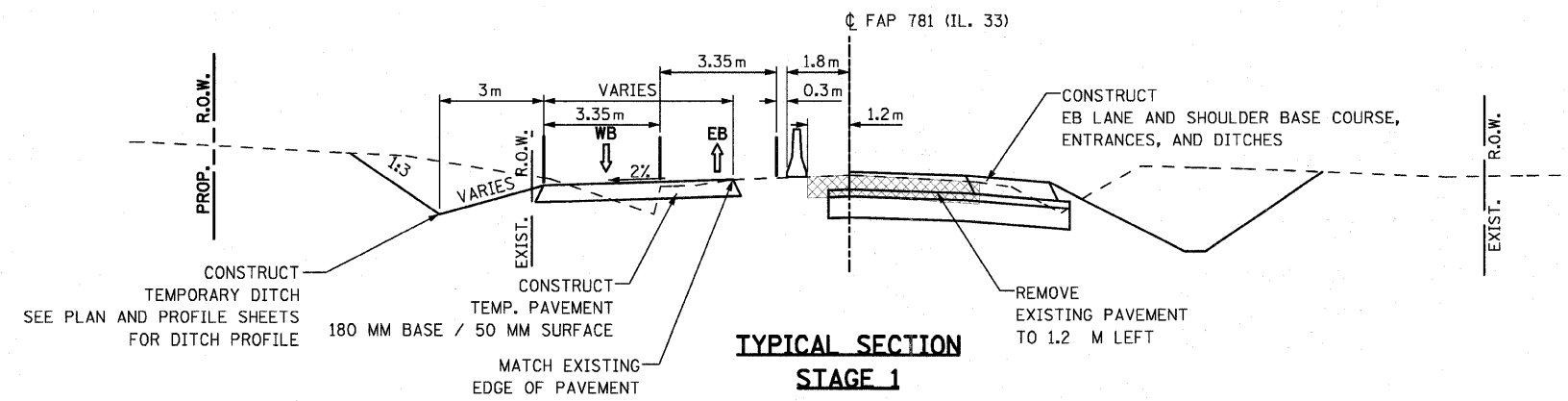

TRAFFIC CONTROL NOTES:

THE CONTRACTOR SHALL UTILIZE TRAFFIC CONTROL STANDARD 701331 DURING EXECUTION OF THIS WORK. TEMPORARY CONCRETE BARRIER AND IMPACT ATTENUATORS SHALL BE PAID FOR AT THE CONTRACT UNIT PRICE FOR SAID ITEMS, ALL OTHER STRIPING, SIGNAGE, ETC. REQUIRED BY THE STANDARD SHALL BE INCLUDED IN THE CONTRACT UNIT PRICE PER EACH FOR TRAFFIC CONTROL AND PROTECTION, STANDARD 701331 (SPECIAL). ALL THREE STAGES OF CONSTRUCTION SHALL CONSTITUTE ONE (1) OCCURRENCE OF THE STANDARD. NO ADDITIONAL COMPENSATION, OTHER THAN RELOCATION OF CONCRETE BARRIER AND IMPACT ATTENUATORS WILL BE ALLOWED FOR ANY CHANGES OR ADJUSTMENTS TO THE TRAFFIC CONTROL DURING THE CONVERSION FROM ONE STAGE TO THE NEXT. LIGHTS ON BARRELS OR BARRICADES SHALL BE BIDIRECTIONAL AND STEADY BURN, EXCEPT, LIGHTS IN THE TAPERS SHALL BE MONODIRECTIONAL.

THE CONTRACTOR SHALL SUPPLY, SET, AND MAINTAIN TWO (2) WIDTH RESTRICTION WARNING SIGNS, AS SHOWN IN THE DETAIL, PRIOR TO COMMENCING WORK UNLESS THEY ARE ALREADY IN PLACE DUE TO CULVERT CONSTRUCTION. THE SIGNS SHALL BE PLACED AT THE INTERSECTIONS OF IL 33 AND IL 49 AND IL 33 AND IL 1, OR OTHER LOCATION, AS DIRECTED BY THE ENGINEER. ALL LABOR AND MATERIALS REQUIRED TO SUPPLY, SET, AND MAINTAIN THESE SIGNS WILL NOT BE PAID FOR SEPARATELY, BUT SHALL BE INCLUDED IN THE CONTRACT UNIT PRICE PER EACH FOR TRAFFIC CONTROL AND PROTECTION, STANDARD 701331 (SPECIAL).

CONSTRUCTION AND SUBSEQUENT REMOVAL OF THE TEMPORARY EMBANKMENT, TEMPORARY PAVEMENT, AND TEMPORARY ENTRANCES, INCLUDING CULVERTS WILL BE PAID FOR AT THE CONTRACT UNIT PRICE FOR SAID ITEMS. EXCAVATION AND GRADING FOR THE TEMPORARY DITCH AND TEMPORARY PAVEMENT WILL NOT BE PAID FOR SEPARATELY, AS THE VOLUMES ARE ACCOUNTED FOR IN THE "EARTH EXCAVATION" AND "EARTH EXCAVATION (WIDENING)" PAY ITEMS.

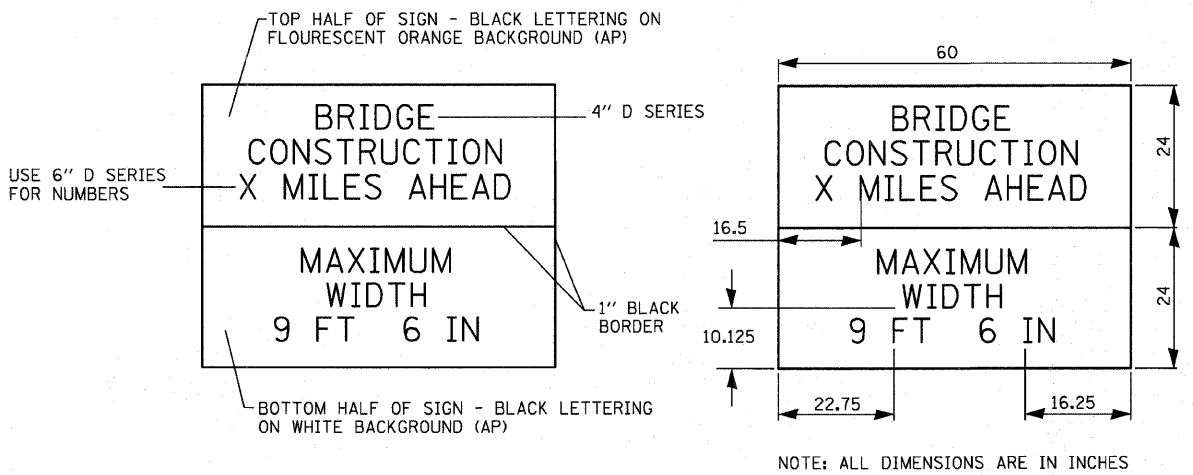

NOTE: ALL DIMENSIONS ARE IN INCHES

WIDTH RESTRICTION SIGN

STAGING NOTES:



1. CONSTRUCT TEMPORARY AGGREGATE ENTRANCES WITH CMP CULVERTS AS NEEDED TO MAINTAIN ACCESS.
2. TWO-WAY / TWO-LANE TRAFFIC SHALL BE RESTORED AT THE END OF THE WORK DAY. TWO-WAY / ONE-LANE TRAFFIC SHALL BE USED ON A LIMITED BASIS, WHEN REQUIRED, UTILIZING THE APPROPRIATE STANDARD.
3. FINAL HMA SURFACE COURSE SHALL BE PLACED THROUGHOUT THE PROJECT LIMITS AS A SEPARATE STAGE.

PLOT DATE = 11/6/2008 FILE NAME = H:\4420\Enr\112\112.stgpl.dgn

HMG JOB NO. 4420

F.A.P. RTE.	SECTION	COUNTY	TOTAL SHEETS	SHEET NO.
781	1YRS, 2ZRS-1	CRAWFORD	378	113
STA. TO STA.				
FED. ROAD DIST. NO.		ILLINOIS	FED. AID PROJECT	

LEGEND

-  CONSTRUCTION THIS STAGE
-  TEMPORARY PAVEMENT

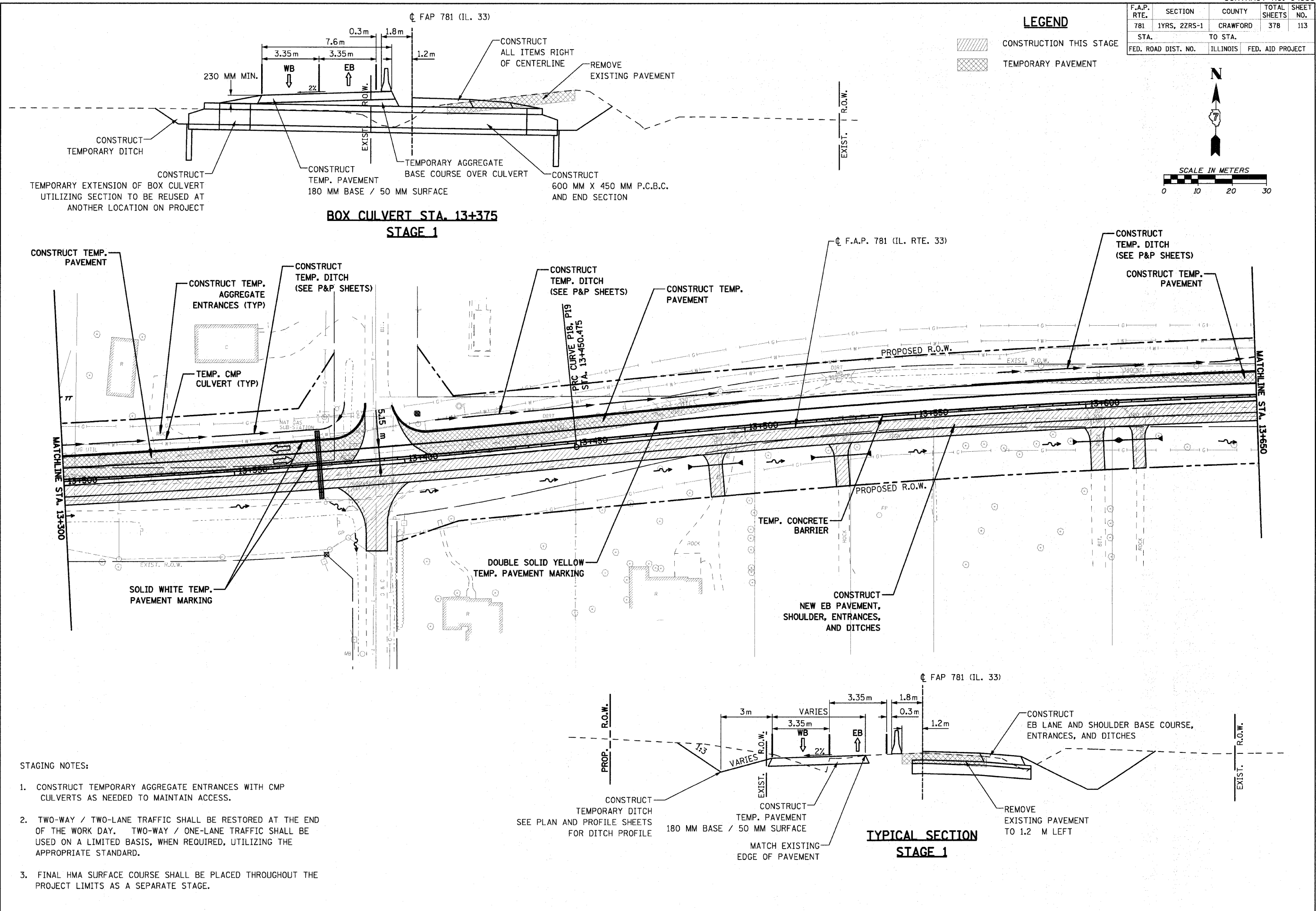
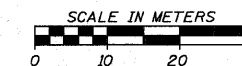

**BOX CULVERT STA. 13+375
STAGE 1**

**TYPICAL SECTION
STAGE 1**



- STAGING NOTES:
1. CONSTRUCT TEMPORARY AGGREGATE ENTRANCES WITH CMP CULVERTS AS NEEDED TO MAINTAIN ACCESS.
 2. TWO-WAY / TWO-LANE TRAFFIC SHALL BE RESTORED AT THE END OF THE WORK DAY. TWO-WAY / ONE-LANE TRAFFIC SHALL BE USED ON A LIMITED BASIS, WHEN REQUIRED, UTILIZING THE APPROPRIATE STANDARD.
 3. FINAL HMA SURFACE COURSE SHALL BE PLACED THROUGHOUT THE PROJECT LIMITS AS A SEPARATE STAGE.

PLOT DATE = 11/6/2008
 FILE NAME = H:\428\Final\Pilana Drawings\1744533\SH113_stage1.dgn

HMG JOB NO. 4490

F.A.P. RTE.	SECTION	COUNTY	TOTAL SHEETS	SHEET NO.
781	1YRS, 2ZRS-1	CRAWFORD	378	114
STA. TO STA.				
FED. ROAD DIST. NO.		ILLINOIS	FED. AID PROJECT	

LEGEND

-  CONSTRUCTION THIS STAGE
-  TEMPORARY PAVEMENT

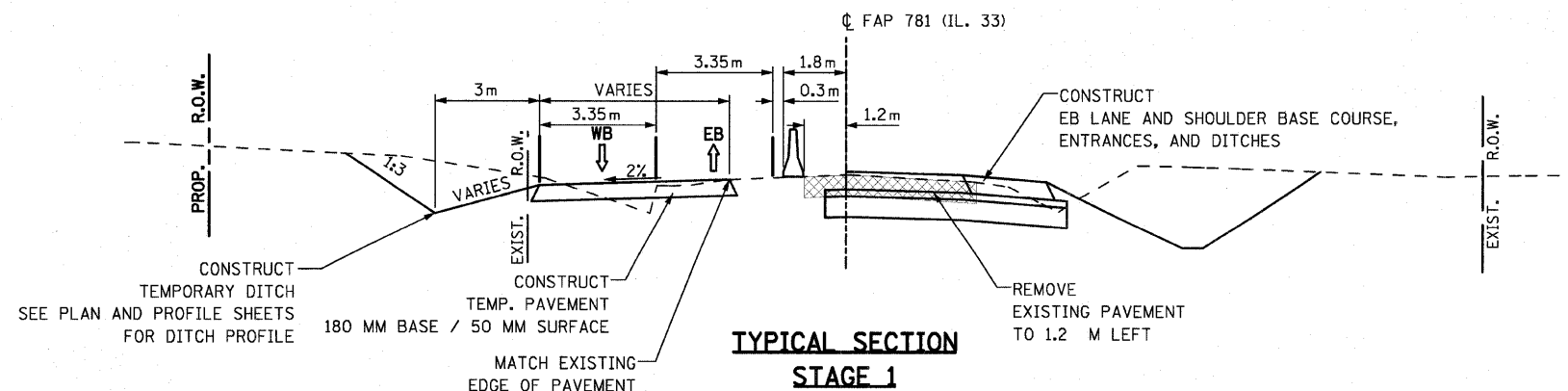
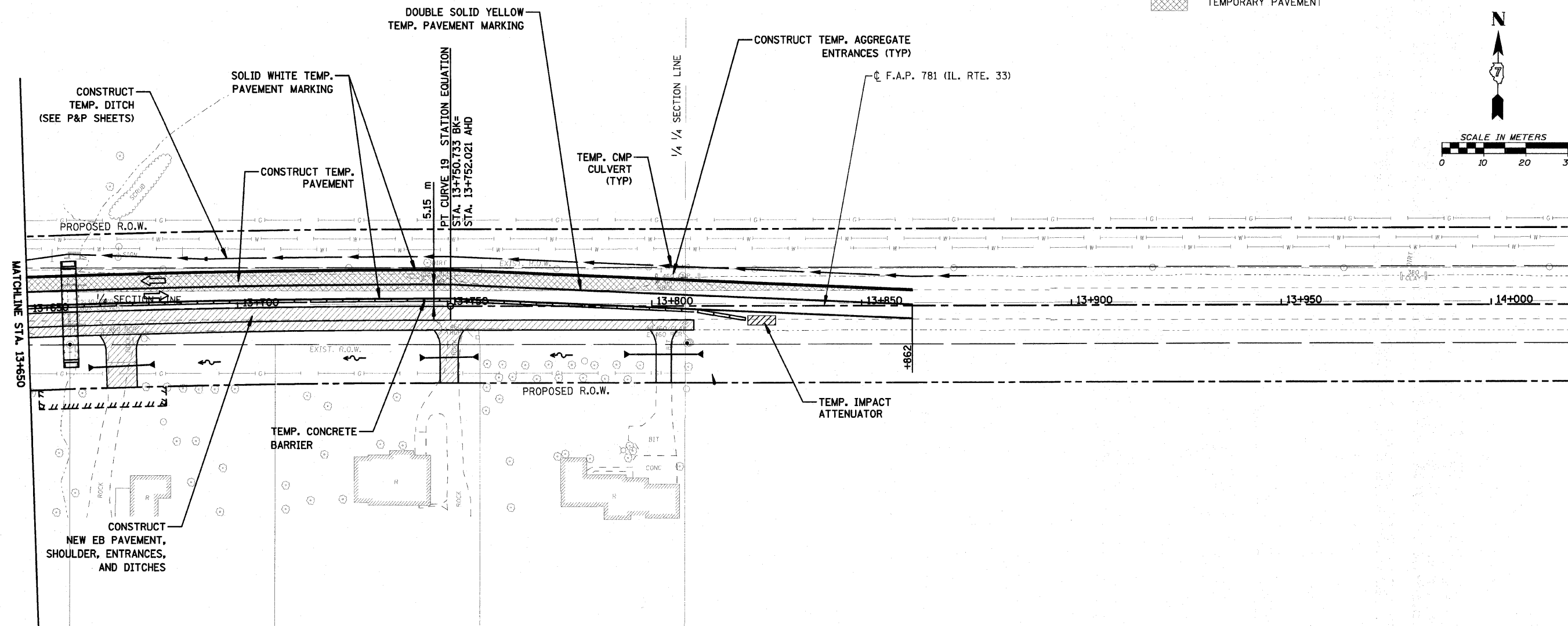
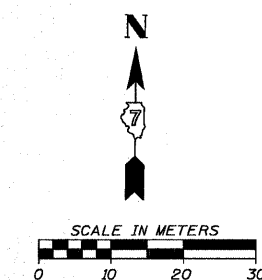

STAGING NOTES:

1. CONSTRUCT TEMPORARY AGGREGATE ENTRANCES WITH CMP CULVERTS AS NEEDED TO MAINTAIN ACCESS.
2. TWO-WAY / TWO-LANE TRAFFIC SHALL BE RESTORED AT THE END OF THE WORK DAY. TWO-WAY / ONE-LANE TRAFFIC SHALL BE USED ON A LIMITED BASIS, WHEN REQUIRED, UTILIZING THE APPROPRIATE STANDARD.
3. FINAL HMA SURFACE COURSE SHALL BE PLACED THROUGHOUT THE PROJECT LIMITS AS A SEPARATE STAGE.

PLOT DATE = 11/6/2008
 FILE NAME = H:\4420\Final\Plans\Drawings\0794533\SHT_114_stage1.dgn

HMG JOB NO. 4420

F.A.P. RTE.	SECTION	COUNTY	TOTAL SHEETS	SHEET NO.
781	1YRS, 2ZRS-1	CRAWFORD	378	115
STA. TO STA.				
FED. ROAD DIST. NO.		ILLINOIS	FED. AID PROJECT	

LEGEND

 CONSTRUCTION THIS STAGE

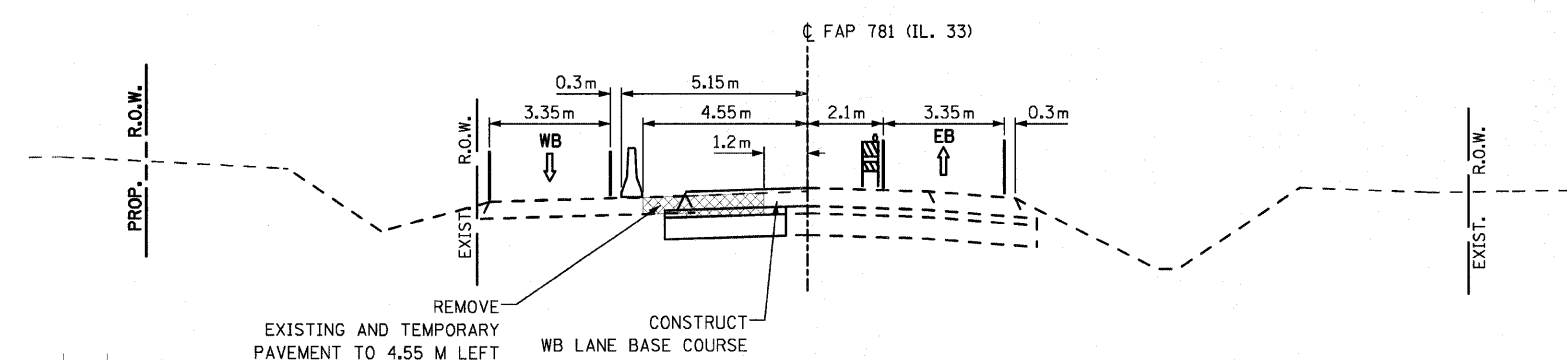
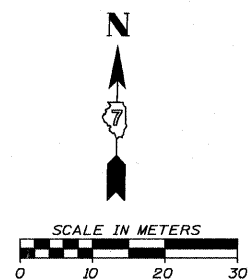

**TYPICAL SECTION
STAGE 2**

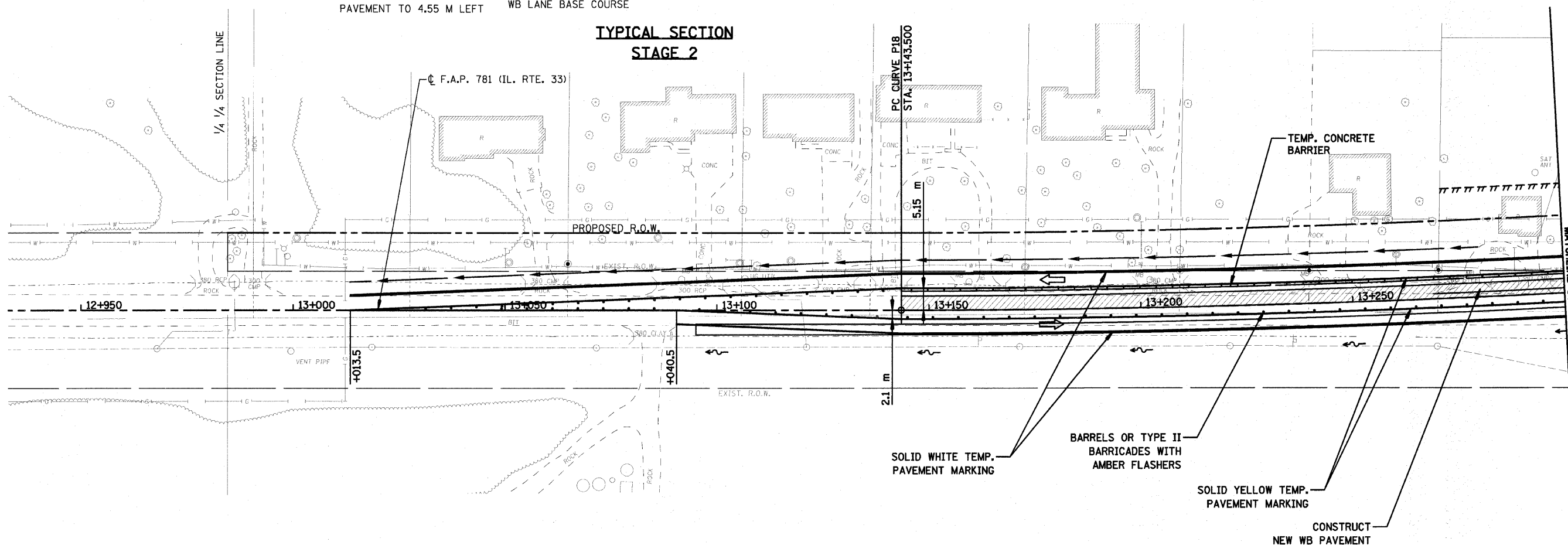

STAGING NOTES:

1. MAINTAIN TEMPORARY AGGREGATE ENTRANCES AS NEEDED TO MAINTAIN ACCESS.
2. TWO-WAY / TWO-LANE TRAFFIC SHALL BE RESTORED AT THE END OF THE WORK DAY. TWO-WAY / ONE-LANE TRAFFIC SHALL BE USED ON A LIMITED BASIS, WHEN REQUIRED, UTILIZING THE APPROPRIATE STANDARD.
3. FINAL HMA SURFACE COURSE SHALL BE PLACED THROUGHOUT THE PROJECT LIMITS AS A SEPARATE STAGE.

PLOT DATE = 11/6/2008
 FILE NAME = H:\4428\Final\Plans\Drawings\794533\SH2_115_stage2_1.dgn

HMG JOB NO. 4420

F.A.P. RTE.	SECTION	COUNTY	TOTAL SHEETS	SHEET NO.
781	1YRS, 2ZRS-1	CRAWFORD	378	116
STA. 781		TO STA. 116		
FED. ROAD DIST. NO.		ILLINOIS	FED. AID PROJECT	

LEGEND

 CONSTRUCTION THIS STAGE

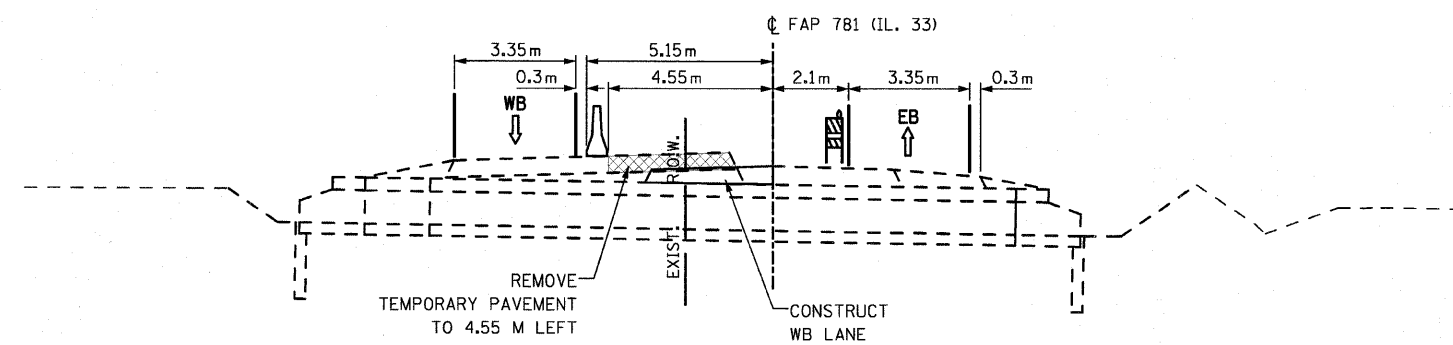
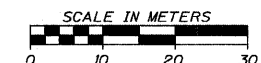

**BOX CULVERT STA. 13+375
STAGE 2**

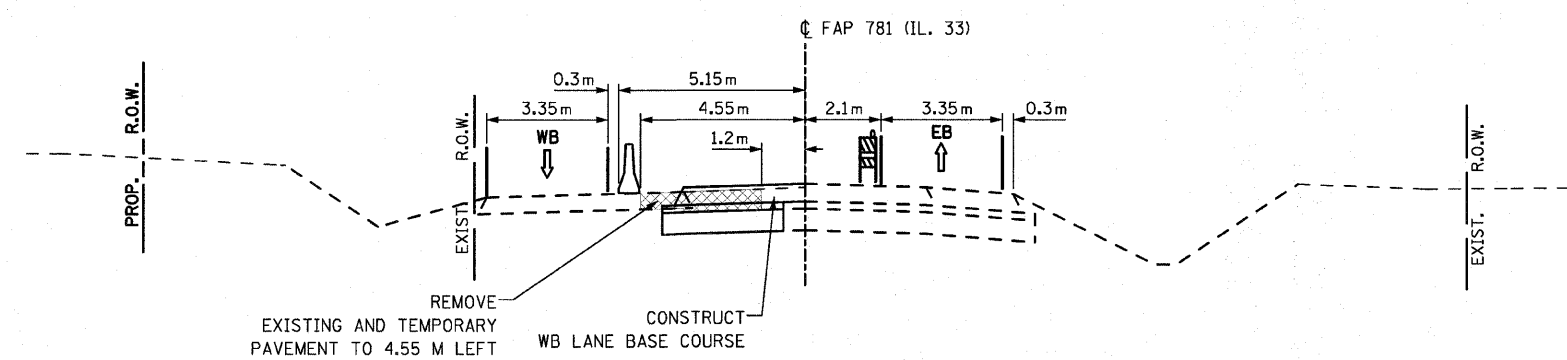
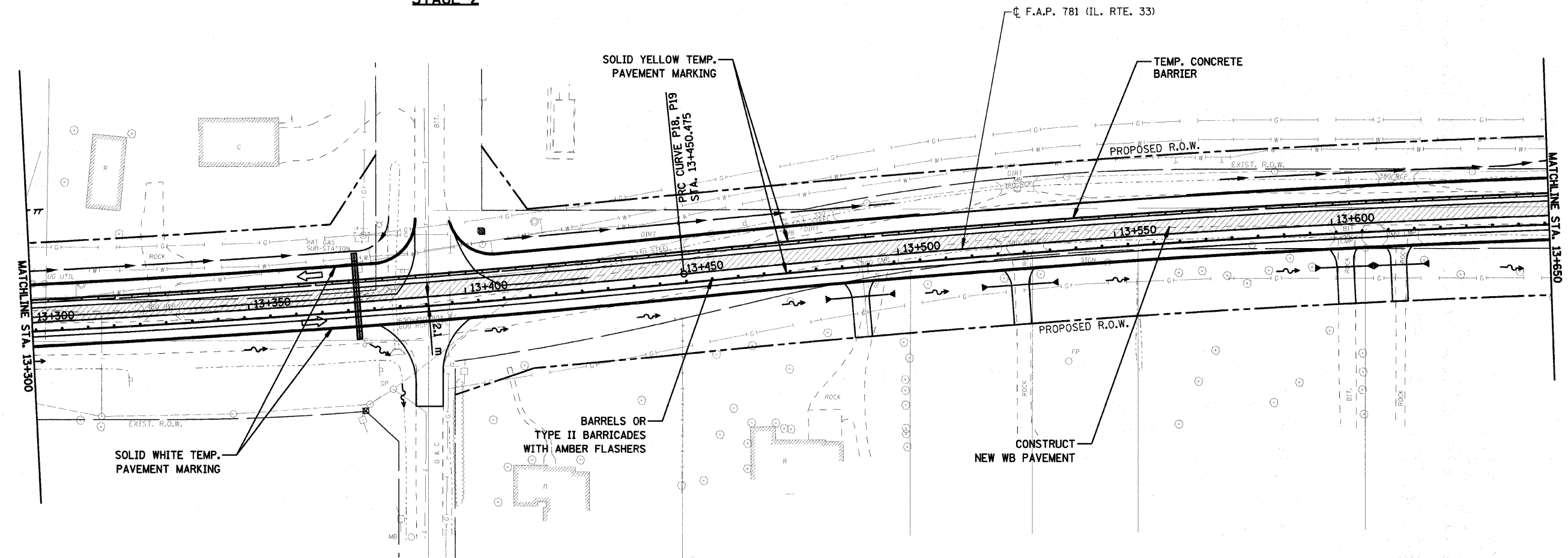

**TYPICAL SECTION
STAGE 2**

STAGING NOTES:

1. MAINTAIN TEMPORARY AGGREGATE ENTRANCES AS NEEDED TO MAINTAIN ACCESS.
2. TWO-WAY / TWO-LANE TRAFFIC SHALL BE RESTORED AT THE END OF THE WORK DAY. TWO-WAY / ONE-LANE TRAFFIC SHALL BE USED ON A LIMITED BASIS, WHEN REQUIRED, UTILIZING THE APPROPRIATE STANDARD.
3. FINAL HMA SURFACE COURSE SHALL BE PLACED THROUGHOUT THE PROJECT LIMITS AS A SEPARATE STAGE.

PLOT DATE = 11/6/2008
FILE NAME = H:\4420\Final\Plans\Drawings\174533\SH2\116_stage2.dgn

HMG JOB NO. 4420

F.A.P. RTE.	SECTION	COUNTY	TOTAL SHEETS	SHEET NO.
781	1YRS, 2ZRS-1	CRAWFORD	378	117
STA.	TO STA.			
FED. ROAD DIST. NO.	ILLINOIS	FED. AID PROJECT		

LEGEND

 CONSTRUCTION THIS STAGE

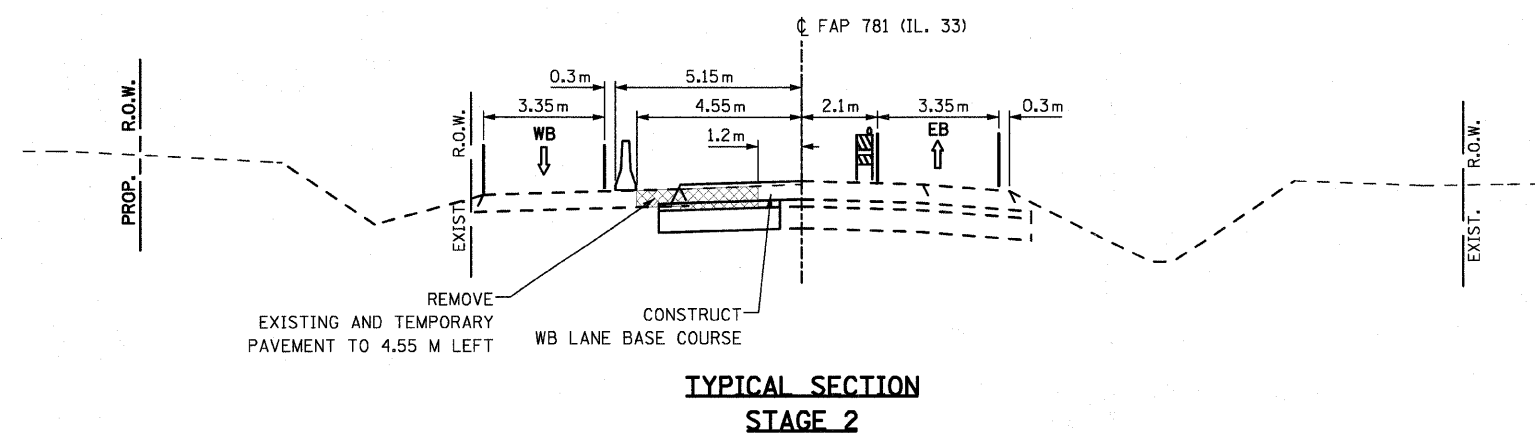
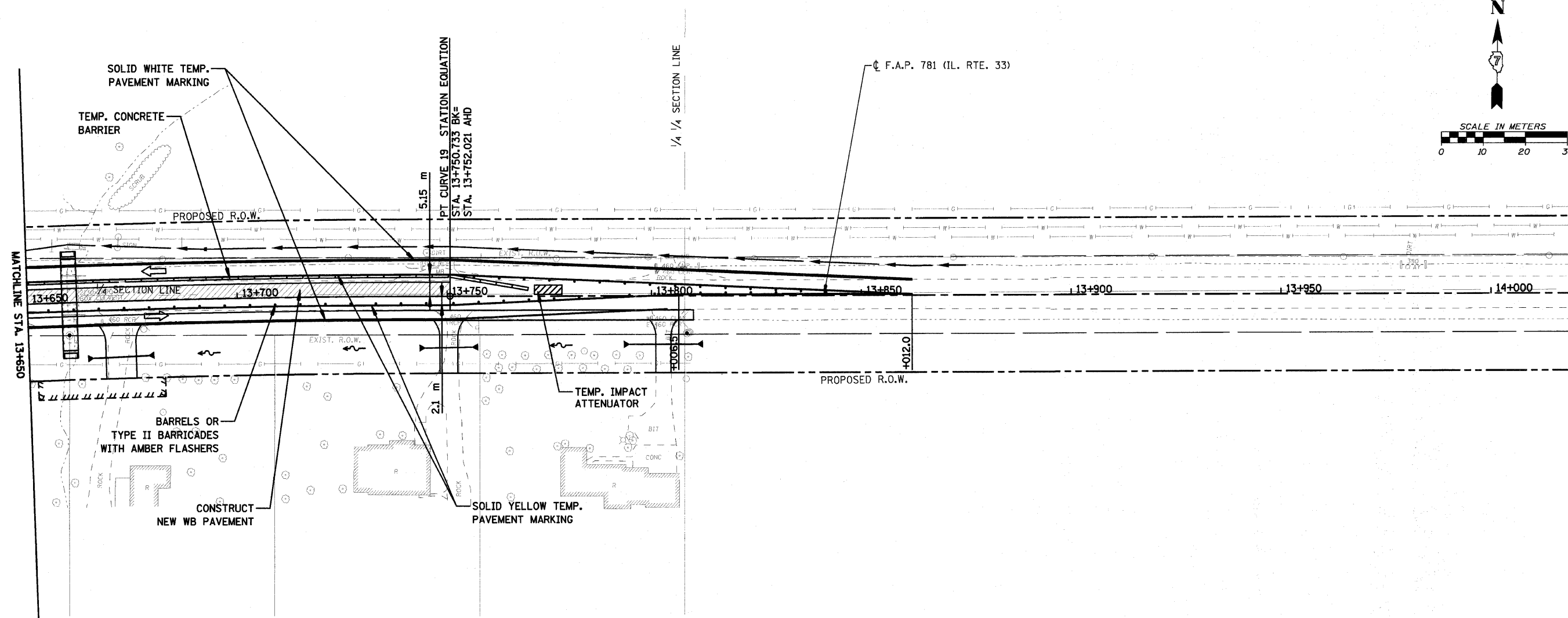
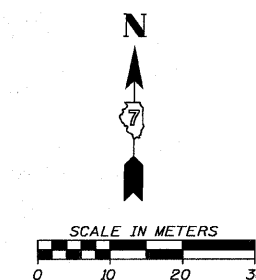

**TYPICAL SECTION
STAGE 2**

NOTES:

1. MAINTAIN TEMPORARY AGGREGATE ENTRANCES AS NEEDED TO MAINTAIN ACCESS.
2. TWO-WAY / TWO-LANE TRAFFIC SHALL BE RESTORED AT THE END OF THE WORK DAY. TWO-WAY / ONE-LANE TRAFFIC SHALL BE USED ON A LIMITED BASIS, WHEN REQUIRED, UTILIZING THE APPROPRIATE STANDARD.
3. FINAL HMA SURFACE COURSE SHALL BE PLACED THROUGHOUT THE PROJECT LIMITS AS A SEPARATE STAGE.

PLOT DATE = 11/6/2008
 FILE NAME = H:\4420\Final\Plans\0794533\SH117_stage2_3.dgn

HMG JOB NO. 4420

F.A.P. RTE.	SECTION	COUNTY	TOTAL SHEETS	SHEET NO.
781	1YRS, 2ZRS-1	CRAWFORD	378	118
STA.		TO STA.		
FED. ROAD DIST. NO.		ILLINOIS	FED. AID PROJECT	

LEGEND

 CONSTRUCTION THIS STAGE

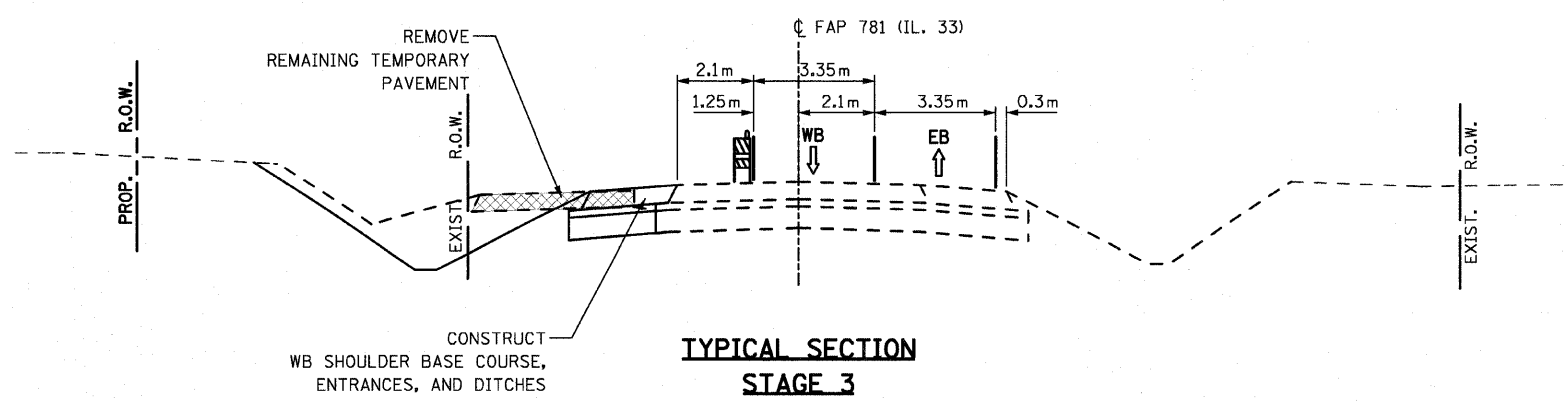
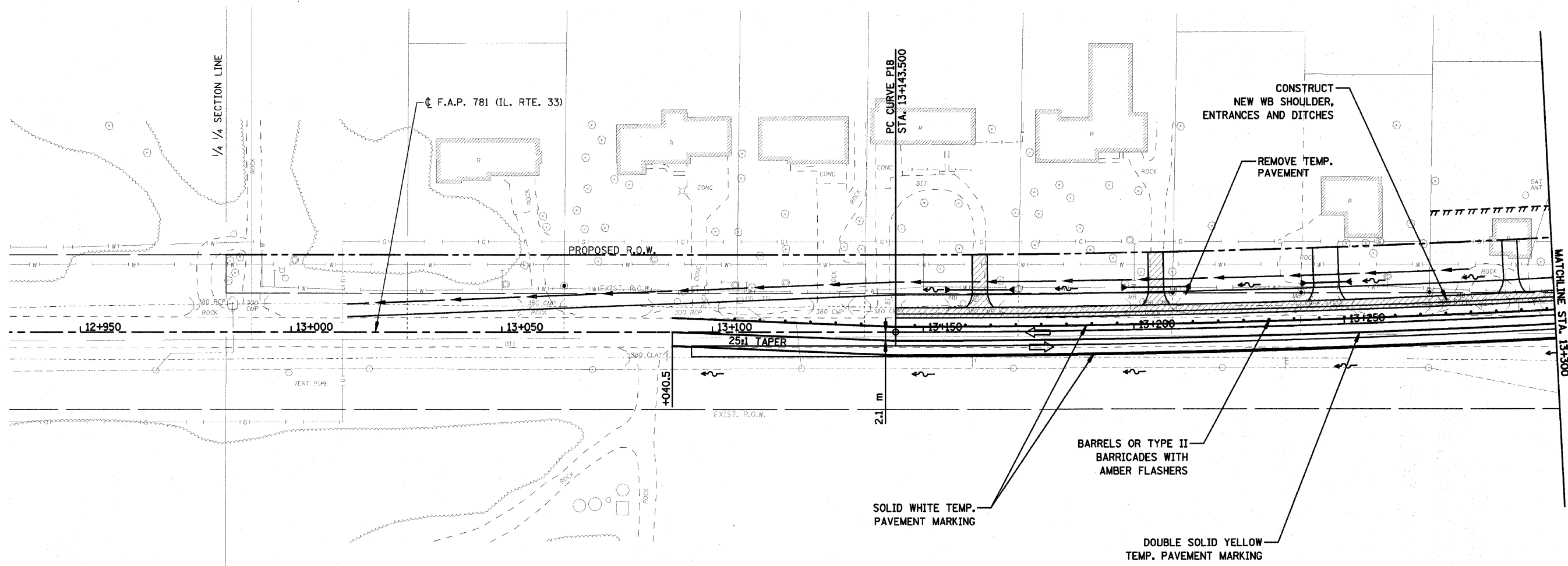
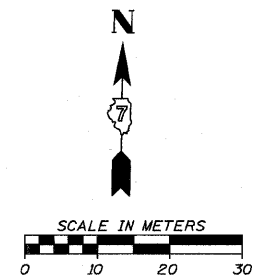

NOTES:

1. MAINTAIN TEMPORARY AGGREGATE ENTRANCES AS NEEDED TO MAINTAIN ACCESS.
2. TWO-WAY / TWO-LANE TRAFFIC SHALL BE RESTORED AT THE END OF THE WORK DAY. TWO-WAY / ONE-LANE TRAFFIC SHALL BE USED ON A LIMITED BASIS, WHEN REQUIRED, UTILIZING THE APPROPRIATE STANDARD.
3. FINAL HMA SURFACE COURSE SHALL BE PLACED THROUGHOUT THE PROJECT LIMITS AS A SEPARATE STAGE.

PLOT DATE = 11/6/2008
FILE NAME = H:\4428\Final\Plans\Drawings\1794533\SH118_stage3_1.dgn

HMG JOB NO. 4420

F.A.P. RTE.	SECTION	COUNTY	TOTAL SHEET SHEETS	NO.
781	1YRS, 2ZRS-1	CRAWFORD	378	119
STA. TO STA.				
FED. ROAD DIST. NO.	ILLINOIS	FED. AID PROJECT		

LEGEND

 CONSTRUCTION THIS STAGE

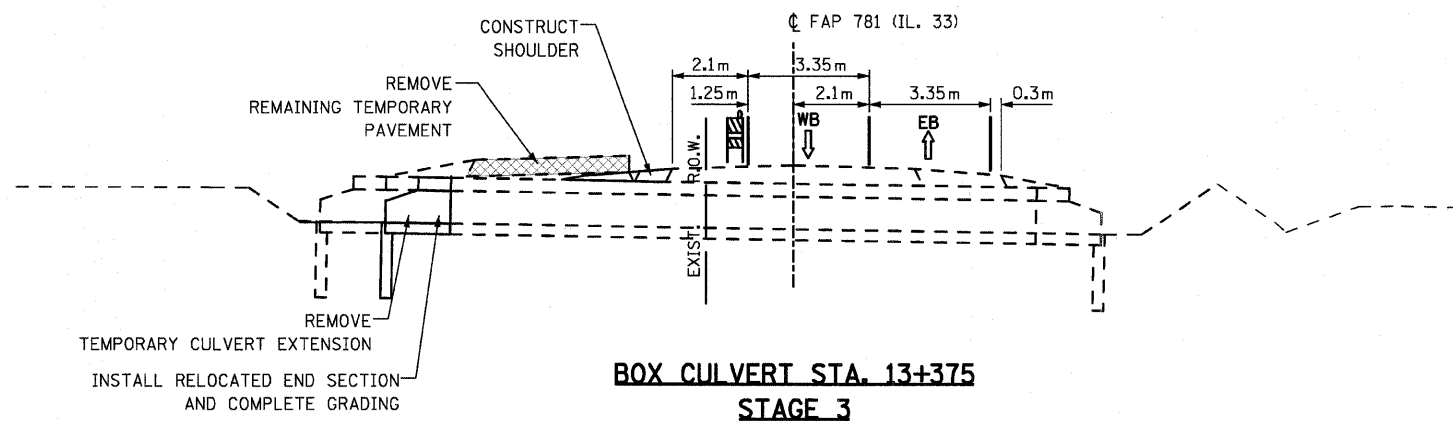
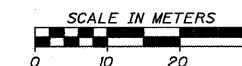

**BOX CULVERT STA. 13+375
STAGE 3**

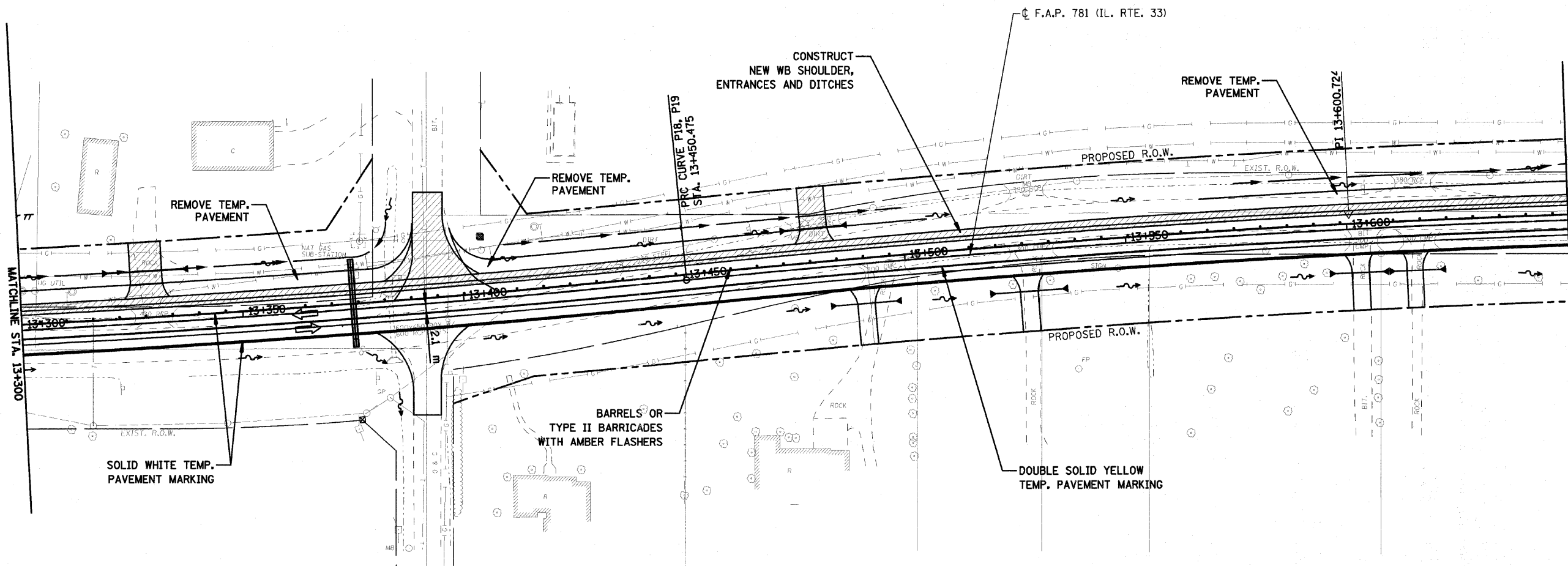

NOTES:

1. MAINTAIN TEMPORARY AGGREGATE ENTRANCES AS NEEDED TO MAINTAIN ACCESS.
2. TWO-WAY / TWO-LANE TRAFFIC SHALL BE RESTORED AT THE END OF THE WORK DAY. TWO-WAY / ONE-LANE TRAFFIC SHALL BE USED ON A LIMITED BASIS, WHEN REQUIRED, UTILIZING THE APPROPRIATE STANDARD.
3. FINAL HMA SURFACE COURSE SHALL BE PLACED THROUGHOUT THE PROJECT LIMITS AS A SEPARATE STAGE.

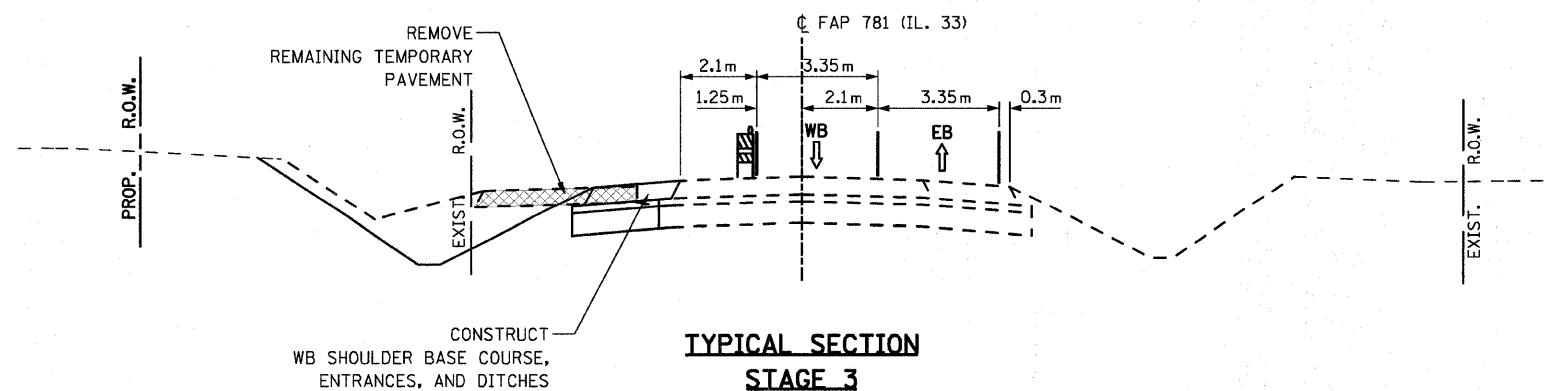

**TYPICAL SECTION
STAGE 3**

PLOT DATE = 11/6/2008
FILE NAME = H:\4420\Final\Drawings\0794533\SH1_119_stage3_2.dgn

HMG JOB NO. 4420

F.A.P. RTE.	SECTION	COUNTY	TOTAL SHEETS	SHEET NO.
781	1YRS, 2ZRS-1	CRAWFORD	378	120
STA.	TO STA.			
FED. ROAD DIST. NO.	ILLINOIS	FED. AID PROJECT		

LEGEND

 CONSTRUCTION THIS STAGE

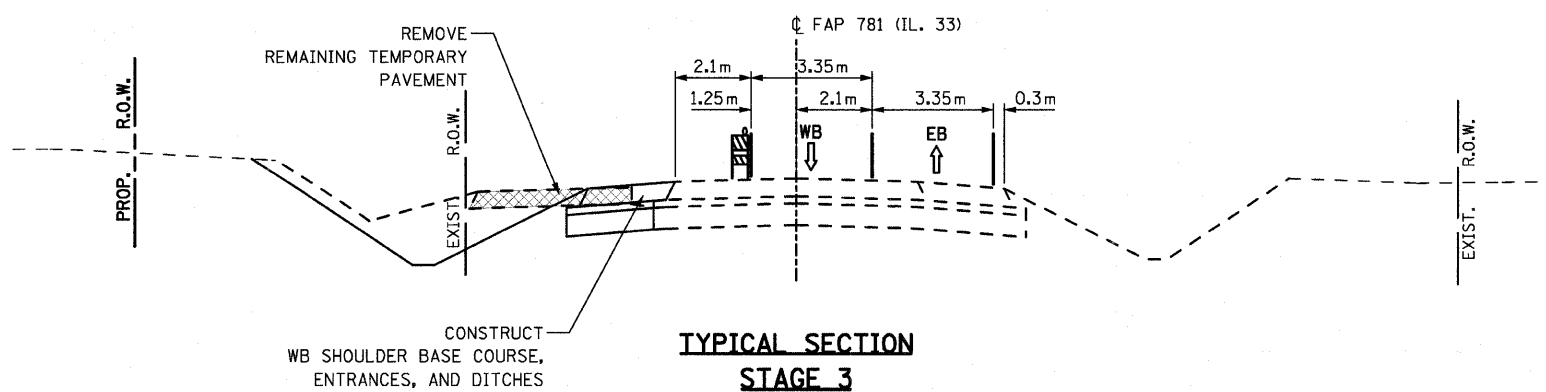
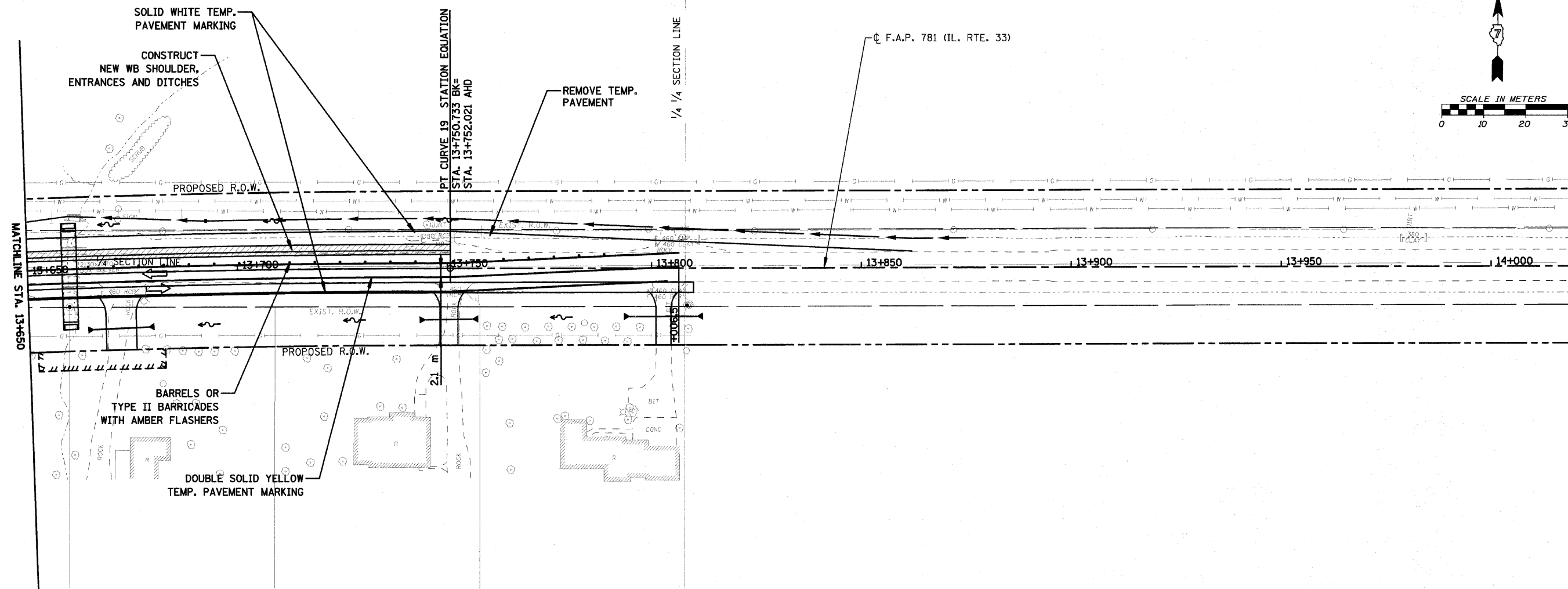
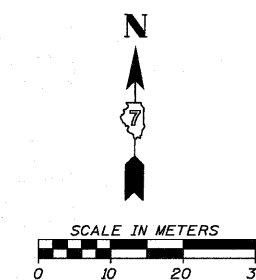

NOTES:

1. MAINTAIN TEMPORARY AGGREGATE ENTRANCES AS NEEDED TO MAINTAIN ACCESS.
2. TWO-WAY / TWO-LANE TRAFFIC SHALL BE RESTORED AT THE END OF THE WORK DAY. TWO-WAY / ONE-LANE TRAFFIC SHALL BE USED ON A LIMITED BASIS, WHEN REQUIRED, UTILIZING THE APPROPRIATE STANDARD.
3. FINAL HMA SURFACE COURSE SHALL BE PLACED THROUGHOUT THE PROJECT LIMITS AS A SEPARATE STAGE.

PLOT DATE = 11/6/2008
FILE NAME = H:\4420\Final Drawings\0794533\SH1.120_stage3.3.dgn

P&R JOB NO. 4420

F.A.P. RTE.	SECTION	COUNTY	TOTAL SHEETS	SHEET NO.
781	1YRS, 2ZRS-1	CRAWFORD	378	121
STA. 2+750		TO STA. 2+800		
FED. ROAD DIST. NO.	ILLINOIS	FED. AID PROJECT		

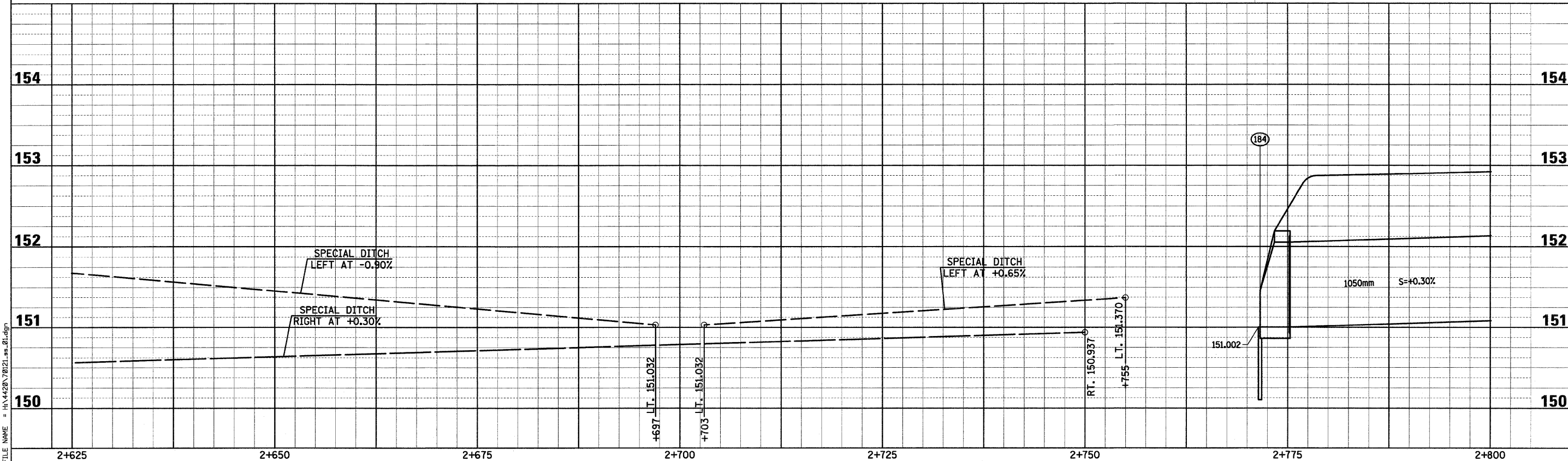
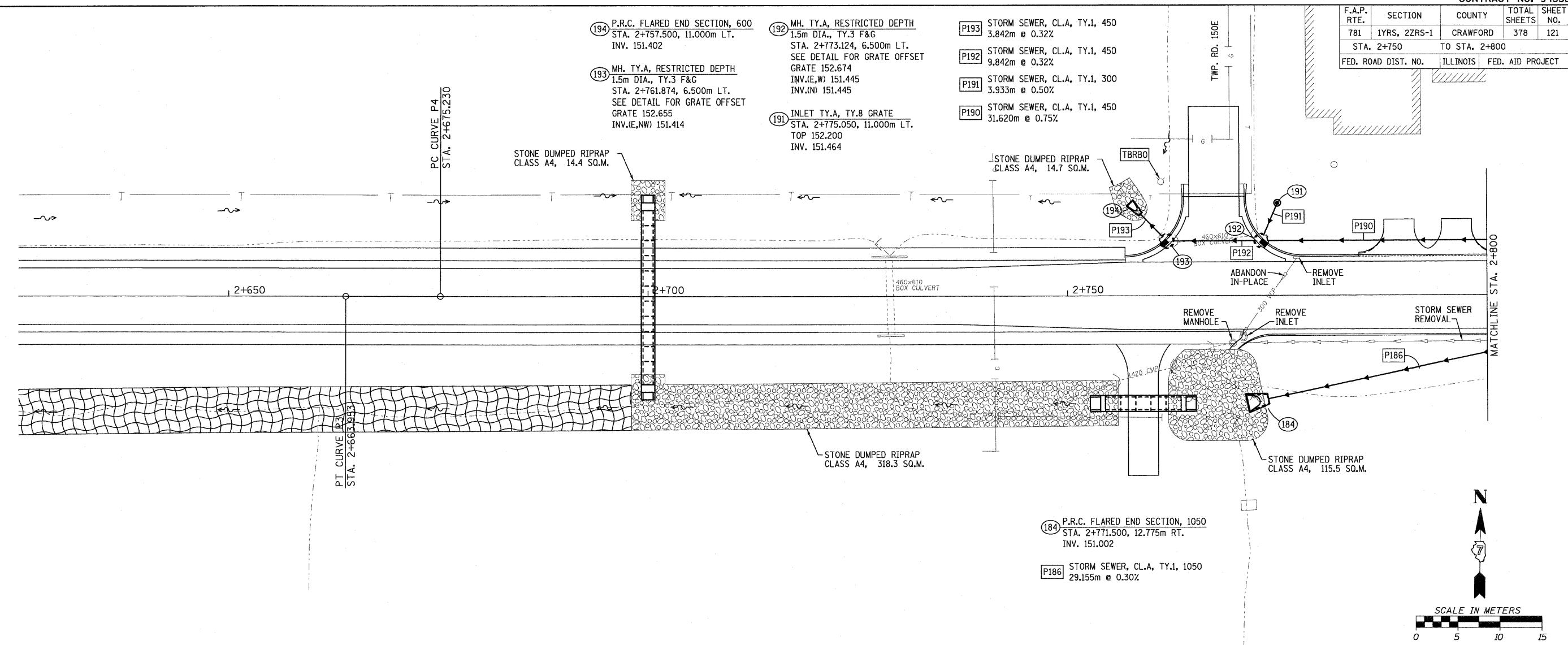

Sheet: 1
 Angle: 0.5629
 Chain: P_IL33

PLOT DATE = 3/20/2008
 FILE NAME = H:\1420\170121.asa.plt.dgn

HMG JOB NO. 4420

F.A.P. RTE.	SECTION	COUNTY	TOTAL SHEETS	SHEET NO.
781	1YRS, 2ZRS-1	CRAWFORD	378	122
STA. 2+800		TO STA. 2+975		
FED. ROAD DIST. NO.	ILLINOIS	FED. AID PROJECT		

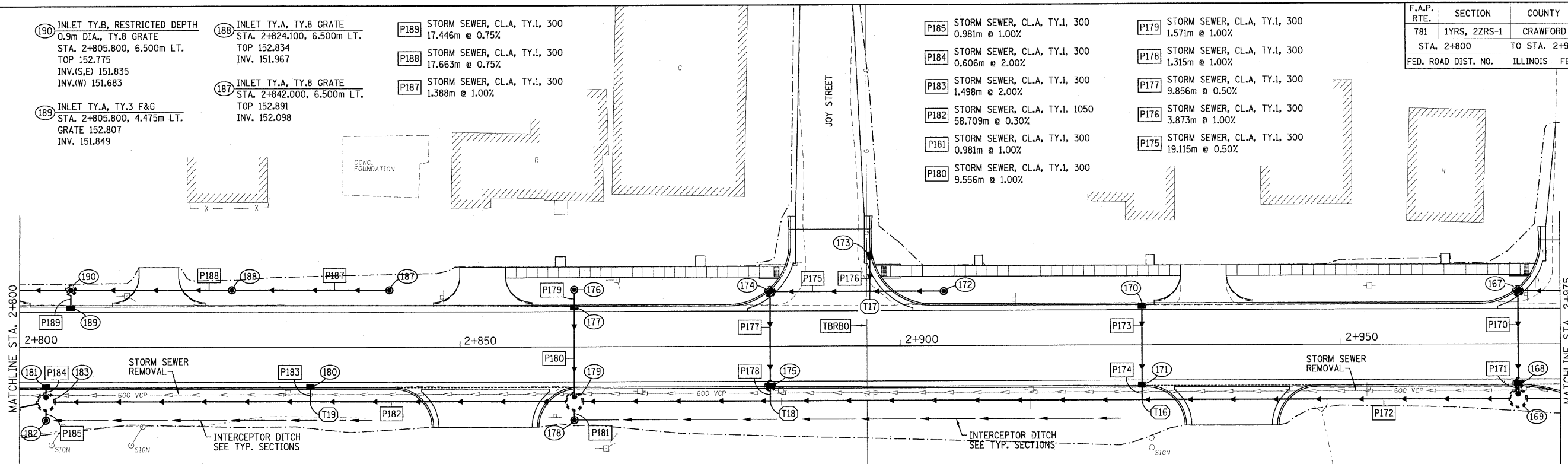

- 189 INLET TY.A, TY.3 F&G
STA. 2+805.800, 4.475m LT.
GRATE 152.807
INV. 151.849
- 188 INLET TY.A, TY.8 GRATE
STA. 2+824.100, 6.500m LT.
TOP 152.834
INV. 151.967
- 187 INLET TY.A, TY.8 GRATE
STA. 2+842.000, 6.500m LT.
TOP 152.891
INV. 152.098
- 186 INLET TY.B, RESTRICTED DEPTH
0.9m DIA., TY.8 GRATE
STA. 2+805.800, 6.500m LT.
TOP 152.775
INV.(S,E) 151.835
INV.(W) 151.683
- 185 STORM SEWER, CL.A, TY.1, 300
17.446m @ 0.75%
- 184 STORM SEWER, CL.A, TY.1, 300
17.663m @ 0.75%
- 183 STORM SEWER, CL.A, TY.1, 300
1.388m @ 1.00%
- 182 STORM SEWER, CL.A, TY.1, 300
0.981m @ 1.00%
- 181 STORM SEWER, CL.A, TY.1, 300
0.606m @ 2.00%
- 180 STORM SEWER, CL.A, TY.1, 300
1.498m @ 2.00%
- 179 STORM SEWER, CL.A, TY.1, 300
58.709m @ 0.30%
- 178 STORM SEWER, CL.A, TY.1, 300
0.981m @ 1.00%
- 177 STORM SEWER, CL.A, TY.1, 300
9.556m @ 1.00%
- 176 STORM SEWER, CL.A, TY.1, 300
1.571m @ 1.00%
- 175 STORM SEWER, CL.A, TY.1, 300
1.315m @ 1.00%
- 174 STORM SEWER, CL.A, TY.1, 300
9.856m @ 0.50%
- 173 STORM SEWER, CL.A, TY.1, 300
3.873m @ 1.00%
- 172 STORM SEWER, CL.A, TY.1, 300
19.115m @ 0.50%
- 171 STORM SEWER, CL.A, TY.1, 300
1.498m @ 2.00%
- 170 STORM SEWER, CL.A, TY.1, 300
8.496m @ 1.00%
- 169 STORM SEWER, CL.A, TY.1, 1050
105.914m @ 0.30%
- 168 STORM SEWER, CL.A, TY.1, 300
0.424m @ 1.00%
- 167 STORM SEWER, CL.A, TY.1, 300
9.656m @ 0.50%
- 166 REINFORCED CONC. PIPE TEE
1050 PIPE WITH 300 RISER
- 165 REINFORCED CONC. PIPE TEE
1050 PIPE WITH 300 RISER
- 164 REINFORCED CONC. PIPE TEE
300 PIPE WITH 300 RISER
- 163 REINFORCED CONC. PIPE TEE
1050 PIPE WITH 300 RISER
- 162 MH. TY.A, RESTRICTED DEPTH
1.8m DIA., TY.1 FRAME, CL. LID
STA. 2+803.000, 6.200m RT.
SEE DETAIL FOR FRAME OFFSET
TOP 152.930
INV.(E,SW) 151.090
INV.(N,S) 151.547
- 161 INLET TY.A, TY.3 F&G
STA. 2+833.000, 4.475m RT.
GRATE 152.893
INV. 151.589
- 160 MH. TY.A, RESTRICTED DEPTH
1.8m DIA., TY.1 FRAME, CL. LID
STA. 2+863.000, 6.200m RT.
SEE DETAIL FOR FRAME OFFSET
TOP 153.121
INV.(E,SW) 151.266
INV.(N,S) 151.723
- 159 INLET TY.A, TY.8 GRATE
STA. 2+803.000, 8.300m RT.
TOP 152.631
INV. 151.557
- 158 INLET TY.A, TY.3 F&G
STA. 2+803.000, 4.475m RT.
GRATE 152.798
INV. 151.559
- 157 INLET TY.A, TY.3 F&G
STA. 2+863.000, 4.475m LT.
GRATE 152.989
INV. 151.818
- 156 INLET TY.A, TY.8 GRATE
STA. 2+863.000, 6.500m LT.
TOP 152.958
INV. 151.834
- 155 INLET TY.B, RESTRICTED DEPTH
0.9m DIA., TY.3 F&G
STA. 2+885.248, 4.475m RT.
GRATE 153.027
INV.(E,S) 151.774
- 154 INLET TY.A, TY.3 F&G
STA. 2+927.500, 4.475m RT.
GRATE 153.196
INV. 151.869
- 153 INLET TY.A, TY.3 F&G
STA. 2+927.500, 4.475m LT.
GRATE 153.196
INV. 151.954
- 152 MH. TY.A, RESTRICTED DEPTH
1.8m DIA., TY.1 FRAME, CL. LID
STA. 2+970.205, 6.200m RT.
SEE DETAIL FOR FRAME OFFSET
TOP 153.593
INV.(E) 151.736
INV.(W) 151.584
INV.(N) 152.345
- 151 INLET TY.B, RESTRICTED DEPTH
0.9m DIA., TY.3 F&G
STA. 2+970.205, 4.475m RT.
GRATE 153.345
INV.(N,S) 152.349
- 150 INLET TY.B, RESTRICTED DEPTH
0.9m DIA., TY.3 F&G
STA. 2+970.205, 6.000m LT.
GRATE 153.357
INV.(E,S) 152.397

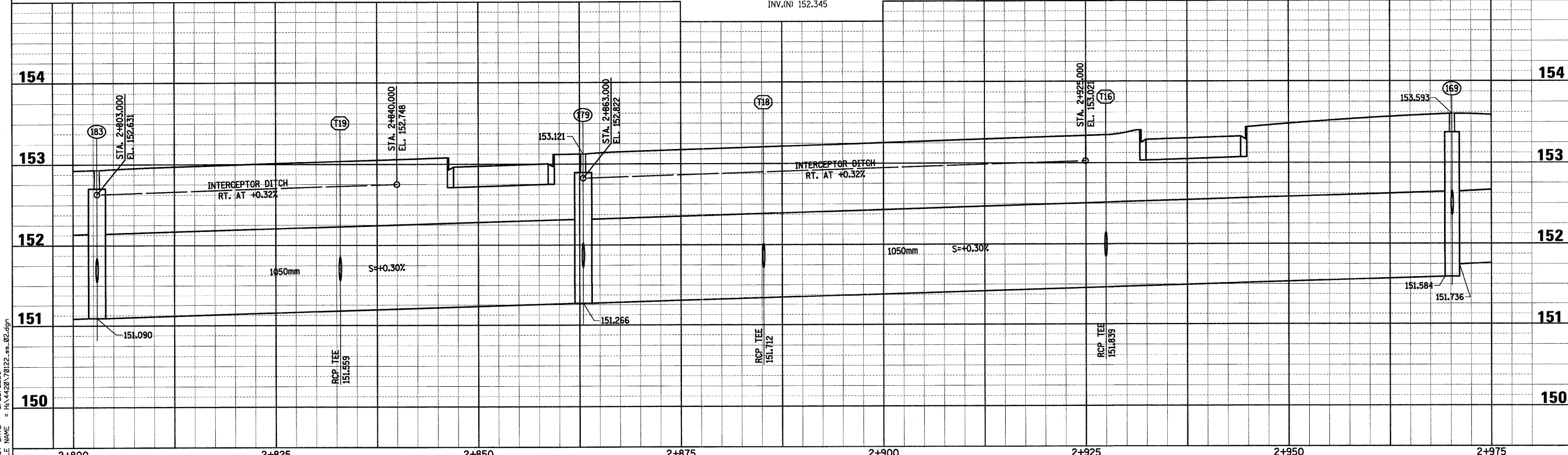
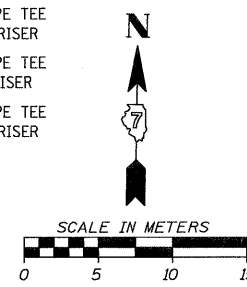

Sheet: 2
Angle: 1.0118
Chain: P_IL33

PLOT DATE = 3/29/2008
FILE NAME = H:\4420\70122_02.dgn

HMG JOB NO. 4420

F.A.P. RTE.	SECTION	COUNTY	TOTAL SHEETS	SHEET NO.
781	1YRS, 2ZRS-1	CRAWFORD	378	123
STA. 2+975		TO STA. 3+150		
FED. ROAD DIST. NO.	ILLINOIS	FED. AID PROJECT		

- | | | |
|--|--|--|
| P169 STORM SEWER, CL.A, TY.1, 300
13.553m @ 0.50% | P163 STORM SEWER, CL.A, TY.1, 300
8.496m @ 1.00% | P157 STORM SEWER, CL.A, TY.1, 900
2.706m @ 0.54% |
| P168 STORM SEWER, CL.A, TY.1, 300
1.498m @ 2.00% | P162 STORM SEWER, CL.A, TY.1, 300
1.498m @ 2.00% | P156 STORM SEWER, CL.A, TY.1, 900
7.384m @ 0.54% |
| P167 STORM SEWER, CL.A, TY.1, 300
8.496m @ 1.00% | P161 STORM SEWER, CL.A, TY.1, 900
52.300m @ 0.50% | T15 REINFORCED CONC. PIPE TEE
900 PIPE WITH 300 RISER |
| P166 STORM SEWER, CL.A, TY.1, 300
1.498m @ 2.00% | P160 STORM SEWER, CL.A, TY.1, 300
5.372m @ 1.00% | T14 REINFORCED CONC. PIPE TEE
900 PIPE WITH 300 RISER |
| P165 STORM SEWER, CL.A, TY.1, 900
90.347m @ 0.50% | P159 STORM SEWER, CL.A, TY.1, 300
11.099m @ 0.50% | T13 REINFORCED CONC. PIPE TEE
900 PIPE WITH 300 RISER |
| P164 STORM SEWER, CL.A, TY.1, 300
0.606m @ 2.00% | P158 STORM SEWER, CL.A, TY.1, 300
13.067m @ 0.50% | |

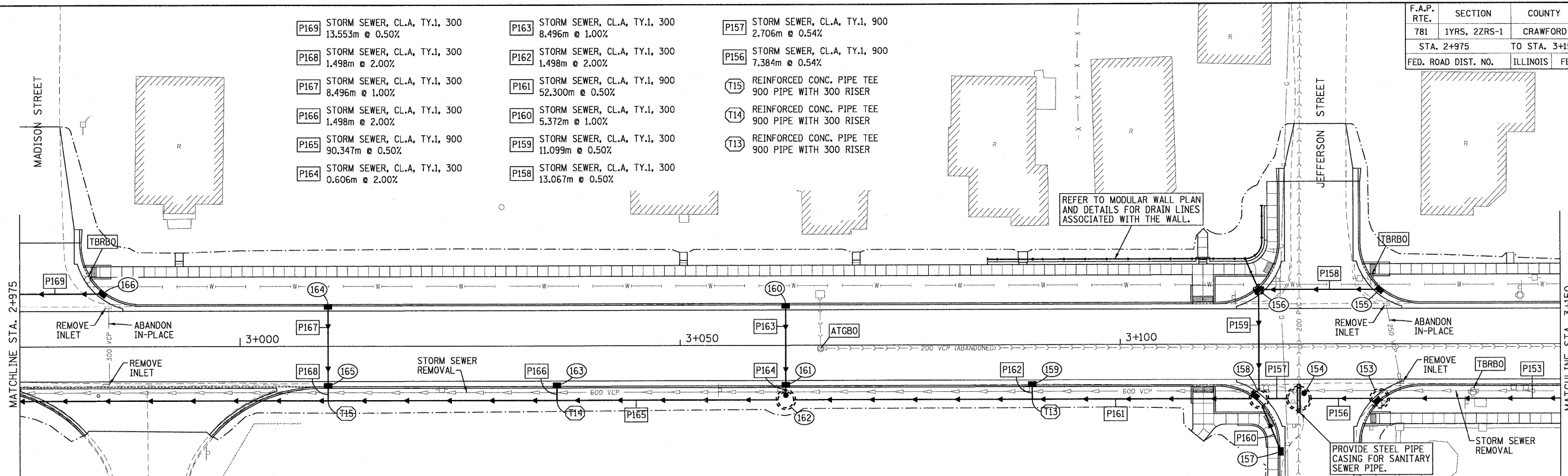

- | | | | |
|---|--|---|---|
| 166 INLET TY.A, TY.3 F&G
STA. 2+984.395, 6.000m LT.
GRATE 153.423
INV. 152.465 | 162 MH. TY.A, RESTRICTED DEPTH
1.8m DIA., TY.1 FRAME, CL. LID
STA. 3+062.000, 6.200m RT.
SEE DETAIL FOR FRAME OFFSET
TOP 154.128
INV.(E,W) 152.188
INV.(N) 152.798 | 158 MH. TY.A, RESTRICTED DEPTH
1.8m DIA., TY.3 F&G
STA. 3+115.748, 6.200m RT.
SEE DETAIL FOR GRATE OFFSET
GRATE 154.117
INV.(E,W) 152.449
INV.(N,S) 153.059 | 155 INLET TY.A, TY.3 F&G
STA. 3+129.452, 6.200m LT.
GRATE 154.151
INV. 153.180 |
| 165 INLET TY.A, TY.3 F&G
STA. 3+010.000, 4.475m RT.
GRATE 153.550
INV. 152.266 | 161 INLET TY.A, TY.3 F&G
STA. 3+062.000, 4.475m RT.
GRATE 153.831
INV. 152.810 | 157 INLET TY.A, TY.3 F&G
STA. 3+118.225, 12.200m RT.
GRATE 154.317
INV. 153.112 | 154 MH. TY.A, RESTRICTED DEPTH
2.4m DIA., TY.1 FRAME, CL. LID
STA. 3+120.261, 6.200m RT.
SEE DETAIL FOR FRAME OFFSET
TOP 154.178
INV.(E,W) 152.464 |
| 164 INLET TY.A, TY.3 F&G
STA. 3+010.000, 4.475m LT.
GRATE 153.550
INV. 152.351 | 160 INLET TY.A, TY.3 F&G
STA. 3+062.000, 4.475m LT.
GRATE 153.831
INV. 152.895 | 156 INLET TY.B, RESTRICTED DEPTH
0.9m DIA., TY.3 F&G
STA. 3+115.748, 6.200m LT.
GRATE 154.140
INV. 153.115 | 153 MH. TY.A, RESTRICTED DEPTH
1.8m DIA., TY.3 F&G
STA. 3+129.452, 6.200m RT.
SEE DETAIL FOR GRATE OFFSET
GRATE 154.182
INV.(E,W) 152.504 |
| 163 INLET TY.A, TY.3 F&G
STA. 3+036.000, 4.475m RT.
GRATE 153.690
INV. 152.396 | 159 INLET TY.A, TY.3 F&G
STA. 3+090.000, 4.475m RT.
GRATE 153.980
INV. 152.658 | | |

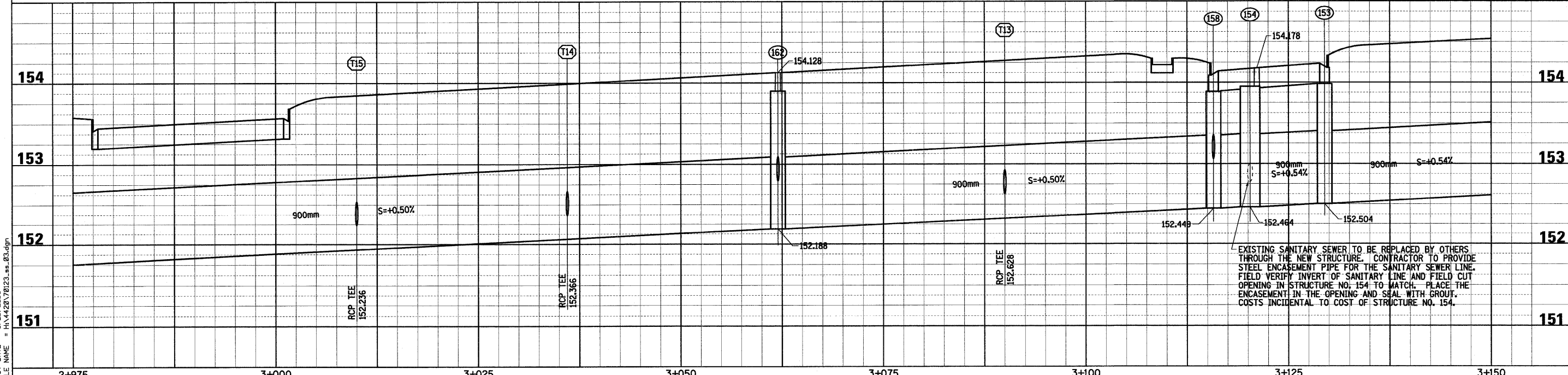
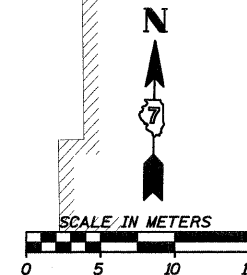

EXISTING SANITARY SEWER TO BE REPLACED BY OTHERS THROUGH THE NEW STRUCTURE. CONTRACTOR TO PROVIDE STEEL ENCASUREMENT PIPE FOR THE SANITARY SEWER LINE. FIELD VERIFY INVERT OF SANITARY LINE AND FIELD CUT OPENING IN STRUCTURE NO. 154 TO MATCH PLACE THE ENCASUREMENT IN THE OPENING AND SEAL WITH GROUT. COSTS INCIDENTAL TO COST OF STRUCTURE NO. 154.

F.A.P. RTE.	SECTION	COUNTY	TOTAL SHEETS	SHEET NO.
781	1YRS, 2ZRS-1	CRAWFORD	378	124
STA. 3+150		TO STA. 3+325		
FED. ROAD DIST. NO.	ILLINOIS		FED. AID PROJECT	

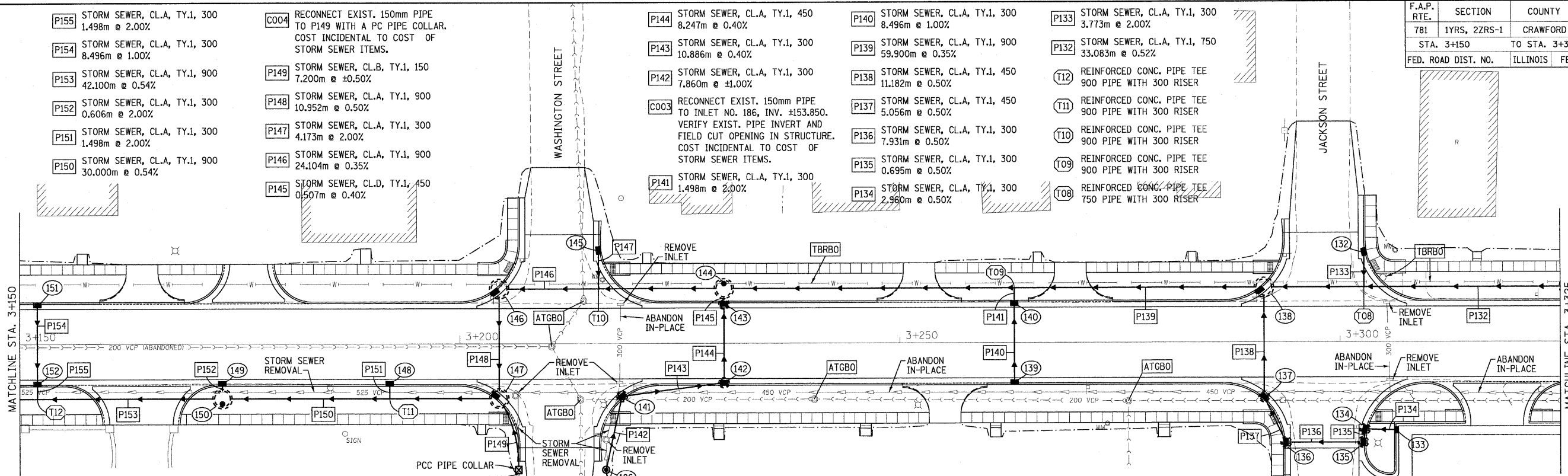

- 152 INLET TY.A, TY.3 F&G
STA. 3+152.000, 4.475m RT.
GRATE 154.303
INV. 152.596
- 151 INLET TY.A, TY.3 F&G
STA. 3+152.000, 4.475m LT.
GRATE 154.303
INV. 153.041
- 150 MH, TY.A, RESTRICTED DEPTH
1.8m DIA., TY.1 FRAME, CL. LID
STA. 3+173.000, 6.200m RT.
SEE DETAIL FOR FRAME OFFSET
TOP 154.660
INV.(E,W) 152.731
INV.(N) 153.341
- 149 INLET TY.A, TY.3 F&G
STA. 3+173.000, 4.475m RT.
GRATE 154.412
INV. 153.353
- 148 INLET TY.A, TY.3 F&G
STA. 3+192.000, 4.475m RT.
GRATE 154.511
INV. 153.164
- 147 MH, TY.A, RESTRICTED DEPTH
1.8m DIA., TY.3 F&G
STA. 3+204.448, 6.200m RT.
SEE DETAIL FOR GRATE OFFSET
GRATE 154.578
INV.(E,N) 152.893
- 146 MH, TY.A, RESTRICTED DEPTH
1.8m DIA., TY.3 F&G
STA. 3+204.448, 6.200m LT.
SEE DETAIL FOR GRATE OFFSET
GRATE 154.577
INV.(E) 153.100
INV.(S) 152.948
- 145 INLET TY.A, TY.3 F&G
STA. 3+215.745, 10.600m LT.
GRATE 154.589
INV. 153.525
- 144 MH, TY.A, RESTRICTED DEPTH
1.8m DIA., TY.1 FRAME, CL. LID
STA. 3+230.000, 6.200m LT.
SEE DETAIL FOR FRAME OFFSET
TOP 154.897
INV.(E,W) 153.185
INV.(S) 153.489
- 143 INLET TY.B, RESTRICTED DEPTH
0.9m DIA., TY.3 F&G
STA. 3+230.000, 4.475m LT.
GRATE 154.708
INV. 153.491
- 142 INLET TY.B, RESTRICTED DEPTH
0.9m DIA., TY.3 F&G
STA. 3+230.000, 4.475m RT.
GRATE 154.708
INV.(S) 153.676
- 141 INLET TY.B, RESTRICTED DEPTH
0.9m DIA., TY.3 F&G
STA. 3+218.395, 6.000m RT.
GRATE 154.621
INV. 153.720
- 186 INLET TY.A, TY.8 GRATE
STA. 3+216.576, 14.300m RT.
TOP 155.000
INV. 153.798
- 140 INLET TY.A, TY.3 F&G
STA. 3+263.000, 4.475m LT.
GRATE 154.880
INV. 153.632
- 139 INLET TY.A, TY.3 F&G
STA. 3+263.000, 4.475m RT.
GRATE 154.880
INV. 153.717
- 138 MH, TY.A, RESTRICTED DEPTH
1.8m DIA., TY.3 F&G
STA. 3+291.348, 6.200m LT.
SEE DETAIL FOR GRATE OFFSET
GRATE 155.028
INV.(E) 153.547
INV.(W) 153.394
INV.(S) 153.699
- 137 INLET TY.B, RESTRICTED DEPTH
0.9m DIA., TY.3 F&G
STA. 3+291.348, 6.200m RT.
GRATE 155.031
INV. 153.755
- 136 INLET TY.B, RESTRICTED DEPTH
0.9m DIA., TY.3 F&G
STA. 3+293.825, 11.400m RT.
GRATE 155.100
INV.(N) 153.932
INV.(E) 153.780
- 135 INLET TY.B, RESTRICTED DEPTH
0.9m DIA., TY.3 F&G
STA. 3+302.575, 11.400m RT.
GRATE 155.100
INV. 153.972
- 134 INLET TY.B, RESTRICTED DEPTH
0.9m DIA., TY.3 F&G
STA. 3+302.780, 9.900m RT.
GRATE 155.068
INV. 153.975
- 133 INLET TY.A, TY.11 F&G
STA. 3+306.375, 10.000m RT.
GRATE 155.348
INV. 153.990
- 132 INLET TY.A, TY.3 F&G
STA. 3+302.713, 10.200m LT.
GRATE 155.069
INV. 153.907

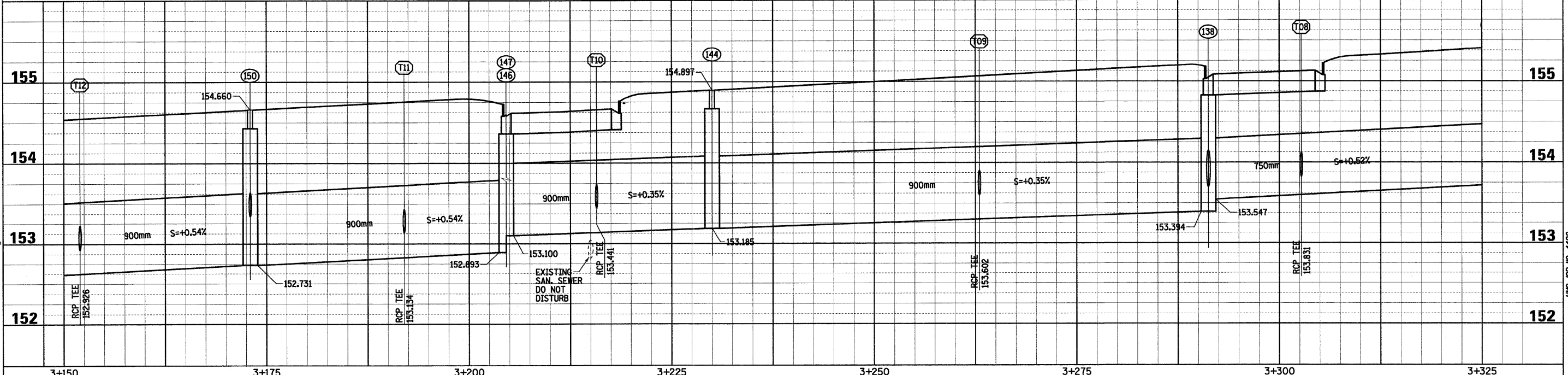
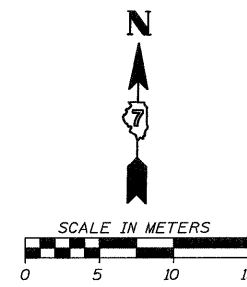

Sheet: 4
Angle: 0.9785
Chain: P_IL33

PLOT DATE = 3/20/2009
FILE NAME = H:\4428\7024_ss_84.dgn

HMG JOB NO. 4420

F.A.P. RTE.	SECTION	COUNTY	TOTAL SHEETS	SHEET NO.
781	1YRS, 2ZRS-1	CRAWFORD	378	125
STA. 3+325		TO STA. 3+500		
FED. ROAD DIST. NO.	ILLINOIS	FED. AID PROJECT		

- P131 STORM SEWER, CL.A, TY.1, 300 0.763m @ 2.00%
- P130 STORM SEWER, CL.A, TY.1, 300 8.496m @ 1.00%
- P129 STORM SEWER, CL.A, TY.1, 300 1.315m @ 2.00%
- P128 STORM SEWER, CL.A, TY.1, 300 9.166m @ 1.00%
- P127 STORM SEWER, CL.A, TY.1, 750 45.431m @ 0.52%
- P126 STORM SEWER, CL.A, TY.1, 300 4.079m @ 1.00%
- P125 STORM SEWER, CL.A, TY.1, 300 12.794m @ 1.00%

- C002 RECONNECT EXIST. 2000 mm PIPE TO INLET NO. 124, INV. ±154.872. VERIFY EXIST. PIPE INVERT AND FIELD CUT OPENING IN STRUCTURE. COST INCIDENTAL TO COST OF STORM SEWER ITEMS.
- P124 STORM SEWER, CL.A, TY.1, 750 9.131m @ 0.52%
- P123 STORM SEWER, CL.A, TY.1, 300 5.873m @ 2.00%

- P122 STORM SEWER, CL.A, TY.1, 300 1.465m @ 2.00%
- P121 STORM SEWER, CL.A, TY.1, 300 0.863m @ 0.50%
- P120 STORM SEWER, CL.A, TY.1, 750 49.266m @ 0.84%
- P119 STORM SEWER, CL.A, TY.1, 300 9.913m @ 1.00%
- P118 STORM SEWER, CL.A, TY.1, 300 0.913m @ 2.00%
- P117 STORM SEWER, CL.A, TY.1, 300 1.648m @ 2.00%
- P116 STORM SEWER, CL.A, TY.1, 300 2.521m @ 2.00%

- P115 STORM SEWER, CL.A, TY.1, 750 43.175m @ 0.84%
- P114 STORM SEWER, CL.A, TY.1, 300 9.913m @ 1.00%
- P113 STORM SEWER, CL.A, TY.1, 300 4.503m @ 1.00%
- P112 STORM SEWER, CL.A, TY.1, 300 1.465m @ 2.00%
- P111 STORM SEWER, CL.A, TY.1, 300 6.130m @ 0.50%
- P110 STORM SEWER, CL.A, TY.1, 300 1.638m @ 0.50%
- P109 STORM SEWER, CL.A, TY.1, 600 43.655m @ 0.60%

- T07 REINFORCED CONC. PIPE TEE 750 PIPE WITH 300 RISER
- T06 REINFORCED CONC. PIPE TEE 750 PIPE WITH 300 RISER
- T05 REINFORCED CONC. PIPE TEE 750 PIPE WITH 300 RISER
- T04 REINFORCED CONC. PIPE TEE 750 PIPE WITH 300 RISER
- T03 REINFORCED CONC. PIPE TEE 600 PIPE WITH 300 RISER

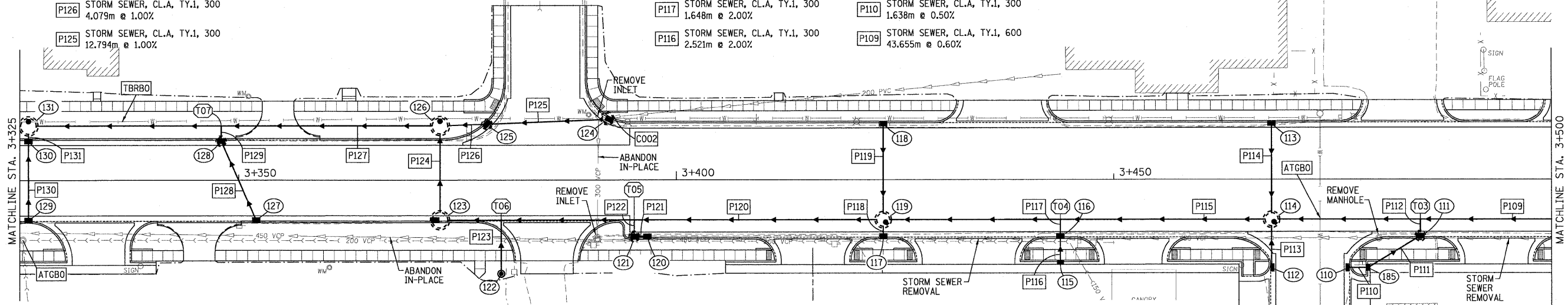

- 131 MH. TY.A, RESTRICTED DEPTH 1.8m DIA., TY.1 FRAME, CL. LID STA. 3+326.000, 6.200m LT. SEE DETAIL FOR FRAME OFFSET TOP 155.410 INV.(E,W) 153.719 INV.(S) 154.176
- 130 INLET TY.A, TY.3 F&G STA. 3+326.000, 4.475m LT. GRATE 155.222 INV. 154.192
- 129 INLET TY.A, TY.3 F&G STA. 3+326.000, 4.475m RT. GRATE 155.222 INV. 154.277
- 128 INLET TY.B, RESTRICTED DEPTH 0.9m DIA., TY.3 F&G STA. 3+348.000, 4.475m LT. GRATE 155.389 INV. 154.084

- 127 INLET TY.A, TY.3 F&G STA. 3+352.000, 4.475m RT. GRATE 155.423 INV. 154.176
- 126 MH. TY.A, RESTRICTED DEPTH 1.8m DIA., TY.1 FRAME, CL. LID STA. 3+373.000, 6.200m LT. SEE DETAIL FOR FRAME OFFSET TOP 155.788 INV.(S,W) 153.955 INV.(E) 154.412
- 125 INLET TY.B, RESTRICTED DEPTH 0.9m DIA., TY.3 F&G STA. 3+378.376, 6.403m LT. GRATE 155.646 INV. 154.453

- 124 MH. TY.A, RESTRICTED DEPTH 1.2m DIA., TY.3 F&G STA. 3+392.139, 7.046m LT. SEE DETAIL FOR GRATE OFFSET GRATE 155.649 INV.(E) ±154.872 INV.(W) 154.580
- 123 MH. TY.A, RESTRICTED DEPTH 1.8m DIA., TY.3 F&G STA. 3+373.000, 4.500m RT. SEE DETAIL FOR GRATE OFFSET GRATE 155.594 INV.(E,N) 154.003
- 122 INLET TY.A, TY.8 GRATE STA. 3+380.000, 10.600m RT. TOP 155.600 INV. 154.400

- 121 INLET TY.B, RESTRICTED DEPTH 0.9m DIA., TY.3 F&G STA. 3+395.200, 6.375m RT. GRATE 155.705 INV. 154.440
- 120 INLET TY.A, TY.3 F&G STA. 3+396.700, 6.375m RT. GRATE 155.721 INV. 154.444
- 119 MH. TY.A, RESTRICTED DEPTH 1.5m DIA., TY.1 FRAME, CL. LID STA. 3+423.650, 4.500m RT. SEE DETAIL FOR FRAME OFFSET TOP 156.024 INV.(E,W) 154.416 INV.(N,S) 154.873
- 118 INLET TY.A, TY.3 F&G STA. 3+423.650, 6.375m LT. GRATE 155.940 INV. 154.973

- 117 INLET TY.A, TY.3 F&G STA. 3+423.650, 6.375m RT. GRATE 155.940 INV. 154.891
- 116 INLET TY.A, TY.3 F&G STA. 3+443.900, 6.375m RT. GRATE 156.099 INV. 154.843
- 115 INLET TY.A, TY.11 F&G STA. 3+443.900, 9.350m RT. GRATE 156.205 INV. 154.893
- 114 MH. TY.A, RESTRICTED DEPTH 1.5m DIA., TY.1 FRAME, CL. LID STA. 3+468.025, 4.500m RT. SEE DETAIL FOR FRAME OFFSET TOP 156.335 INV.(E) 154.931 INV.(W) 154.779 INV.(N,S) 155.236

- 113 INLET TY.A, TY.3 F&G STA. 3+468.025, 6.375m LT. GRATE 156.241 INV. 155.335
- 112 INLET TY.A, TY.3 F&G STA. 3+468.025, 9.965m RT. GRATE 156.193 INV. 155.281
- 111 INLET TY.B, RESTRICTED DEPTH 0.9m DIA., TY.3 F&G STA. 3+485.000, 6.375m RT. GRATE 156.346 INV.(N,S) 155.210
- 105 INLET TY.B, RESTRICTED DEPTH 0.9m DIA., TY.3 F&G STA. 3+479.050, 9.965m RT. GRATE 156.388 INV.(W,N) 155.241

- 110 INLET TY.A, TY.3 F&G STA. 3+476.775, 9.965m RT. GRATE 156.308 INV. 155.249

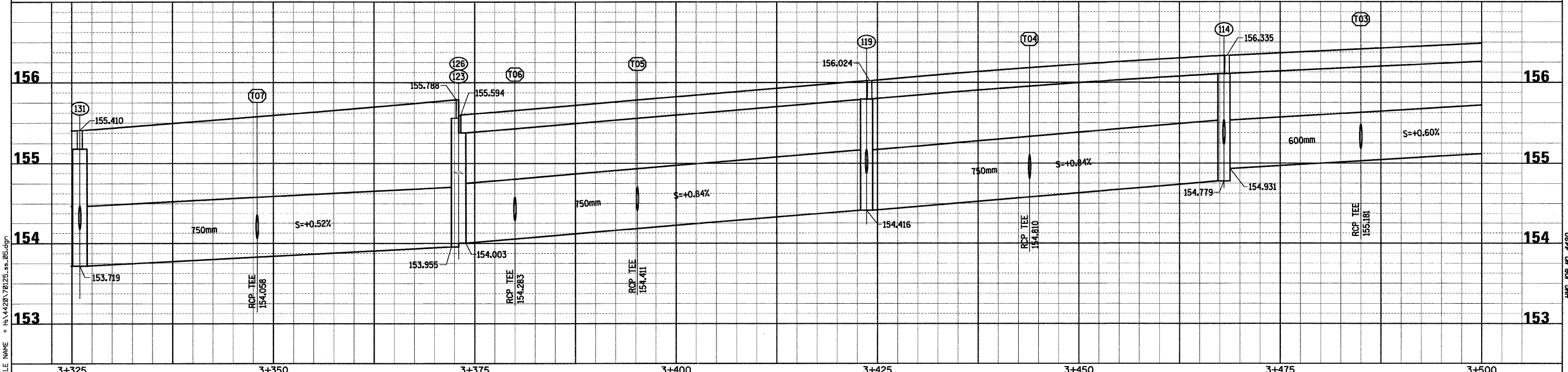
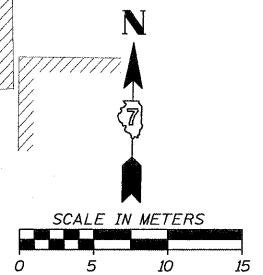

F.A.P. RTE.	SECTION	COUNTY	TOTAL SHEETS	SHEET NO.
781	1YRS, 2ZRS-1	CRAWFORD	378	126
STA. 3+500 TO STA. 3+675				
FED. ROAD DIST. NO.	ILLINOIS	FED. AID PROJECT		

- C001** RECONNECT EXIST. 450mm PIPE TO INLET NO. 100, INV. ±155.950. VERIFY EXIST. PIPE INVERT AND FIELD CUT OPENING IN STRUCTURE. COST INCIDENTAL TO COST OF STORM SEWER ITEMS.
- P100** STORM SEWER, CL.A, TY.1, 450 0.797m @ 1.00%
- P101** STORM SEWER, CL.A, TY.1, 450 6.473m @ 1.00%
- P102** STORM SEWER, CL.A, TY.1, 600 48.614m @ 0.60%
- P103** STORM SEWER, CL.A, TY.1, 300 1.648m @ 2.00%
- P104** STORM SEWER, CL.A, TY.1, 300 1.648m @ 2.00%
- P105** STORM SEWER, CL.A, TY.1, 300 0.913m @ 2.00%
- P106** STORM SEWER, CL.A, TY.1, 300 18.046m @ 0.50%
- P107** STORM SEWER, CL.A, TY.1, 300 17.698m @ 0.50%
- P108** STORM SEWER, CL.A, TY.1, 450 9.636m @ 0.50%
- P109** STORM SEWER, CL.A, TY.1, 600 43.655m @ 0.60%
- T01** REINFORCED CONC. PIPE TEE 600 PIPE WITH 300 RISER
- T02** REINFORCED CONC. PIPE TEE 600 PIPE WITH 300 RISER
- P300** STORM SEWER, CL.A, TY.1, 300 0.863m @ 0.50%
- P301** STORM SEWER, CL.A, TY.1, 300 5.558m @ 0.50%
- P302** STORM SEWER, CL.A, TY.1, 450 9.988m @ 0.50%
- P303** STORM SEWER, CL.A, TY.1, 300 1.073m @ 2.00%
- P304** STORM SEWER, CL.A, TY.1, 600 34.648m @ 1.20%
- P305** STORM SEWER, CL.A, TY.1, 300 10.073m @ 0.50%
- P306** STORM SEWER, CL.A, TY.1, 300 1.073m @ 2.00%
- P307** STORM SEWER, CL.A, TY.1, 600 38.246m @ 1.20%
- P308** STORM SEWER, CL.A, TY.1, 300 1.123m @ 0.50%
- C004** RECONNECT EXIST. 300mm PIPE TO INLET NO. 309, INV. ±154.950. VERIFY EXIST. PIPE INVERT AND FIELD CUT OPENING IN STRUCTURE. COST INCIDENTAL TO COST OF STORM SEWER ITEMS.
- P309** STORM SEWER, CL.A, TY.1, 300 3.847m @ 0.50%
- P310** STORM SEWER, CL.A, TY.1, 300 6.055m @ 1.00%
- P311** STORM SEWER, CL.A, TY.1, 300 9.050m @ 0.50%
- P312** STORM SEWER, CL.A, TY.1, 450 3.847m @ 0.50%
- P313** STORM SEWER, CL.A, TY.1, 600 32.030m @ 0.60%
- P314** STORM SEWER, CL.A, TY.1, 300 1.503m @ 1.00%
- C005** RECONNECT EXIST. 300mm PIPE TO INLET NO. 315, INV. ±154.682. VERIFY EXIST. PIPE INVERT AND FIELD CUT OPENING IN STRUCTURE. COST INCIDENTAL TO COST OF STORM SEWER ITEMS.
- P315** STORM SEWER, CL.A, TY.1, 300 1.648m @ 2.00%
- T30** REINFORCED CONC. PIPE TEE 600 PIPE WITH 300 RISER

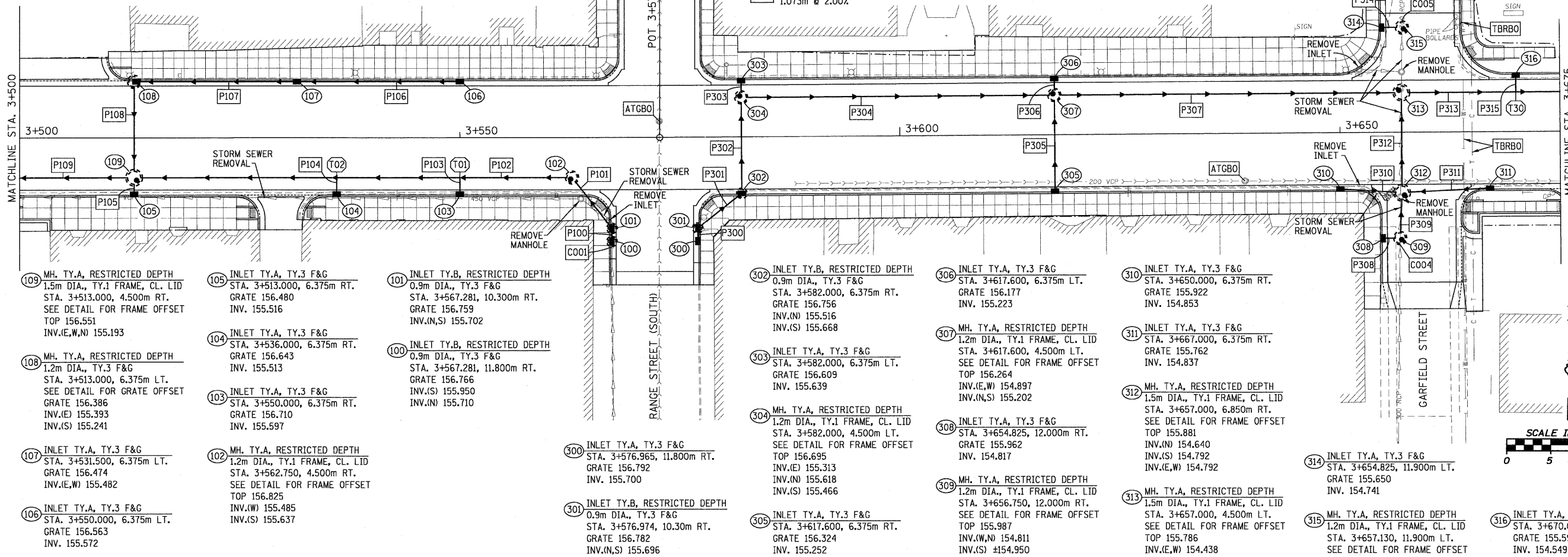

- 109** MH, TY.A, RESTRICTED DEPTH 1.5m DIA., TY.1 FRAME, CL. LID STA. 3+513.000, 4.500m RT. SEE DETAIL FOR FRAME OFFSET TOP 156.551 INV.(E,W,N) 155.193
- 108** MH, TY.A, RESTRICTED DEPTH 1.2m DIA., TY.3 F&G STA. 3+513.000, 6.375m LT. SEE DETAIL FOR GRATE OFFSET GRATE 156.386 INV.(E) 155.393 INV.(S) 155.241
- 107** INLET TY.A, TY.3 F&G STA. 3+531.500, 6.375m LT. GRATE 156.474 INV.(E,W) 155.482
- 106** INLET TY.A, TY.3 F&G STA. 3+550.000, 6.375m LT. GRATE 156.563 INV. 155.572
- 105** INLET TY.A, TY.3 F&G STA. 3+513.000, 6.375m RT. GRATE 156.480 INV. 155.516
- 104** INLET TY.A, TY.3 F&G STA. 3+536.000, 6.375m RT. GRATE 156.643 INV. 155.513
- 103** INLET TY.A, TY.3 F&G STA. 3+550.000, 6.375m RT. GRATE 156.710 INV. 155.597
- 102** MH, TY.A, RESTRICTED DEPTH 1.2m DIA., TY.1 FRAME, CL. LID STA. 3+562.750, 4.500m RT. SEE DETAIL FOR FRAME OFFSET TOP 156.825 INV.(W) 155.485 INV.(S) 155.637
- 101** INLET TY.B, RESTRICTED DEPTH 0.9m DIA., TY.3 F&G STA. 3+567.281, 10.300m RT. GRATE 156.759 INV.(N,S) 155.702
- 100** INLET TY.B, RESTRICTED DEPTH 0.9m DIA., TY.3 F&G STA. 3+567.281, 11.800m RT. GRATE 156.766 INV.(S) 155.950 INV.(N) 155.710
- 300** INLET TY.A, TY.3 F&G STA. 3+576.965, 11.800m RT. GRATE 156.792 INV. 155.700
- 301** INLET TY.B, RESTRICTED DEPTH 0.9m DIA., TY.3 F&G STA. 3+576.974, 10.30m RT. GRATE 156.782 INV.(N,S) 155.696
- 302** INLET TY.B, RESTRICTED DEPTH 0.9m DIA., TY.3 F&G STA. 3+582.000, 6.375m RT. GRATE 156.756 INV.(N) 155.516 INV.(S) 155.668
- 303** INLET TY.A, TY.3 F&G STA. 3+582.000, 6.375m LT. GRATE 156.609 INV. 155.639
- 304** MH, TY.A, RESTRICTED DEPTH 1.2m DIA., TY.1 FRAME, CL. LID STA. 3+582.000, 4.500m LT. SEE DETAIL FOR FRAME OFFSET TOP 156.695 INV.(E) 155.313 INV.(N) 155.618 INV.(S) 155.466
- 305** INLET TY.A, TY.3 F&G STA. 3+617.600, 6.375m RT. GRATE 156.324 INV. 155.252
- 306** INLET TY.A, TY.3 F&G STA. 3+617.600, 6.375m LT. GRATE 156.177 INV. 155.223
- 307** MH, TY.A, RESTRICTED DEPTH 1.2m DIA., TY.1 FRAME, CL. LID STA. 3+617.600, 4.500m LT. SEE DETAIL FOR FRAME OFFSET TOP 156.264 INV.(E,W) 154.897 INV.(N,S) 155.202
- 308** INLET TY.A, TY.3 F&G STA. 3+654.825, 12.000m RT. GRATE 155.962 INV. 154.817
- 309** MH, TY.A, RESTRICTED DEPTH 1.2m DIA., TY.1 FRAME, CL. LID STA. 3+656.750, 12.000m RT. SEE DETAIL FOR FRAME OFFSET TOP 155.987 INV.(W,N) 154.811 INV.(S) ±154.950
- 310** INLET TY.A, TY.3 F&G STA. 3+650.000, 6.375m RT. GRATE 155.922 INV. 154.853
- 311** INLET TY.A, TY.3 F&G STA. 3+667.000, 6.375m RT. GRATE 155.762 INV. 154.837
- 312** MH, TY.A, RESTRICTED DEPTH 1.5m DIA., TY.1 FRAME, CL. LID STA. 3+657.000, 6.850m RT. SEE DETAIL FOR FRAME OFFSET TOP 155.881 INV.(N) 154.640 INV.(S) 154.792 INV.(E,W) 154.792
- 313** MH, TY.A, RESTRICTED DEPTH 1.5m DIA., TY.1 FRAME, CL. LID STA. 3+657.000, 4.500m LT. SEE DETAIL FOR FRAME OFFSET TOP 155.786 INV.(E,W) 154.438 INV.(S) 154.590
- 314** INLET TY.A, TY.3 F&G STA. 3+654.825, 11.900m LT. GRATE 155.650 INV. 154.741
- 315** MH, TY.A, RESTRICTED DEPTH 1.2m DIA., TY.1 FRAME, CL. LID STA. 3+657.130, 11.900m LT. SEE DETAIL FOR FRAME OFFSET TOP 155.708 INV.(W) 154.726 INV.(N) ±154.682
- 316** INLET TY.A, TY.3 F&G STA. 3+670.000, 6.375m LT. GRATE 155.591 INV. 154.549

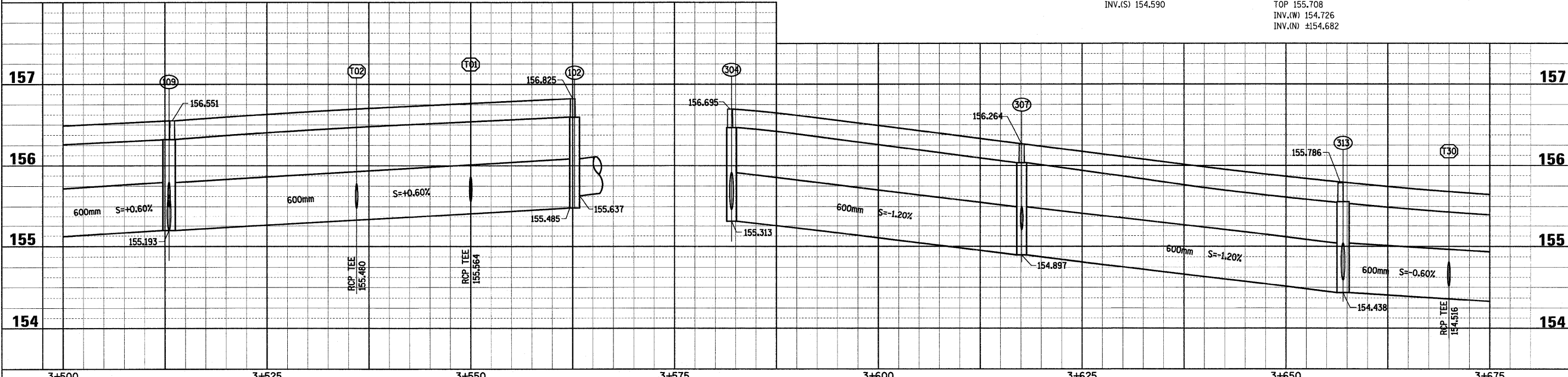
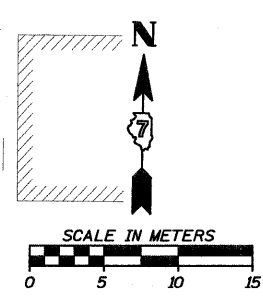

F.A.P. RTE.	SECTION	COUNTY	TOTAL SHEETS	SHEET NO.
781	1YRS, 2ZRS-1	CRAWFORD	378	127
STA. 3+675 TO STA. 3+850				
FED. ROAD DIST. NO.	ILLINOIS	FED. AID PROJECT		

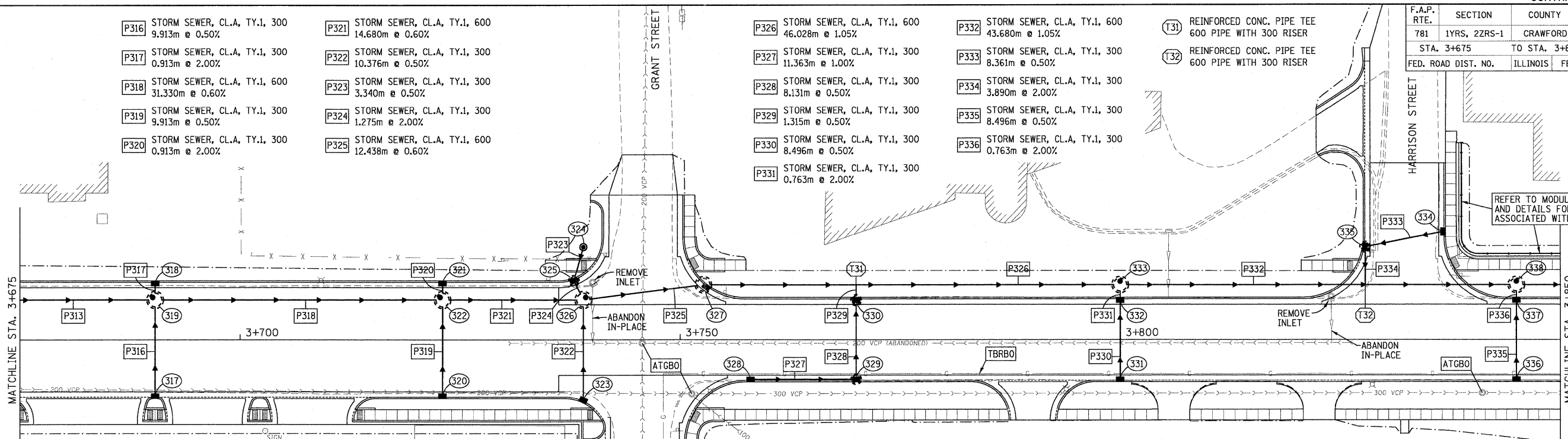

- P316** STORM SEWER, CL.A, TY.1, 300 9.913m @ 0.50%
 - P317** STORM SEWER, CL.A, TY.1, 300 0.913m @ 2.00%
 - P318** STORM SEWER, CL.A, TY.1, 600 31.330m @ 0.60%
 - P319** STORM SEWER, CL.A, TY.1, 300 9.913m @ 0.50%
 - P320** STORM SEWER, CL.A, TY.1, 300 0.913m @ 2.00%
 - P321** STORM SEWER, CL.A, TY.1, 600 14.680m @ 0.60%
 - P322** STORM SEWER, CL.A, TY.1, 300 10.376m @ 0.50%
 - P323** STORM SEWER, CL.A, TY.1, 300 3.340m @ 0.50%
 - P324** STORM SEWER, CL.A, TY.1, 300 1.275m @ 2.00%
 - P325** STORM SEWER, CL.A, TY.1, 600 12.438m @ 0.60%
 - P326** STORM SEWER, CL.A, TY.1, 600 46.028m @ 1.05%
 - P327** STORM SEWER, CL.A, TY.1, 300 11.363m @ 1.00%
 - P328** STORM SEWER, CL.A, TY.1, 300 8.131m @ 0.50%
 - P329** STORM SEWER, CL.A, TY.1, 300 1.315m @ 0.50%
 - P330** STORM SEWER, CL.A, TY.1, 300 8.496m @ 0.50%
 - P331** STORM SEWER, CL.A, TY.1, 300 0.763m @ 2.00%
 - P332** STORM SEWER, CL.A, TY.1, 600 43.680m @ 1.05%
 - P333** STORM SEWER, CL.A, TY.1, 300 8.361m @ 0.50%
 - P334** STORM SEWER, CL.A, TY.1, 300 3.890m @ 2.00%
 - P335** STORM SEWER, CL.A, TY.1, 300 8.496m @ 0.50%
 - P336** STORM SEWER, CL.A, TY.1, 300 0.763m @ 2.00%
- (T31)** REINFORCED CONC. PIPE TEE 600 PIPE WITH 300 RISER
 - (T32)** REINFORCED CONC. PIPE TEE 600 PIPE WITH 300 RISER
- 317** INLET TY.A, TY.3 F&G STA. 3+690.350, 6.375m RT. GRATE 155.593 INV. 154.601
 - 318** INLET TY.A, TY.3 F&G STA. 3+690.350, 6.375m LT. GRATE 155.486 INV. 154.569
 - 319** MH, TY.A, RESTRICTED DEPTH 1.5m DIA., TY.1 FRAME, CL. LID STA. 3+690.350, 4.500m LT. SEE DETAIL FOR FRAME OFFSET TOP 155.568 INV.(E,W) 154.246 INV.(N,S) 154.551
 - 320** INLET TY.A, TY.3 F&G STA. 3+723.000, 6.375m RT. GRATE 155.346 INV. 154.413
 - 321** INLET TY.A, TY.3 F&G STA. 3+723.000, 6.375m LT. GRATE 155.340 INV. 154.381
 - 322** MH, TY.A, RESTRICTED DEPTH 1.5m DIA., TY.1 FRAME, CL. LID STA. 3+723.000, 4.500m LT. SEE DETAIL FOR FRAME OFFSET TOP 155.422 INV.(E,W) 154.058 INV.(N,S) 154.363
 - 323** INLET TY.A, TY.3 F&G STA. 3+739.000, 6.838m RT. GRATE 155.251 INV. 154.327
 - 324** INLET TY.A, TY.8 GRADE STA. 3+739.000, 10.500m LT. GRATE 155.365 INV. 154.317
 - 325** INLET TY.B, RESTRICTED DEPTH 0.9m DIA., TY.3 F&G STA. 3+737.930, 6.670m LT. GRATE 155.266 INV.(N,S) 154.300
 - 326** MH, TY.A, RESTRICTED DEPTH 1.5m DIA., TY.1 FRAME, CL. LID STA. 3+739.000, 4.500m LT. SEE DETAIL FOR FRAME OFFSET TOP 155.341 INV.(E,W) 153.970 INV.(N,S) 154.275
 - 327** MH, TY.A, RESTRICTED DEPTH 1.5m DIA., TY.3 F&G STA. 3+752.652, 6.200m LT. SEE DETAIL FOR GRATE OFFSET GRATE 155.265 INV.(E,W) 153.895
 - 328** INLET TY.A, TY.3 F&G STA. 3+758.000, 4.475m RT. GRATE 155.209 INV. 154.033
 - 329** INLET TY.B, RESTRICTED DEPTH 0.9m DIA., TY.3 F&G STA. 3+770.000, 4.475m RT. GRATE 155.092 INV.(W,N) 153.919
 - 330** INLET TY.B, RESTRICTED DEPTH 0.9m DIA., TY.3 F&G STA. 3+770.000, 4.475m LT. GRATE 155.092 INV.(N,S) 153.879
 - 331** INLET TY.A, TY.3 F&G STA. 3+800.000, 4.475m RT. GRATE 154.710 INV. 153.775
 - 332** INLET TY.A, TY.3 F&G STA. 3+800.000, 4.475m LT. GRATE 154.710 INV. 153.732
 - 333** MH, TY.A, RESTRICTED DEPTH 1.5m DIA., TY.1 FRAME, CL. LID STA. 3+800.000, 6.200m LT. SEE DETAIL FOR FRAME OFFSET TOP 155.006 INV.(E,W) 153.412 INV.(S) 153.717
 - 334** INLET TY.A, TY.3 F&G STA. 3+836.675, 12.200m LT. GRATE 154.376 INV. 153.399
 - 335** INLET TY.B, RESTRICTED DEPTH 0.9m DIA., TY.3 F&G STA. 3+827.839, 10.500m LT. GRATE 154.340 INV.(E,S) 153.357
 - 336** INLET TY.A, TY.3 F&G STA. 3+845.000, 4.475m RT. GRATE 154.125 INV. 153.315
 - 337** INLET TY.A, TY.3 F&G STA. 3+845.000, 4.475m LT. GRATE 154.125 INV. 153.273
 - 338** MH, TY.A, RESTRICTED DEPTH 1.5m DIA., TY.1 FRAME, CL. LID STA. 3+845.000, 6.200m LT. SEE DETAIL FOR FRAME OFFSET TOP 154.322 INV.(E,W) 152.953 INV.(S) 153.258

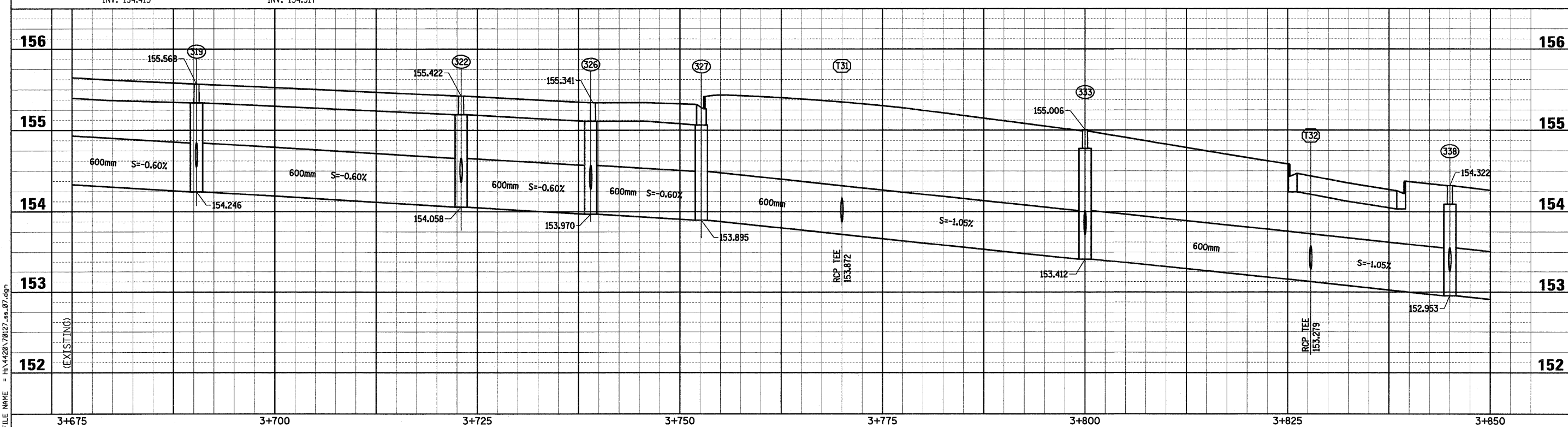
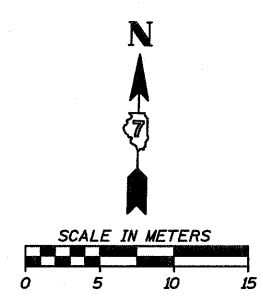

Sheet: 7
Angle: 1.3348
Chain: P_IL33

PLOT DATE = 3/28/2009
FILE NAME = H:\1428\78127_m_07.dgn

HMG JOB NO. 4420

F.A.P. RTE.	SECTION	COUNTY	TOTAL SHEETS	SHEET NO.
781	1YRS, 2ZRS-1	CRAWFORD	378	128
STA. 3+850		TO STA. 4+025		
FED. ROAD DIST. NO.		ILLINOIS	FED. AID PROJECT	

- P337 STORM SEWER, CL.A, TY.1, 600 29.680m @ 1.05%
- P338 STORM SEWER, CL.A, TY.1, 300 8.496m @ 0.50%
- P339 STORM SEWER, CL.A, TY.1, 300 0.763m @ 2.00%
- P340 STORM SEWER, CL.A, TY.1, 600 22.996m @ 1.05%
- P341 STORM SEWER, CL.A, TY.1, 300 4.081m @ 0.50%
- C006 RECONNECT EXIST. DOUBLE BARREL 450mm PIPE TO INLET NO. 344, INV. ±152.604. VERIFY EXIST. PIPE INVERTS AND FIELD CUT OPENING IN STRUCTURE. COST INCIDENTAL TO COST OF STORM SEWER ITEMS.
- P342 STORM SEWER, CL.A, TY.1, 450 DOUBLE BARREL PIPES 9.872m EACH @ 0.50%
- P343 STORM SEWER, CL.A, TY.1, 300 4.123m @ 0.50%
- P344 STORM SEWER, CL.A, TY.1, 300 3.523m @ 0.50%
- P345 STORM SEWER, CL.A, TY.1, 300 7.109m @ 0.50%
- P346 STORM SEWER, CL.A, TY.1, 300 8.131m @ 0.40%
- P347 STORM SEWER, CL.A, TY.1, 300 0.553m @ 0.40%
- P348 STORM SEWER, CL.A, TY.1, 300 0.863m @ 0.50%
- P349 STORM SEWER, CL.A, TY.1, 300 8.131m @ 0.40%
- P350 STORM SEWER, CL.A, TY.1, 300 0.863m @ 0.50%
- P351 STORM SEWER, CL.A, TY.1, 300 0.553m @ 0.40%

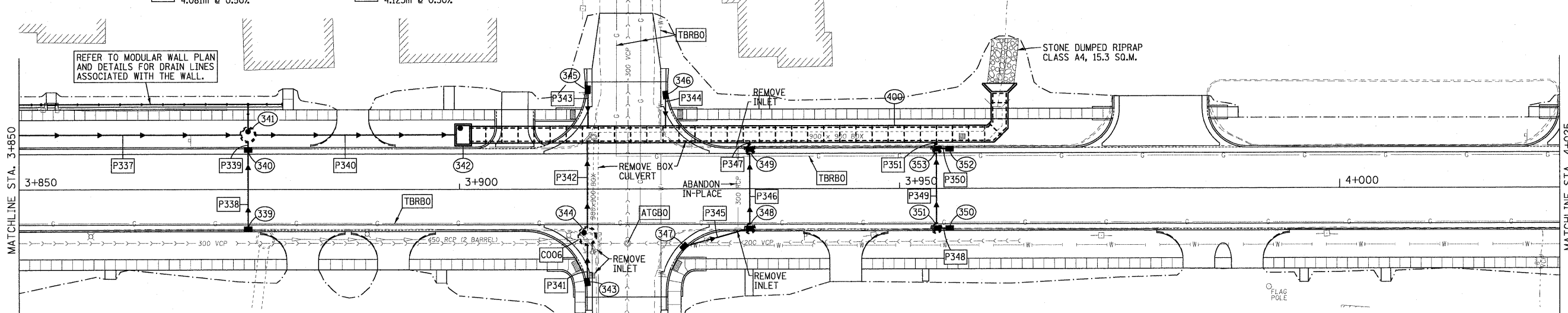

- 339 INLET TY.A, TY.3 F&G STA. 3+876.000, 4.475m RT. GRATE 153.731 INV. 152.852
- 340 INLET TY.A, TY.3 F&G STA. 3+876.000, 4.475m LT. GRATE 153.731 INV. 152.810
- 341 MH. TY.A, RESTRICTED DEPTH 1.5m DIA., TY.1 FRAME, CL. LID STA. 3+876.000, 6.200m LT. SEE DETAIL FOR FRAME OFFSET TOP 153.954 INV.(E,W) 152.642 INV.(S) 152.794
- 342 JUNCTION BOX NO. 1 STA. 3+900.418, 6.200m LT. SEE JUNCTION BOX DETAIL SHEET TOP 153.788 INV. 152.400
- 343 INLET TY.A, TY.3 F&G STA. 3+914.540, 10.500m RT. GRATE 153.448 INV. 152.443
- 344 MH. TY.A, RESTRICTED DEPTH 1.8m DIA., TY.1 FRAME, CL. LID STA. 3+914.540, 5.300m RT. SEE DETAIL FOR FRAME OFFSET TOP 153.501 INV.(N,S) 152.422 INV.(W) ±152.604
- 345 INLET TY.A, TY.3 F&G STA. 3+914.619, 11.300m LT. GRATE 153.309 INV. 152.532
- 346 INLET TY.A, TY.3 F&G STA. 3+923.432, 10.700m LT. GRATE 153.307 INV. 152.504
- 347 INLET TY.A, TY.3 F&G STA. 3+925.524, 6.500m RT. GRATE 153.366 INV. 152.527
- 348 INLET TY.B, RESTRICTED DEPTH 0.9m DIA., TY.3 F&G STA. 3+933.000, 4.475m RT. GRATE 153.387 INV.(W,N) 152.492
- 349 INLET TY.B, RESTRICTED DEPTH 0.9m DIA., TY.3 F&G STA. 3+933.000, 4.475m LT. GRATE 153.387 INV.(N,S) 152.459
- 350 INLET TY.A, TY.3 F&G STA. 3+955.700, 4.475m RT. GRATE 153.335 INV. 152.432
- 351 INLET TY.B, RESTRICTED DEPTH 0.9m DIA., TY.3 F&G STA. 3+954.200, 4.475m RT. GRATE 153.335 INV.(E,N) 152.427
- 352 INLET TY.A, TY.3 F&G STA. 3+955.700, 4.475m LT. GRATE 153.335 INV. 152.399
- 353 INLET TY.B, RESTRICTED DEPTH 0.9m DIA., TY.3 F&G STA. 3+954.200, 4.475m LT. GRATE 153.335 INV.(E,N,S) 152.395
- 400 BOX CULVERT NO. 7, R.C.B.C. 1.5m x 0.6m BEGIN STA. 3+901.180, 6.200m LT. END STA. 3+961.400, 11.000m LT. PROVIDE TWO 45° BENDS AS SHOWN (1) R.C.B.C. END SECTION, 1.5m x 0.6m U.S.F.L. 152.400 D.S.F.L. 152.207

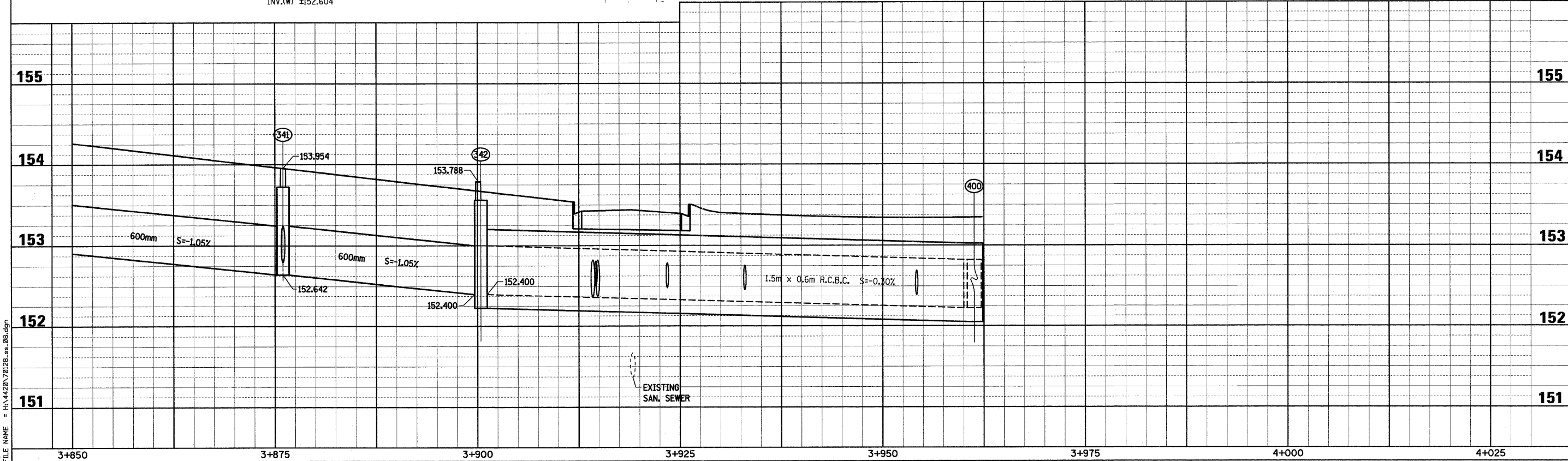
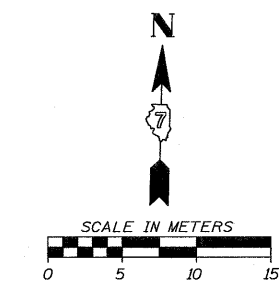

Sheet: 8
Angle: 1.3344
Chain: P_IL33

PLOT DATE = 3/26/2008
FILE NAME = H:\1420\170128.sn_08.dgn

HMG JOB NO. 4420

F.A.P. RTE.	SECTION	COUNTY	TOTAL SHEETS	SHEET NO.
781	1YRS, 2ZRS-1	CRAWFORD	378	129
STA. 4+025		TO STA. 4+200		
FED. ROAD DIST. NO.	ILLINOIS	FED. AID PROJECT		

- P500 STORM SEWER, CL.A, TY.1, 300 8.496m @ 0.50%
- P501 STORM SEWER, CL.A, TY.1, 300 0.923m @ 0.50%
- P502 STORM SEWER, CL.A, TY.1, 450 108.763m @ 0.40%
- P503 STORM SEWER, CL.A, TY.1, 300 8.496m @ 0.50%
- P504 STORM SEWER, CL.A, TY.1, 300 1.498m @ 2.00%
- P505 STORM SEWER, CL.A, TY.1, 300 8.496m @ 0.50%
- P506 STORM SEWER, CL.A, TY.1, 300 1.498m @ 2.00%
- P507 STORM SEWER, CL.A, TY.1, 300 1.065m @ 1.00%
- P508 STORM SEWER, CL.A, TY.1, 450 16.466m @ 0.40%
- P509 STORM SEWER, CL.A, TY.1, 300 9.610m @ 0.50%
- P510 STORM SEWER, CL.A, TY.1, 300 6.981m @ 0.50%
- P511 STORM SEWER, CL.A, TY.1, 300 8.806m @ 0.50%
- P512 STORM SEWER, CL.A, TY.1, 600 60.815m @ 1.00%
- P513 STORM SEWER, CL.A, TY.1, 300 8.496m @ 0.50%
- P514 STORM SEWER, CL.A, TY.1, 300 1.498m @ 2.00%
- T50 REINFORCED CONC. PIPE TEE 450 PIPE WITH 300 RISER
- T51 REINFORCED CONC. PIPE TEE 450 PIPE WITH 300 RISER
- T52 REINFORCED CONC. PIPE TEE 600 PIPE WITH 300 RISER

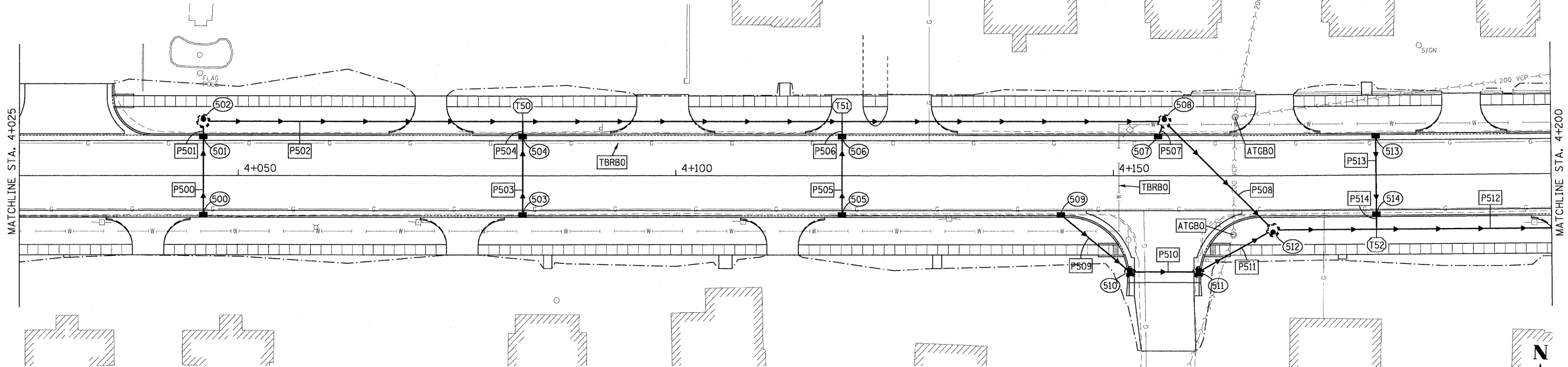

- 500 INLET TY.A, TY.3 F&G STA. 4+046.000, 4.475m RT. GRATE 153.386 INV. 152.400
- 501 INLET TY.A, TY.3 F&G STA. 4+046.000, 4.475m LT. GRATE 153.386 INV. 152.358
- 502 MH, TY.A, RESTRICTED DEPTH 1.2m DIA., TY.1 FRAME, CL. LID STA. 4+046.000, 6.200m LT. SEE DETAIL FOR FRAME OFFSET TOP 153.570 INV.(E) 152.201 INV.(S) 152.353
- 503 INLET TY.A, TY.3 F&G STA. 4+082.500, 4.475m RT. GRATE 153.284 INV. 152.206
- 504 INLET TY.A, TY.3 F&G STA. 4+082.500, 4.475m LT. GRATE 153.284 INV. 152.163
- 505 INLET TY.A, TY.3 F&G STA. 4+119.000, 4.475m RT. GRATE 153.182 INV. 152.060
- 506 INLET TY.A, TY.3 F&G STA. 4+119.000, 4.475m LT. GRATE 153.182 INV. 152.017
- 507 INLET TY.A, TY.3 F&G STA. 4+155.118, 4.475m LT. GRATE 153.024 INV. 151.928
- 508 MH, TY.A, RESTRICTED DEPTH 1.2m DIA., TY.1 FRAME, CL. LID STA. 4+155.833, 6.200m LT. SEE DETAIL FOR FRAME OFFSET TOP 153.235 INV.(W,SE) 151.765 INV.(S,W) 151.917
- 509 INLET TY.A, TY.3 F&G STA. 4+144.000, 4.475m RT. GRATE 153.094 INV. 151.979
- 510 INLET TY.B, RESTRICTED DEPTH 0.9m DIA., TY.3 F&G STA. 4+151.900, 11.000m RT. GRATE 152.887 INV.(NW,E) 151.931
- 511 INLET TY.B, RESTRICTED DEPTH 0.9m DIA., TY.3 F&G STA. 4+159.700, 11.000m RT. GRATE 152.885 INV.(W,NE) 151.896
- 512 MH, TY.A, RESTRICTED DEPTH 1.2m DIA., TY.1 FRAME, CL. LID STA. 4+168.233, 6.200m RT. SEE DETAIL FOR FRAME OFFSET TOP 153.096 INV.(NW) 151.700 INV.(E) 151.547 INV.(SW) 151.852
- 513 INLET TY.A, TY.3 F&G STA. 4+180.000, 4.475m LT. GRATE 152.795 INV. 151.658
- 514 INLET TY.A, TY.3 F&G STA. 4+180.000, 4.475m RT. GRATE 152.795 INV. 151.616

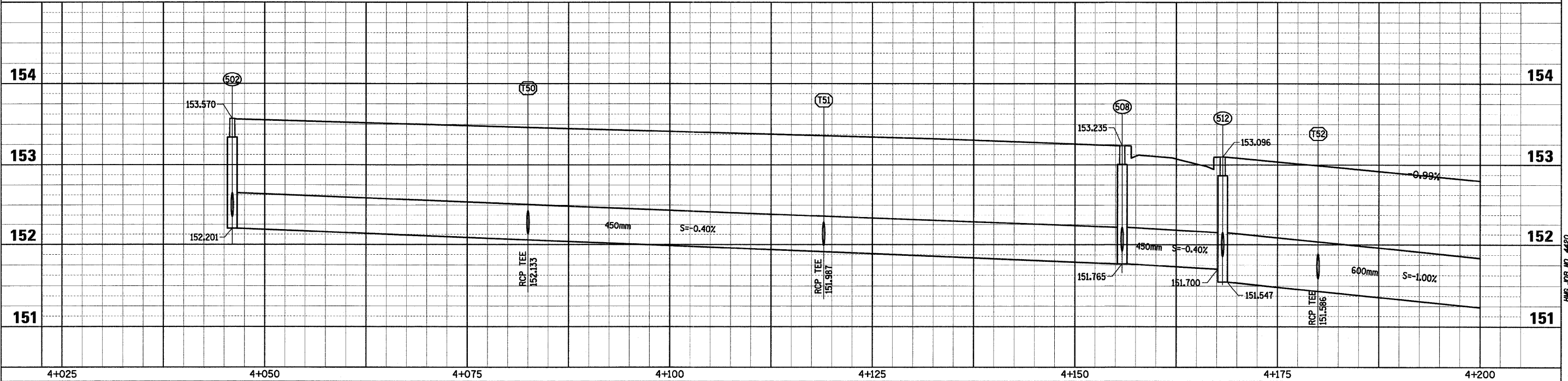
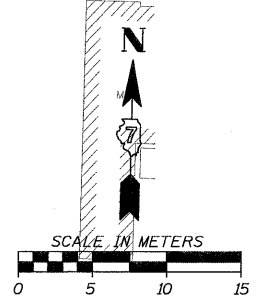

Sheet: 9
 Angle: 1.3348
 Chain: P_IL33

PLOT DATE = 3/29/2009
 FILE NAME = H:\428\78129_ss_09.dgn

HMG JOB NO. 4460

F.A.P. RTE.	SECTION	COUNTY	TOTAL SHEETS	SHEET NO.
781	1YRS, 2ZRS-1	CRAWFORD	378	130
STA. 4+200		TO STA. 4+375		
FED. ROAD DIST. NO.		ILLINOIS FED. AID PROJECT		

- P515 STORM SEWER, CL.A, TY.1, 300 8.496m @ 0.50%
- P516 STORM SEWER, CL.A, TY.1, 300 0.923m @ 1.00%
- P517 STORM SEWER, CL.A, TY.1, 600 84.601m @ 1.15%
- P518 STORM SEWER, CL.A, TY.1, 300 1.498m @ 2.00%
- P519 STORM SEWER, CL.A, TY.1, 300 19.100m @ 0.50%
- P520 STORM SEWER, CL.A, TY.1, 300 8.131m @ 0.50%
- P521 STORM SEWER, CL.A, TY.1, 300 0.581m @ 1.00%
- P522 STORM SEWER, CL.A, TY.1, 600 48.825m @ 1.15%
- P523 STORM SEWER, CL.A, TY.1, 300 8.496m @ 0.50%
- P524 STORM SEWER, CL.A, TY.1, 300 0.763m @ 1.00%
- P525 STORM SEWER, CL.A, TY.1, 600 42.438m @ 0.60%
- T53 REINFORCED CONC. PIPE TEE 600 PIPE WITH 300 RISER

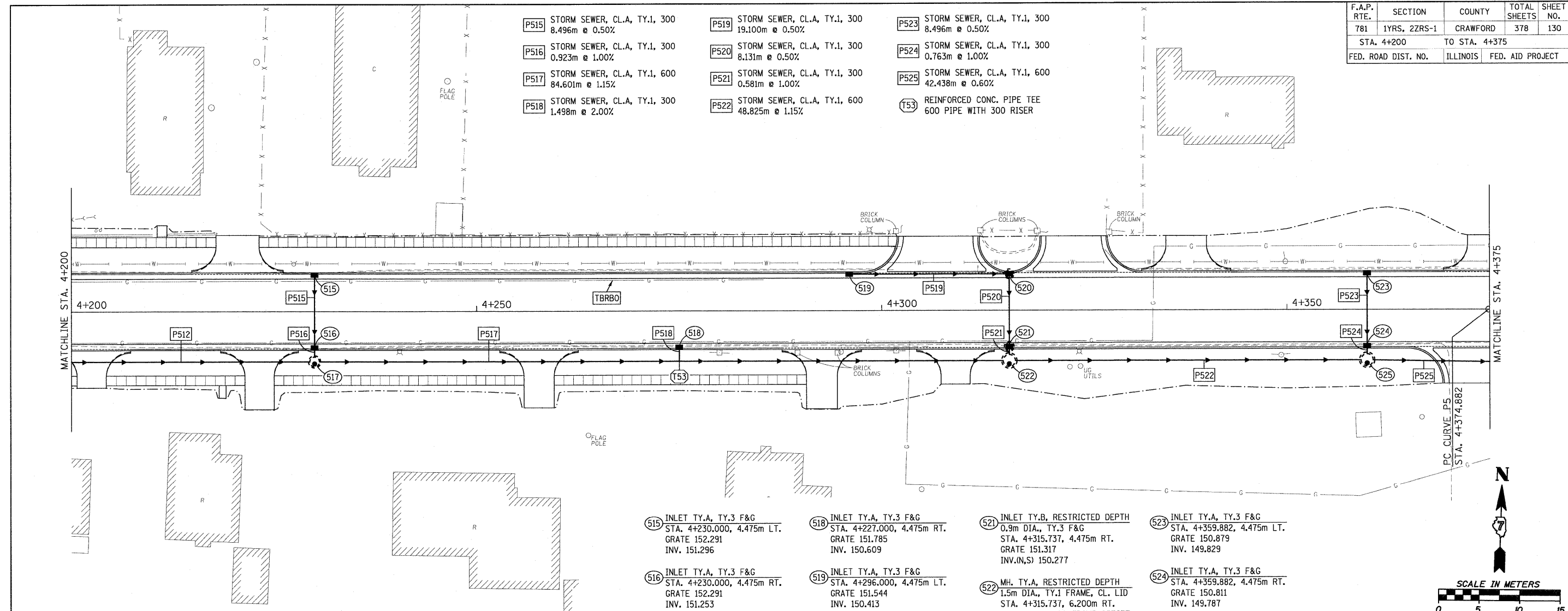

- 515 INLET TY.A, TY.3 F&G STA. 4+230.000, 4.475m LT. GRATE 152.291 INV. 151.296
- 516 INLET TY.A, TY.3 F&G STA. 4+230.000, 4.475m RT. GRATE 152.291 INV. 151.253
- 517 MH. TY.A, RESTRICTED DEPTH 1.2m DIA., TY.1 FRAME, CL. LID STA. 4+230.000, 6.200m RT. SEE DETAIL FOR FRAME OFFSET TOP 152.524 INV.(E,W) 150.939 INV.(N) 151.244
- 518 INLET TY.A, TY.3 F&G STA. 4+227.000, 4.475m RT. GRATE 151.785 INV. 150.609
- 519 INLET TY.A, TY.3 F&G STA. 4+296.000, 4.475m LT. GRATE 151.544 INV. 150.413
- 520 INLET TY.B, RESTRICTED DEPTH 0.9m DIA., TY.3 F&G STA. 4+315.737, 4.475m LT. GRATE 151.317 INV.(W,S) 150.317
- 521 INLET TY.B, RESTRICTED DEPTH 0.9m DIA., TY.3 F&G STA. 4+315.737, 4.475m RT. GRATE 151.317 INV.(N,S) 150.277
- 522 MH. TY.A, RESTRICTED DEPTH 1.5m DIA., TY.1 FRAME, CL. LID STA. 4+315.737, 6.200m RT. SEE DETAIL FOR FRAME OFFSET TOP 151.500 INV.(E,W) 149.966 INV.(N) 150.271
- 523 INLET TY.A, TY.3 F&G STA. 4+359.882, 4.475m LT. GRATE 150.879 INV. 149.829
- 524 INLET TY.A, TY.3 F&G STA. 4+359.882, 4.475m RT. GRATE 150.811 INV. 149.787
- 525 MH. TY.A, RESTRICTED DEPTH 1.5m DIA., TY.1 FRAME, CL. LID STA. 4+359.882, 6.200m RT. SEE DETAIL FOR FRAME OFFSET TOP 150.997 INV.(E,W) 149.474 INV.(N) 149.779

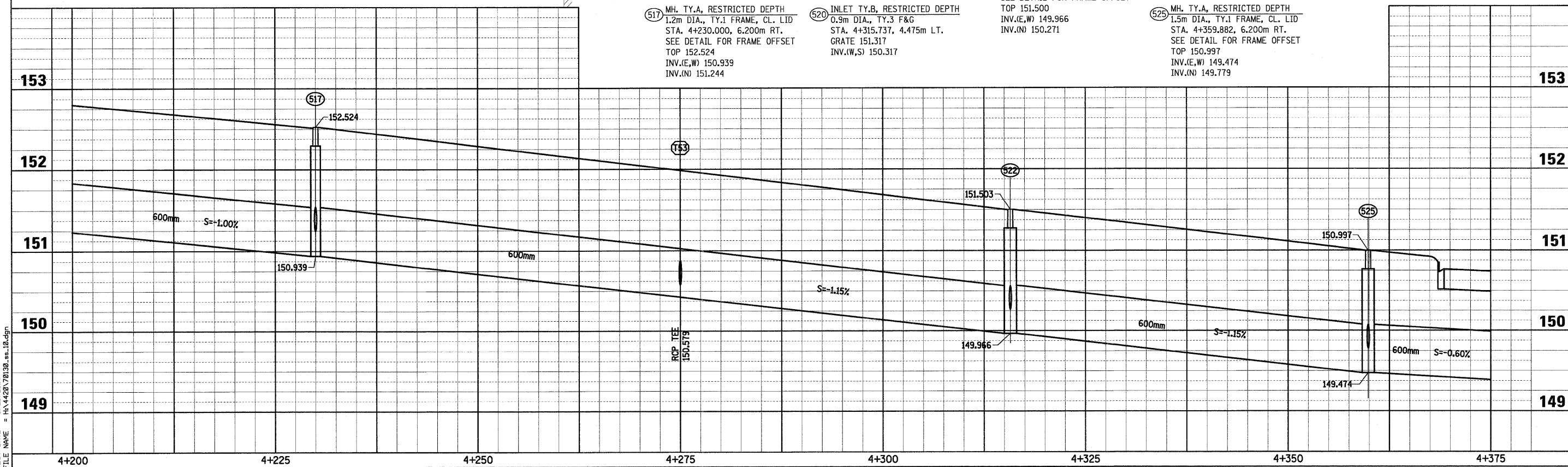
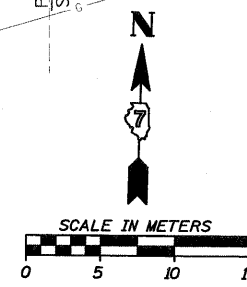

Sheet: 10
 Angle: 1.7120
 Chain: P_IL33

PLOT DATE = 3/20/2009
 FILE NAME = H:\14420\70130_10.dgn

HMG JOB NO. 4420

F.A.P. RTE.	SECTION	COUNTY	TOTAL SHEETS	SHEET NO.
781	1YRS, 2ZRS-1	CRAWFORD	378	131
STA. 4+375		TO STA. 4+550		
FED. ROAD DIST. NO.		ILLINOIS	FED. AID PROJECT	

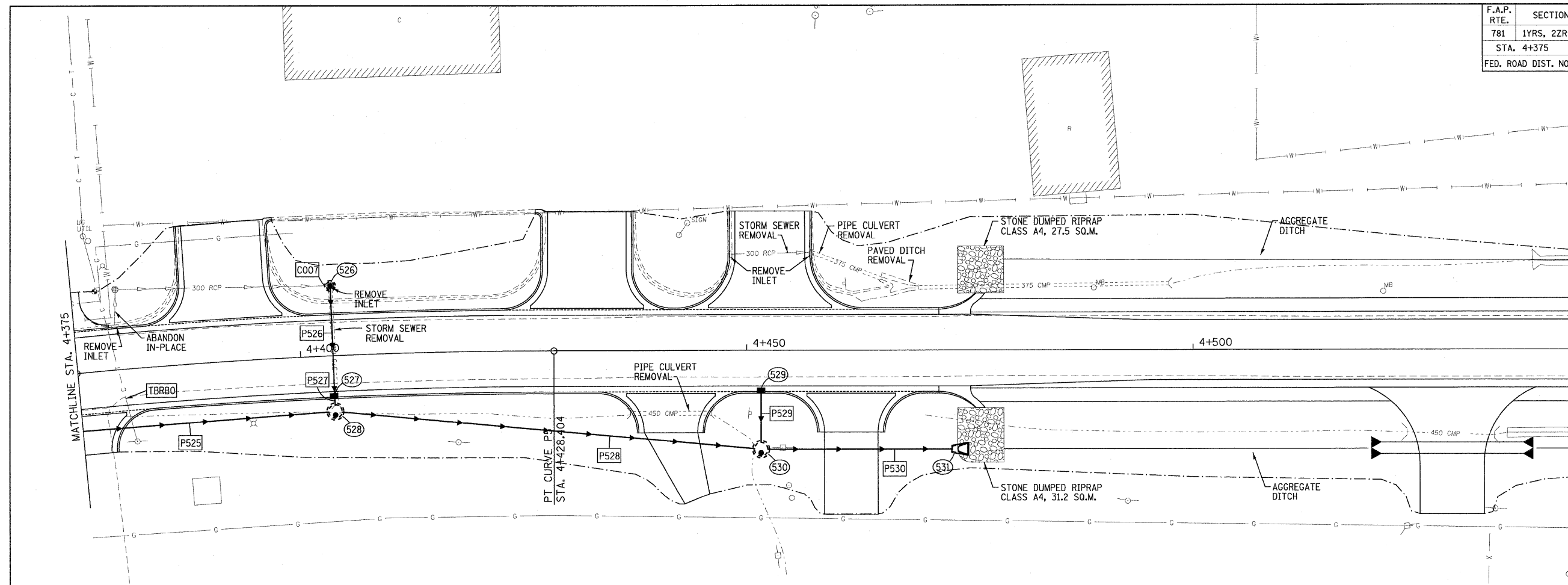

- 526 INLET TY.B, RESTRICTED DEPTH
0.9m DIA., TY.8 GRATE
STA. 4+403.640, 7.860m LT.
GRATE 150.650
INV.(W) 149.619
INV.(S) 149.588
- 527 INLET TY.B, RESTRICTED DEPTH
0.9m DIA., TY.3 F&G
STA. 4+403.640, 4.475m RT.
GRATE 150.430
INV.(N,S) 149.530
- 528 MH. TY.A, RESTRICTED DEPTH
1.5m DIA., TY.1 FRAME, CL. LID
STA. 4+403.640, 6.200m RT.
SEE DETAIL FOR FRAME OFFSET
TOP 150.616
INV.(E,W) 149.219
INV.(N) 149.524
- 529 INLET TY.A, TY.3 F&G
STA. 4+451.600, 4.475m RT.
GRATE 150.172
INV. 149.294
- 530 MH. TY.A, RESTRICTED DEPTH
1.5m DIA., TY.1 FRAME, CL. LID
STA. 4+451.600, 11.000m RT.
SEE DETAIL FOR FRAME OFFSET
TOP 150.189
INV.(E,W) 148.961
INV.(N) 149.266
- 531 P.R.C. FLARED END SECTION, 600
STA. 4+474.750, 11.000m RT.
INV. 148.846
- C007 RECONNECT EXIST. 300mm PIPE
TO INLET NO. 526, INV. ±149.619.
VERIFY EXIST. PIPE INVERT AND
FIELD CUT OPENING IN STRUCTURE.
COST INCIDENTAL TO COST OF
STORM SEWER ITEMS.
- P526 STORM SEWER, CL.A, TY.1, 300
11.516m @ 0.50%
- P527 STORM SEWER, CL.A, TY.1, 300
0.581m @ 1.00%
- P528 STORM SEWER, CL.A, TY.1, 600
46.880m @ 0.55%
- P529 STORM SEWER, CL.A, TY.1, 300
5.563m @ 0.50%
- P530 STORM SEWER, CL.A, TY.1, 600
20.761m @ 0.55%

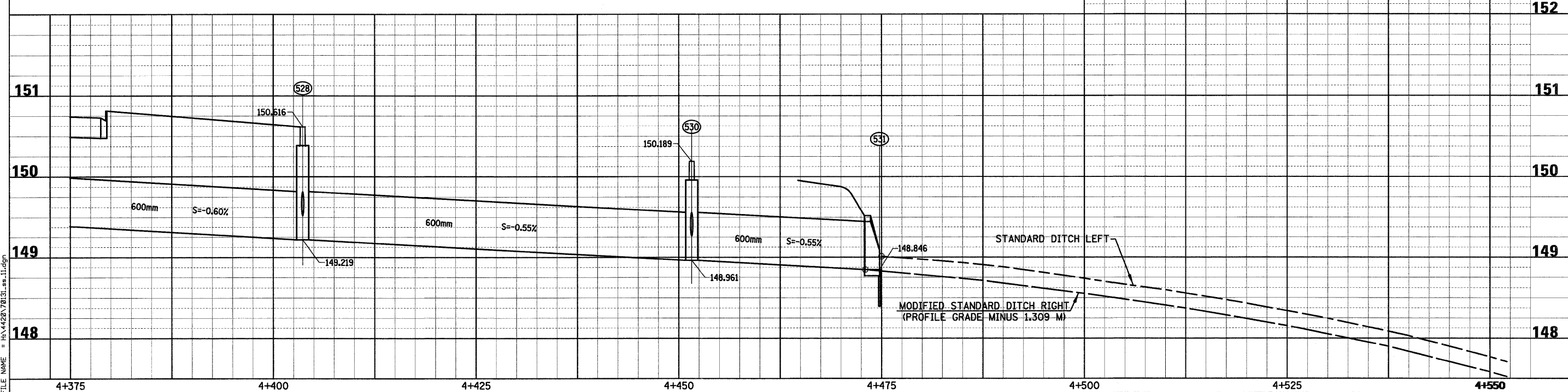
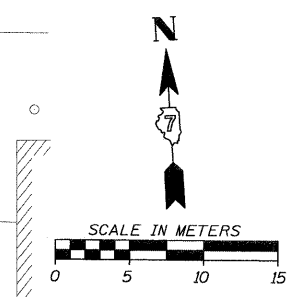

Sheet: 11
Angle: 359.6778
Chain: P_IL33

PLOT DATE = 3/20/2008
FILE NAME = H:\1422\70131.sp.11.dgn

HMG JOB NO. 4450

F.A.P. RTE.	SECTION	COUNTY	TOTAL SHEETS	SHEET NO.
781	1YRS, 2ZRS-1	CRAWFORD	378	132
STA.		TO STA.		
FED. ROAD DIST. NO.		ILLINOIS	FED. AID PROJECT	

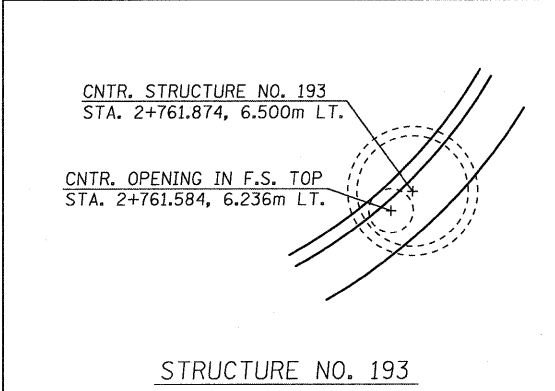

STRUCTURE NO. 193

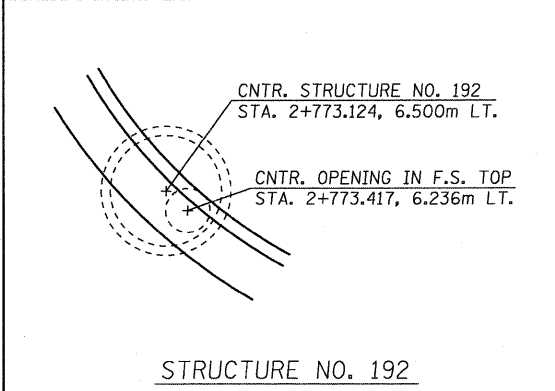

STRUCTURE NO. 192

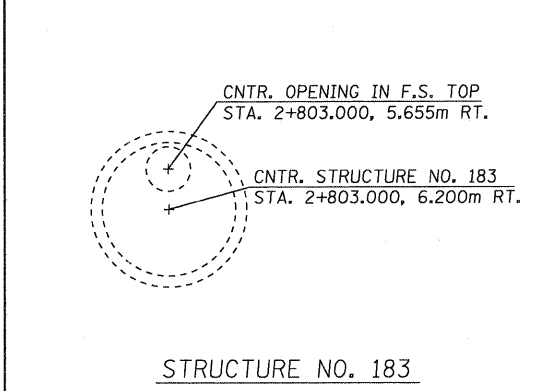

STRUCTURE NO. 183

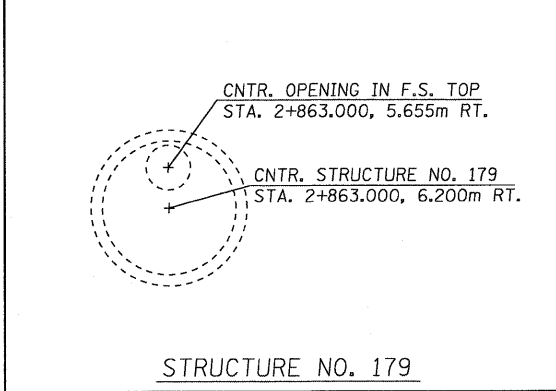

STRUCTURE NO. 179

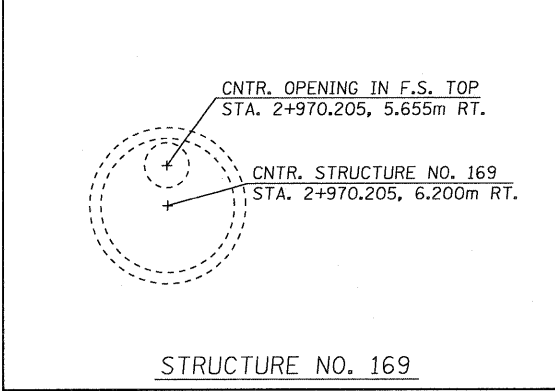

STRUCTURE NO. 169

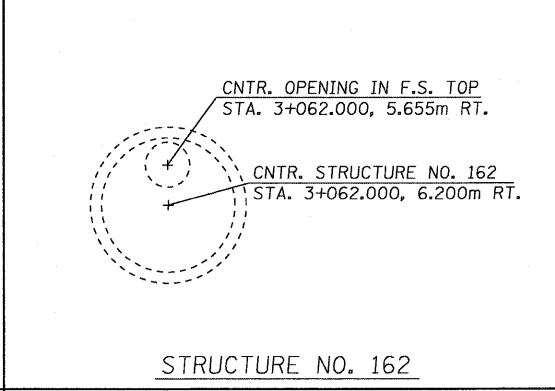

STRUCTURE NO. 162

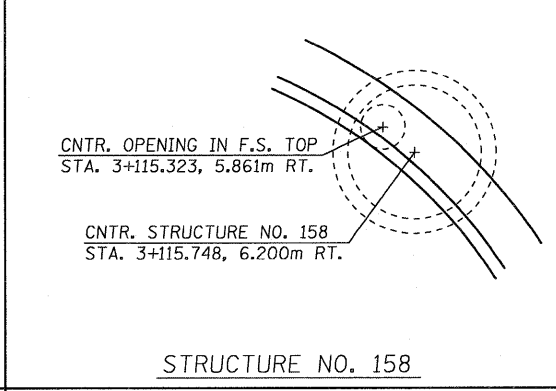

STRUCTURE NO. 158

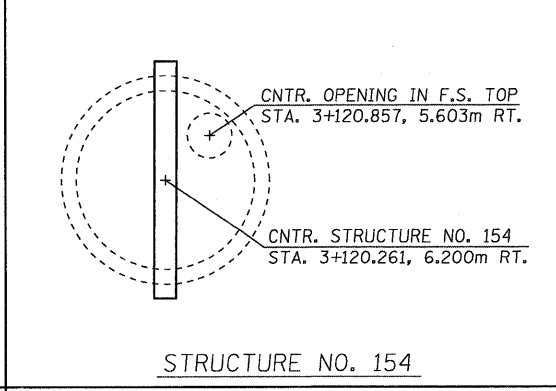

STRUCTURE NO. 154

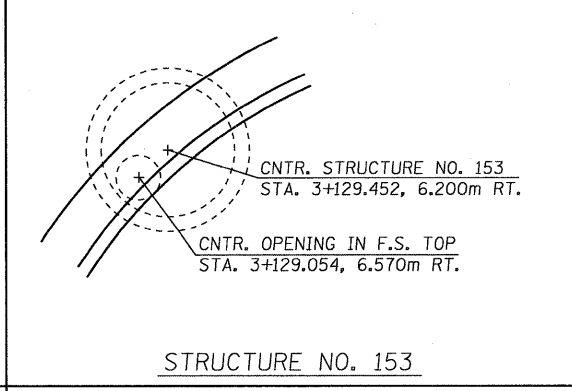

STRUCTURE NO. 153

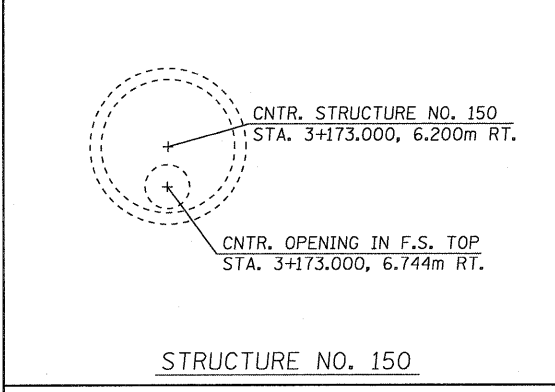

STRUCTURE NO. 150

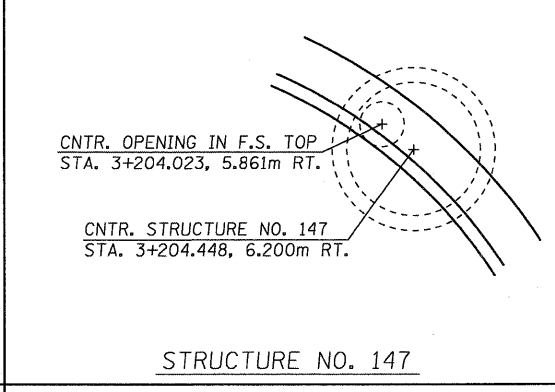

STRUCTURE NO. 147

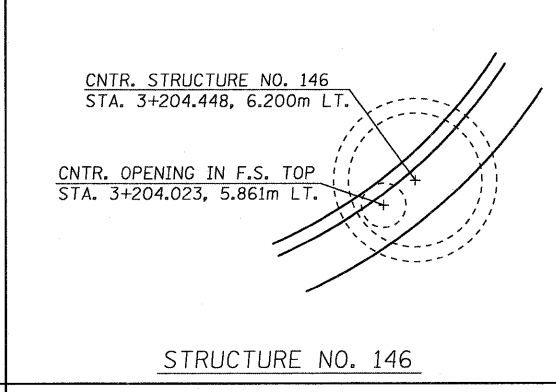

STRUCTURE NO. 146

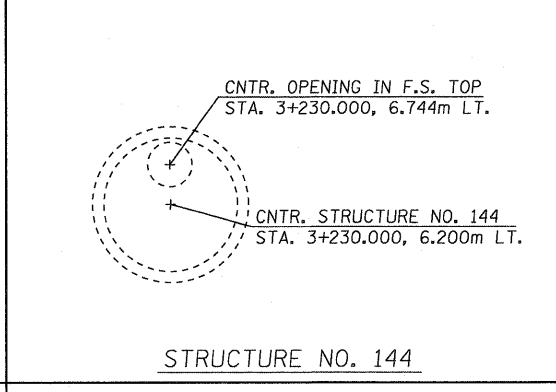

STRUCTURE NO. 144

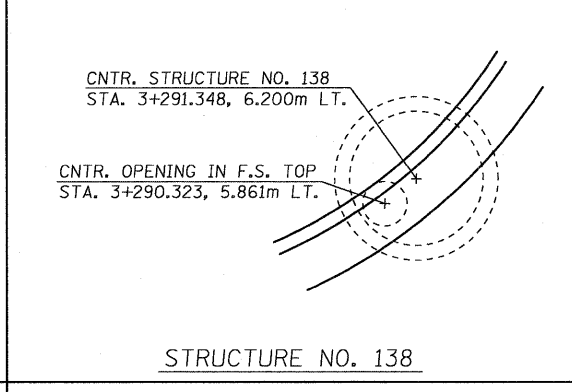

STRUCTURE NO. 138

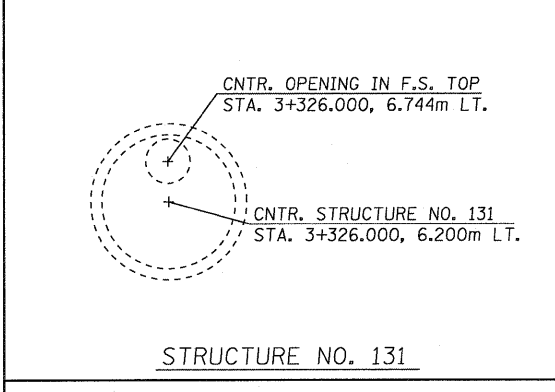

STRUCTURE NO. 131

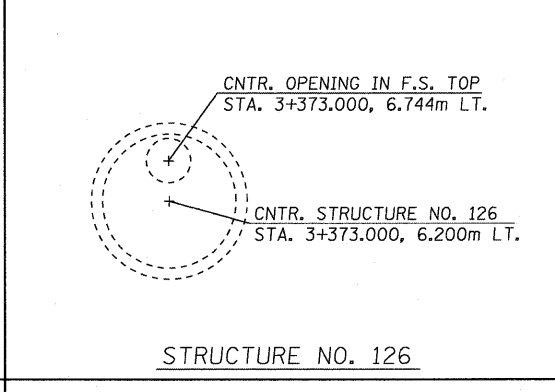

STRUCTURE NO. 126

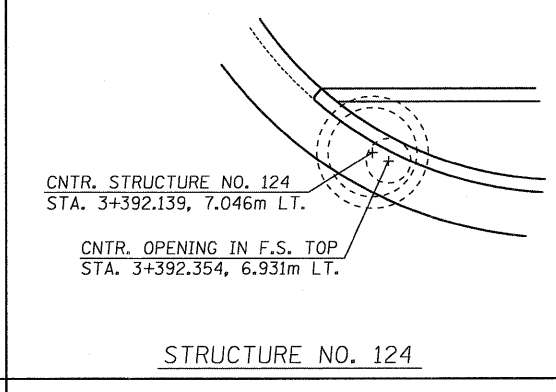

STRUCTURE NO. 124

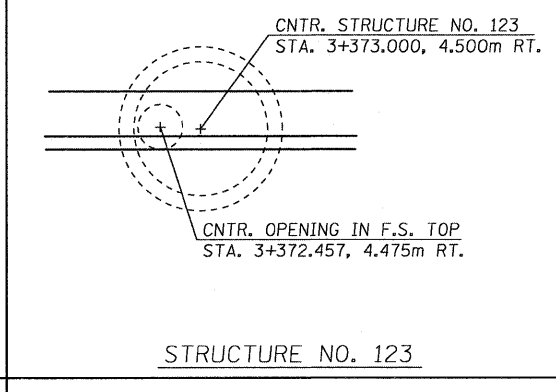

STRUCTURE NO. 123

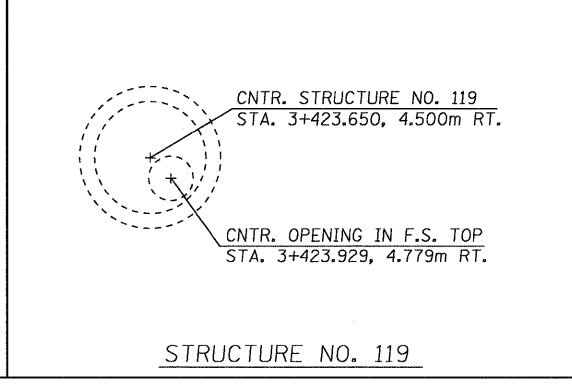

STRUCTURE NO. 119

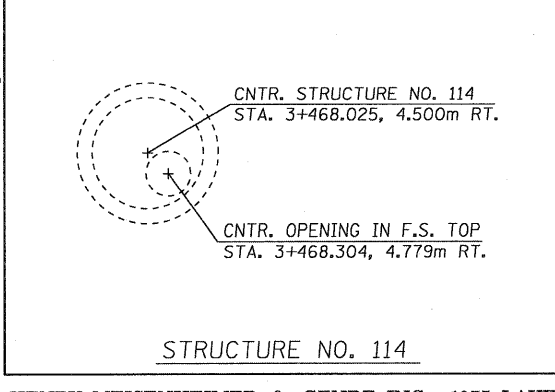

STRUCTURE NO. 114

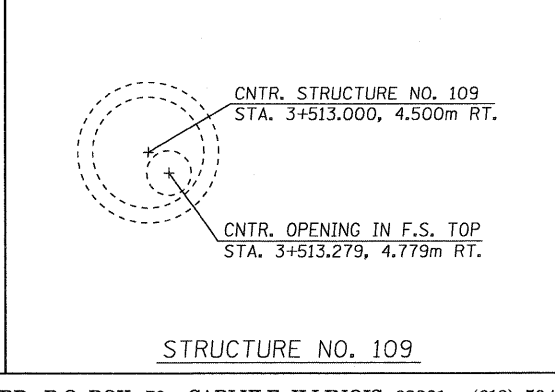

STRUCTURE NO. 109

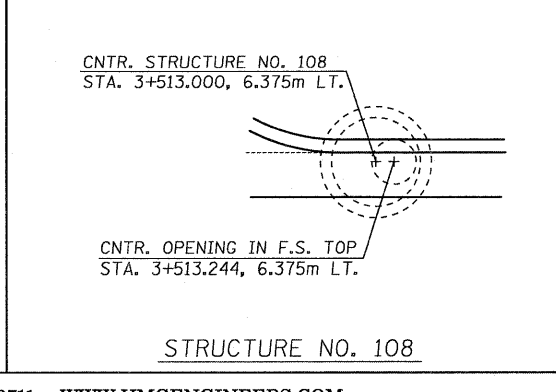

STRUCTURE NO. 108

REVISIONS	
NAME	DATE

ILLINOIS DEPARTMENT OF TRANSPORTATION

STORM SEWER DETAILS

SCALE NO SCALE DRAWN BY EDW
 DATE MARCH 20, 2008 CHECKED BY RGH

PLOT DATE = 3/20/2008
 FILE NAME = H:\1420\170132.dwg

H. M. & G. NO. 4420

F.A.P. RTE.	SECTION	COUNTY	TOTAL SHEETS	SHEET NO.
781	1YRS, 2ZRS-1	CRAWFORD	378	133
STA.		TO STA.		
FED. ROAD DIST. NO.		ILLINOIS	FED. AID PROJECT	

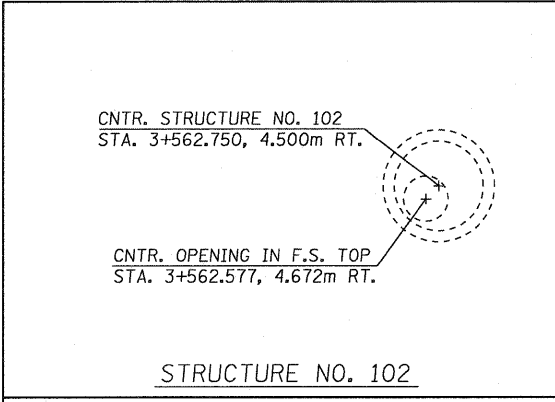

STRUCTURE NO. 102

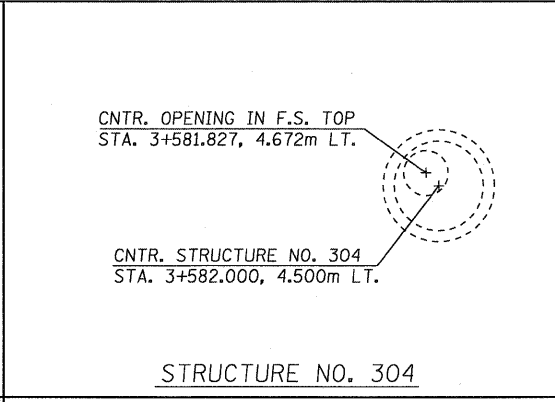

STRUCTURE NO. 304

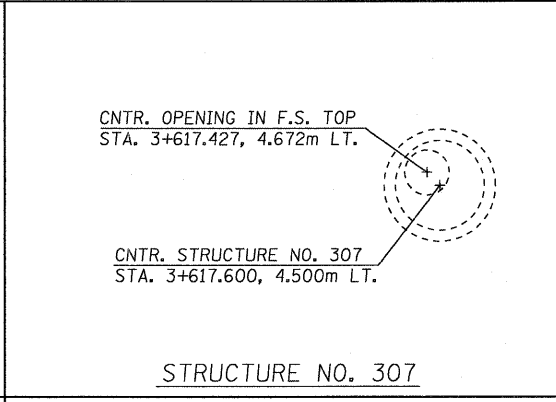

STRUCTURE NO. 307

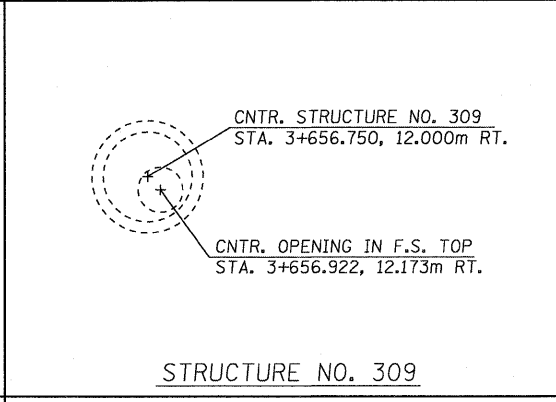

STRUCTURE NO. 309

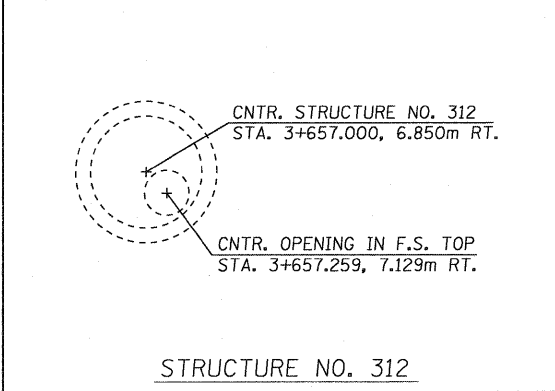

STRUCTURE NO. 312

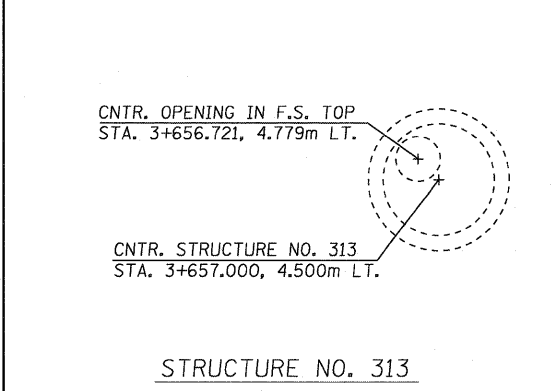

STRUCTURE NO. 313

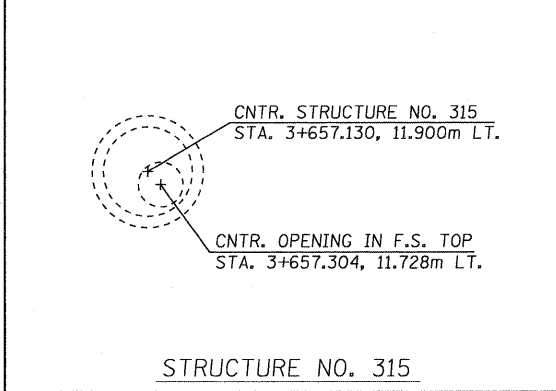

STRUCTURE NO. 315

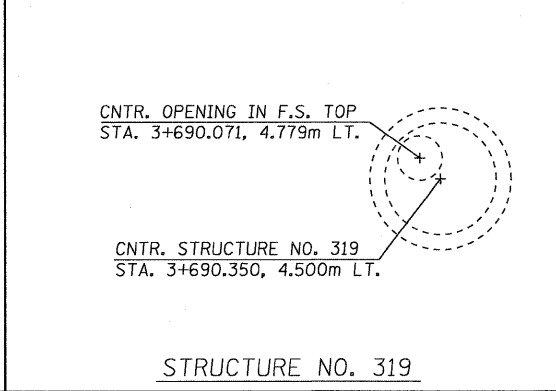

STRUCTURE NO. 319

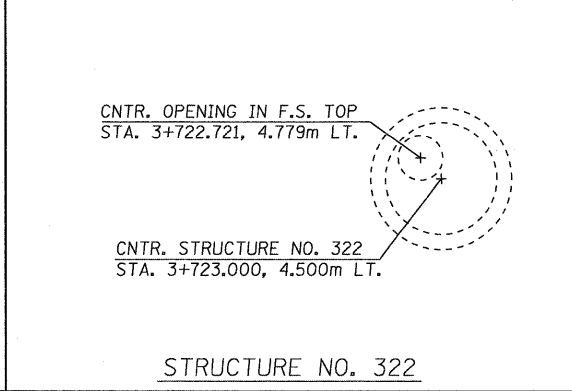

STRUCTURE NO. 322

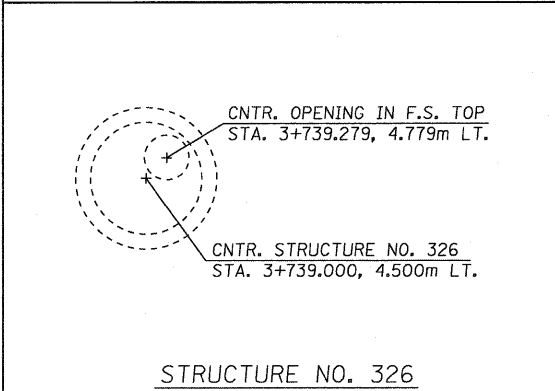

STRUCTURE NO. 326

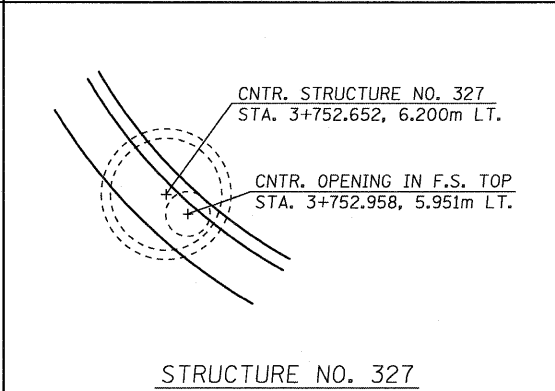

STRUCTURE NO. 327

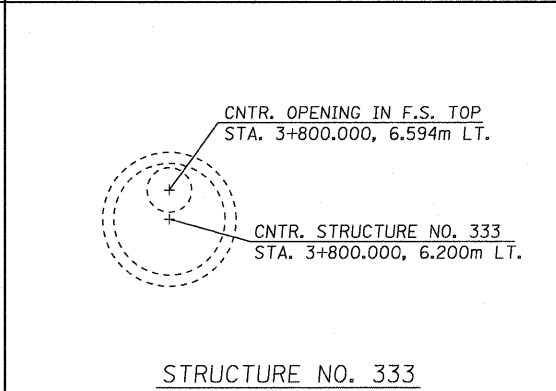

STRUCTURE NO. 333

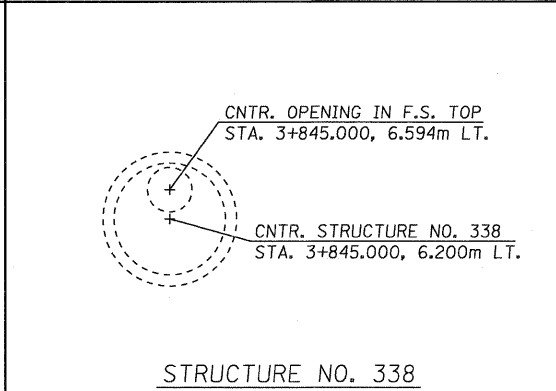

STRUCTURE NO. 338

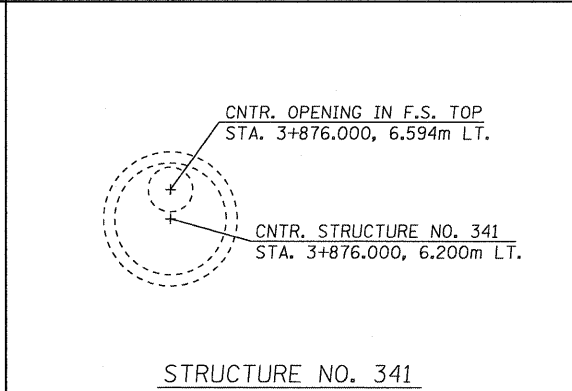

STRUCTURE NO. 341

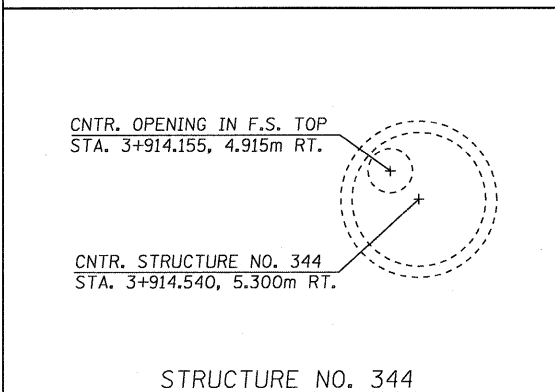

STRUCTURE NO. 344

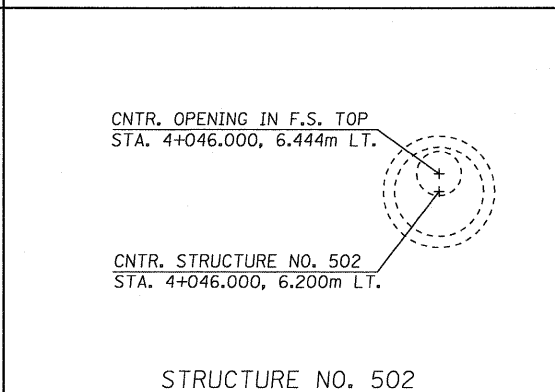

STRUCTURE NO. 502

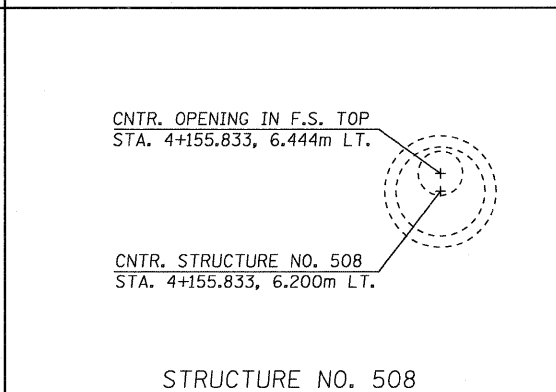

STRUCTURE NO. 508

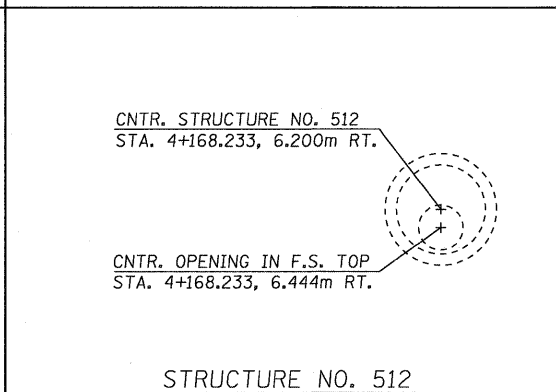

STRUCTURE NO. 512

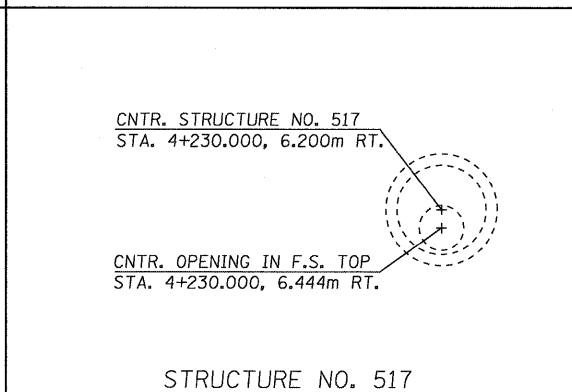

STRUCTURE NO. 517

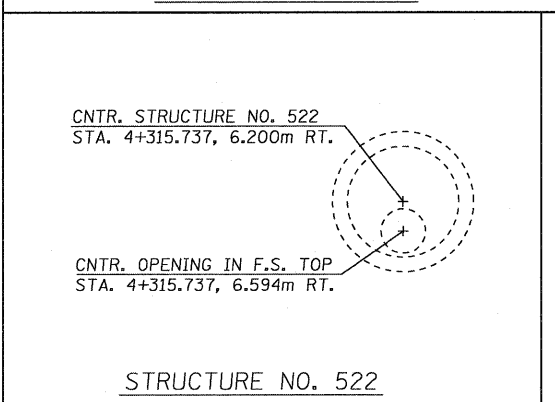

STRUCTURE NO. 522

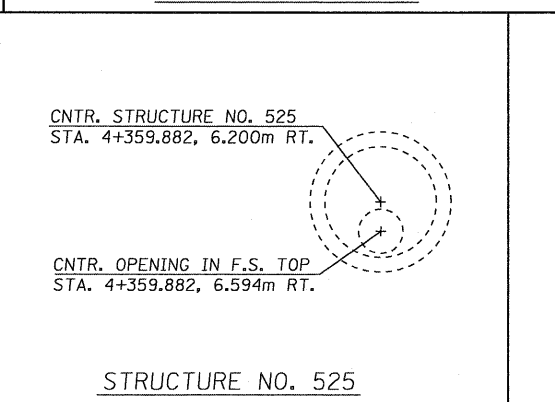

STRUCTURE NO. 525

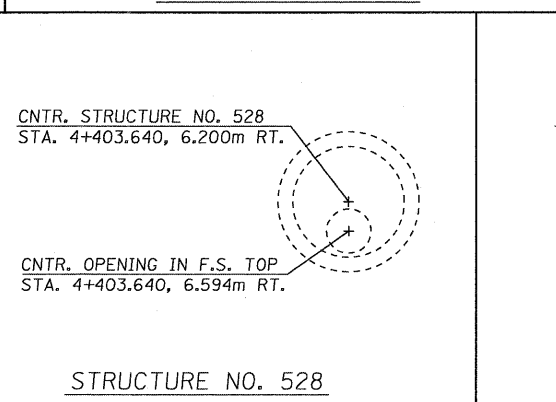

STRUCTURE NO. 528

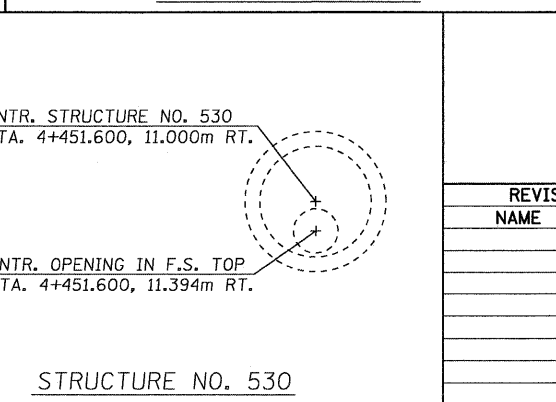

STRUCTURE NO. 530

REVISIONS	
NAME	DATE

ILLINOIS DEPARTMENT OF TRANSPORTATION

STORM SEWER DETAILS

SCALE NO SCALE DRAWN BY EDW
DATE MARCH 20, 2008 CHECKED BY RGH

PLOT DATE = 3/20/2008
FILE NAME = H:\V\20\170133.dwg

H. M. & G. NO. 4420

F.A.P. RTE.	SECTION	COUNTY	TOTAL SHEETS	SHEET NO.
781	1YRS, 2ZRS-1	CRAWFORD	378	135
STA.		TO STA.		
FED. ROAD DIST. NO.		ILLINOIS	FED. AID PROJECT	

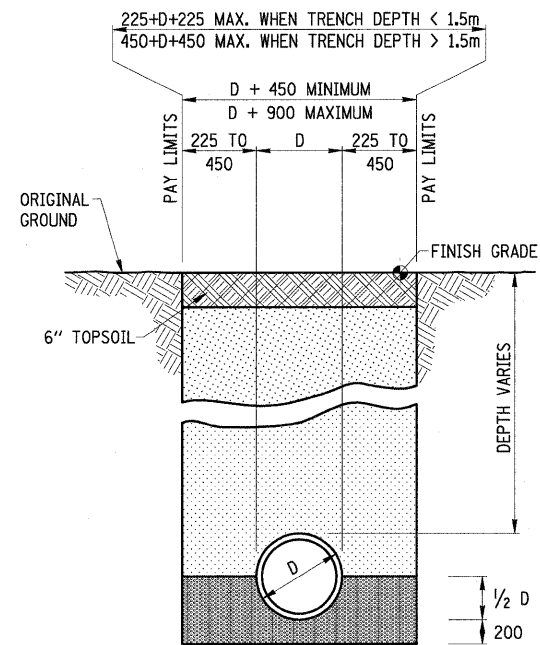

TRENCHING DETAIL UNDER UNPAVED AREAS

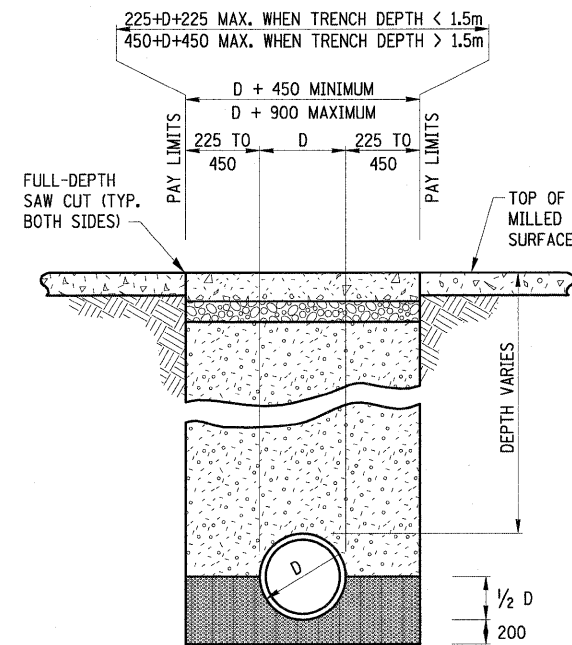

TRENCHING DETAIL UNDER EXIST. PAVEMENT SURFACES

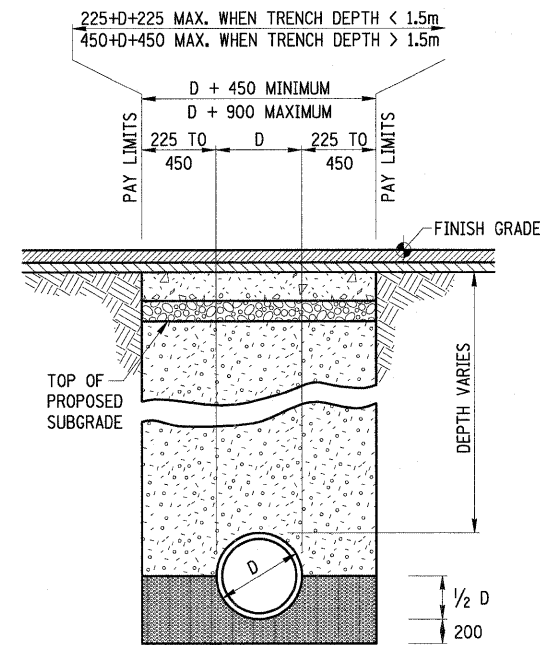

TRENCHING DETAIL UNDER NEW FULL-DEPTH PAVEMENT AREAS

LEGEND

- FINAL BACKFILL**
EXCAVATED MATERIAL IN OTHER LOCATIONS (INCLUDED IN COST OF PIPE)
- FINAL BACKFILL**
TRENCH BACKFILL PER 550.07 AND 208.01 OF THE STANDARD SPECIFICATIONS (PAY ITEM)
- BEDDING/CRADLE**
SELECT GRANULAR BACKFILL PER 550.04 AND 550.07 OF THE STANDARD SPECIFICATIONS (INCLUDED IN COST OF PIPE)

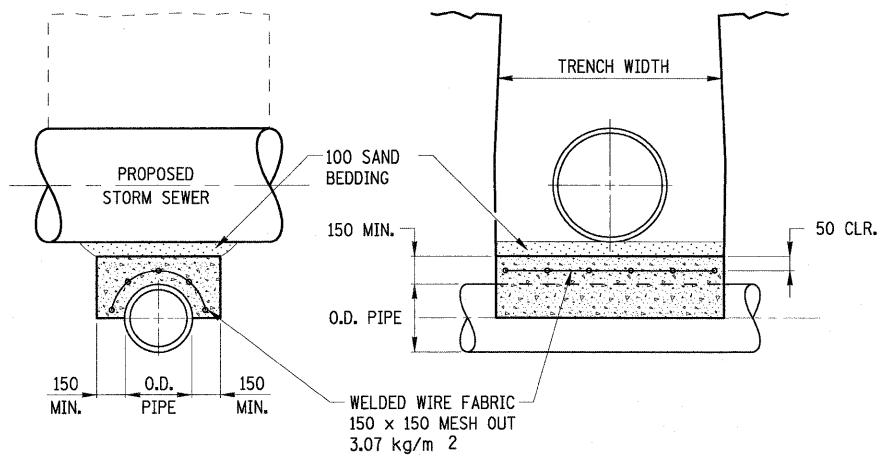

DETAIL - CONCRETE COVER FOR EXISTING UTILITIES

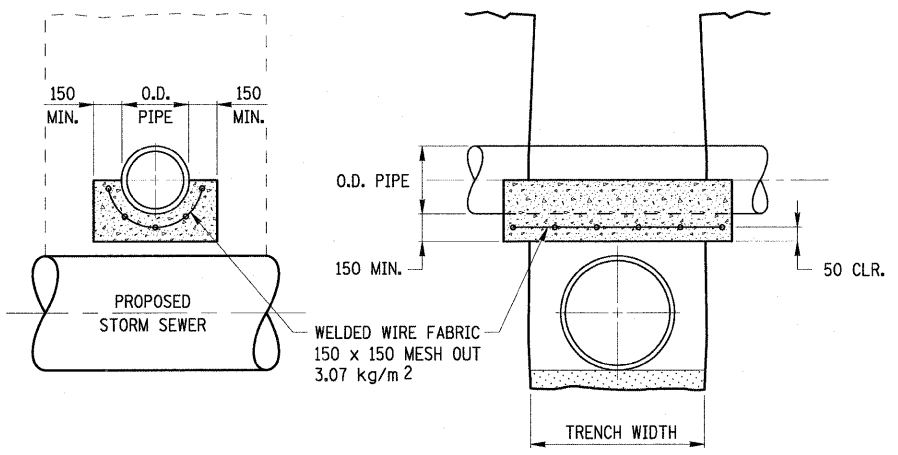

DETAIL - CONCRETE CRADLE FOR EXISTING UTILITIES

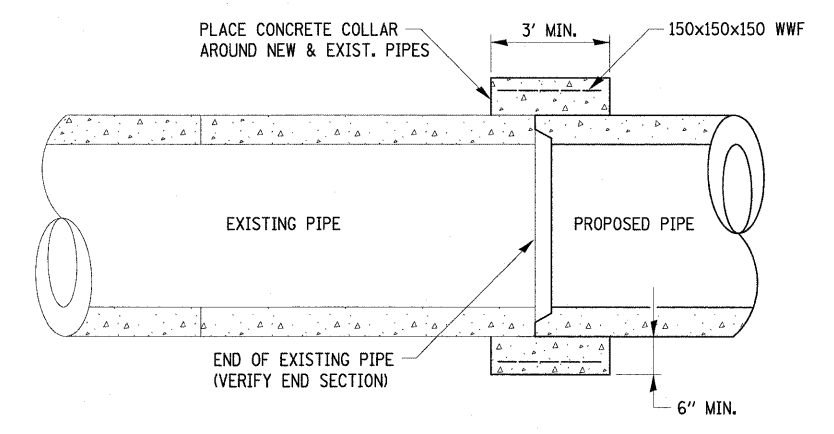

CONCRETE COLLAR DETAIL

NOTES

- CONCRETE CRADLES, COVERS AND COLLARS ARE TO BE PROVIDED AT LOCATIONS DESIGNATED BY THE ENGINEER WHERE THE PROPOSED STORM SEWER CROSSES EXISTING SANITARY SEWER, COMMUNICATION LINES, GAS LINES, AND/OR WATER LINES IN SUFFICIENT PROXIMITY THAT DEFLECTION OF THE EXISTING MAY OCCUR.
- THE COST OF THE CONCRETE CRADLES, COVERS AND COLLARS SHALL BE PAID FOR AT THE CONTRACT UNIT PRICE PER CUBIC METER FOR CLASS SI CONCRETE (SPECIAL).
- THE WELDED WIRE FABRIC AND SAND BEDDING MATERIAL WILL NOT BE PAID FOR SEPARATELY. THE COST FOR THESE ITEMS SHALL BE INCLUDED IN THE COST OF CLASS SI CONCRETE (SPECIAL).
- WOOD OR METAL FORMS WILL NOT BE REQUIRED.

ALL DIMENSIONS ARE IN MILLIMETERS UNLESS OTHERWISE SHOWN.

REVISIONS	
NAME	DATE

ILLINOIS DEPARTMENT OF TRANSPORTATION
STORM SEWER DETAILS
SCALE NO SCALE
DATE APRIL 18, 2008
DRAWN BY EDW
CHECKED BY RGH

PLOT DATE = 4/18/2008
FILE NAME = HV1428170135.dwg

H. M. & G. INC. 4420

F.A.P. RTE.	SECTION	COUNTY	TOTAL SHEETS	SHEET NO.
781	1YRS, 2ZRS-1	CRAWFORD	378	136
STA.		TO STA.		
FED. ROAD DIST. NO.		ILLINOIS	FED. AID PROJECT	

IF DEPTH PERMITS, CONTRACTOR HAS THE OPTION TO USE A CORBELED MANHOLE, TYPE A AS A "RESTRICTED DEPTH MANHOLE" AS SHOWN HERE

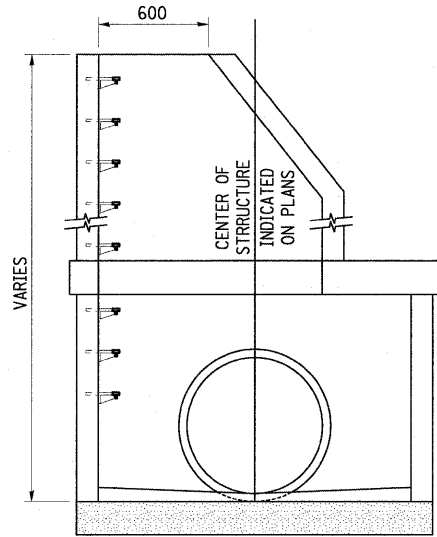

RESTRICTED DEPTH MANHOLE

"TOP" ELEVATION AS INDICATED ON THE STORM SEWER PLAN

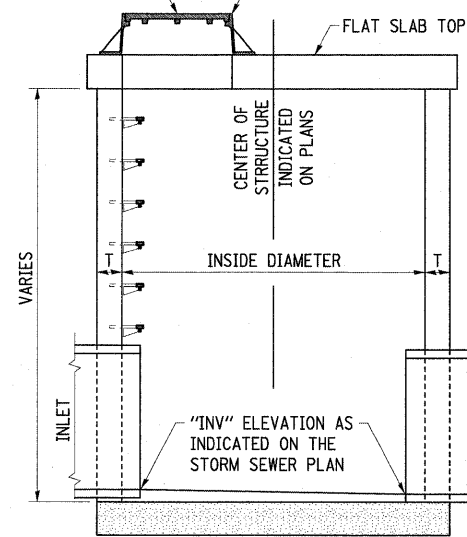

TYPE B INLET

"GRATE" ELEVATION AS INDICATED ON THE STORM SEWER PLAN

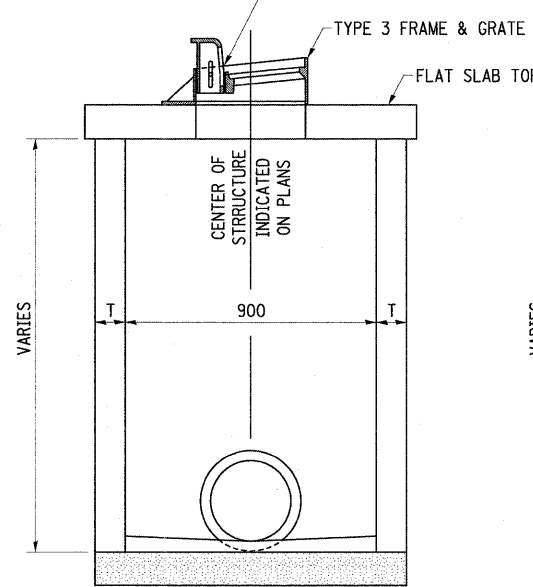

TYPE A INLET

"TOP" ELEVATION AS INDICATED ON THE STORM SEWER PLAN

STORM SEWER CONSTRUCTION NOTES

- BEFORE ORDERING PIPE CULVERTS, PIPE DRAINS, MANHOLES, INLETS, STORM SEWERS OR OTHER DRAINAGE STRUCTURES, THE CONTRACTOR SHALL CONSULT WITH THE ENGINEER FOR EXACT LENGTHS, DIMENSIONS, INVERTS AND ALIGNMENTS AND SUBMIT REQUIRED SHOP DRAWINGS.
- CARE SHOULD BE EXERCISED IN CONSTRUCTION OF MANHOLE STRUCTURES TO BE LOCATED UNDER PERMANENT SURFACES DUE TO MINOR ELEVATION ADJUSTMENTS IN THE FIELD. THE CONTRACTOR IS ADVISED TO CAST STRUCTURES TO ACCOMMODATE SUCH MINOR ADJUSTMENTS. USE OF ADJUSTING RINGS IS RECOMMENDED.
- NOTE THAT ALL OF THE TYPE B INLETS REQUIRE FLAT SLAB TOPS WITH THE CENTER OF THE 2' OPENING ALIGNED WITH THE CENTER OF THE STRUCTURE.
- "RESTRICTED DEPTH MANHOLES", OF THE DIAMETER SPECIFIED, REFER TO 4', 5', 6' OR 8' DIAMETER MANHOLES REQUIRING FLAT SLAB TOPS AND A 2' I.D. RISER OF VARYING DEPTH IF THE OVERALL DEPTH WILL ALLOW FOR A RISER.
- THE STATION AND OFFSET SHOWN ON THE STORM SEWER PLAN IS FOR THE LOCATION OF THE CENTER OF THE STRUCTURE. THIS IS NOT NECESSARILY THE CENTER OF THE 600mm OPENING. REFER TO THE STRUCTURE OFFSET DETAIL SHEETS FOR THE EXACT LAYOUT.

STRUCTURE POINT-OF-GRADE DETAILS

POINT LOADS SHALL NOT BE ALLOWED BETWEEN SEWER OR SEWER CASING AND WATER MAIN
 PROVIDE ADEQUATE SUPPORT FOR EXISTING WATER MAIN TO PREVENT DAMAGE DUE TO SETTLEMENT OF SEWER TRENCH

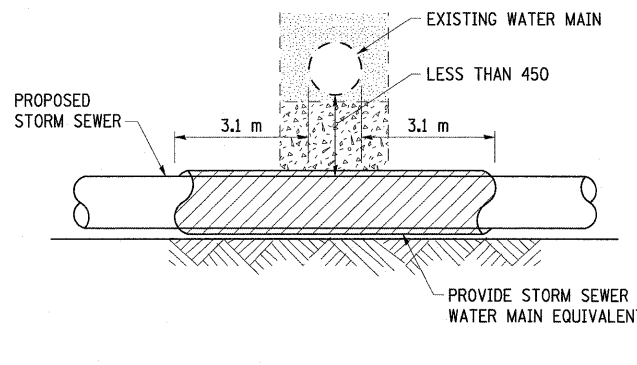

PROVIDE ADEQUATE SUPPORT FOR EXISTING WATER MAIN TO PREVENT DAMAGE DUE TO SETTLEMENT OF SEWER TRENCH

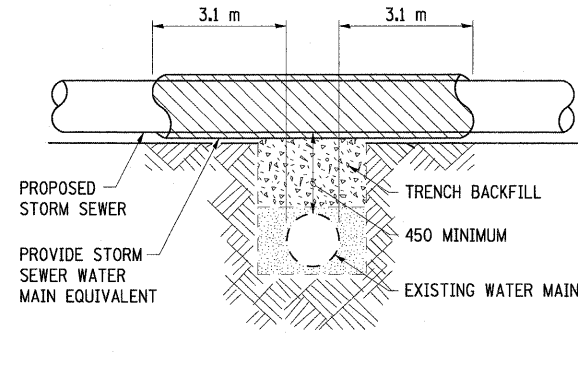

PLACEMENT OF OR EXISTING WATER MAIN BELOW EXISTING OR PROPOSED SEWER LINE WITH LESS THAN 18" MINIMUM VERTICAL SEPARATION NOT ALLOWED.

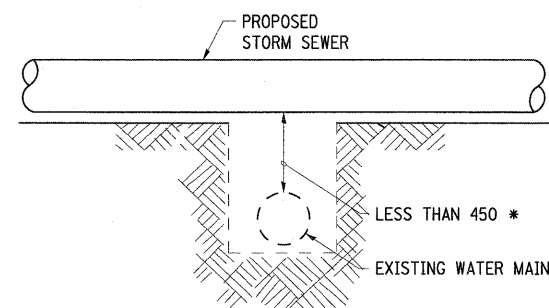

* NOT ALLOWED. MUST MAINTAIN 18" VERTICAL SEPARATION

PROPOSED SEWER LINE BELOW EXISTING WATER MAIN

PROPOSED SEWER LINE ABOVE EXISTING WATER MAIN

WHEN PROPOSED SEWER (OR WATER) IS LOCATED 3.1 m OR MORE FROM EXISTING WATER (OR SEWER) NO SPECIAL CONSTRUCTION IS REQUIRED

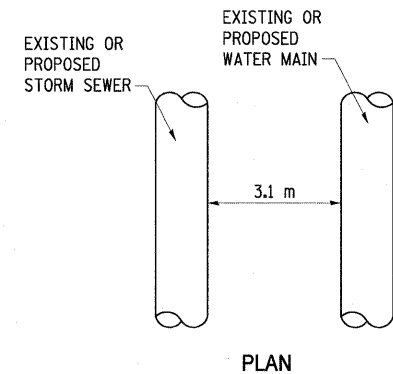

PLAN

WHEN PROPOSED SEWER (OR WATER) IS LOCATED LESS THAN 3.1 m FROM EXISTING WATER (OR SEWER), THE DETAILS TO THE LEFT SHALL APPLY

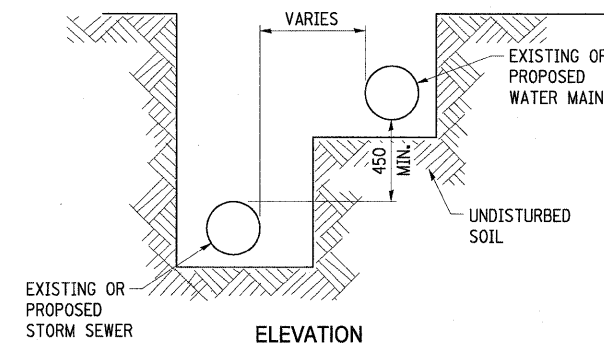

ELEVATION

WATER AND SEWER HORIZONTAL SEPARATION REQUIREMENTS

ALL DIMENSIONS ARE IN MILLIMETERS UNLESS OTHERWISE SHOWN.

REVISIONS	
NAME	DATE

ILLINOIS DEPARTMENT OF TRANSPORTATION

STORM SEWER DETAILS

SCALE NO SCALE
 DATE APRIL 18, 2008
 DRAWN BY EDW
 CHECKED BY RGH

F.A.P. RTE.	SECTION	COUNTY	TOTAL SHEETS	SHEET NO.
781	1YRS, 2ZRS-1	CRAWFORD	378	137
STA.		TO STA.		
FED. ROAD DIST. NO.		ILLINOIS	FED. AID PROJECT	

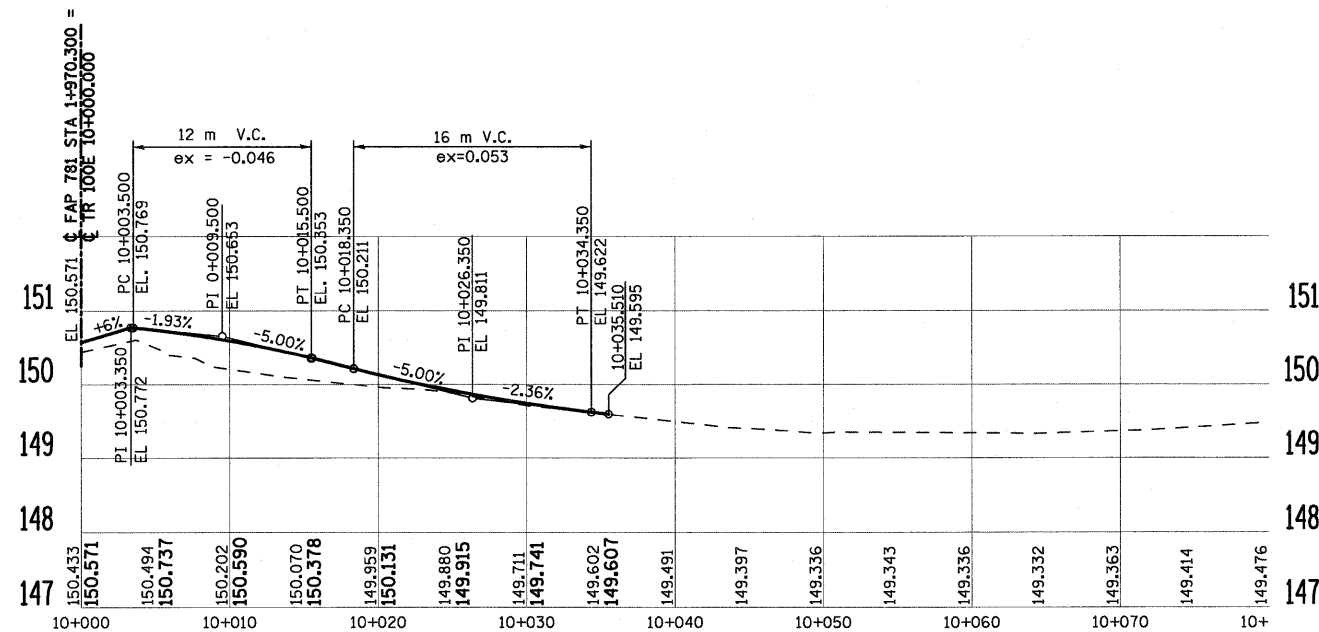

TR 100E (RT)

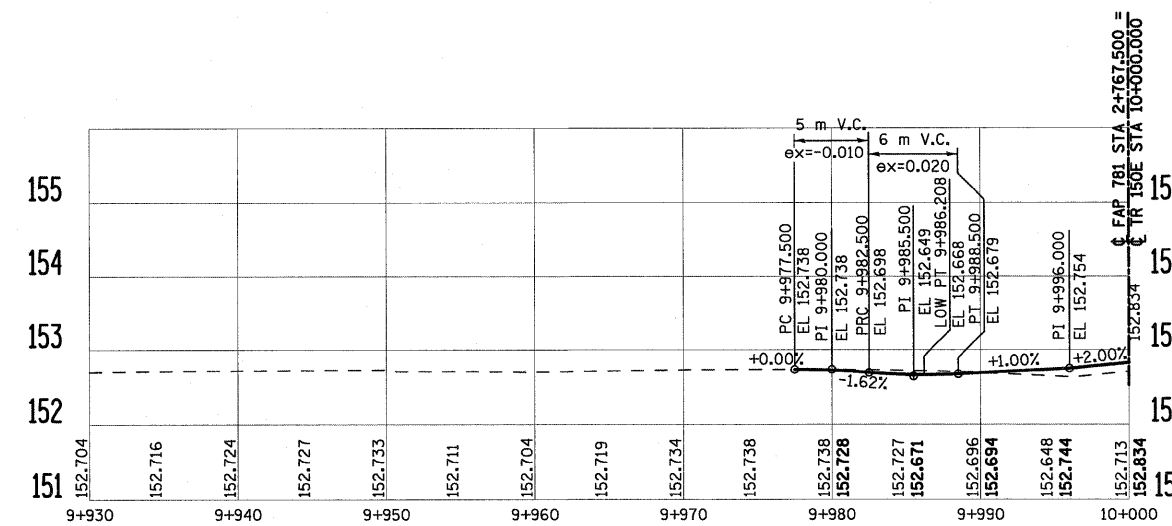

TR 150E (LT)

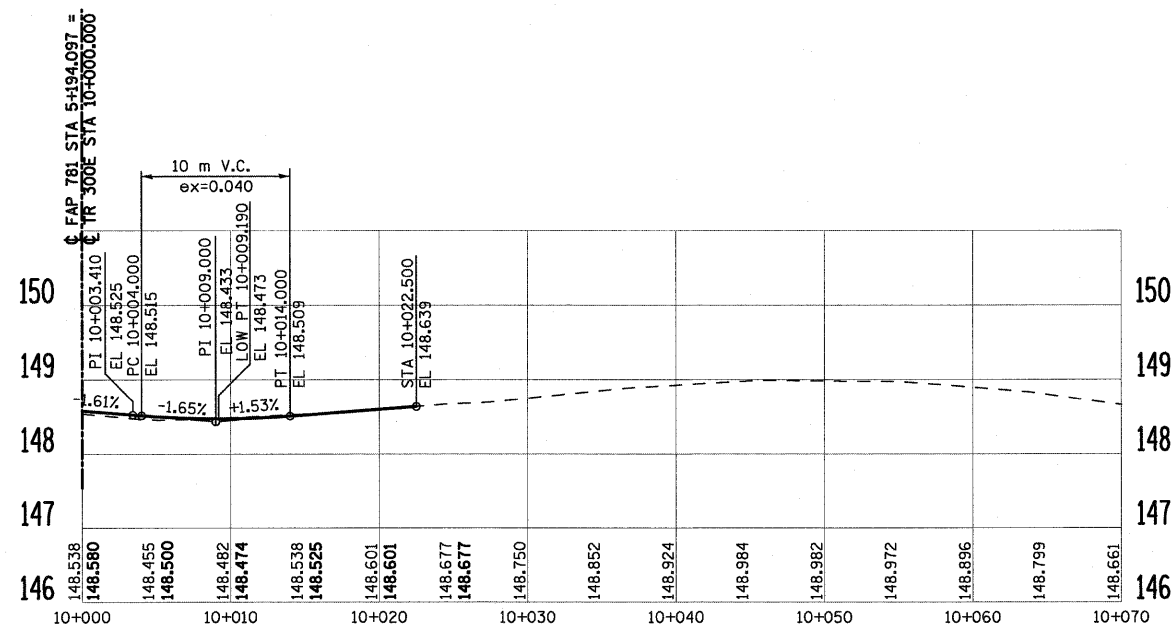

TR 300E (RT)

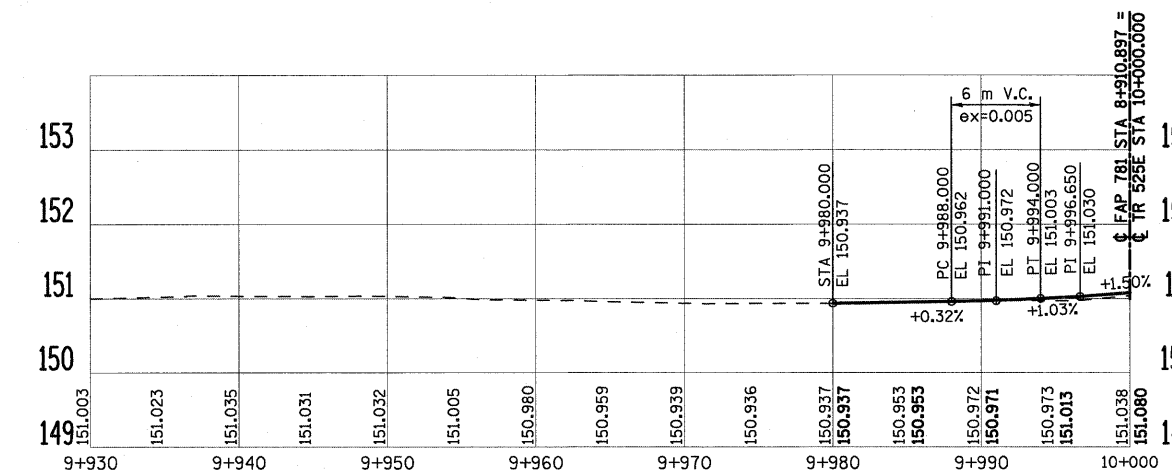

TR 525E (LT)

PLOT DATE = 4/18/2008
FILE NAME = HA\428\78137_mpf80.dgn

REVISIONS	
NAME	DATE

ILLINOIS DEPARTMENT OF TRANSPORTATION
PROPOSED SIDE ROAD PROFILES
SCALE AS SHOWN
DATE APRIL 18, 2008
DRAWN BY EDW
CHECKED BY RGH

F.A.P. RTE.	SECTION	COUNTY	TOTAL SHEETS	SHEET NO.
781	1YRS, 2ZRS-1	CRAWFORD	378	139
STA.		TO STA.		
FED. ROAD DIST. NO.		ILLINOIS	FED. AID PROJECT	

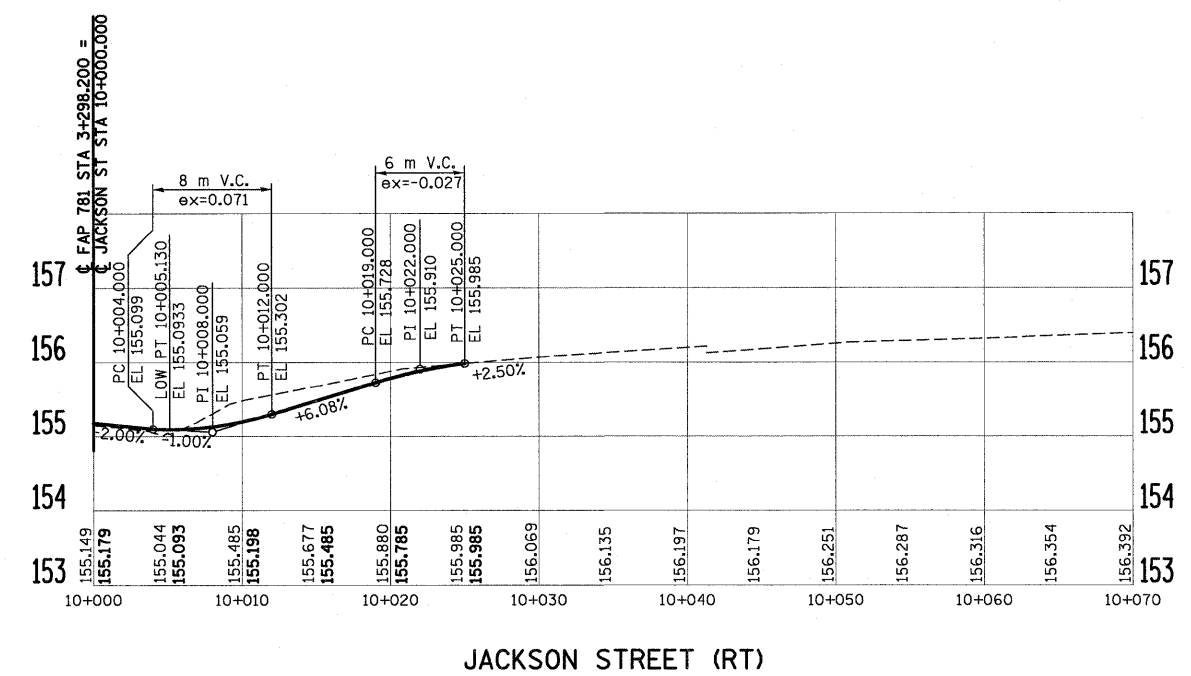
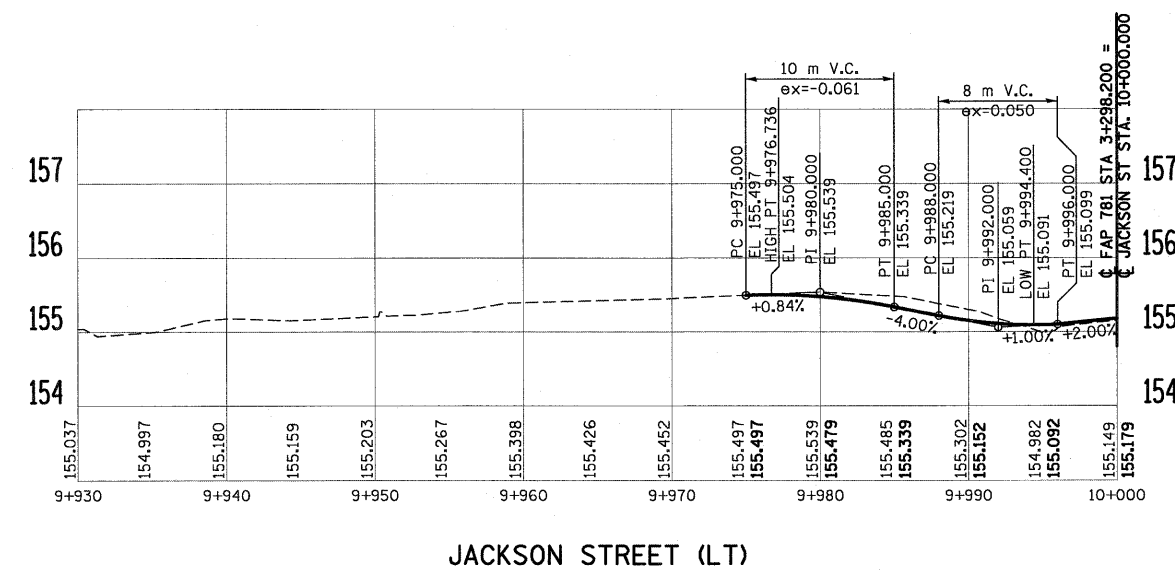
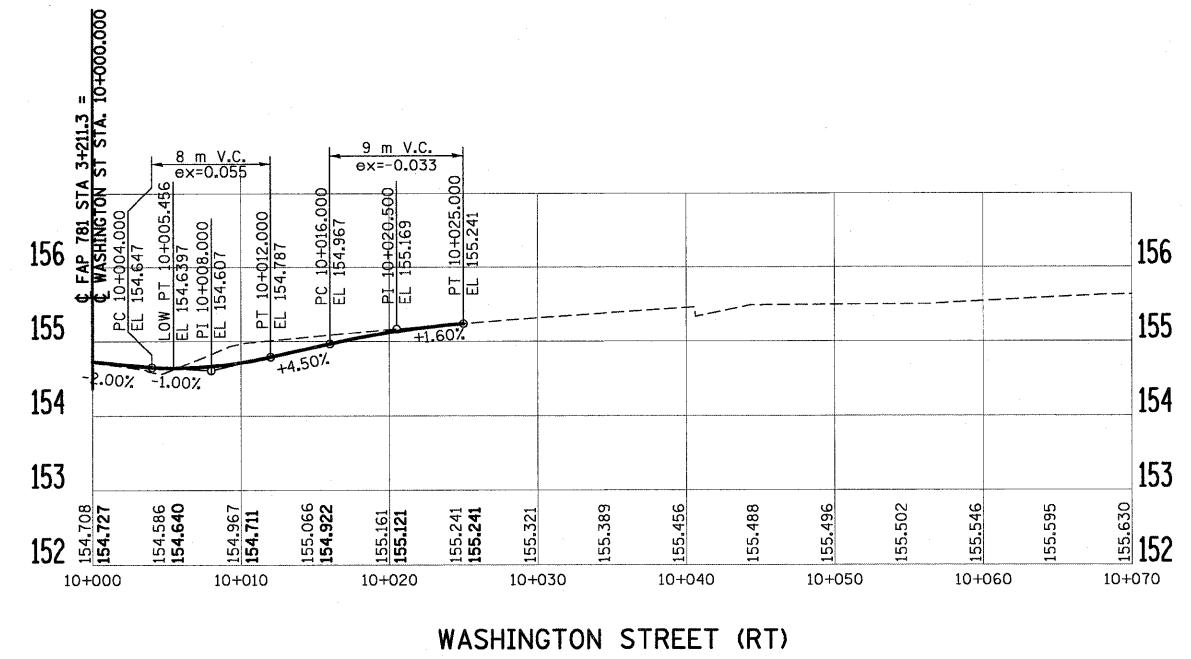
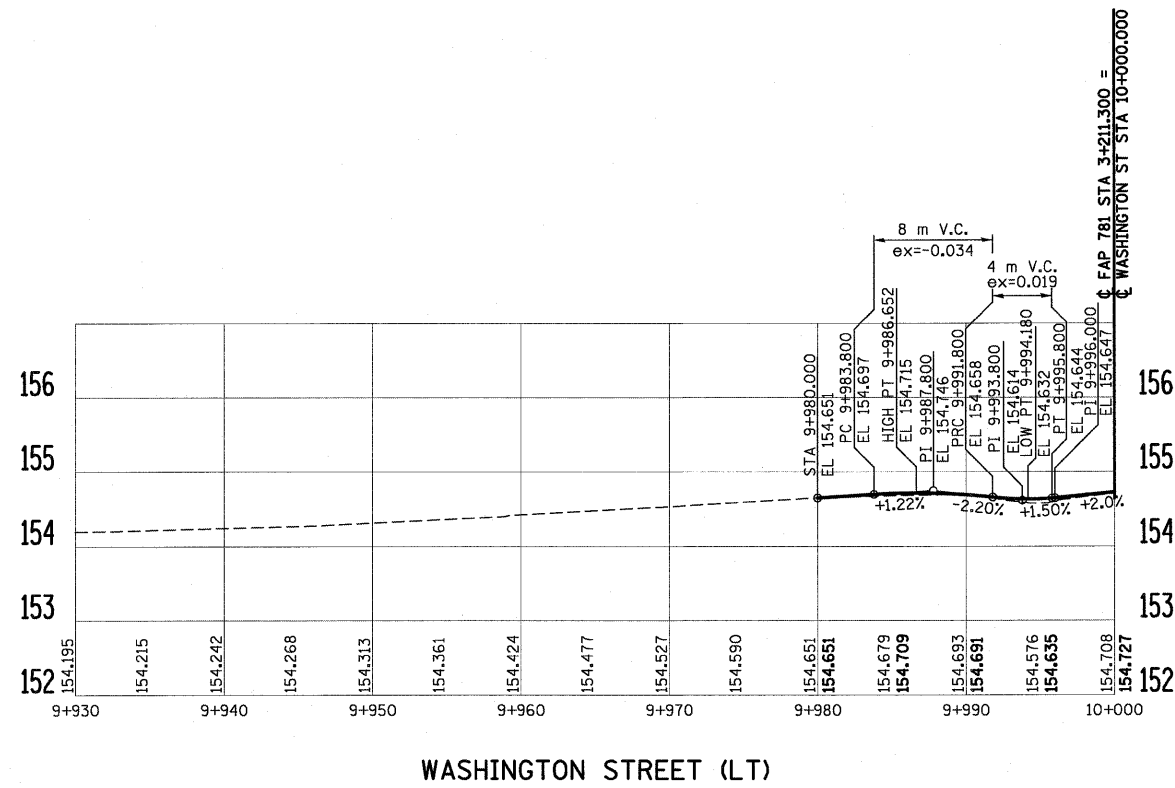

PLOT DATE = 3/20/2008
FILE NAME = H:\4420\70139\ppr705.dgn

REVISIONS	
NAME	DATE

ILLINOIS DEPARTMENT OF TRANSPORTATION

PROPOSED SIDE ROAD PROFILES

SCALE AS SHOWN DRAWN BY EDW
DATE MARCH 20, 2008 CHECKED BY RGH

F.A.P. RTE.	SECTION	COUNTY	TOTAL SHEETS	SHEET NO.
781	1YRS, 2ZRS-1	CRAWFORD	378	140
STA.		TO STA.		
FED. ROAD DIST. NO.		ILLINOIS	FED. AID PROJECT	

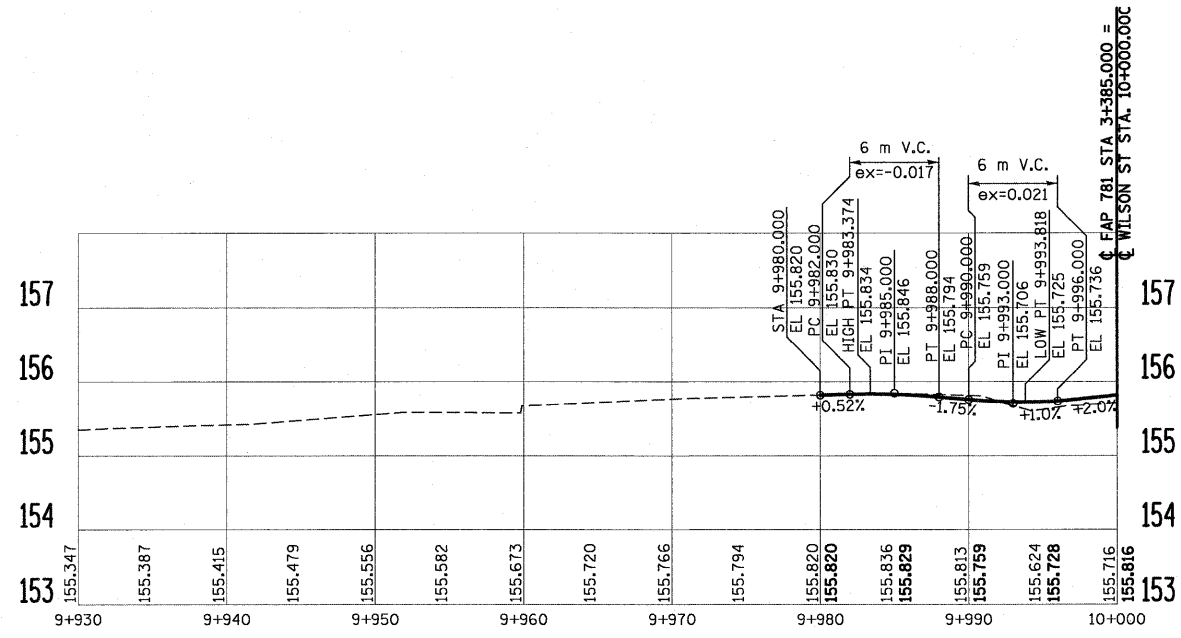

WILSON STREET (LT)

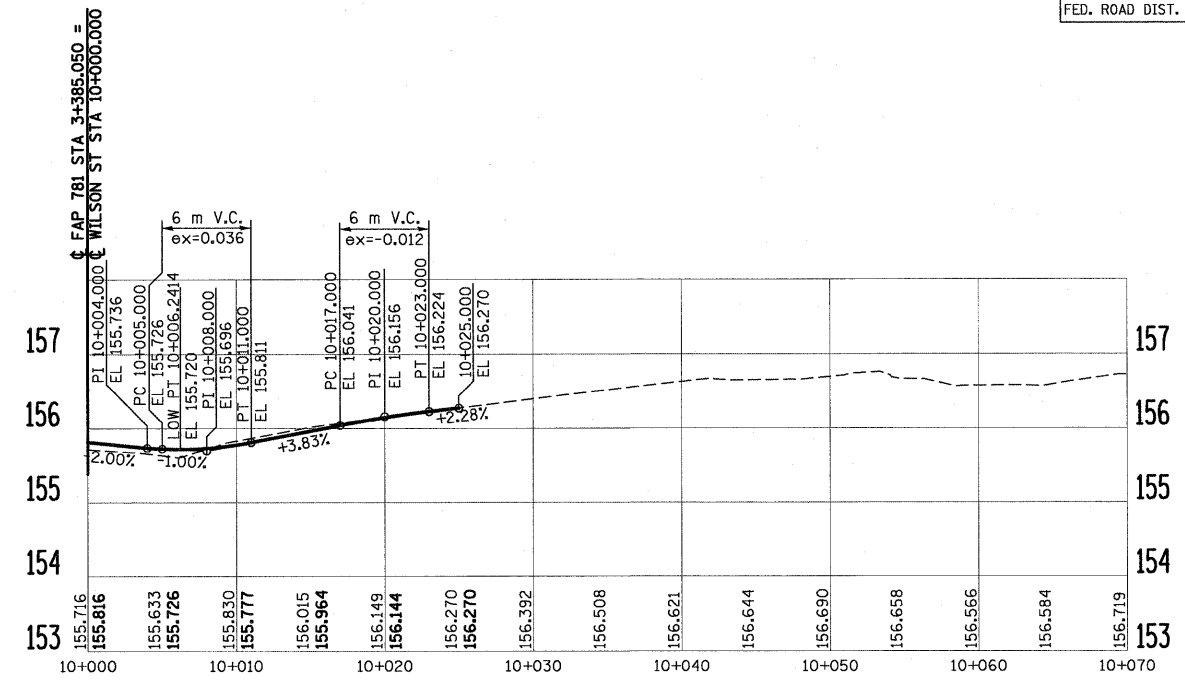

WILSON STREET (RT)

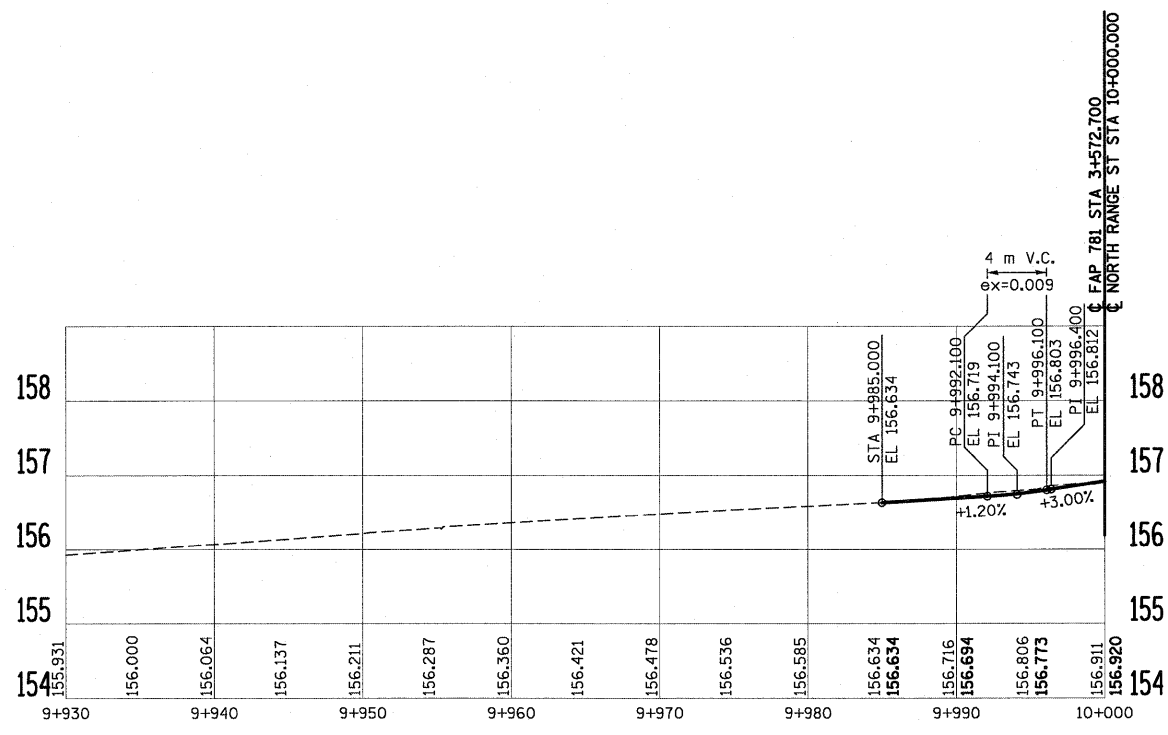

NORTH RANGE STREET

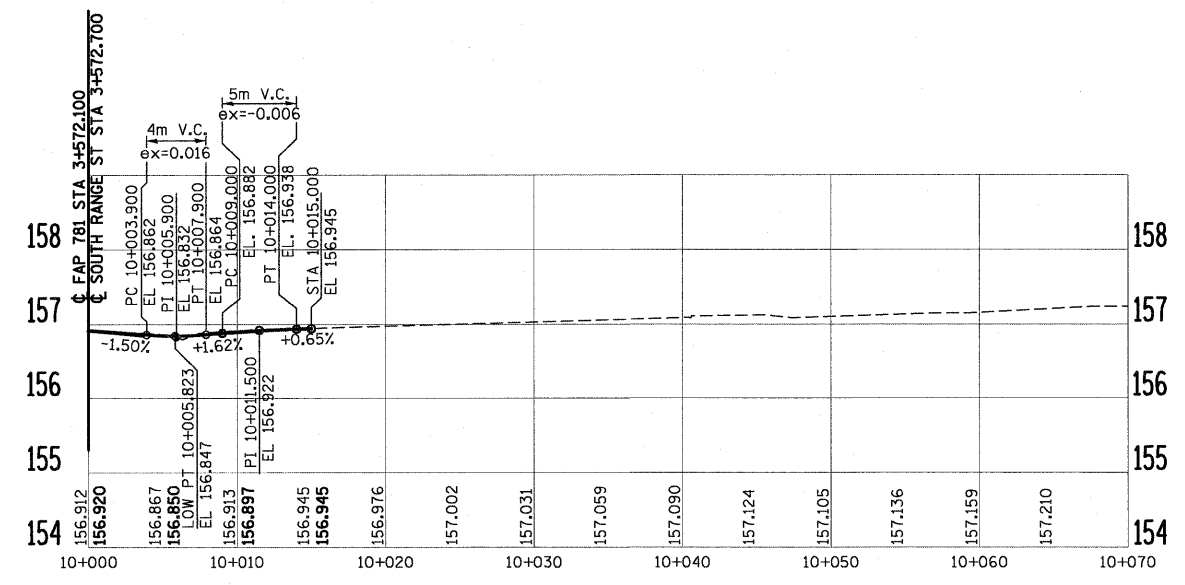

SOUTH RANGE STREET

PLOT DATE = 3/26/2008
FILE NAME = H:\1420\70140_arp\781.dgn

REVISIONS	
NAME	DATE

ILLINOIS DEPARTMENT OF TRANSPORTATION
PROPOSED SIDE ROAD PROFILES
SCALE AS SHOWN DRAWN BY EDW
DATE MARCH 20, 2008 CHECKED BY RGH

F.A.P. RTE.	SECTION	COUNTY	TOTAL SHEETS	SHEET NO.
781	1YRS, 2ZRS-1	CRAWFORD	378	141
STA.		TO STA.		
FED. ROAD DIST. NO.		ILLINOIS	FED. AID PROJECT	

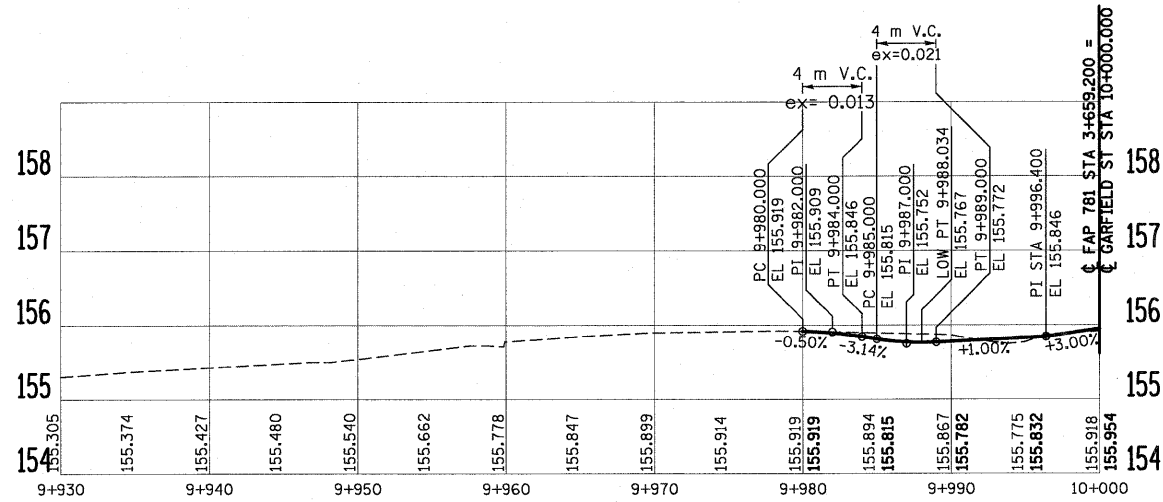

GARFIELD STREET (LT)

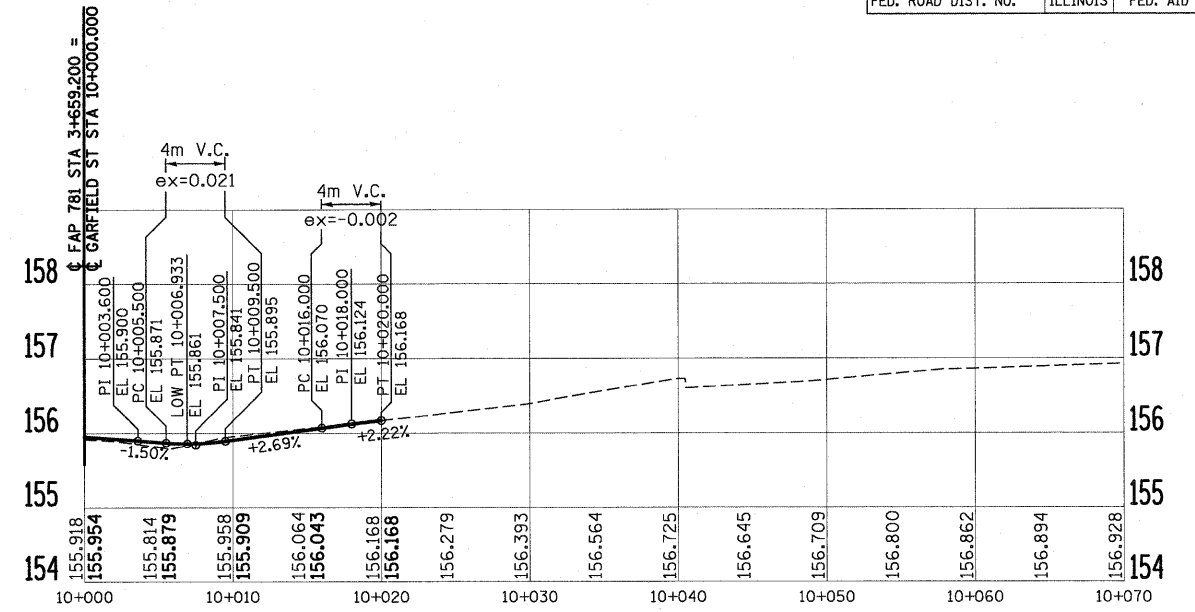

GARFIELD STREET (RT)

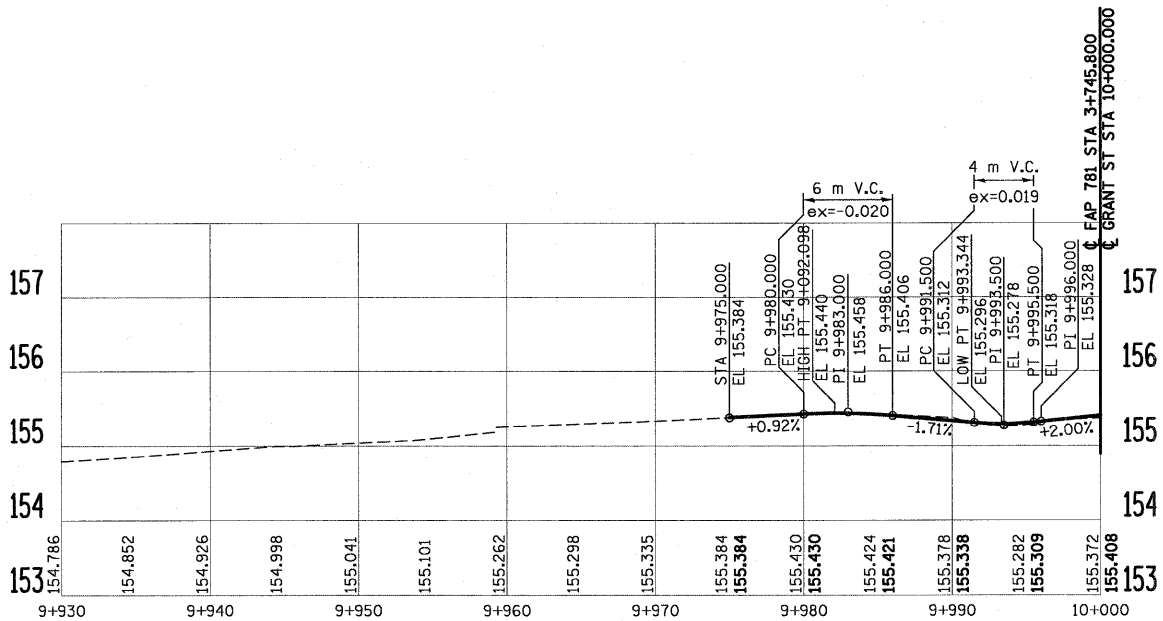

GRANT STREET (LT)

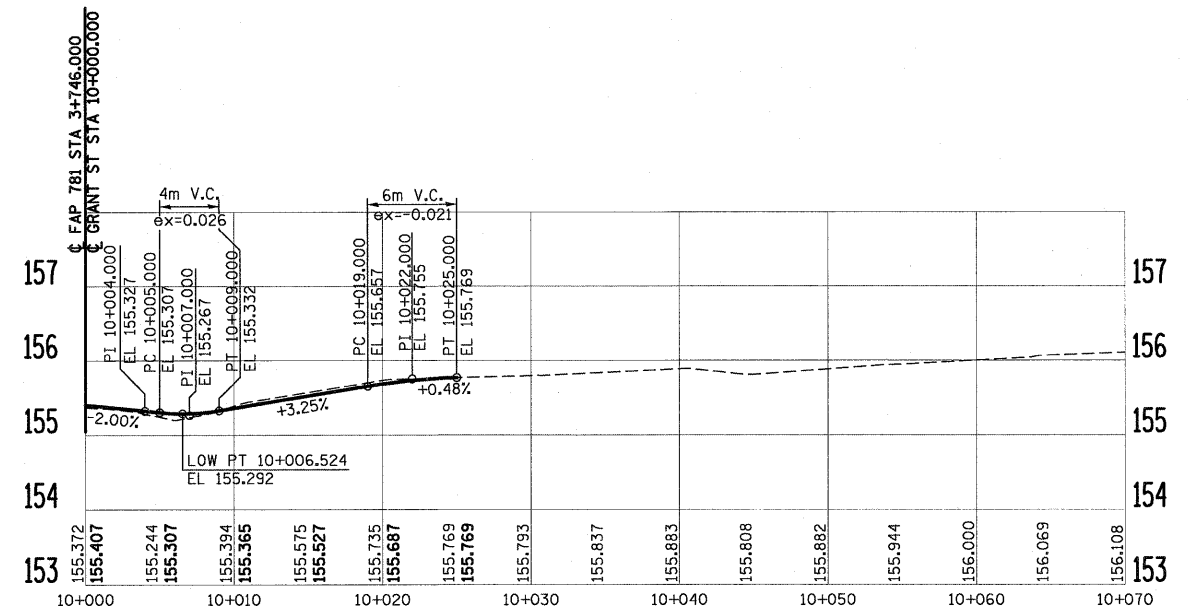

GRANT STREET (RT)

PLOT DATE = 3/20/2008
FILE NAME = H:\4428\781.dwg

REVISIONS		ILLINOIS DEPARTMENT OF TRANSPORTATION
NAME	DATE	
		PROPOSED SIDE ROAD PROFILES SCALE AS SHOWN DRAWN BY EDW DATE MARCH 20, 2008 CHECKED BY RGH

F.A.P. RTE.	SECTION	COUNTY	TOTAL SHEETS	SHEET NO.
781	1YRS, 2ZRS-1	CRAWFORD	378	142
STA.		TO STA.		
FED. ROAD DIST. NO.		ILLINOIS	FED. AID PROJECT	

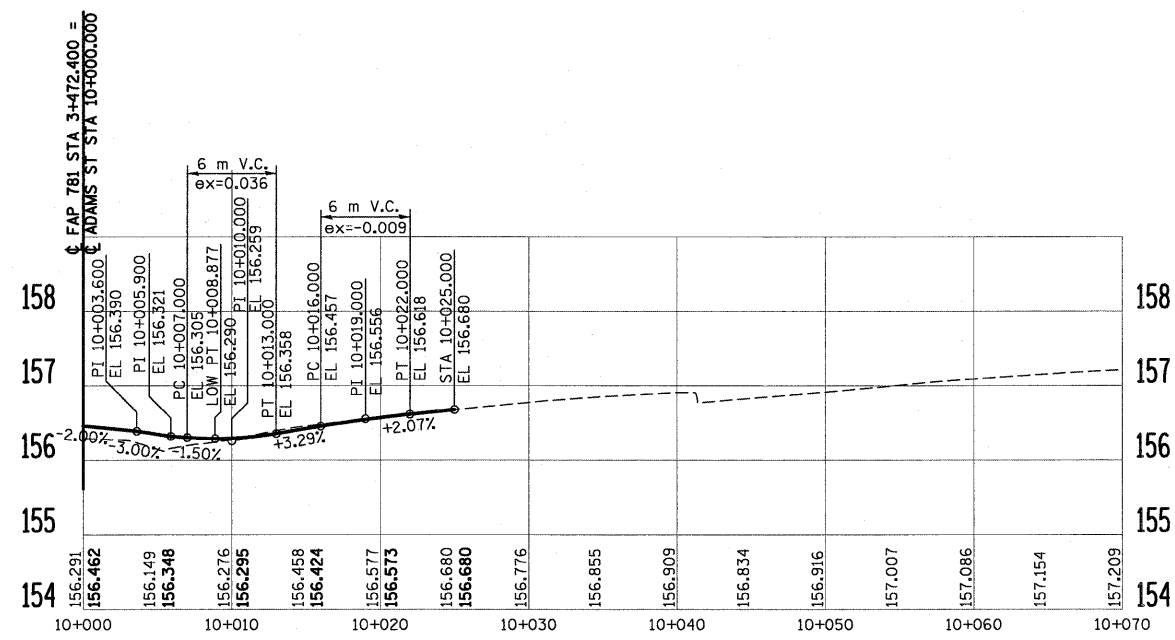

ADAMS STREET (RT)

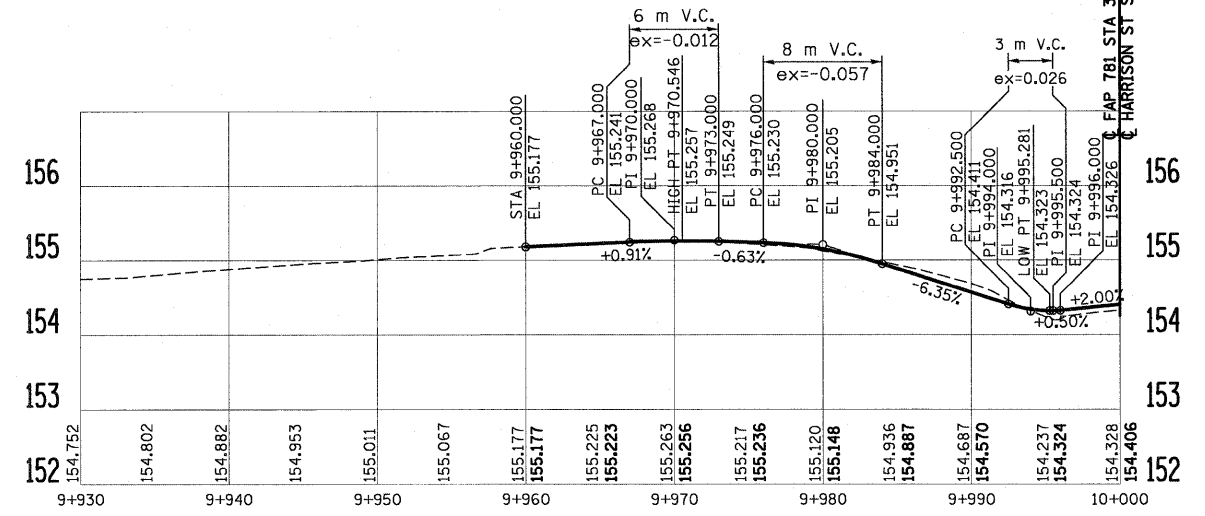

HARRISON STREET (LT)

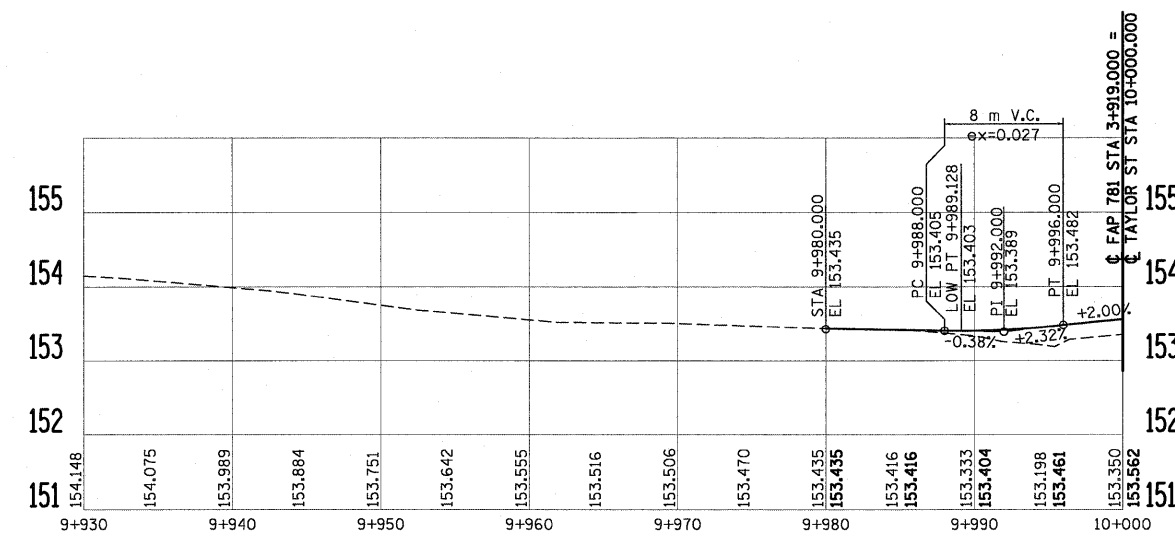

TAYLOR STREET (LT)

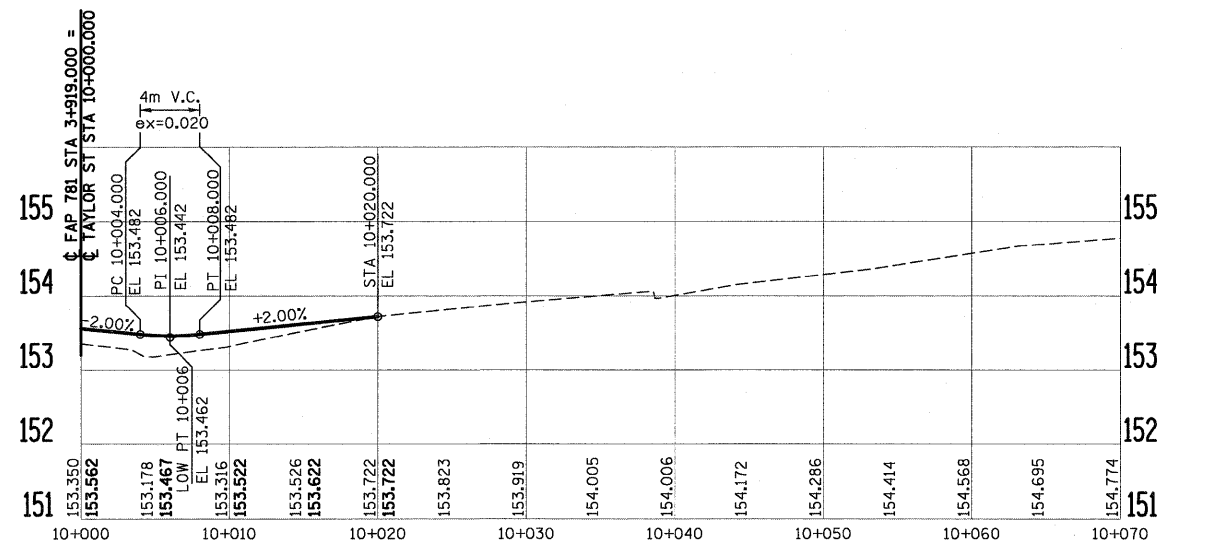

TAYLOR STREET (RT)

PLOT DATE = 3/20/2008
FILE NAME = H:\4420\781\42\prop\786.dgn

REVISIONS	
NAME	DATE

ILLINOIS DEPARTMENT OF TRANSPORTATION
PROPOSED SIDE ROAD PROFILES
SCALE AS SHOWN DRAWN BY EDW
DATE MARCH 20, 2008 CHECKED BY RGH

F.A.P. RTE.	SECTION	COUNTY	TOTAL SHEETS	SHEET NO.
781	1YRS, 2ZRS-1	CRAWFORD	378	143
STA.		TO STA.		
FED. ROAD DIST. NO.	ILLINOIS	FED. AID PROJECT		

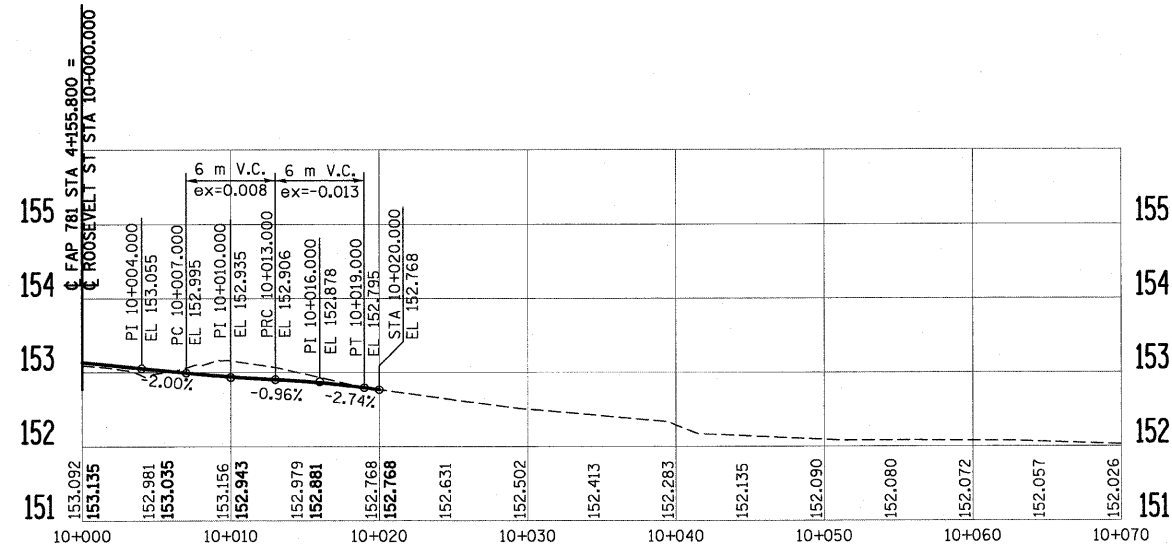

ROOSEVELT STREET (RT)

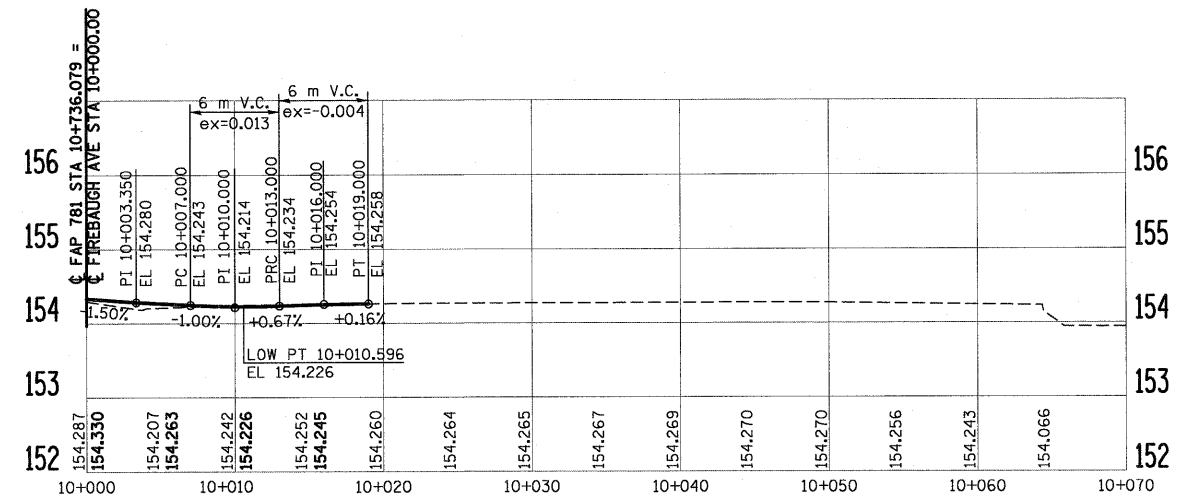

FIREBAUGH AVE. (RT.)

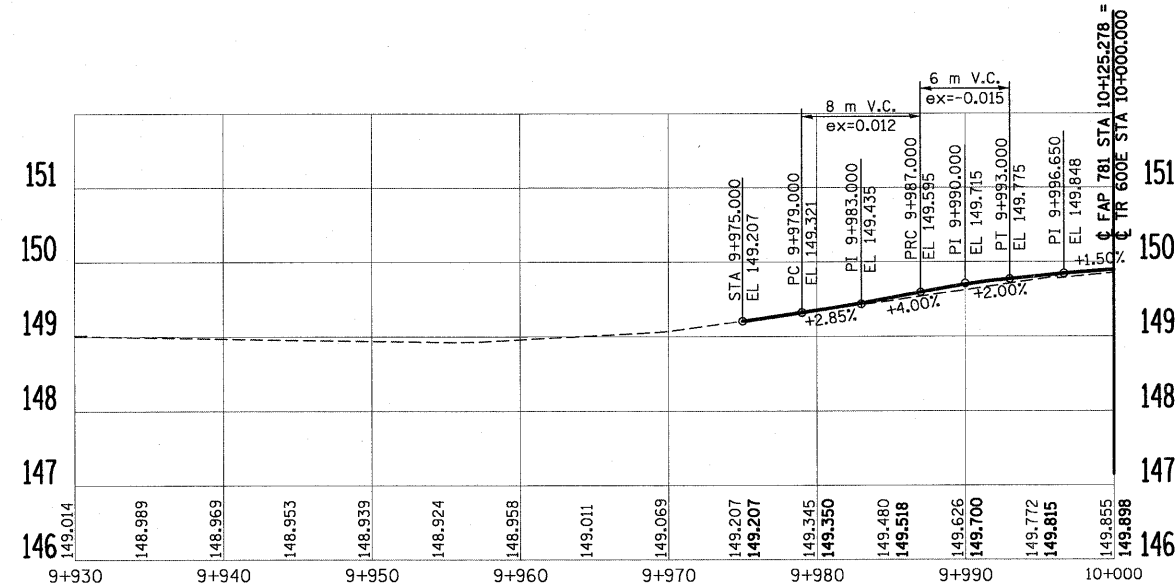

STOY RD. TR 600 E (LT.)

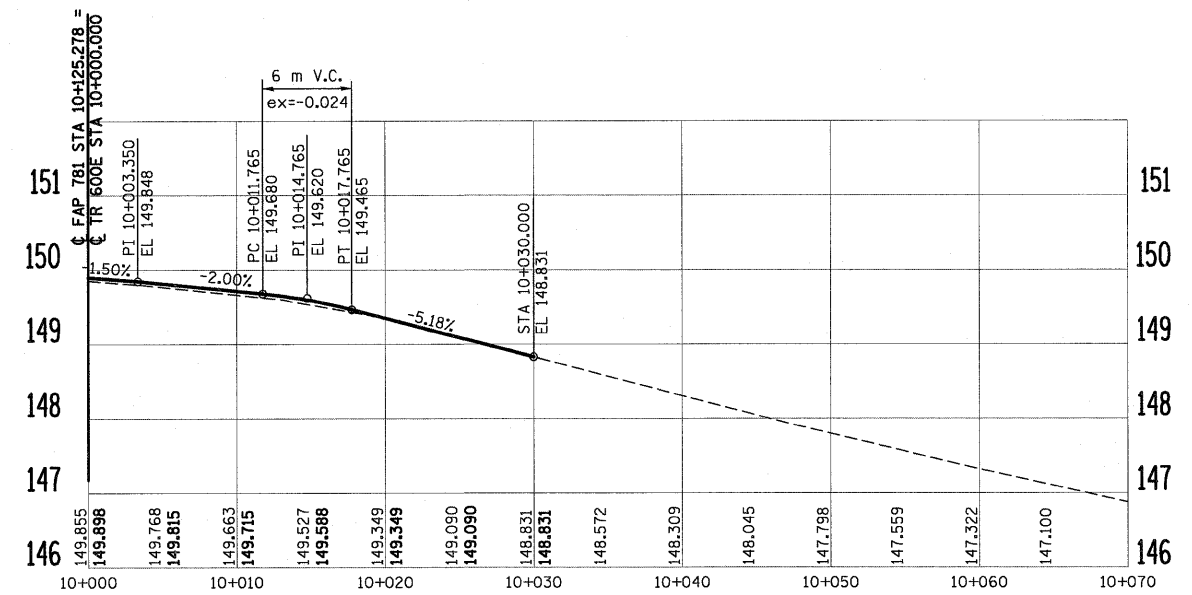

STOY RD. TR 600 E (RT.)

PLOT DATE = 3/20/2008
FILE NAME = H:\1428\7014.3.prf07.dgn

REVISIONS		ILLINOIS DEPARTMENT OF TRANSPORTATION
NAME	DATE	
		PROPOSED SIDE ROAD PROFILES SCALE AS SHOWN DRAWN BY EDW DATE MARCH 20, 2008 CHECKED BY RGH

F.A.P. RTE.	SECTION	COUNTY	TOTAL SHEETS	SHEET NO.
781	1YRS, 2ZRS-1	CRAWFORD	378	144
STA.		TO STA.		
FED. ROAD DIST. NO.		ILLINOIS	FED. AID PROJECT	

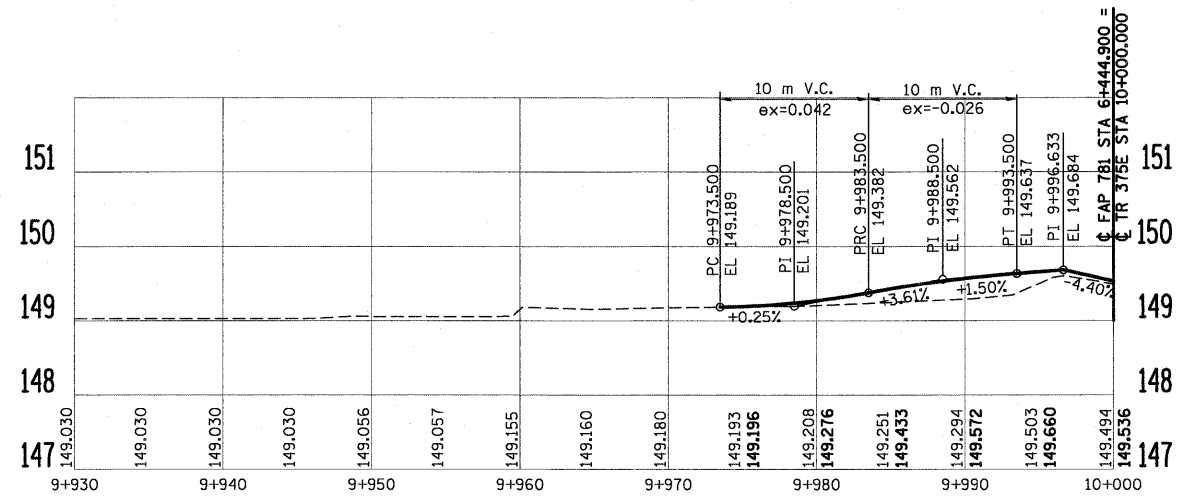

TR 375 (LT)

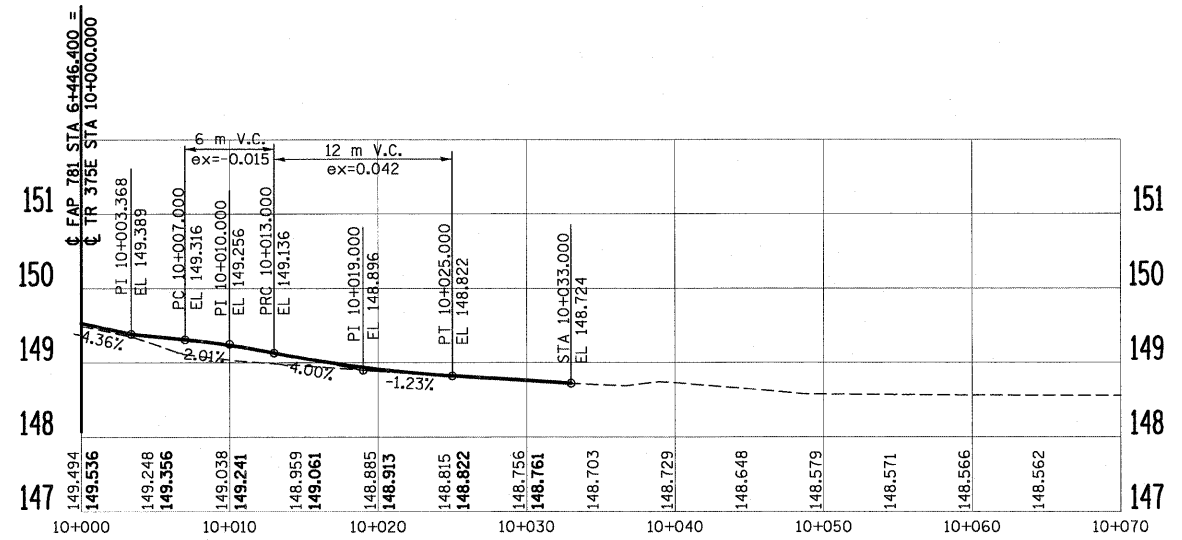

TR 375E (RT)

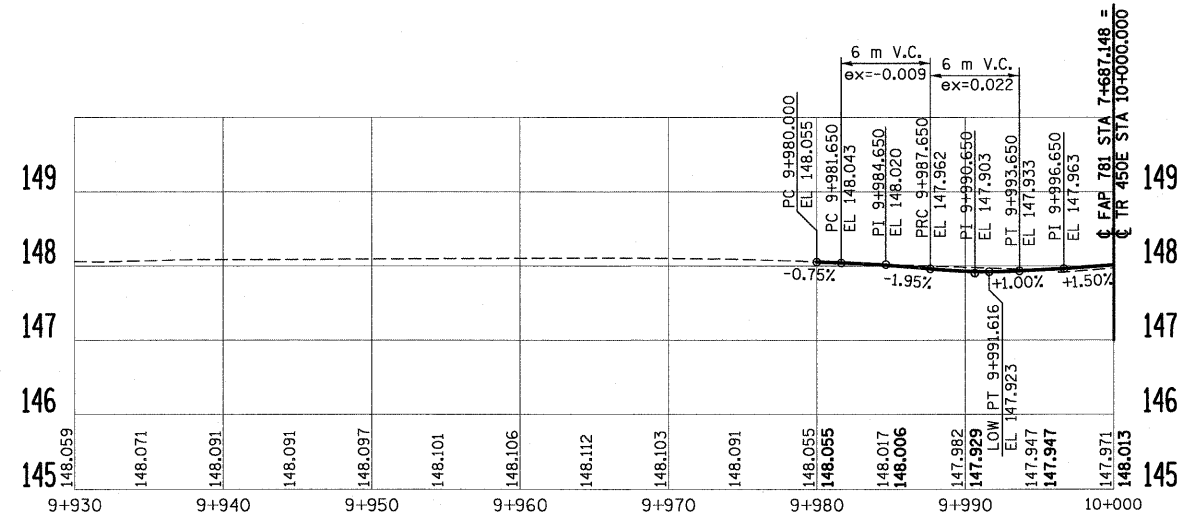

TR 450E (LT)

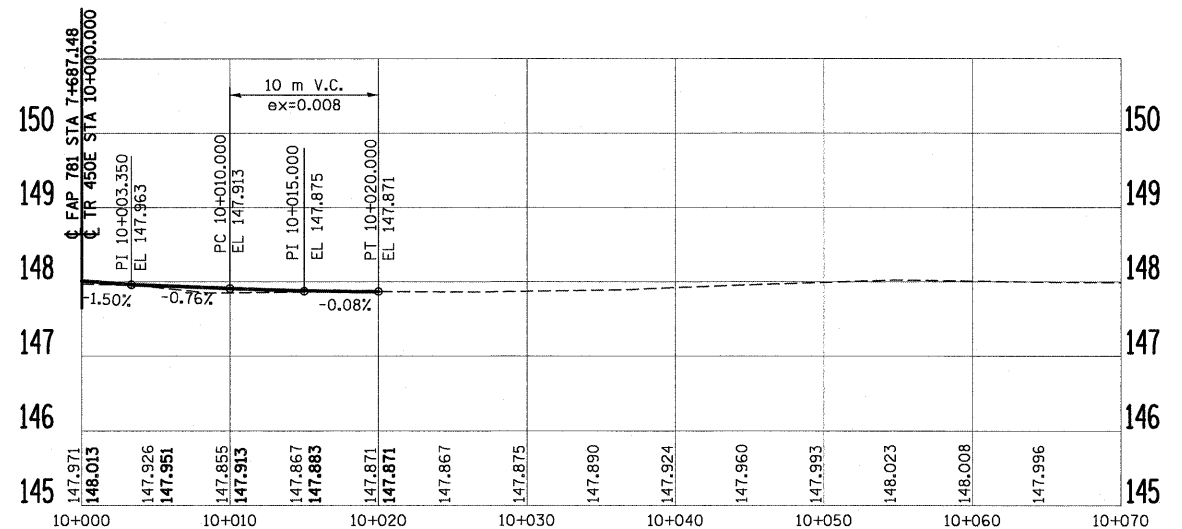

TR 450E (RT)

PLOT DATE = 3/20/2008
FILE NAME = H:\4428\78144_spr108.dgn

REVISIONS		ILLINOIS DEPARTMENT OF TRANSPORTATION
NAME	DATE	
		PROPOSED SIDE ROAD PROFILES SCALE AS SHOWN DRAWN BY EDW DATE MARCH 20, 2008 CHECKED BY RGH

F.A.P. RTE.	SECTION	COUNTY	TOTAL SHEETS	SHEET NO.
781	1YRS, 2ZRS-1	CRAWFORD	378	145
STA.		TO STA.		
FED. ROAD DIST. NO.		ILLINOIS	FED. AID PROJECT	

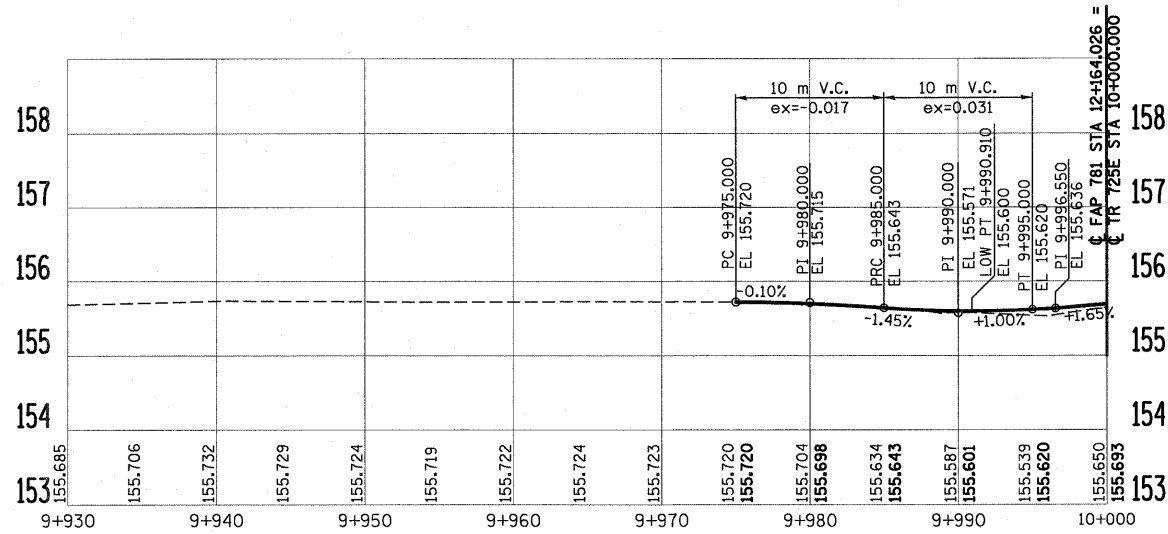

TR 725 E (LT.)

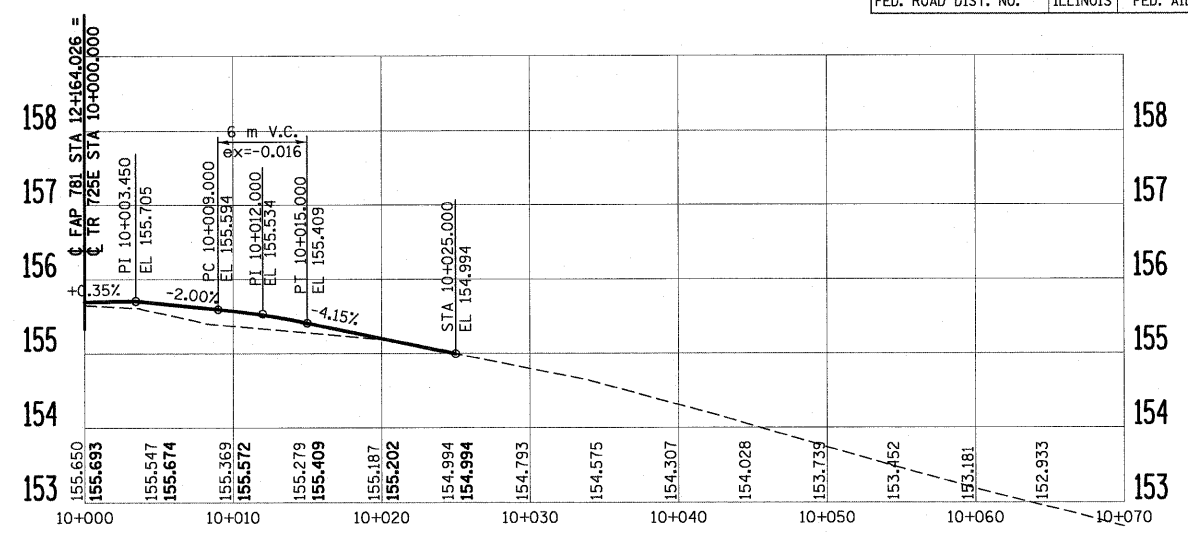

TR 725 E (RT.)

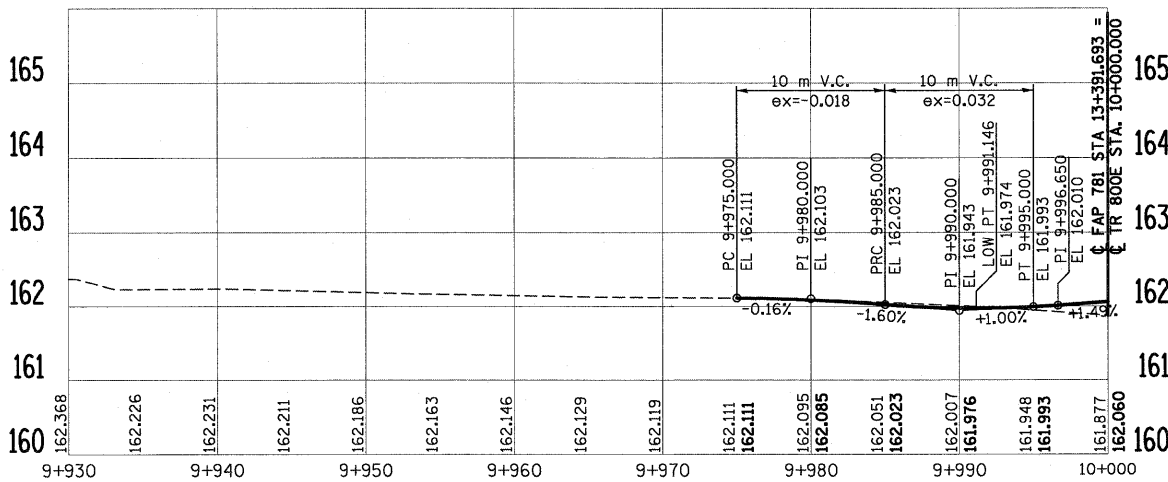

TR 800 E (LT.)

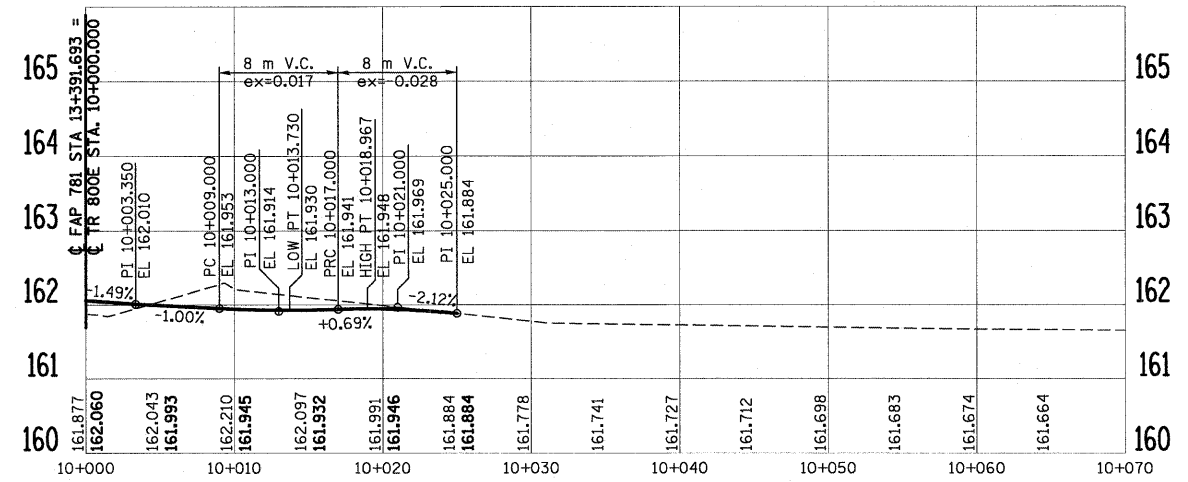

TR 800 E (RT.)

PLOT DATE = 3/20/2008
FILE NAME = H:\4420\70145_prrf03.dgn

REVISIONS		ILLINOIS DEPARTMENT OF TRANSPORTATION
NAME	DATE	
		PROPOSED SIDE ROAD PROFILES SCALE AS SHOWN DRAWN BY EDW DATE MARCH 20, 2008 CHECKED BY RGH

F.A.P. RTE.	SECTION	COUNTY	TOTAL SHEETS	SHEET NO.
781	1YRS, 2ZRS-1	CRAWFORD	378	146
STA.		TO STA.		
FED. ROAD DIST. NO.	ILLINOIS	FED. AID PROJECT		

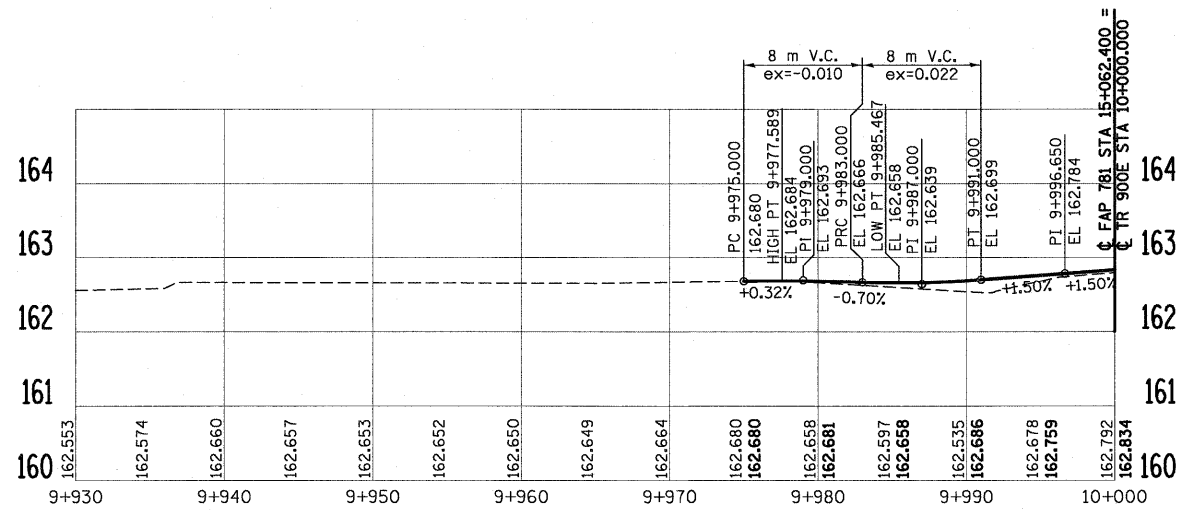

TR 900E (LT.)

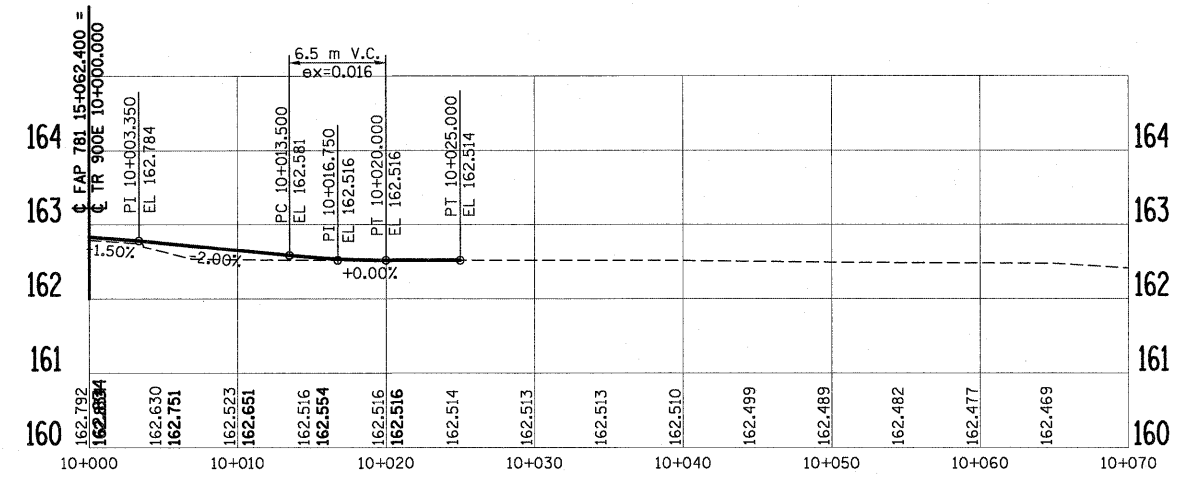

TR 900E (RT.)

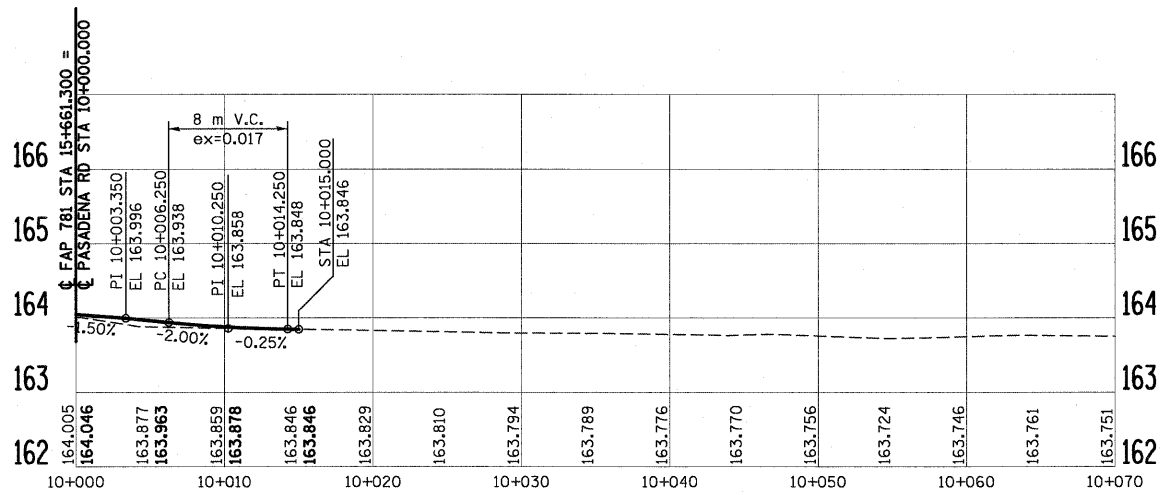

PASADENA RD. (RT.)

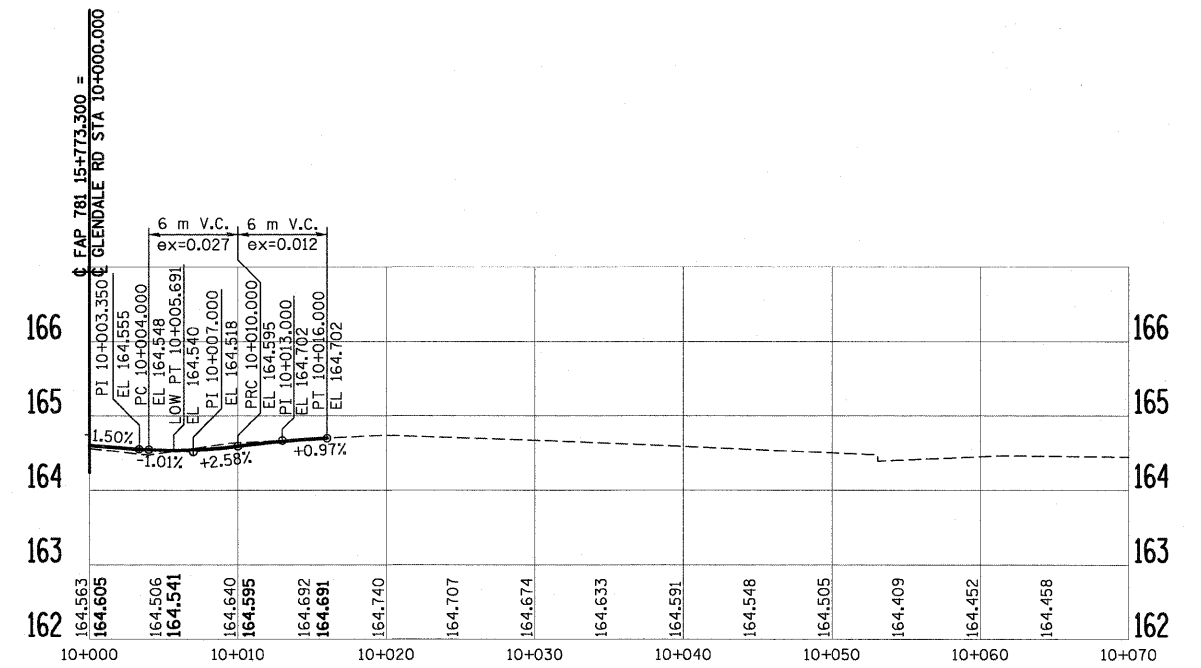

GLENDALE RD. (RT.)

PLOT DATE = 3/20/2008
FILE NAME = H:\4428\70146_sprf10.dgn

REVISIONS		ILLINOIS DEPARTMENT OF TRANSPORTATION
NAME	DATE	
		<p>PROPOSED SIDE ROAD PROFILES</p> <p>SCALE AS SHOWN DRAWN BY EDW</p> <p>DATE MARCH 20, 2008 CHECKED BY RGH</p>

F.A.P. RTE.	SECTION	COUNTY	TOTAL SHEETS	SHEET NO.
781	1YRS, 2ZRS-1	CRAWFORD	378	147
STA.		TO STA.		
FED. ROAD DIST. NO.		ILLINOIS	FED. AID PROJECT	

STA. 1+970.300 TL. RTE. 33 =
STA. 10+00.000 TRI00E

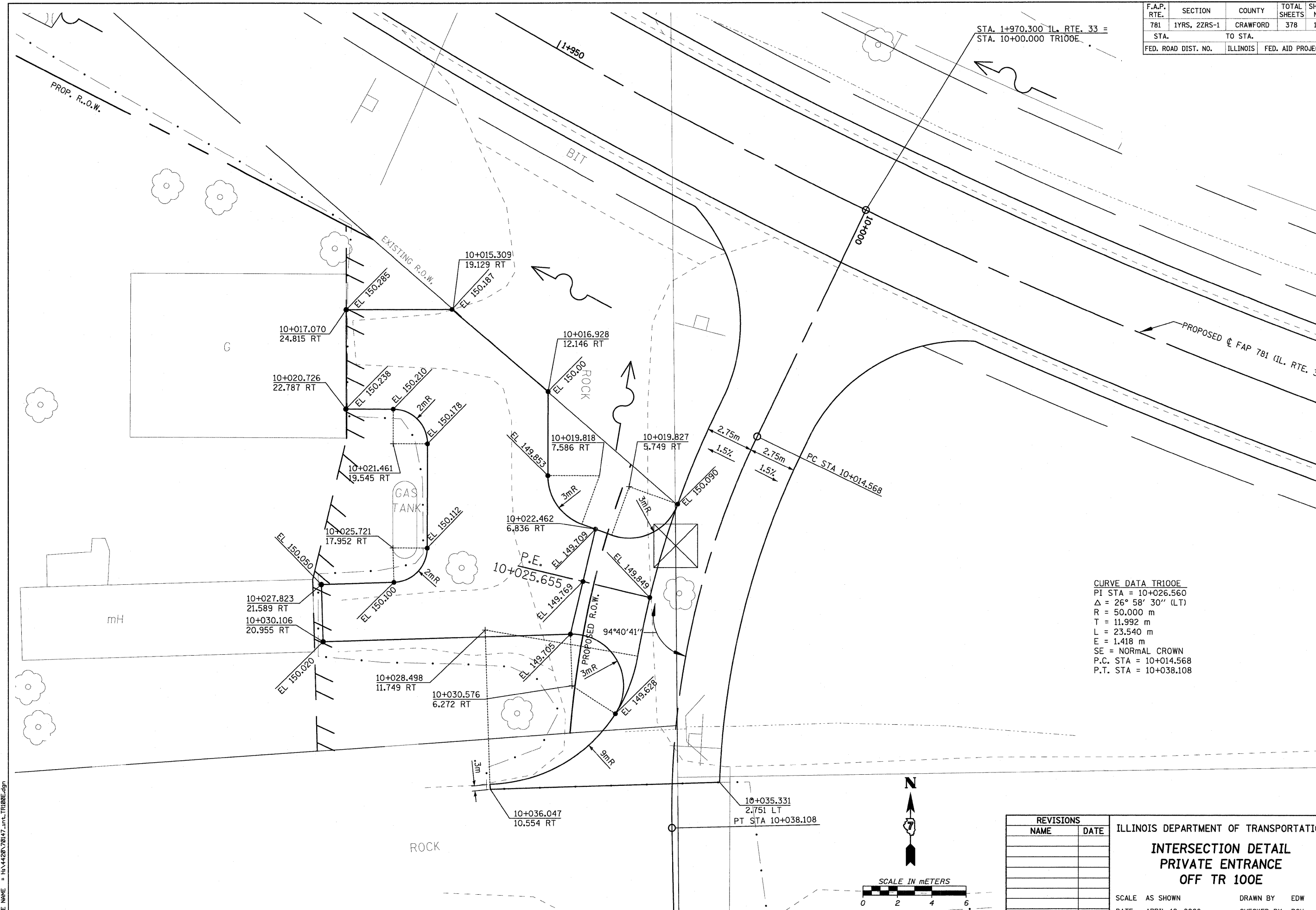

CURVE DATA TRI00E
 PI STA = 10+026.560
 $\Delta = 26^\circ 58' 30''$ (LT)
 R = 50.000 m
 T = 11.992 m
 L = 23.540 m
 E = 1.418 m
 SE = NORMAL CROWN
 P.C. STA = 10+014.568
 P.T. STA = 10+038.108

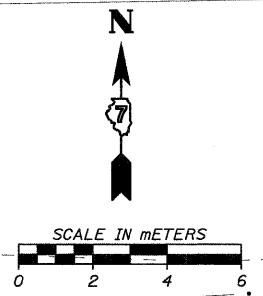

REVISIONS	
NAME	DATE

ILLINOIS DEPARTMENT OF TRANSPORTATION
INTERSECTION DETAIL
PRIVATE ENTRANCE
OFF TR 100E
 SCALE AS SHOWN
 DATE APRIL 18, 2008
 DRAWN BY EDW
 CHECKED BY RGH

PLOT DATE = 4/18/2008
 FILE NAME = H:\4420\78147_int_L_TR100E.dgn

H. M. & G. NO. 4420

F.A.P. RTE.	SECTION	COUNTY	TOTAL SHEETS	SHEET NO.
781	1YRS, 2ZRS-1	CRAWFORD	378	149
STA.		TO STA.		
FED. ROAD DIST. NO.		ILLINOIS	FED. AID PROJECT	

LEGEND

- CONTRACTION JOINT PER STD. 420001
- LONGITUDINAL JOINT PER STD. 420001
THE LONGITUDINAL METAL JOINT TYPE C MAY BE USED FOR SEPERATE LANE POURS, THE LONGITUDINAL JOINT WILL NOT BE SAWED WITH SEPERATE LANE POURS.
- 595.555 PROPOSED SURFACE ELEVATION

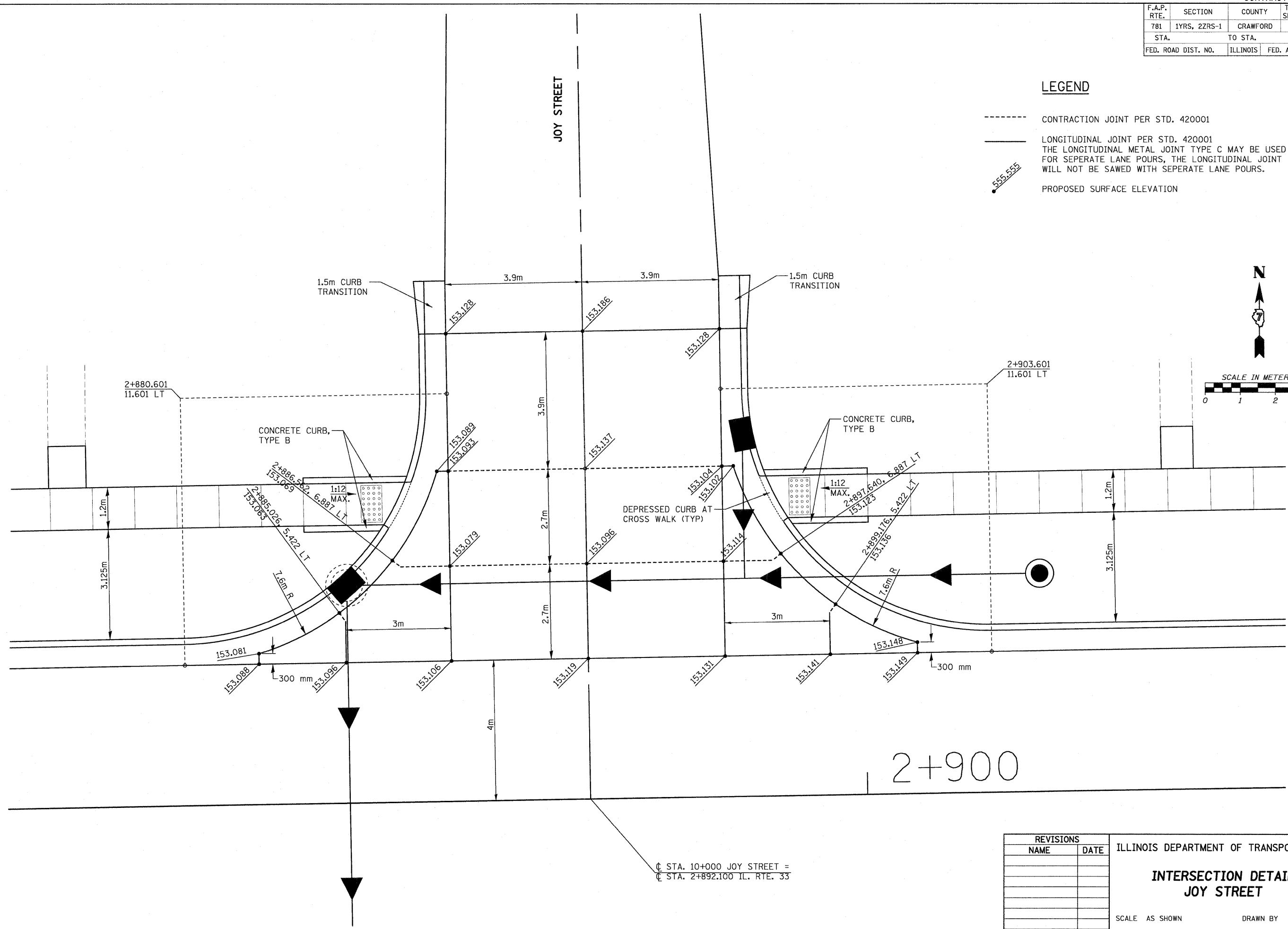
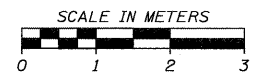

⚬ STA. 10+000 JOY STREET =
 ⚬ STA. 2+892.100 IL. RTE. 33

REVISIONS	
NAME	DATE

ILLINOIS DEPARTMENT OF TRANSPORTATION

**INTERSECTION DETAIL
JOY STREET**

SCALE AS SHOWN DRAWN BY EDW
DATE MARCH 20, 2008 CHECKED BY RGH

PLOT DATE = 3/20/2008
 FILE NAME = H:\4420\78149_int_joy.dgn

H. M. & G. NO. 4420

F.A.P. RTE.	SECTION	COUNTY	TOTAL SHEETS	SHEET NO.
781	1YRS, 2ZRS-1	CRAWFORD	378	150
STA.		TO STA.		
FED. ROAD DIST. NO.		ILLINOIS	FED. AID PROJECT	

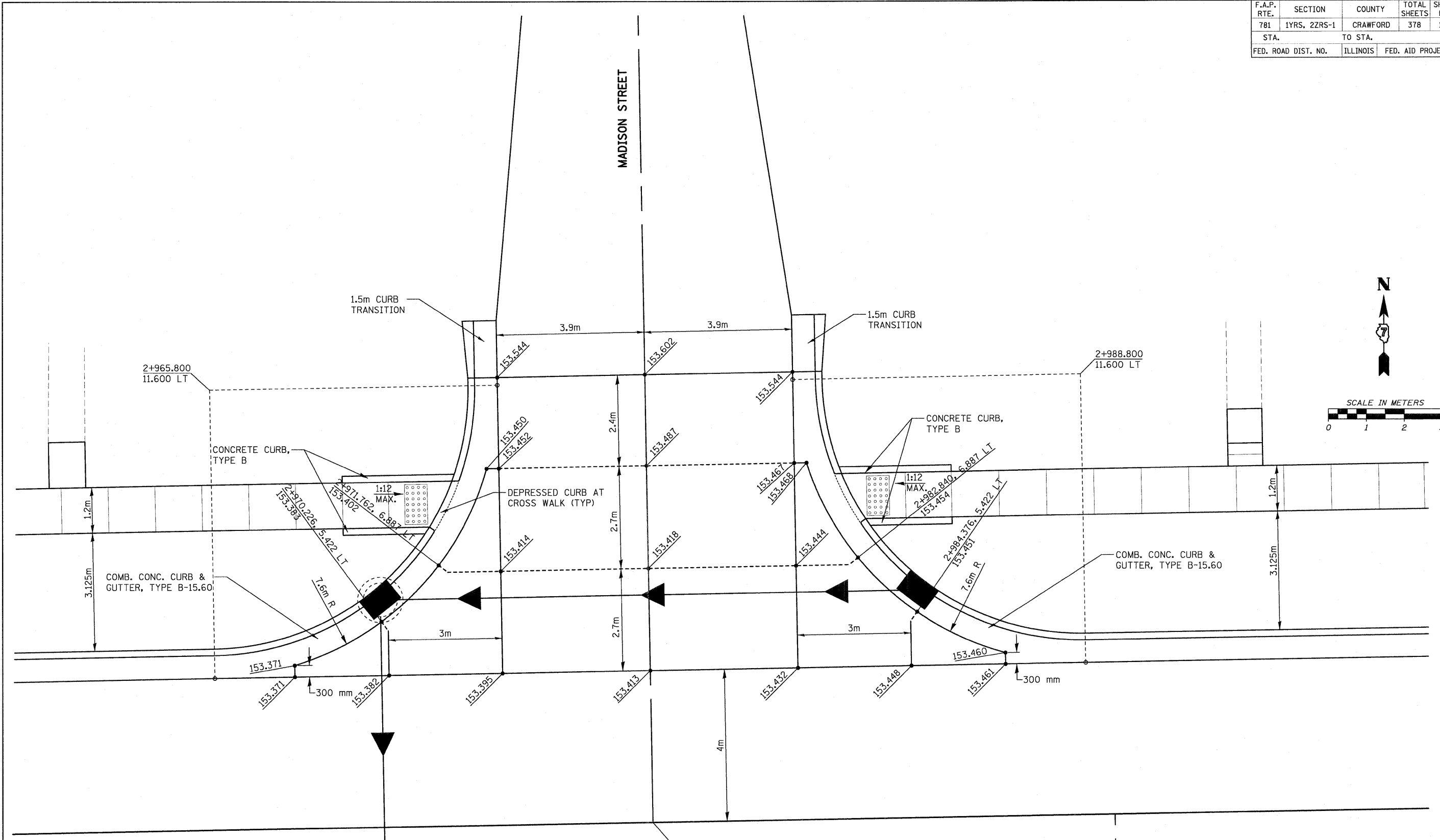

C STA. 10+000 MADISON STREET =
 C STA. 2+977.300 IL. RTE. 33

LEGEND

- CONTRACTION JOINT PER STD. 420001
- LONGITUDINAL JOINT PER STD. 420001
THE LONGITUDINAL METAL JOINT TYPE C MAY BE USED FOR SEPARATE LANE POURS, THE LONGITUDINAL JOINT WILL NOT BE SAWS WITH SEPARATE LANE POURS.
- 555.555 PROPOSED SURFACE ELEVATION

REVISIONS	
NAME	DATE

ILLINOIS DEPARTMENT OF TRANSPORTATION

**INTERSECTION DETAIL
MADISON STREET**

SCALE AS SHOWN DRAWN BY EDW
 DATE MARCH 20, 2008 CHECKED BY RGH

PLOT DATE = 3/20/2008
 FILE NAME = H:\44207\0150_int_MadisonNcdgn

H. M. & G. NO. 4420

F.A.P. RTE.	SECTION	COUNTY	TOTAL SHEETS	SHEET NO.
781	1YRS, 2ZRS-1	CRAWFORD	378	151
STA.		TO STA.		
FED. ROAD DIST. NO.		ILLINOIS	FED. AID PROJECT	

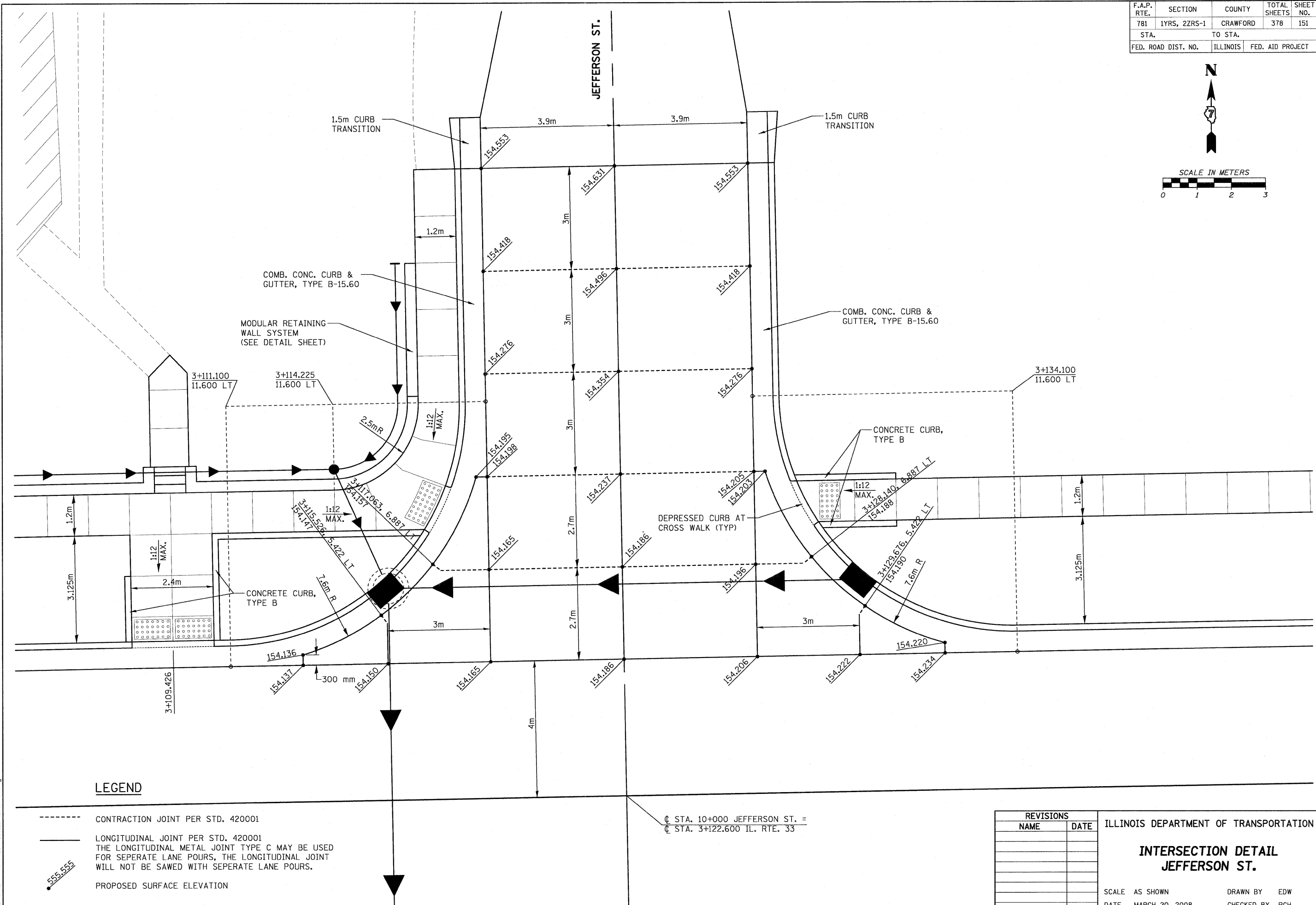

LEGEND

- CONTRACTION JOINT PER STD. 420001
- LONGITUDINAL JOINT PER STD. 420001
THE LONGITUDINAL METAL JOINT TYPE C MAY BE USED FOR SEPERATE LANE POURS, THE LONGITUDINAL JOINT WILL NOT BE SAWED WITH SEPERATE LANE POURS.
- PROPOSED SURFACE ELEVATION

⊕ STA. 10+000 JEFFERSON ST. =
⊕ STA. 3+122.600 IL. RTE. 33

REVISIONS	
NAME	DATE

ILLINOIS DEPARTMENT OF TRANSPORTATION

**INTERSECTION DETAIL
JEFFERSON ST.**

SCALE AS SHOWN DRAWN BY EDW
DATE MARCH 20, 2008 CHECKED BY RGH

PLOT DATE = 3/20/2008
FILE NAME = HV442870151.mxd_jeffan.dgn

H. M. & G. NO. 4420

F.A.P. RTE.	SECTION	COUNTY	TOTAL SHEETS	SHEET NO.
781	1YRS, 2ZRS-1	CRAWFORD	378	152
STA.		TO STA.		
FED. ROAD DIST. NO.		ILLINOIS	FED. AID PROJECT	

C STA. 10+000 JEFFERSON ST. =
C STA. 3+122.600 IL. RTE. 33

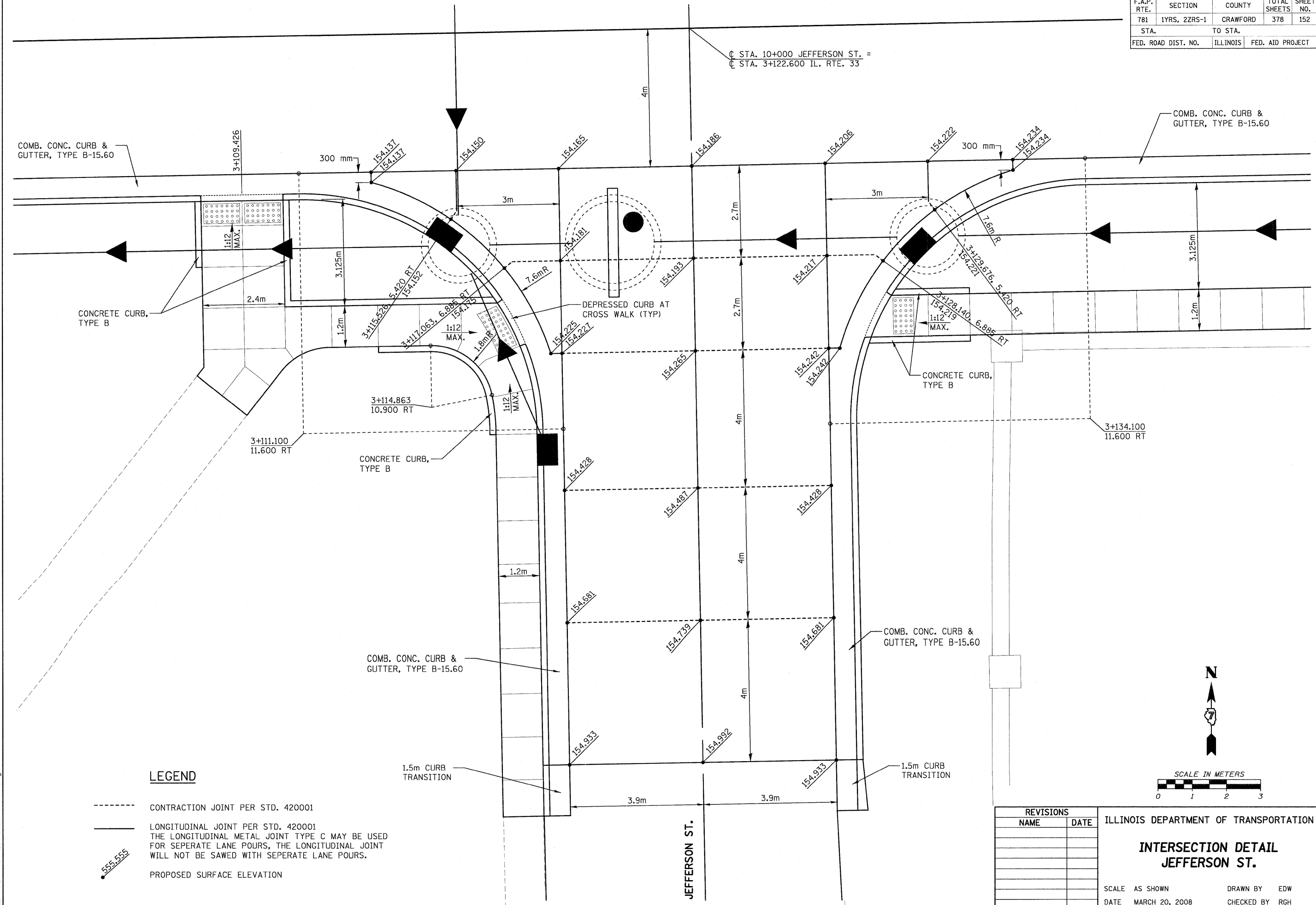

LEGEND

- CONTRACTION JOINT PER STD. 420001
- LONGITUDINAL JOINT PER STD. 420001
THE LONGITUDINAL METAL JOINT TYPE C MAY BE USED FOR SEPERATE LANE POURS, THE LONGITUDINAL JOINT WILL NOT BE SAWED WITH SEPERATE LANE POURS.
- 555.535 PROPOSED SURFACE ELEVATION

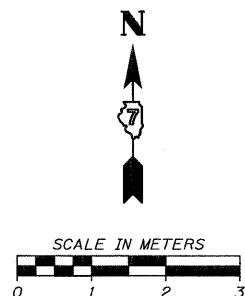

REVISIONS	
NAME	DATE

ILLINOIS DEPARTMENT OF TRANSPORTATION
**INTERSECTION DETAIL
JEFFERSON ST.**
SCALE AS SHOWN DRAWN BY EDW
DATE MARCH 20, 2008 CHECKED BY RGH

PLOT DATE = 3/20/2008
FILE NAME = H:\14428\70152_int_JeffSt.dgn

H. M. & C. NO. 4420

F.A.P. RTE.	SECTION	COUNTY	TOTAL SHEETS	SHEET NO.
781	1YRS, 2ZRS-1	CRAWFORD	378	153
STA.		TO STA.		
FED. ROAD DIST. NO.		ILLINOIS	FED. AID PROJECT	

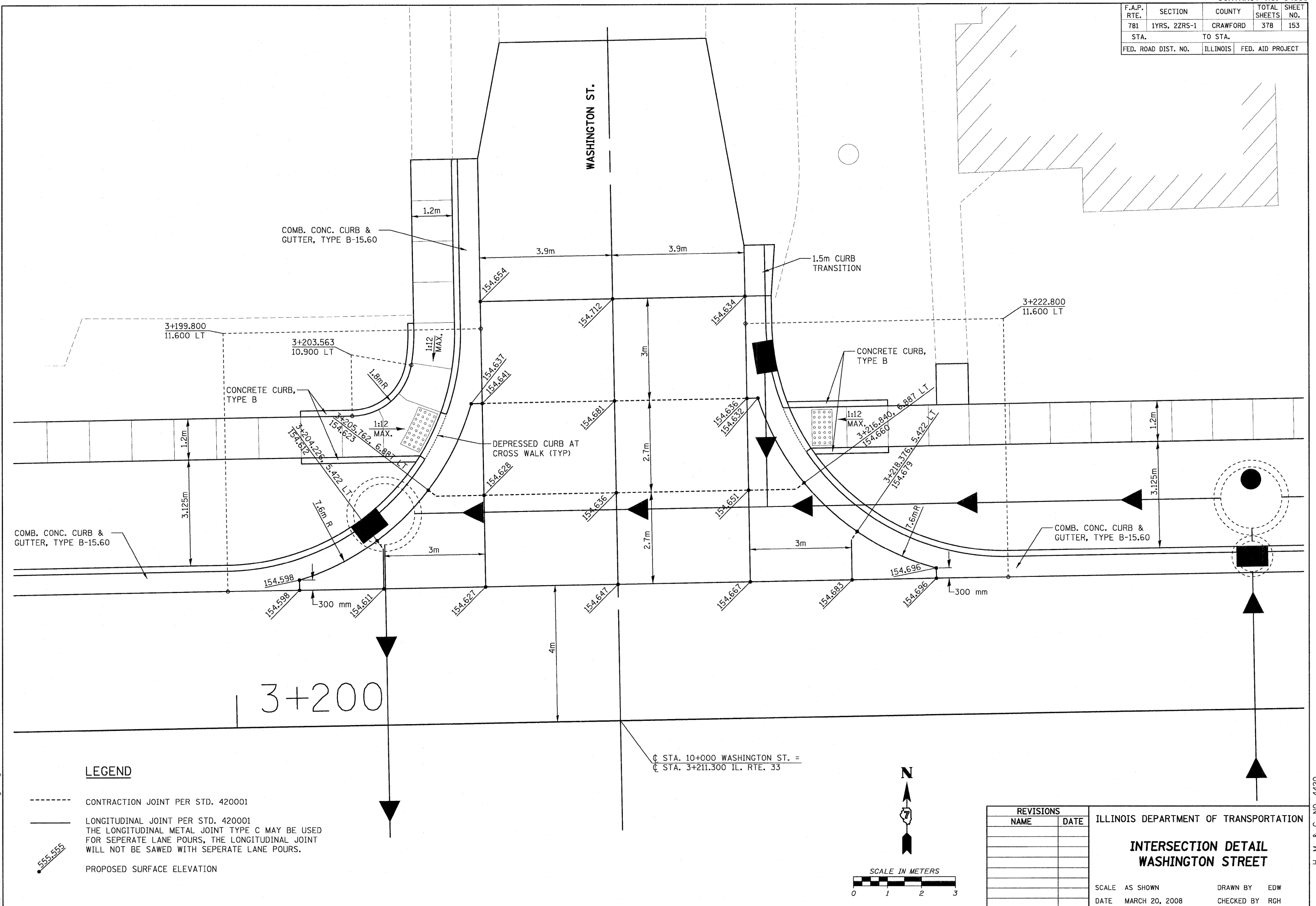

LEGEND

- CONTRACTION JOINT PER STD. 420001
- LONGITUDINAL JOINT PER STD. 420001
THE LONGITUDINAL METAL JOINT TYPE C MAY BE USED FOR SEPERATE LANE POURS, THE LONGITUDINAL JOINT WILL NOT BE SAWed WITH SEPERATE LANE POURS.
- PROPOSED SURFACE ELEVATION

REVISIONS	
NAME	DATE

ILLINOIS DEPARTMENT OF TRANSPORTATION

**INTERSECTION DETAIL
WASHINGTON STREET**

SCALE AS SHOWN DRAWN BY EDW
DATE MARCH 20, 2008 CHECKED BY RGH

PLOT DATE = 3/20/2008
FILE NAME = H:\442078\94533\int.L\Washington.dgn

H. M. & C. NO. 4420

F.A.P. RTE.	SECTION	COUNTY	TOTAL SHEETS	SHEET NO.
781	1YRS, 2ZRS-1	CRAWFORD	378	154
STA.		TO STA.		
FED. ROAD DIST. NO.		ILLINOIS	FED. AID PROJECT	

3+200

⊕ STA. 10+000 WASHINGTON ST. =
⊕ STA. 3+211.300 IL. RTE. 33

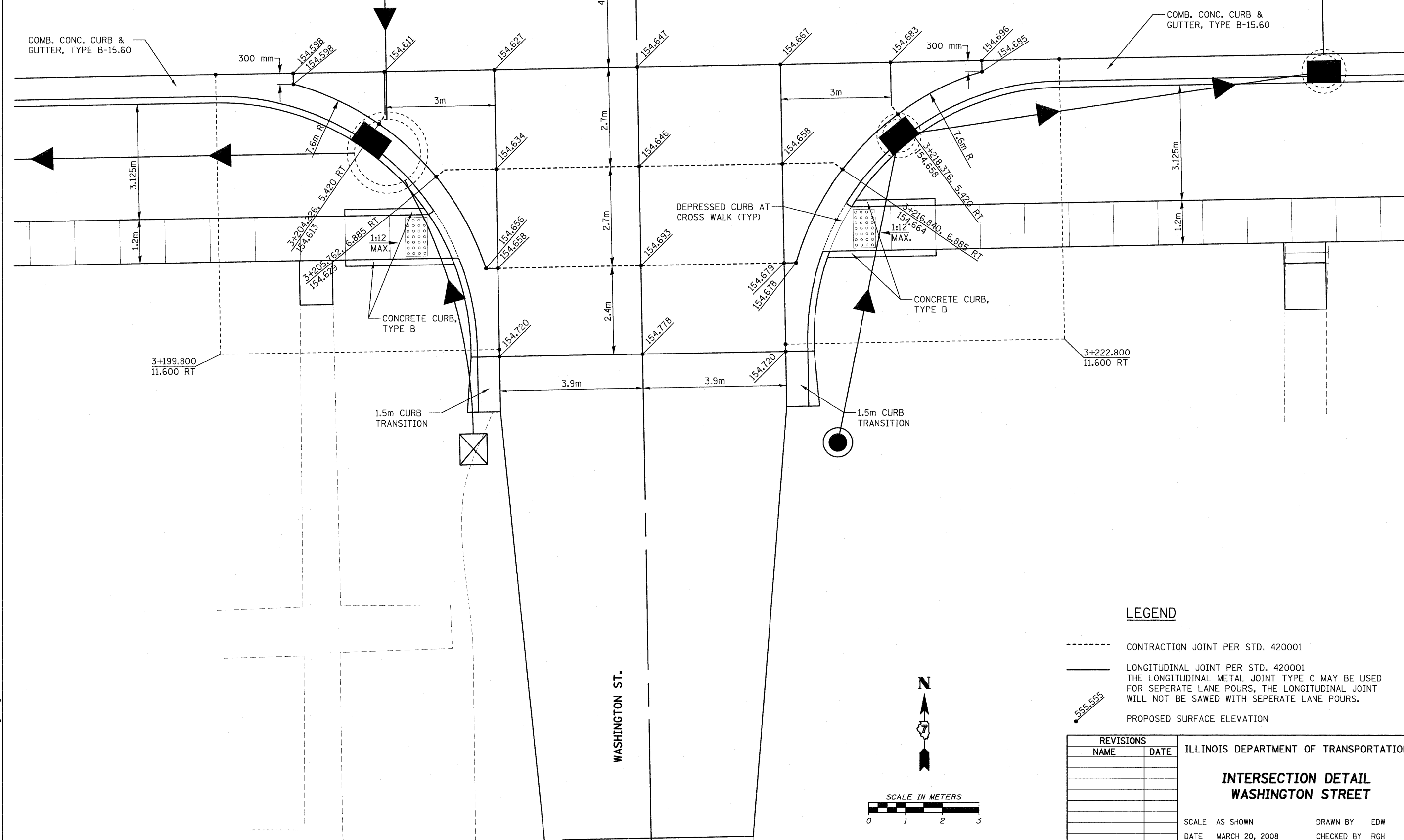

LEGEND

- CONTRACTION JOINT PER STD. 420001
- LONGITUDINAL JOINT PER STD. 420001
- THE LONGITUDINAL METAL JOINT TYPE C MAY BE USED FOR SEPERATE LANE POURS, THE LONGITUDINAL JOINT WILL NOT BE SAWED WITH SEPERATE LANE POURS.
- 555.555 PROPOSED SURFACE ELEVATION

REVISIONS	
NAME	DATE

ILLINOIS DEPARTMENT OF TRANSPORTATION

**INTERSECTION DETAIL
WASHINGTON STREET**

SCALE AS SHOWN DRAWN BY EDW
DATE MARCH 20, 2008 CHECKED BY RGH

PLOT DATE = 3/20/2008
FILE NAME = H:\4420\70154_int.Washington.dgn

H. M. & G. NO. 4420

F.A.P. RTE.	SECTION	COUNTY	TOTAL SHEETS	SHEET NO.
781	1YRS, 2ZRS-1	CRAWFORD	378	155
STA.		TO STA.		
FED. ROAD DIST. NO.		ILLINOIS	FED. AID PROJECT	

LEGEND

- CONTRACTION JOINT PER STD. 420001
- LONGITUDINAL JOINT PER STD. 420001
THE LONGITUDINAL METAL JOINT TYPE C MAY BE USED FOR SEPERATE LANE POURS, THE LONGITUDINAL JOINT WILL NOT BE SAWED WITH SEPERATE LANE POURS.
- 555.555 PROPOSED SURFACE ELEVATION

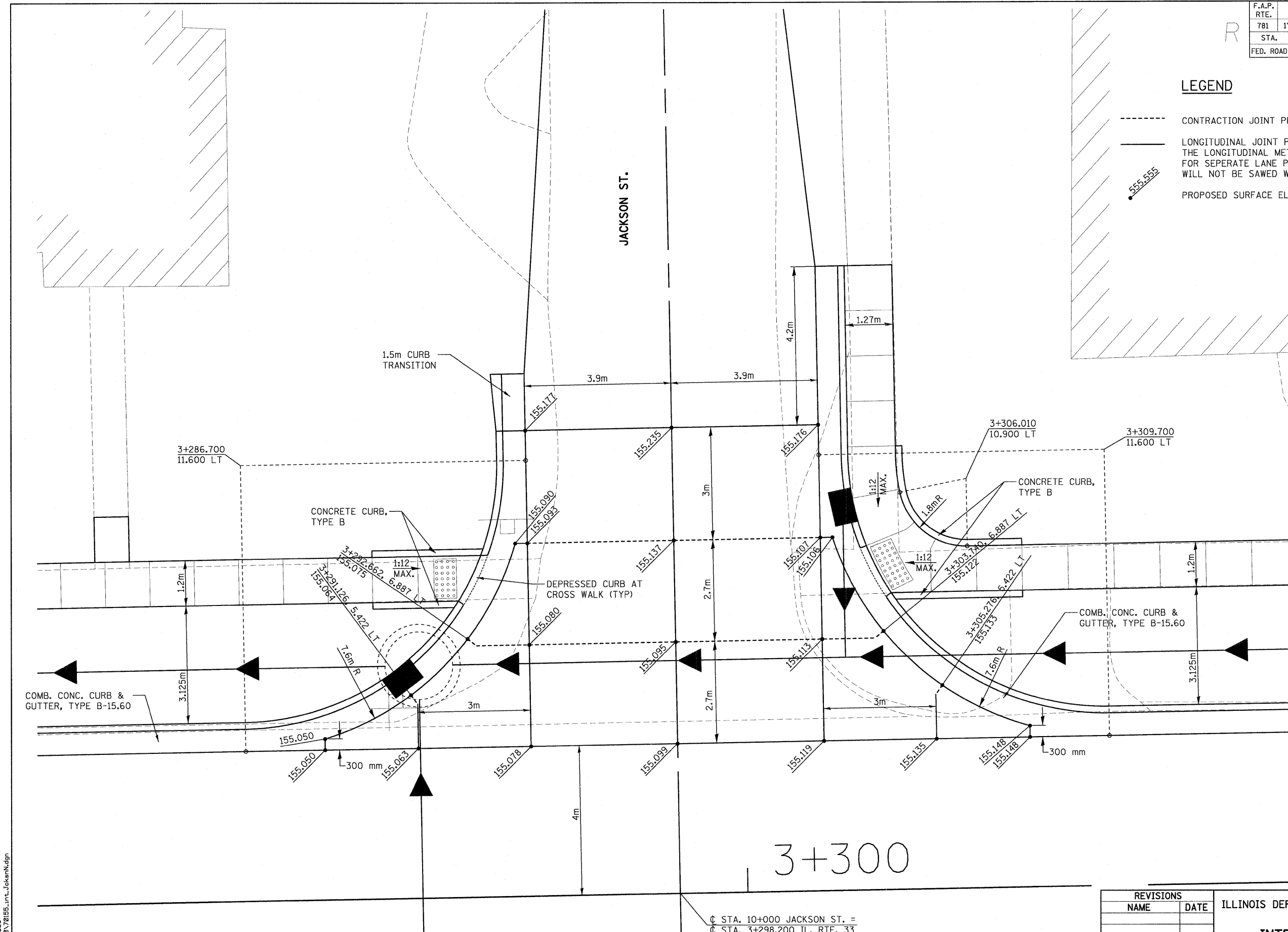

PLOT DATE = 3/20/2008
 FILE NAME = H:\4428\781\155_int_jackson.dgn

C STA. 10+000 JACKSON ST. =
 C STA. 3+298.200 IL. RTE. 33

REVISIONS	
NAME	DATE

ILLINOIS DEPARTMENT OF TRANSPORTATION

**INTERSECTION DETAIL
JACKSON ST.**

SCALE AS SHOWN DRAWN BY EDW
 DATE MARCH 20, 2008 CHECKED BY RGH

H. M. & G. NO. 4420

F.A.P. RTE.	SECTION	COUNTY	TOTAL SHEETS	SHEET NO.
781	1YRS, 2ZRS-1	CRAWFORD	378	156
STA.		TO STA.		
FED. ROAD DIST. NO.		ILLINOIS	FED. AID PROJECT	

± STA. 10+000 JACKSON ST. =
± STA. 3+298.200 IL. RTE. 33

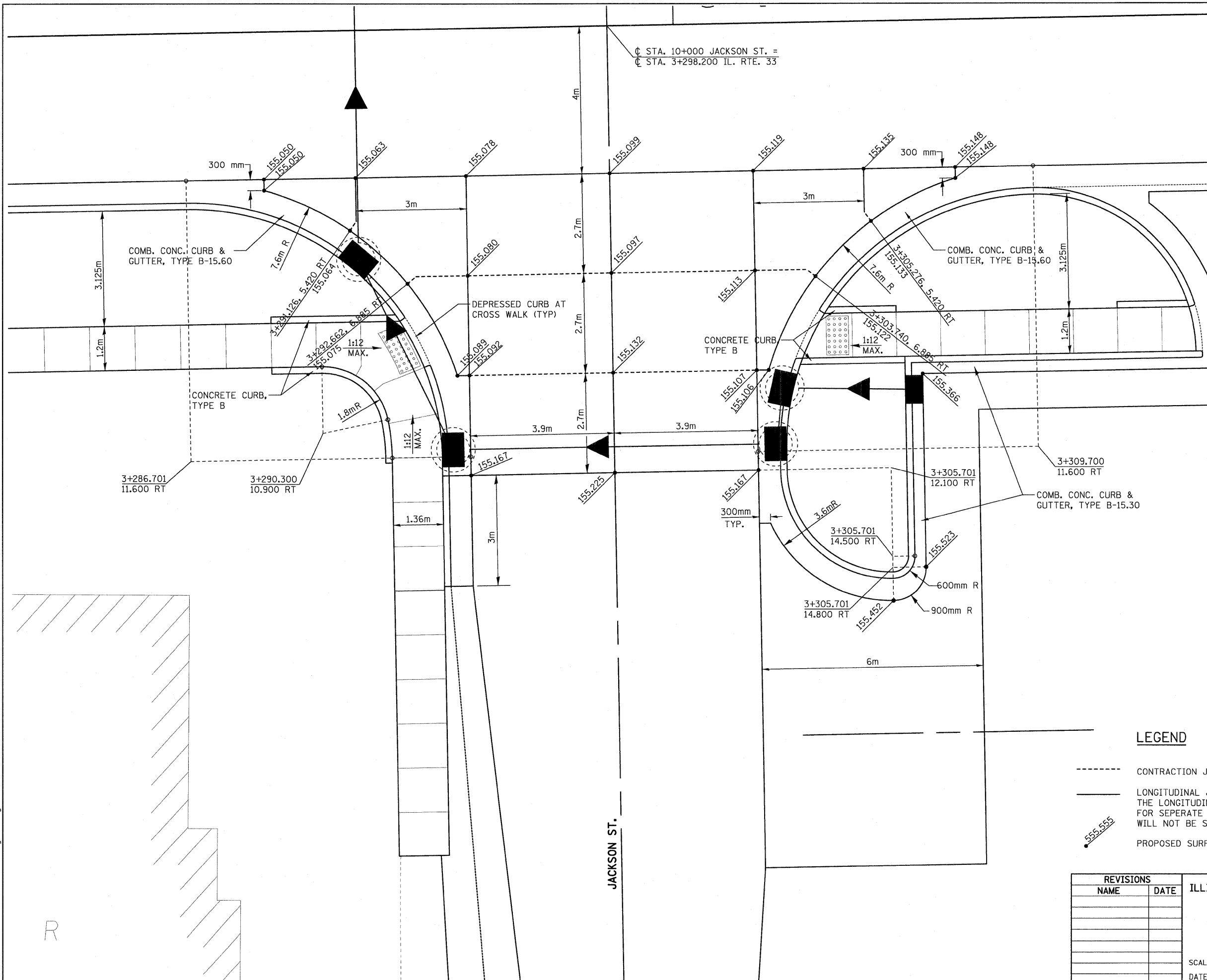

LEGEND

- CONTRACTION JOINT PER STD. 420001
- LONGITUDINAL JOINT PER STD. 420001
THE LONGITUDINAL METAL JOINT TYPE C MAY BE USED FOR SEPERATE LANE POURS, THE LONGITUDINAL JOINT WILL NOT BE SAWED WITH SEPERATE LANE POURS.
- 555.555 PROPOSED SURFACE ELEVATION

REVISIONS	
NAME	DATE

ILLINOIS DEPARTMENT OF TRANSPORTATION

**INTERSECTION DETAIL
JACKSON ST.**

SCALE AS SHOWN DRAWN BY EDW
DATE MARCH 20, 2008 CHECKED BY RGH

PLOT DATE = 3/20/2008
FILE NAME = H:\4420\781\4420\33\plans\pkgs\dgn

H. M. & G. NO. 4420

F.A.P. RTE.	SECTION	COUNTY	TOTAL SHEETS	SHEET NO.
781	1YRS, 2ZRS-1	CRAWFORD	378	157
STA.		TO STA.		
FED. ROAD DIST. NO.		ILLINOIS	FED. AID PROJECT	

LEGEND

- CONTRACTION JOINT PER STD. 420001
- LONGITUDINAL JOINT PER STD. 420001
- 555.555 THE LONGITUDINAL METAL JOINT TYPE C MAY BE USED FOR SEPERATE LANE POURS, THE LONGITUDINAL JOINT WILL NOT BE SAWED WITH SEPERATE LANE POURS.
- PROPOSED SURFACE ELEVATION

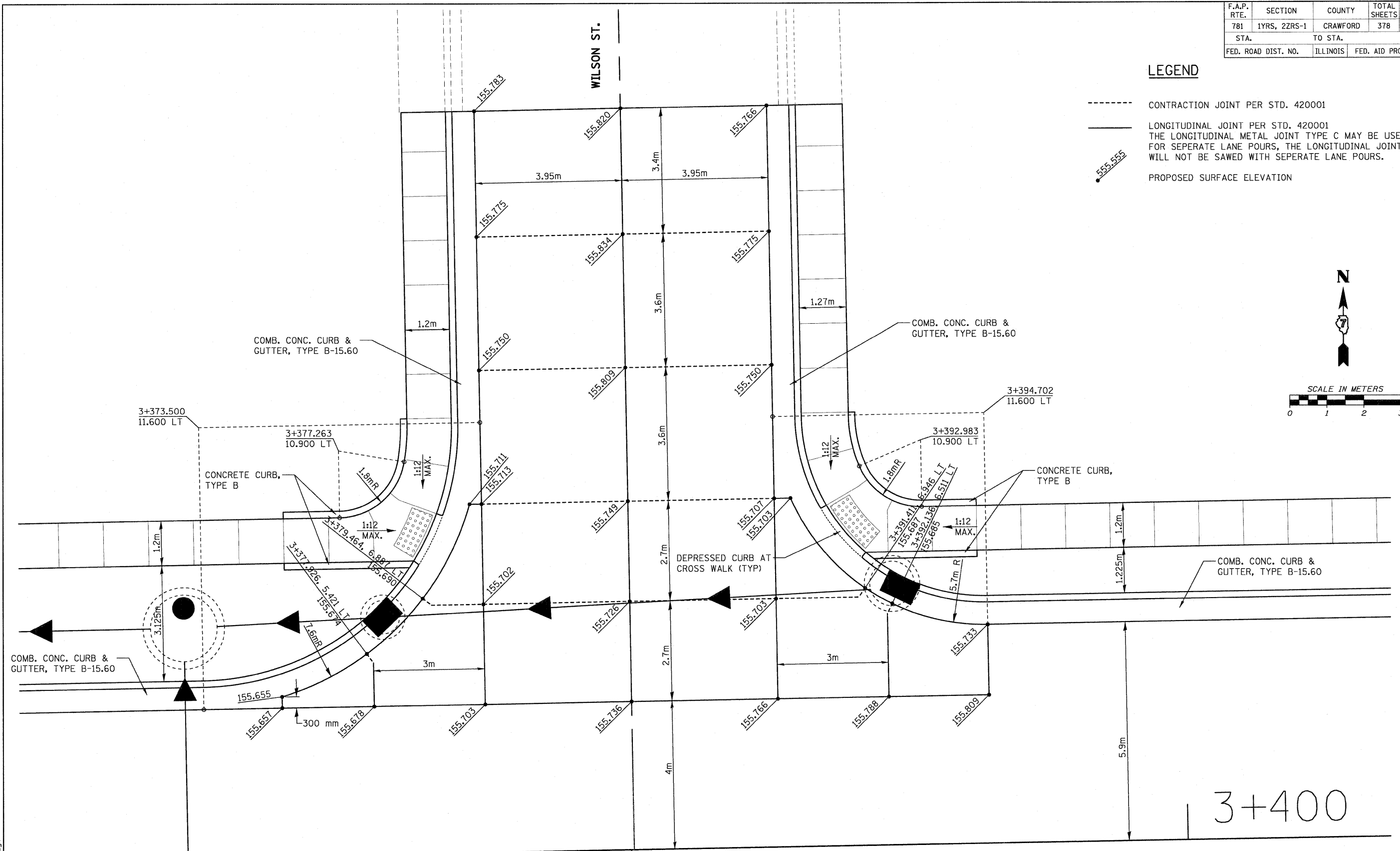
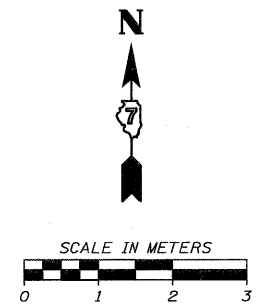

☐ STA. 10+000 WILSON ST. =
☐ STA. 3+385.050 IL. RTE. 33

3+400

PLOT DATE = 3/20/2008
FILE NAME = H:\4420\70157_int.WilsonN.dgn

REVISIONS		ILLINOIS DEPARTMENT OF TRANSPORTATION
NAME	DATE	
		INTERSECTION DETAIL WILSON ST.

SCALE AS SHOWN DRAWN BY EDW
DATE MARCH 20, 2008 CHECKED BY RGH

H. M. & G. NO. 4420

F.A.P. RTE.	SECTION	COUNTY	TOTAL SHEETS	SHEET NO.
781	1YRS, 2ZRS-1	CRAWFORD	378	158
STA.		TO STA.		
FED. ROAD DIST. NO.		ILLINOIS	FED. AID PROJECT	

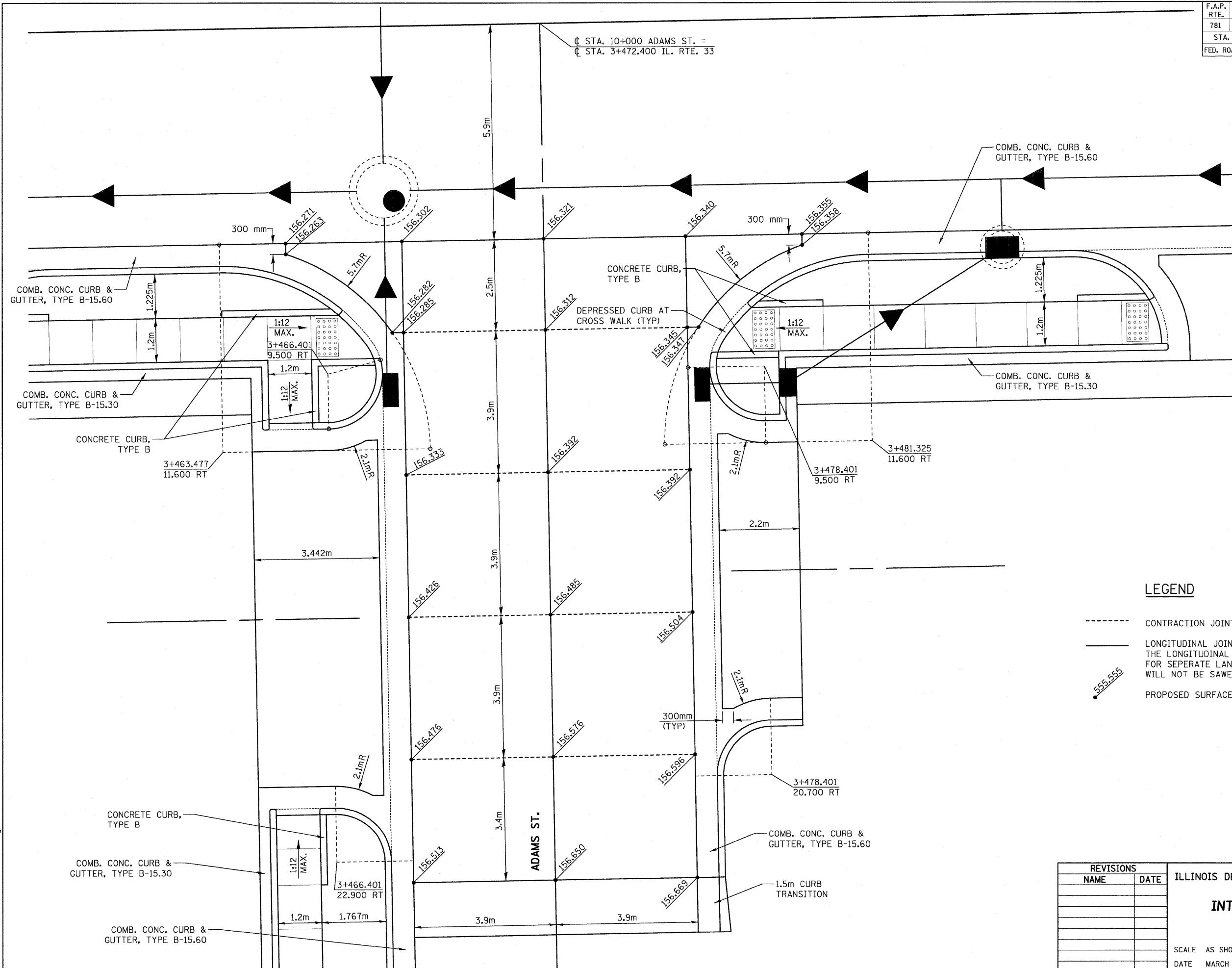

LEGEND

- CONTRACTION JOINT PER STD. 420001
- LONGITUDINAL JOINT PER STD. 420001
THE LONGITUDINAL METAL JOINT TYPE C MAY BE USED FOR SEPERATE LANE POURS, THE LONGITUDINAL JOINT WILL NOT BE SAWED WITH SEPERATE LANE POURS.
- 555.555 PROPOSED SURFACE ELEVATION

REVISIONS	
NAME	DATE

ILLINOIS DEPARTMENT OF TRANSPORTATION

**INTERSECTION DETAIL
ADAMS STREET**

SCALE AS SHOWN DRAWN BY EDW
DATE MARCH 20, 2008 CHECKED BY RGH

PLOT DATE = 3/20/2008
FILE NAME = H:\4428\70158_int_Adams.dgn

H. M. & G. NO. 4420

F.A.P. RTE.	SECTION	COUNTY	TOTAL SHEETS	SHEET NO.
781	1YRS, 2ZRS-1	CRAWFORD	378	159
STA.		TO STA.		
FED. ROAD DIST. NO.		ILLINOIS	FED. AID PROJECT	

LEGEND

- CONTRACTION JOINT PER STD. 420001
- LONGITUDINAL JOINT PER STD. 420001
THE LONGITUDINAL METAL JOINT TYPE C MAY BE USED FOR SEPERATE LANE POURS, THE LONGITUDINAL JOINT WILL NOT BE SAWED WITH SEPERATE LANE POURS.
- 555.555 PROPOSED SURFACE ELEVATION

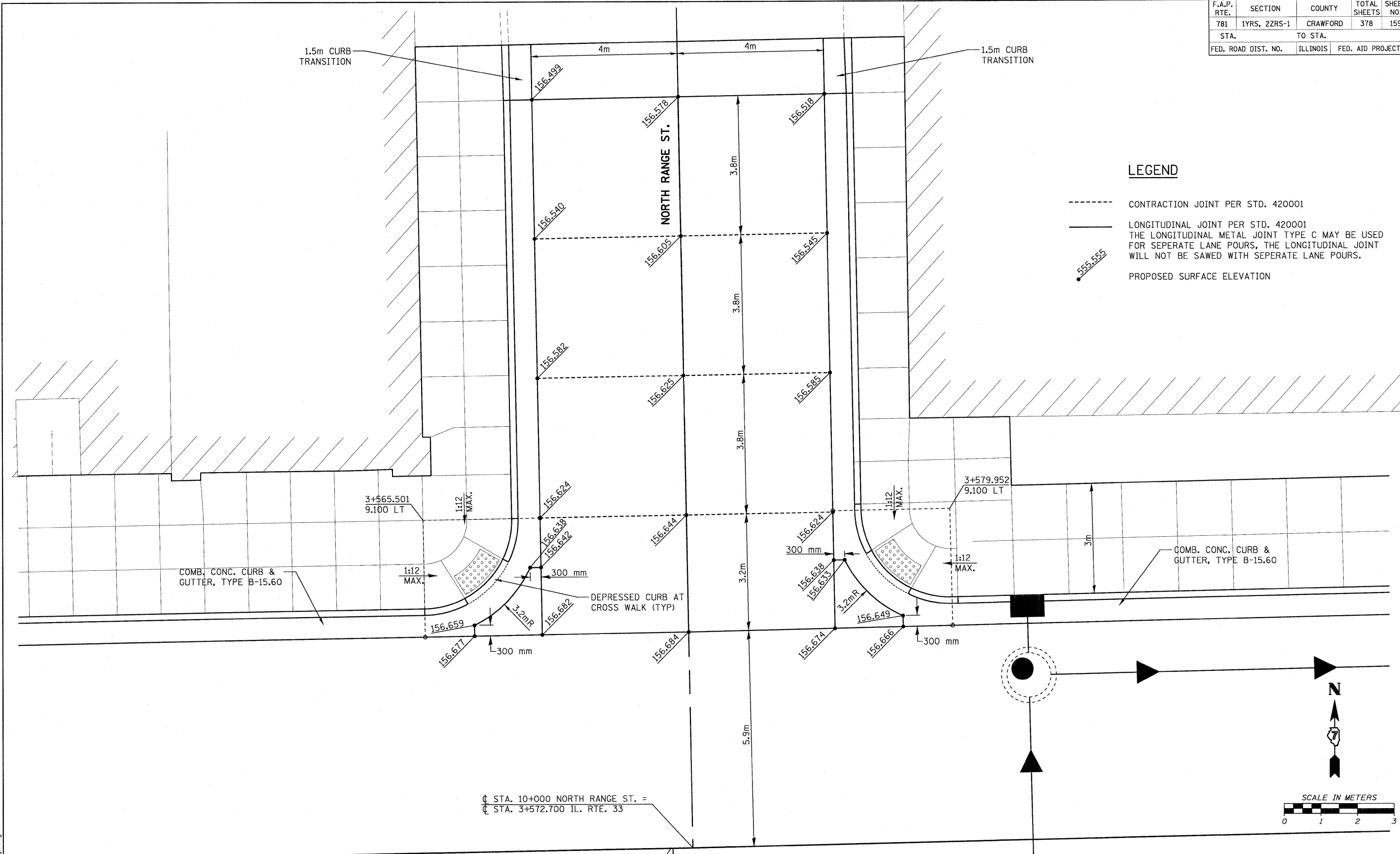

⊕ STA. 10+000 NORTH RANGE ST. =
⊕ STA. 3+572.700 IL. RTE. 33

⊕ STA. 10+000 SOUTH RANGE ST. =
⊕ STA. 3+572.100 IL. RTE. 33

REVISIONS		ILLINOIS DEPARTMENT OF TRANSPORTATION
NAME	DATE	
		<p>INTERSECTION DETAIL NORTH RANGE STREET</p> <p>SCALE AS SHOWN DRAWN BY EDW DATE MARCH 20, 2008 CHECKED BY RGH</p>

PLOT DATE = 3/20/2008
FILE NAME = H:\4420\78159_int_Rengelt.dgn

H. M. & G. NO. 4420

F.A.P. RTE.	SECTION	COUNTY	TOTAL SHEETS	SHEET NO.
781	1YRS, 2ZRS-1	CRAWFORD	378	160
STA.		TO STA.		
FED. ROAD DIST. NO.		ILLINOIS	FED. AID PROJECT	

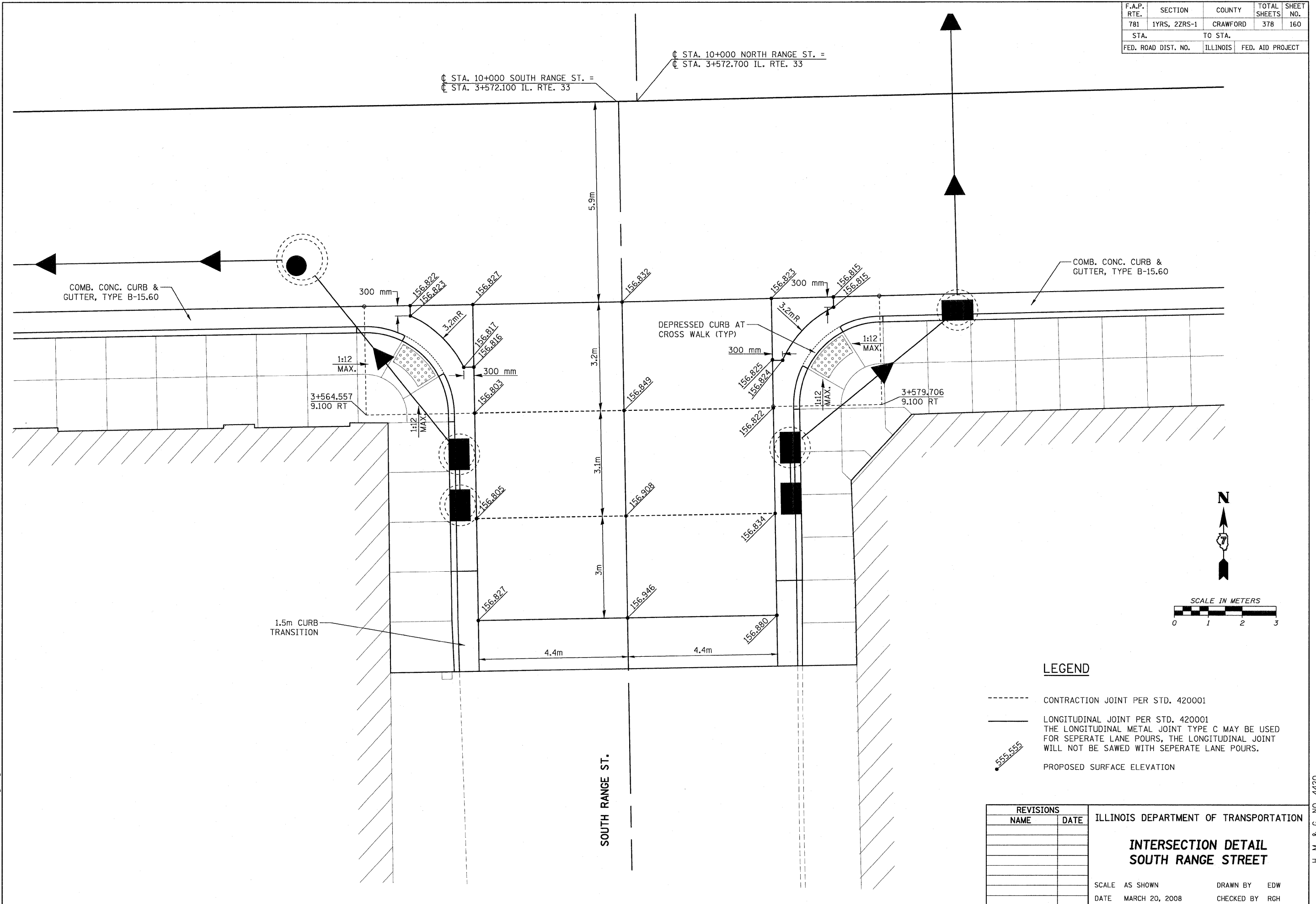

PLOT DATE = 3/20/2008
 FILE NAME = H:\4428\70160_int_RangeS.dgn

H. M. & G. NO. 4420

F.A.P. RTE.	SECTION	COUNTY	TOTAL SHEETS	SHEET NO.
781	1YRS, 2ZRS-1	CRAWFORD	378	161
STA. TO STA.		FED. ROAD DIST. NO. ILLINOIS FED. AID PROJECT		

LEGEND

- CONTRACTION JOINT PER STD. 420001
- LONGITUDINAL JOINT PER STD. 420001
THE LONGITUDINAL METAL JOINT TYPE C MAY BE USED FOR SEPERATE LANE POURS, THE LONGITUDINAL JOINT WILL NOT BE SAWED WITH SEPERATE LANE POURS.
- 555.555 PROPOSED SURFACE ELEVATION

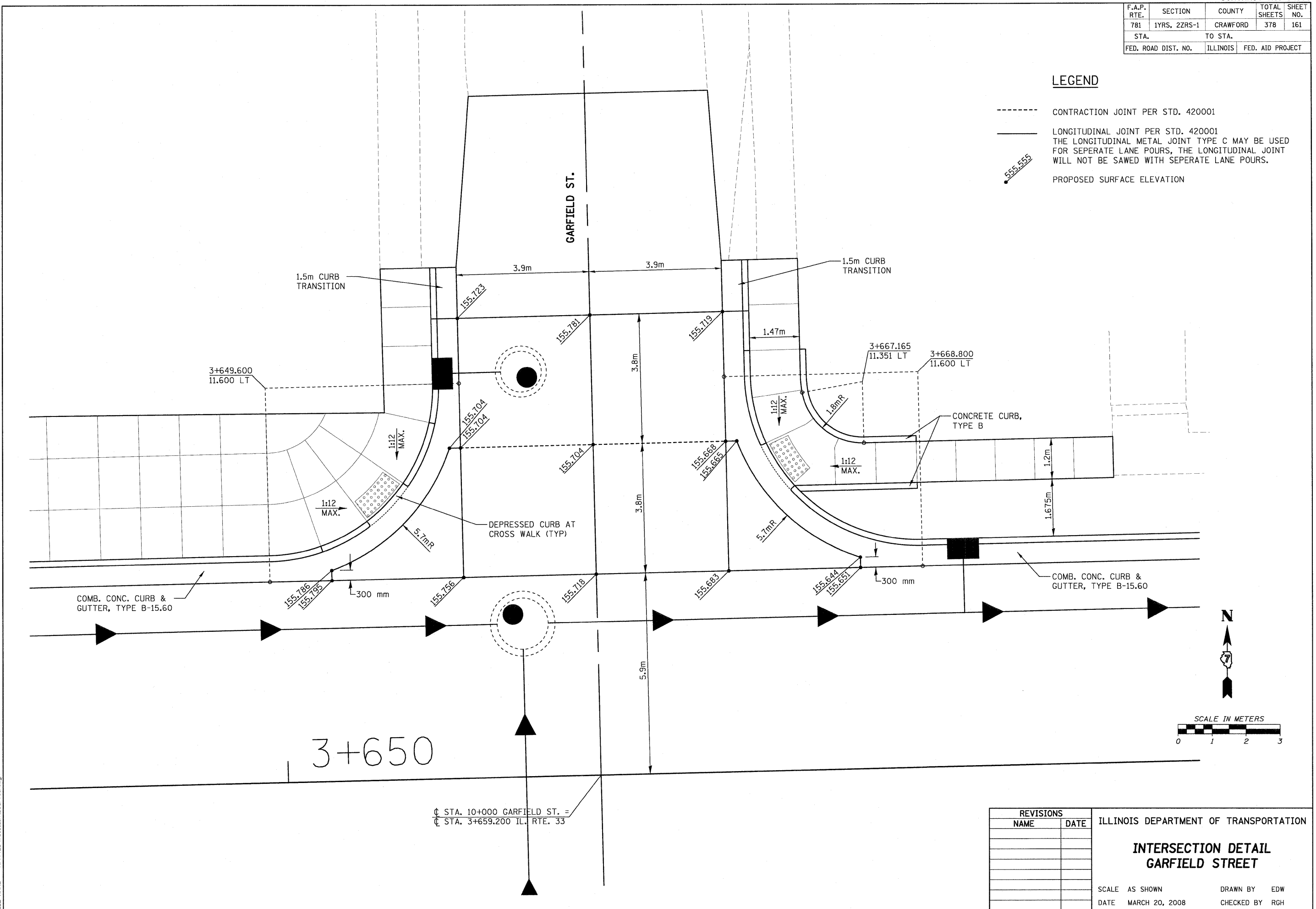

PLOT DATE = 3/20/2008
 FILE NAME = H:\4420\781B1.int-Garfield.dgn

H. M. & G. NO. 4420

REVISIONS		ILLINOIS DEPARTMENT OF TRANSPORTATION
NAME	DATE	
		INTERSECTION DETAIL GARFIELD STREET
		SCALE AS SHOWN DATE MARCH 20, 2008
		DRAWN BY EDW CHECKED BY RGH

F.A.P. RTE.	SECTION	COUNTY	TOTAL SHEETS	SHEET NO.
781	1YRS, 2ZRS-1	CRAWFORD	378	162
STA.		TO STA.		
FED. ROAD DIST. NO.		ILLINOIS	FED. AID PROJECT	

3+650

CL STA. 10+000 GARFIELD ST. =
CL STA. 3+659.200 IL. RTE. 33

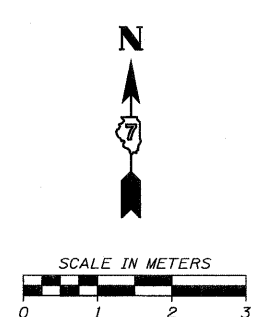
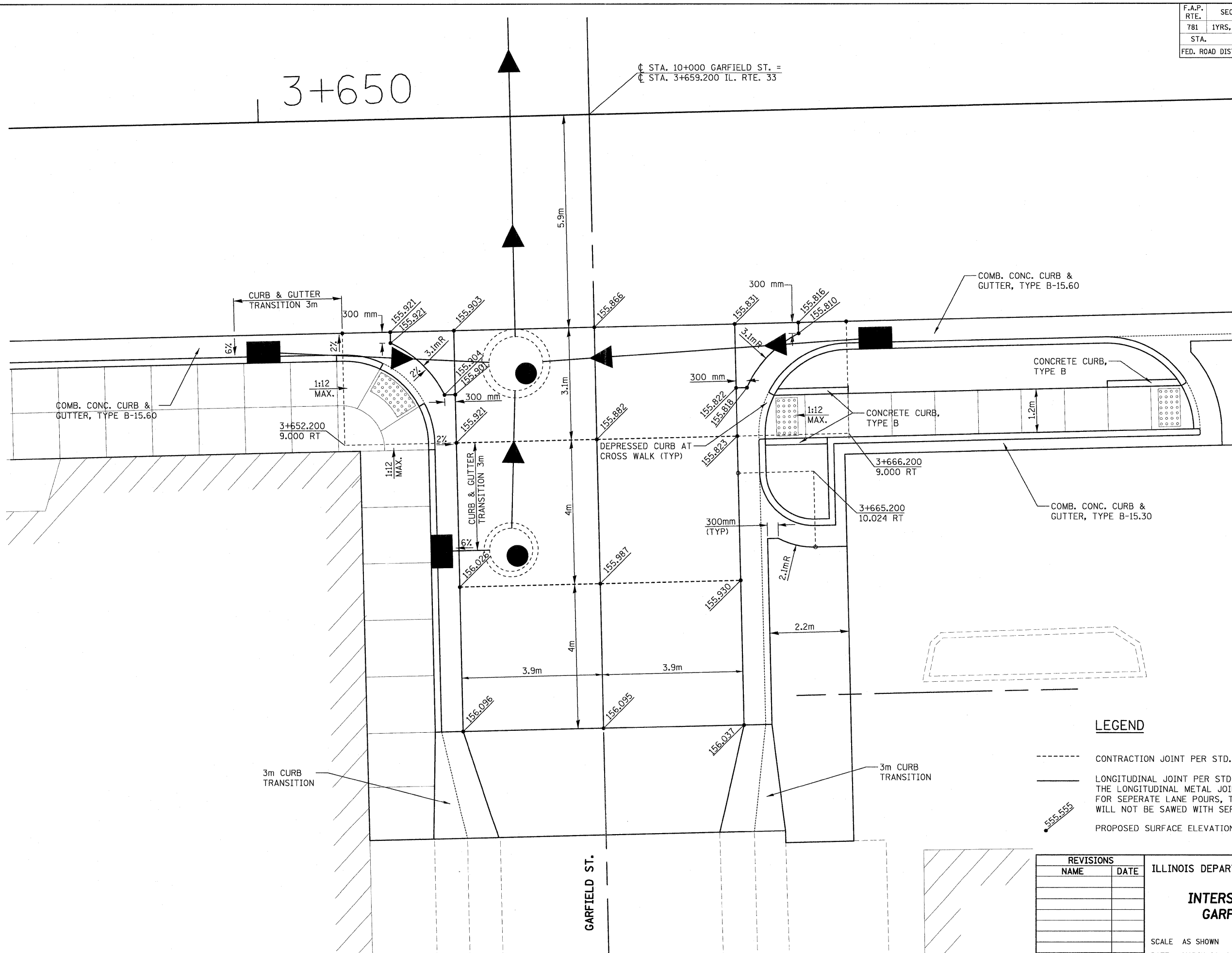

LEGEND

- CONTRACTION JOINT PER STD. 420001
- LONGITUDINAL JOINT PER STD. 420001
THE LONGITUDINAL METAL JOINT TYPE C MAY BE USED FOR SEPARATE LANE POURS, THE LONGITUDINAL JOINT WILL NOT BE SAWED WITH SEPARATE LANE POURS.
- 555.555 PROPOSED SURFACE ELEVATION

REVISIONS	
NAME	DATE

ILLINOIS DEPARTMENT OF TRANSPORTATION

**INTERSECTION DETAIL
GARFIELD STREET**

SCALE AS SHOWN DRAWN BY EDW
DATE MARCH 20, 2008 CHECKED BY RGH

PLOT DATE = 3/20/2008
FILE NAME = H:\14428\70162.int_06r11d5.dgn

H. M. & G. NO. 4420

F.A.P. RTE.	SECTION	COUNTY	TOTAL SHEETS	SHEET NO.
781	1YRS, 2ZRS-1	CRAWFORD	378	163
STA.		TO STA.		
FED. ROAD DIST. NO.		ILLINOIS	FED. AID PROJECT	

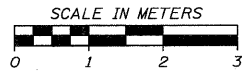

LEGEND

- CONTRACTION JOINT PER STD. 420001
- LONGITUDINAL JOINT PER STD. 420001
THE LONGITUDINAL METAL JOINT TYPE C MAY BE USED FOR SEPERATE LANE POURS, THE LONGITUDINAL JOINT WILL NOT BE SAWED WITH SEPERATE LANE POURS.
- 555.555 PROPOSED SURFACE ELEVATION

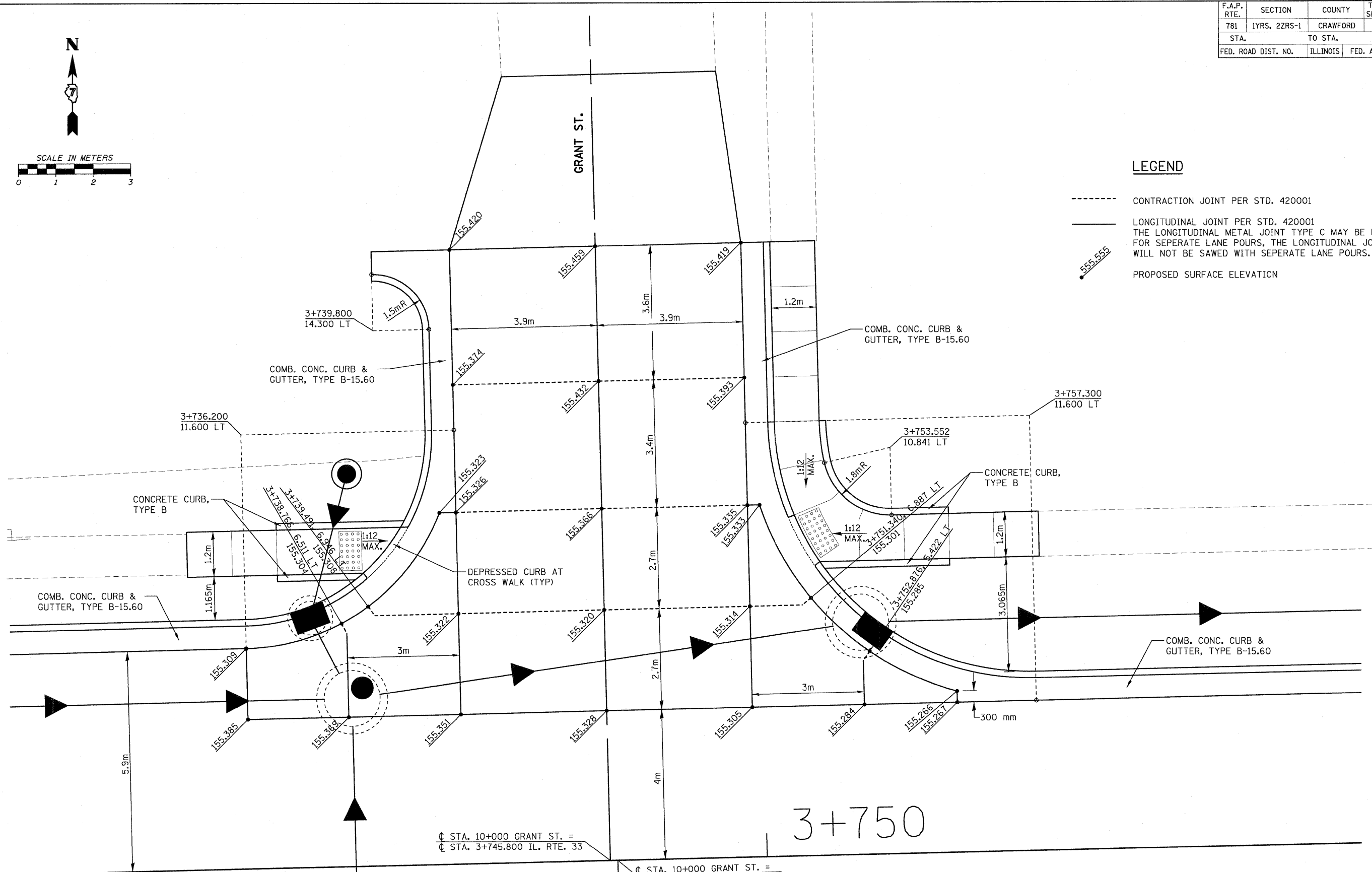

⊕ STA. 10+000 GRANT ST. =
⊕ STA. 3+745.800 IL. RTE. 33

⊕ STA. 10+000 GRANT ST. =
⊕ STA. 3+746.000 IL. RTE. 33

3+750

PLOT DATE = 3/20/2008
FILE NAME = H:\1420\70165.mt.Grant.dgn

REVISIONS		ILLINOIS DEPARTMENT OF TRANSPORTATION
NAME	DATE	
		<p align="center">INTERSECTION DETAIL GRANT STREET</p> <p>SCALE AS SHOWN DRAWN BY EDW DATE MARCH 20, 2008 CHECKED BY RGH</p>

F.A.P. RTE.	SECTION	COUNTY	TOTAL SHEETS	SHEET NO.
781	1YRS, 2ZRS-1	CRAWFORD	378	164
STA.		TO STA.		
FED. ROAD DIST. NO.		ILLINOIS	FED. AID PROJECT	

3+750

⊕ STA. 10+000 GRANT ST. =
⊕ STA. 3+745.800 IL. RTE. 33

⊕ STA. 10+000 GRANT ST. =
⊕ STA. 3+746.000 IL. RTE. 33

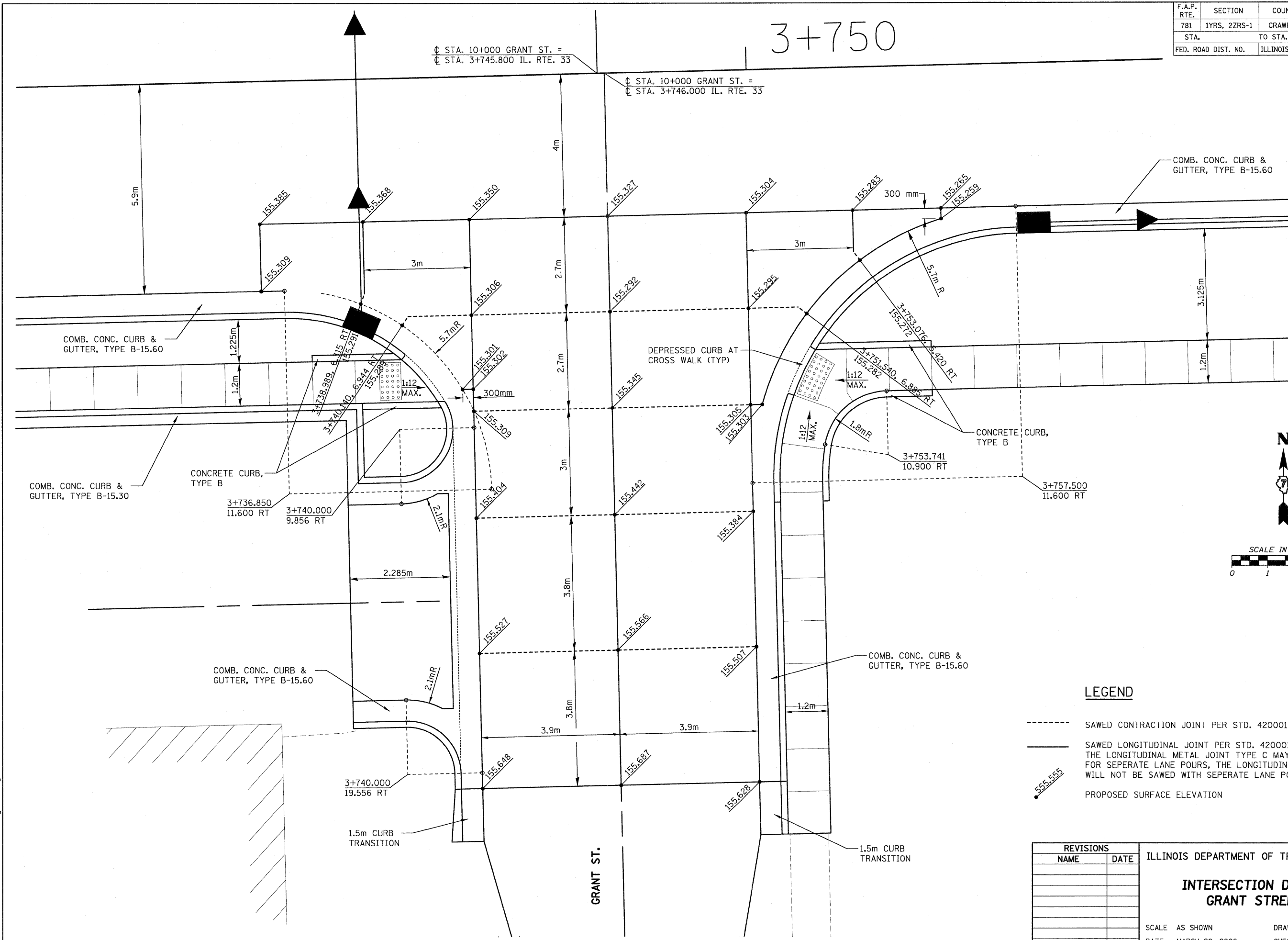

LEGEND

- SAWED CONTRACTION JOINT PER STD. 420001
- SAWED LONGITUDINAL JOINT PER STD. 420001
- THE LONGITUDINAL METAL JOINT TYPE C MAY BE USED FOR SEPARATE LANE POURS, THE LONGITUDINAL JOINT WILL NOT BE SAWED WITH SEPARATE LANE POURS.
- 555.555 PROPOSED SURFACE ELEVATION

REVISIONS	
NAME	DATE

ILLINOIS DEPARTMENT OF TRANSPORTATION

**INTERSECTION DETAIL
GRANT STREET**

SCALE AS SHOWN DRAWN BY EDW
DATE MARCH 20, 2008 CHECKED BY RGH

PLOT DATE = 3/20/2008
FILE NAME = H:\4420\781\1\33-Intersect.dgn

H. M. & G. NO. 4420

F.A.P. RTE.	SECTION	COUNTY	TOTAL SHEETS	SHEET NO.
781	1YRS, 2ZRS-1	CRAWFORD	378	165
STA.	TO STA.			
FED. ROAD DIST. NO.	ILLINOIS	FED. AID PROJECT		

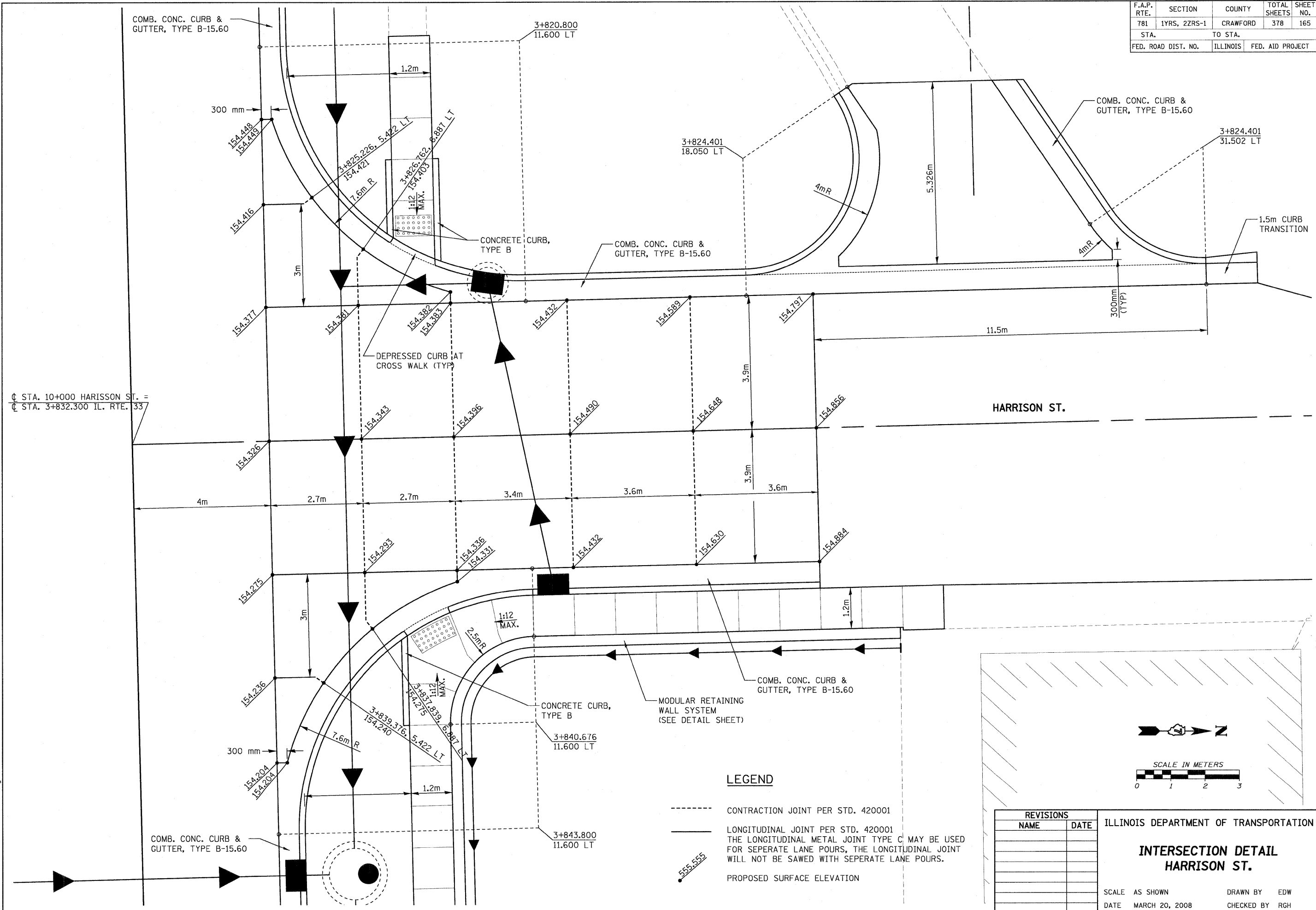

PLOT DATE = 3/20/2008
 FILE NAME = H:\4428\78165_int_HrrrnN.dgn

H. M. & C. NO. 4420

F.A.P. RTE.	SECTION	COUNTY	TOTAL SHEETS	SHEET NO.
781	1YRS, 2ZRS-1	CRAWFORD	378	166
STA.		TO STA.		
FED. ROAD DIST. NO.		ILLINOIS	FED. AID PROJECT	

LEGEND

- CONTRACTION JOINT PER STD. 420001
- LONGITUDINAL JOINT PER STD. 420001
THE LONGITUDINAL METAL JOINT TYPE C MAY BE USED FOR SEPERATE LANE POURS, THE LONGITUDINAL JOINT WILL NOT BE SAWED WITH SEPERATE LANE POURS.
- 555.555 PROPOSED SURFACE ELEVATION

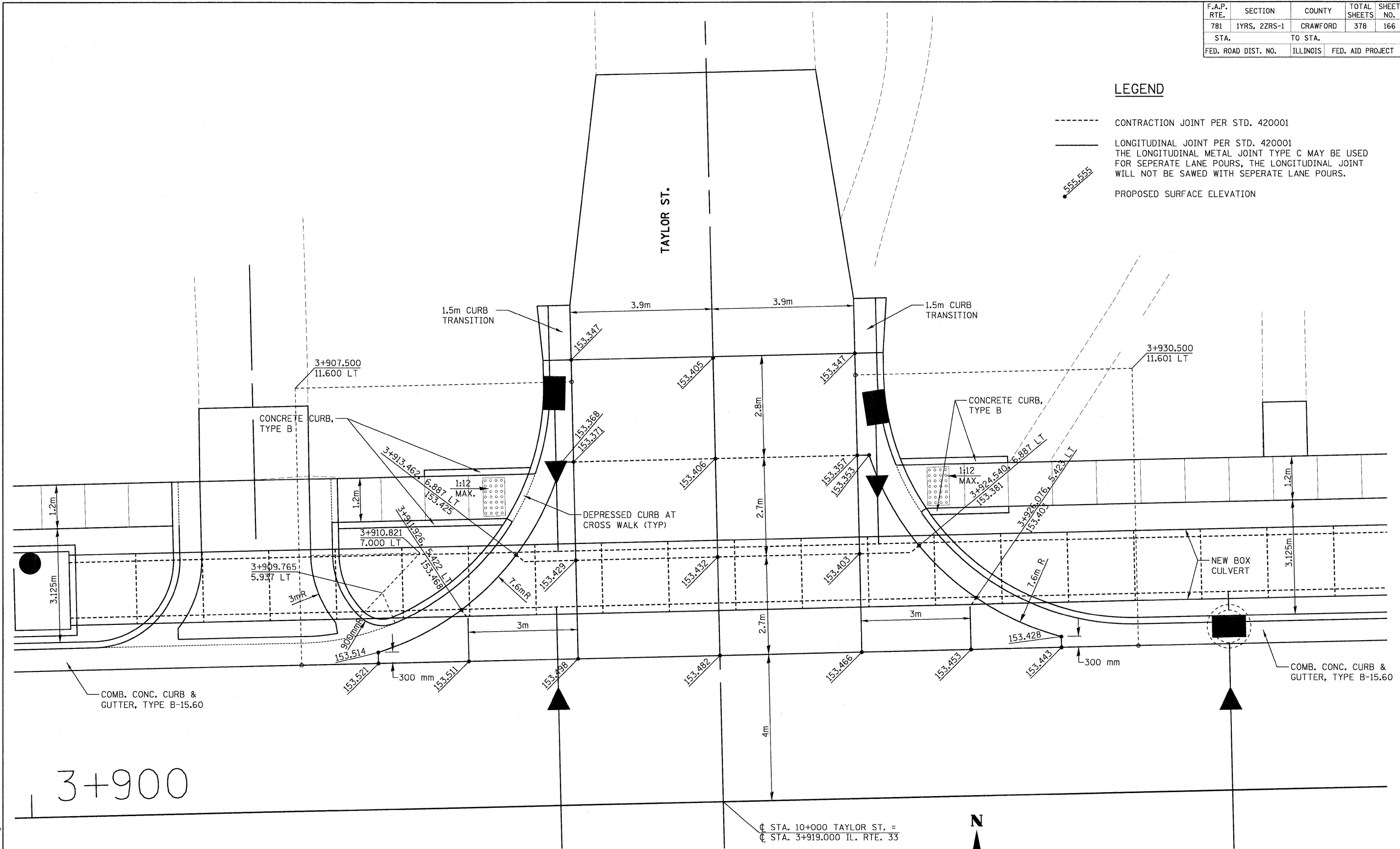

3+900

⊕ STA. 10+000 TAYLOR ST. =
⊕ STA. 3+919.000 IL. RTE. 33

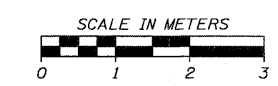

REVISIONS	
NAME	DATE

ILLINOIS DEPARTMENT OF TRANSPORTATION

**INTERSECTION DETAIL
TAYLOR ST.**

SCALE AS SHOWN DRAWN BY EDW
DATE MARCH 20, 2008 CHECKED BY RGH

PLOT DATE = 3/20/2008
FILE NAME = H:\4420\781B6.int-Taylor\tdgn

H. M. & C. NO. 4420

F.A.P. RTE.	SECTION	COUNTY	TOTAL SHEETS	SHEET NO.
781	1YRS, 2ZRS-1	CRAWFORD	378	168
STA.		TO STA.		
FED. ROAD DIST. NO.	ILLINOIS	FED. AID PROJECT		

4+150

⊙ STA. 10+000 ROOSEVELT ST. =
⊙ STA. 4+155.800 IL. RTE. 33

COMB. CONC. CURB & GUTTER, TYPE B-15.60

COMB. CONC. CURB & GUTTER, TYPE B-15.60

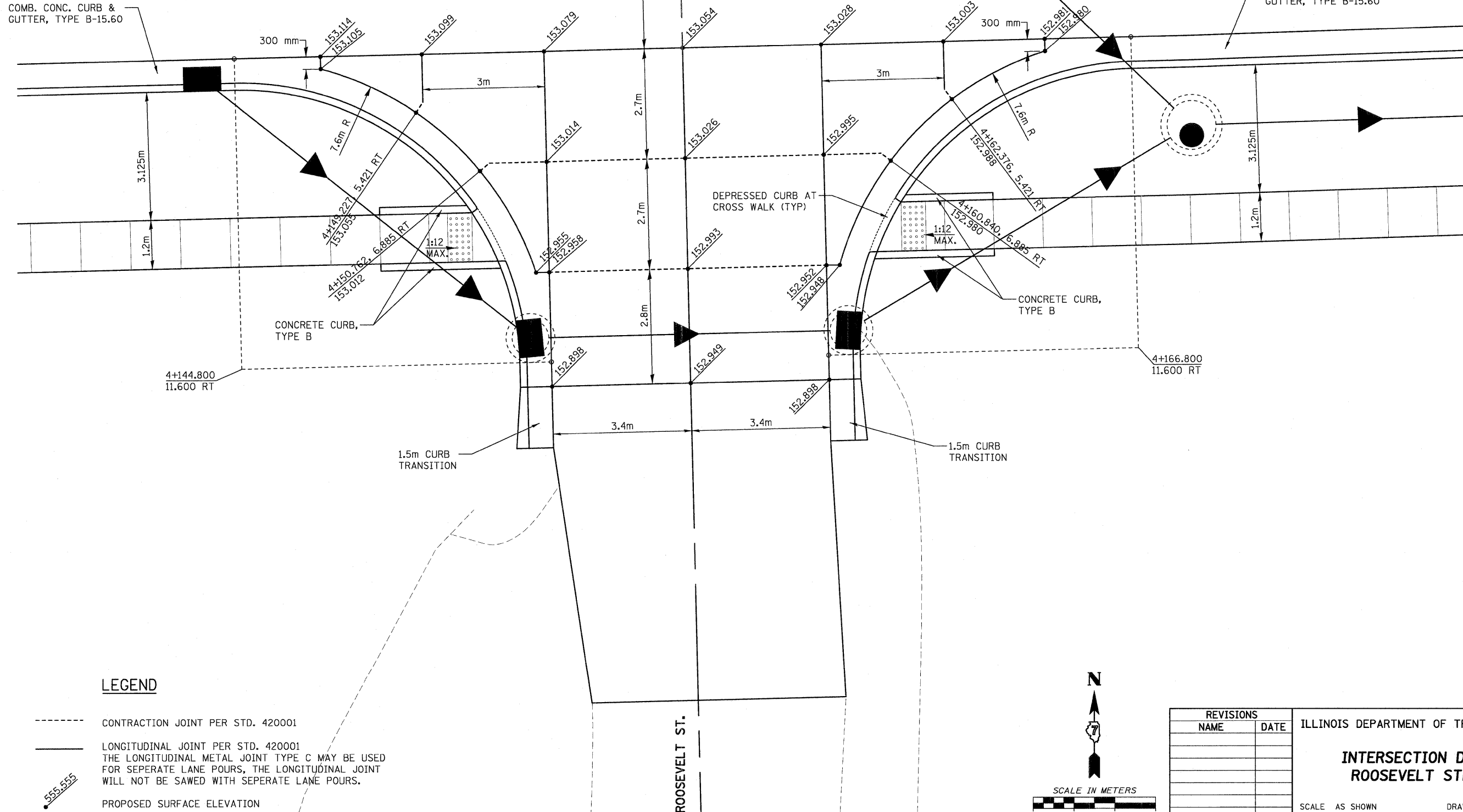

LEGEND

- CONTRACTION JOINT PER STD. 420001
- LONGITUDINAL JOINT PER STD. 420001
THE LONGITUDINAL METAL JOINT TYPE C MAY BE USED FOR SEPARATE LANE POURS, THE LONGITUDINAL JOINT WILL NOT BE SAWED WITH SEPARATE LANE POURS.
- PROPOSED SURFACE ELEVATION

PLOT DATE = 3/20/2008
FILE NAME = H:\4428\78168B_int.Road\15.dgn

REVISIONS	
NAME	DATE

ILLINOIS DEPARTMENT OF TRANSPORTATION

**INTERSECTION DETAIL
ROOSEVELT STREET**

SCALE AS SHOWN DRAWN BY EDW
DATE MARCH 20, 2008 CHECKED BY RGH

H. M. & G. NO. 4420

F.A.P. RTE.	SECTION	COUNTY	TOTAL SHEETS	SHEET NO.
781	1YRS, 2ZRS-1	CRAWFORD	378	169
STA.		TO STA.		
FED. ROAD DIST. NO.		ILLINOIS	FED. AID PROJECT	

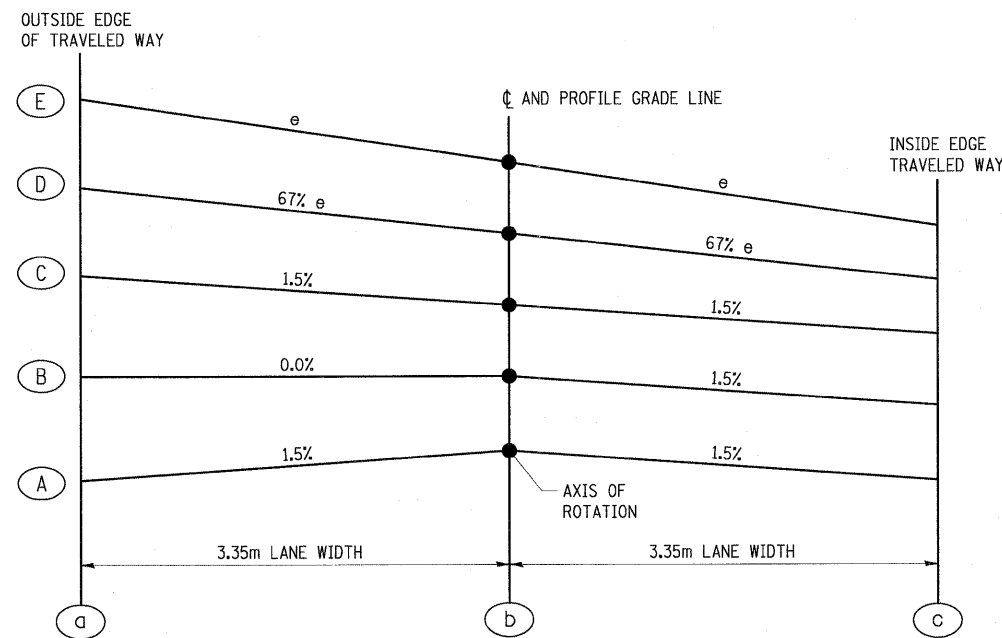
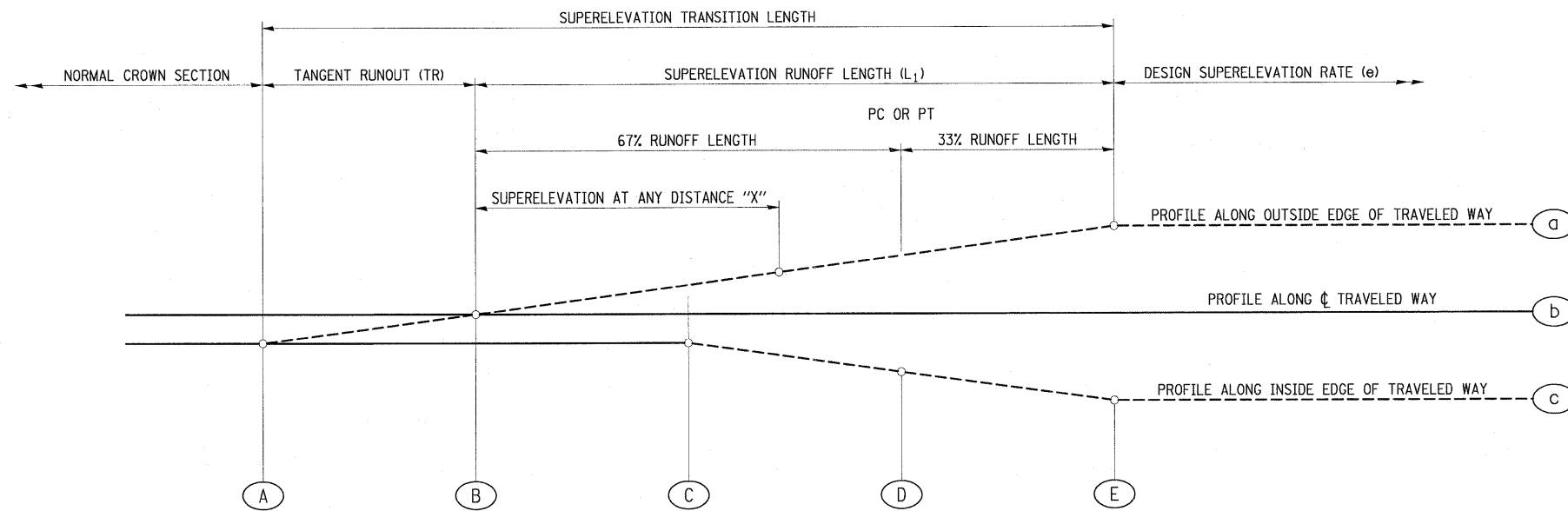

NOTES

- REFER TO THE TYPICAL SECTIONS, PLAN & PROFILE SHEETS AND THE SUPERELEVATION DATA TABLES ON THE FOLLOWING SHEET FOR DETAILED INFORMATION AT EACH CURVE.
- TO COMPUTE THE SUPERELEVATION AT ANY DISTANCE "X" FROM POINT B, USE THE FOLLOWING:

$$\text{SUPERELEVATION AT ANY DISTANCE "X"} = \frac{(3.35e/L_1) \times \text{DISTANCE "X"}}{36}$$

TYPICAL SUPERELEVATION TRANSITION DETAILS

REVISIONS		ILLINOIS DEPARTMENT OF TRANSPORTATION
NAME	DATE	
		<p>TYPICAL SUPERELEVATION TRANSITION DETAIL</p> <p>SCALE NO SCALE DRAWN BY KOJ</p> <p>DATE MARCH 20, 2008 CHECKED BY RGH</p>

PLOT DATE = 3/20/2008
FILE NAME = H:\4420\781\69_detailed.dgn

F.A.P. RTE.	SECTION	COUNTY	TOTAL SHEETS	SHEET NO.
781	1YRS, 2ZRS-1	CRAWFORD	378	170
STA.		TO STA.		
FED. ROAD DIST. NO.		ILLINOIS	FED. AID PROJECT	

CURVE P2 TRANSITION DETAILS

R = 307.912 NC = -1.5% LANE WIDTH = 3.35m

CURVE = LEFT SE = 6.0%

ROUNDED	1/3	2/3	CURVE STATIONS
L1 43	14	29	PC 1+887.948
TR 11	---	---	PT 2+113.592

	STATION	SUPERELEVATION	
		LEFT	RIGHT
A	1+847.948	-1.50%	-1.50%
B	1+858.948	-1.50%	0.0%
C	1+869.948	-1.50%	1.50%
D	1+887.948	-4.03%	4.03%
E	1+901.948	-6.0%	6.0%
E	2+099.592	-6.0%	6.0%
D	2+113.592	-4.03%	4.03%
C	2+131.592	-1.50%	1.50%
B	2+142.592	-1.50%	0.0%
A	2+153.592	-1.50%	-1.50%

CURVE P5 TRANSITION DETAILS

R = 577.756 NC = -2.0% LANE WIDTH = 3.35m

CURVE = RIGHT SE = 2.8%

ROUNDED	1/3	2/3	CURVE STATIONS
L1 20	7	13	PC 4+374.882
TR 14	---	---	PT 4+428.404

	STATION	SUPERELEVATION	
		LEFT	RIGHT
A	4+347.882	-2.00%	-2.00%
B	4+361.882	-2.00%	0.0%
C	4+375.882	-2.00%	2.00%
D	4+374.882	-1.87%	1.87%
E	4+381.882	-2.8%	2.8%
E	4+421.404	-2.8%	2.8%
D	4+428.404	-1.87%	1.87%
C	4+427.404	-2.00%	2.00%
B	4+441.404	-2.00%	0.0%
A	4+455.404	-2.00%	-2.00%

CURVE P8 TRANSITION DETAILS

R = 581.672 NC = -1.5% LANE WIDTH = 3.35m

CURVE = RIGHT SE = 5.2%

ROUNDED	1/3	2/3	CURVE STATIONS
L1 37	12	25	PC 5+944.938
TR 11	---	---	PT 6+120.199

	STATION	SUPERELEVATION	
		LEFT	RIGHT
A	5+908.938	-1.50%	-1.50%
B	5+919.938	-1.50%	0.0%
C	5+930.938	-1.50%	1.50%
D	5+944.938	-3.49%	3.49%
E	5+956.938	-5.2%	5.2%
E	6+108.199	-5.2%	5.2%
D	6+120.199	-3.49%	3.49%
C	6+134.199	-1.50%	1.50%
B	6+145.199	-1.50%	0.0%
A	6+156.199	-1.50%	-1.50%

CURVE P9 TRANSITION DETAILS

R = 651.393 NC = -1.5% LANE WIDTH = 3.35m

CURVE = RIGHT SE = 4.4%

ROUNDED	1/3	2/3	CURVE STATIONS
L1 31	10	21	PC 6+380.742
TR 11	---	---	PT 6+565.330

	STATION	SUPERELEVATION	
		LEFT	RIGHT
A	6+348.742	-1.50%	-1.50%
B	6+359.742	-1.50%	0.0%
C	6+370.742	-1.50%	1.50%
D	6+380.742	-2.95%	2.95%
E	6+390.742	-4.4%	4.4%
E	6+555.330	-4.4%	4.4%
D	6+565.330	-2.95%	2.95%
C	6+575.330	-1.50%	1.50%
B	6+586.330	-1.50%	0.0%
A	6+597.330	-1.50%	-1.50%

CURVE P10 TRANSITION DETAILS

R = 802.264 NC = -1.5% LANE WIDTH = 3.35m

CURVE = LEFT SE = 4.8%

ROUNDED	1/3	2/3	CURVE STATIONS
L1 34	11	23	PC 6+986.819
TR 11	---	---	PT 7+118.219

	STATION	SUPERELEVATION	
		LEFT	RIGHT
A	6+952.819	-1.50%	-1.50%
B	6+963.819	-1.50%	0.0%
C	6+974.819	-1.50%	1.50%
D	6+986.819	-3.22%	3.22%
E	6+997.819	-4.8%	4.8%
E	7+107.219	-4.8%	4.8%
D	7+118.219	-3.22%	3.22%
C	7+130.219	-1.50%	1.50%
B	7+141.219	-1.50%	0.0%
A	7+152.219	-1.50%	-1.50%

CURVE P11 TRANSITION DETAILS

R = 581.332 NC = -1.5% LANE WIDTH = 3.35m

CURVE = LEFT SE = 5.0%

ROUNDED	1/3	2/3	CURVE STATIONS
L1 36	12	24	PC 7+373.093
TR 11	---	---	PT 7+466.210

	STATION	SUPERELEVATION	
		LEFT	RIGHT
A	7+338.093	-1.50%	-1.50%
B	7+349.093	-1.50%	0.0%
C	7+360.093	-1.50%	1.50%
D	7+373.093	-3.32%	3.32%
E	7+385.093	-5.0%	5.0%
E	7+454.210	-5.0%	5.0%
D	7+466.210	-3.32%	3.32%
C	7+479.210	-1.50%	1.50%
B	7+490.210	-1.50%	0.0%
A	7+501.210	-1.50%	-1.50%

CURVE P16 TRANSITION DETAILS

R = 871.357 NC = -1.5% LANE WIDTH = 3.35m

CURVE = LEFT SE = 4.5%

ROUNDED	1/3	2/3	CURVE STATIONS
L1 32	11	21	PC 11+902.118
TR 11	---	---	PT 12+110.906

	STATION	SUPERELEVATION	
		LEFT	RIGHT
A	11+870.118	-1.50%	-1.50%
B	11+881.118	-1.50%	0.0%
C	11+892.118	-1.50%	1.50%
D	11+902.118	-2.93%	2.93%
E	11+913.118	-4.5%	4.5%
E	12+099.906	-4.5%	4.5%
D	12+110.906	-2.93%	2.93%
C	12+120.906	-1.50%	1.50%
B	12+131.906	-1.50%	0.0%
A	12+142.906	-1.50%	-1.50%

CURVE P17 TRANSITION DETAILS

R = 867.140 NC = -1.5% LANE WIDTH = 3.35m

CURVE = RIGHT SE = 4.6%

ROUNDED	1/3	2/3	CURVE STATIONS
L1 33	11	22	PC 12+324.152
TR 11	---	---	PT 12+554.276

	STATION	SUPERELEVATION	
		LEFT	RIGHT
A	12+291.152	-1.50%	-1.50%
B	12+302.152	-1.50%	0.0%
C	12+313.152	-1.50%	1.50%
D	12+324.152	-3.05%	3.05%
E	12+335.152	-4.6%	4.6%
E	12+543.276	-4.6%	4.6%
D	12+554.276	-3.05%	3.05%
C	12+565.276	-1.50%	1.50%
B	12+576.276	-1.50%	0.0%
A	12+587.276	-1.50%	-1.50%

PLOT DATE = 3/20/2008
FILE NAME = H:\4428\781689.dgn

REVISIONS	
NAME	DATE

ILLINOIS DEPARTMENT OF TRANSPORTATION

SUPERELEVATION TRANSITION DATA TABLES

SCALE NO SCALE DRAWN BY KOJ
DATE MARCH 20, 2008 CHECKED BY RGH

F.A.P. RTE.	SECTION	COUNTY	TOTAL SHEETS	SHEET NO.
781	1YRS, 2ZRS-1	CRAWFORD	378	171
STA.		TO STA.		
FED. ROAD DIST. NO.		ILLINOIS	FED. AID PROJECT	

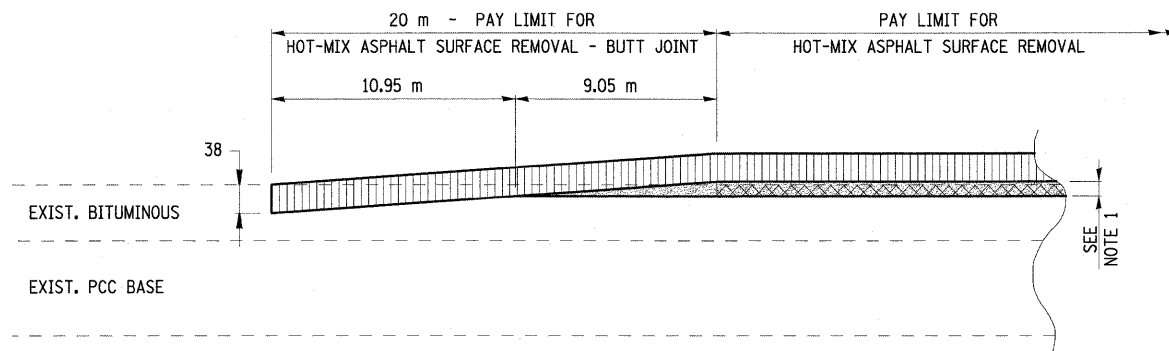

- HOT-MIX ASPHALT SURFACE REMOVAL
- HOT-MIX ASPHALT SURFACE COURSE
- HOT-MIX ASPHALT BINDER COURSE OR LEVEL BINDER

BUTT JOINT DETAIL

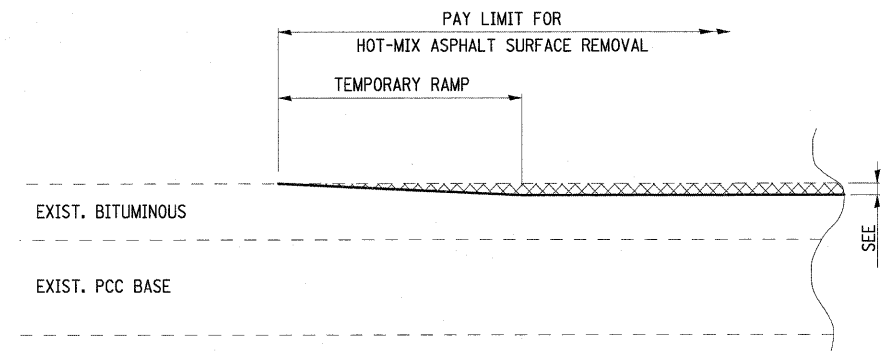

- HOT-MIX ASPHALT SURFACE REMOVAL

MILLED TEMPORARY RAMP

NOTES

- REFER TO THE HOT-MIX ASPHALT SURFACE REMOVAL DETAILS BELOW AND THE HOT-MIX ASPHALT SURFACE REMOVAL SCHEDULE FOR MILLING THICKNESSES.
- BUTT JOINTS AND TEMPORARY RAMPS SHALL BE PLACED AS SHOWN ON THE PLANS OR AS DIRECTED BY THE ENGINEER.
- BUTT JOINTS SHALL BE CONSTRUCTED IMMEDIATELY PRIOR TO THE PLACING OF THE PROPOSED HOT-MIX ASPHALT COURSES.
- TAPER THE TEMPORARY RAMP AT A RATE OF 900mm (3') PER 25mm (1") OF MILLING THICKNESS.
- TEMPORARY RAMPS SHALL BE CONSTRUCTED AT ALL BUTT JOINT LOCATIONS. AT ALL OTHER PAVEMENT TRANSITIONS THE MILLED TEMPORARY RAMP SHALL BE USED. THE INSTALLATION AND SUBSEQUENT REMOVAL OF THE TEMPORARY RAMP WILL BE PAID FOR AT THE CONTRACT UNIT PRICE PER SQUARE METER FOR TEMPORARY RAMP. MILLED TEMPORARY RAMPS WILL NOT BE PAID FOR SEPARATELY, BUT SHALL BE INCLUDED IN THE COST OF HOT-MIX ASPHALT SURFACE REMOVAL.

NOTES

- REFER TO THE HOT-MIX ASPHALT SURFACE REMOVAL SCHEDULE FOR MILLING THICKNESSES AT ϕ AND LOCATIONS WHERE EACH OCCURS.
- MILLING SHALL BE DONE AT THE NOMINAL THICKNESS CALLED FOR AT ϕ ACROSS THE SECTION.
- MILLING TO THE BOTTOM OF WHEEL RUTS SHALL NOT BE NECESSARY UNLESS REQUIRED TO OBTAIN SLOPE OR THE DESIGN DEPTH AT CENTERLINE.
- NOMINAL MILLING AREAS SHALL BE PAID FOR UNDER THE FOLLOWING:
 - M4400715 - HOT-MIX ASPHALT SURFACE REMOVAL, 15mm
 - M4400725 - HOT-MIX ASPHALT SURFACE REMOVAL, 25mm
 - M4400740 - HOT-MIX ASPHALT SURFACE REMOVAL, 40mm

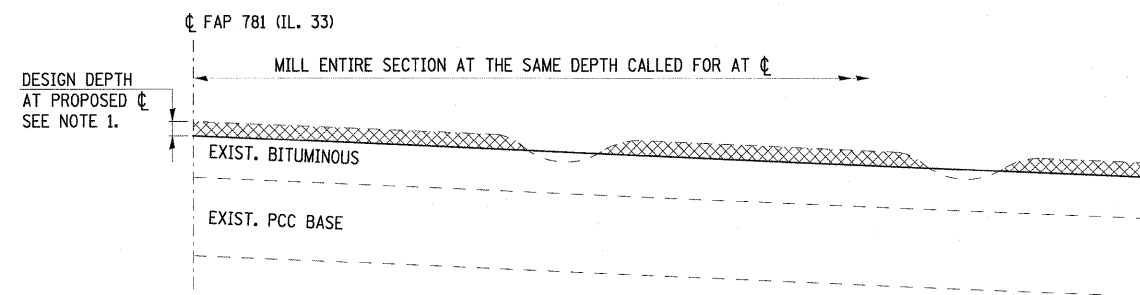

HOT-MIX ASPHALT SURFACE REMOVAL DETAIL (NOMINAL DEPTH)

NOTES

- REFER TO THE HOT-MIX ASPHALT SURFACE REMOVAL SCHEDULE FOR MILLING THICKNESSES AT ϕ AND LOCATIONS WHERE EACH OCCURS.
- MILLING SHALL BE DONE TO ATTAIN THE DESIRED DESIGN CROSSLOPE ACROSS THE SECTION.
- MILLING TO THE BOTTOM OF WHEEL RUTS SHALL NOT BE NECESSARY UNLESS REQUIRED TO OBTAIN SLOPE OR THE DESIGN DEPTH AT CENTERLINE.
- VARIABLE MILLING AREAS SHALL BE PAID FOR UNDER THE FOLLOWING:
 - M4400950 - HOT-MIX ASPHALT SURFACE REMOVAL, VARIABLE DEPTH

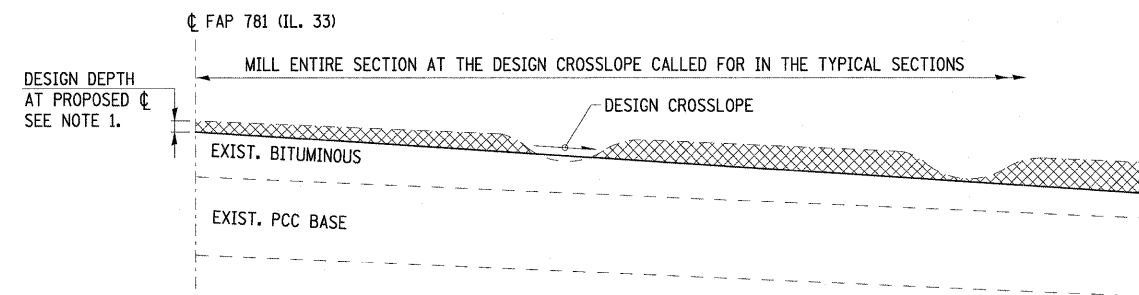

HOT-MIX ASPHALT SURFACE REMOVAL DETAIL (VARIABLE DEPTH)

ALL DIMENSIONS ARE IN MILLIMETERS UNLESS OTHERWISE SHOWN.

REVISIONS	
NAME	DATE

ILLINOIS DEPARTMENT OF TRANSPORTATION

BUTT JOINT, TAPER AND ASPHALT MILLING DETAILS

SCALE NO SCALE DRAWN BY KOJ
DATE APRIL 18, 2008 CHECKED BY RGH

PLOT DATE = 4/18/2008 FILE NAME = HV428V70169.dwg

H. M. & G. NO. 4420

F.A.P. RTE.	SECTION	COUNTY	TOTAL SHEETS	SHEET NO.
781	1YRS, 2ZRS-1	CRAWFORD	378	172
STA.		TO STA.		
FED. ROAD DIST. NO.	ILLINOIS	FED. AID PROJECT		

NOTES

1. CONCRETE STEPS ARE TO BE PROVIDED AT LOCATIONS SHOWN ON THE PLANS OR AS DESIGNATED BY THE ENGINEER WHERE THE ELEVATION DIFFERENCE BETWEEN THE BACK OF PROPOSED SIDEWALK AND PRIVATE WALK IS GREATER THAN 125 (5") IN 1.5m (5').
2. CONCRETE STEPS SHALL BE 1.2m (4') WIDE.
3. THE NUMBER OF CONCRETE STEPS SHALL SUIT THE INDIVIDUAL CONDITIONS, WITH TREAD AND RISER DIMENSIONS TO SUIT THE GRADE DIFFERENCE.
4. STEP RISER HEIGHTS SHALL BE A MINIMUM OF 125 (5") AND A MAXIMUM OF 178 (7") AND UNIFORM PER EACH SET OF STEPS. STEP TREAD WIDTHS SHALL BE A MINIMUM OF 279 (11") AND A MAXIMUM OF 300 (12") AND UNIFORM PER EACH SET OF STEPS.
5. THE COST OF THE CONCRETE STEPS SHALL BE PAID FOR AT THE CONTRACT UNIT PRICE PER CUBIC METER FOR CLASS MS CONCRETE. AN ESTIMATED QUANTITY IS PROVIDED IN THE SUMMARY OF QUANTITY SHEETS, BUT ACTUAL FIELD CONDITIONS MAY VARY, THUS INCREASING OR REDUCING THE QUANTITY PROVIDED.
6. THE REINFORCEMENT BARS AND CRUSHED AGGREGATE LEVELING PAD MATERIAL WILL NOT BE PAID FOR SEPARATELY. THE COST FOR THESE ITEMS SHALL BE INCLUDED IN THE COST OF CLASS MS CONCRETE.
7. THE REMOVAL OF ANY EXISTING STEPS AND/OR PRIVATE WALK BEHIND THE RIGHT-OF-WAY LINE SHALL BE PAID FOR AT THE CONTRACT UNIT PRICE PER SQUARE METER FOR SIDEWALK REMOVAL.

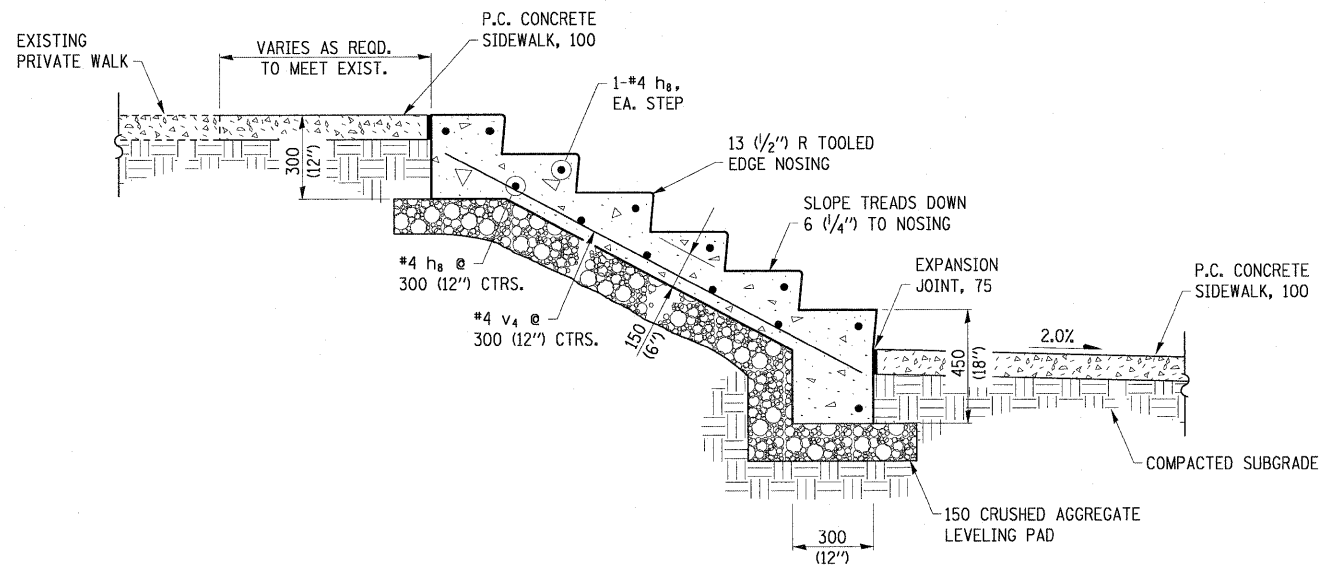

CONCRETE STEPS DETAIL

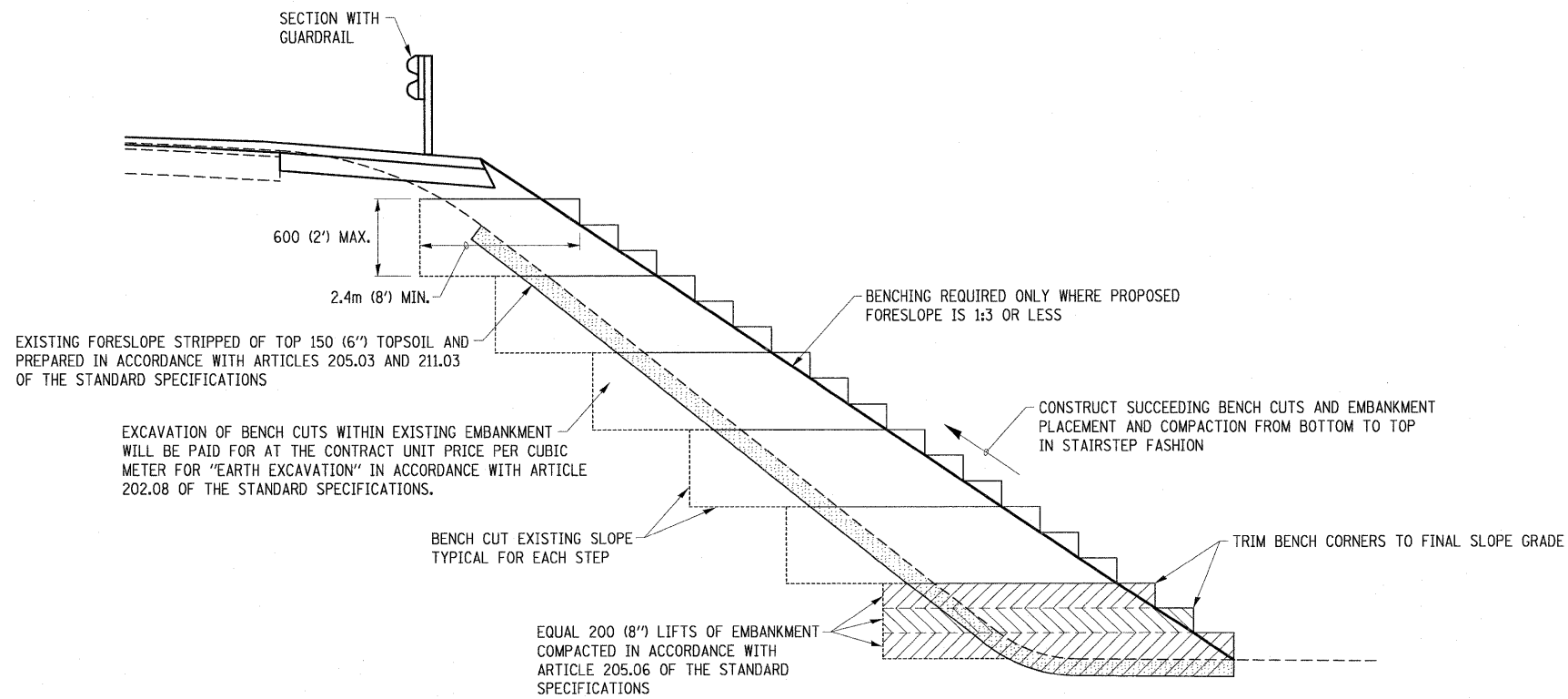

TYPICAL BENCHING DETAIL FOR EMBANKMENTS

REVISIONS		ILLINOIS DEPARTMENT OF TRANSPORTATION
NAME	DATE	
		CONCRETE STEPS AND EMBANKMENT BENCHING DETAILS SCALE NO SCALE DRAWN BY KOJ DATE MARCH 20, 2008 CHECKED BY RGH

PLOT DATE = 3/20/2008
 FILE NAME = HV442070103_detail1.dgn

H. M. & C. NO. 4420

F.A.P. RTE.	SECTION	COUNTY	TOTAL SHEETS	SHEET NO.
781	1YRS, 2ZRS-1	CRAWFORD	378	173
STA.		TO STA.		
FED. ROAD DIST. NO.		ILLINOIS	FED. AID PROJECT	

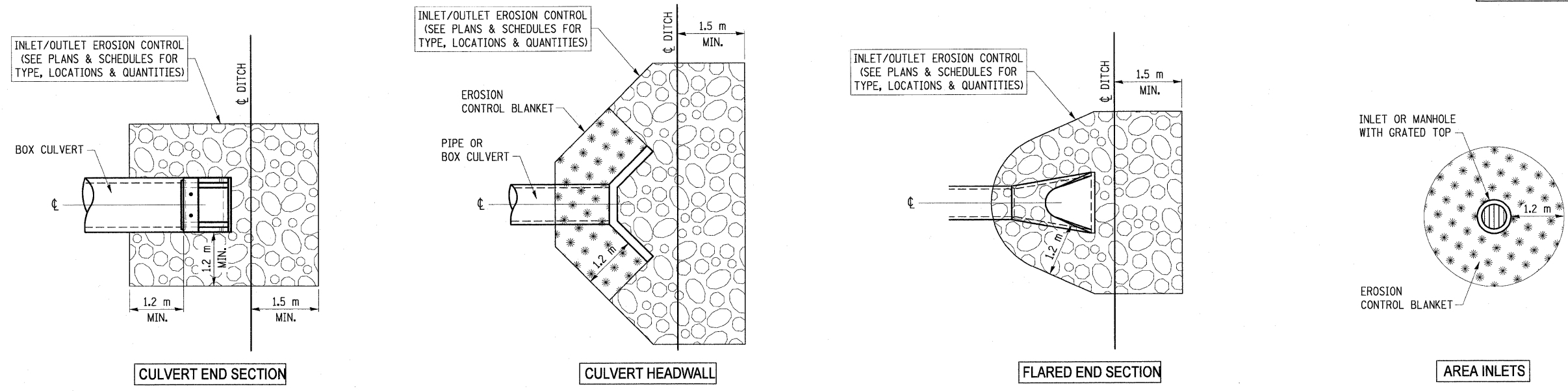

PERMANENT EROSION CONTROL AT INLET/OUTLET STRUCTURES

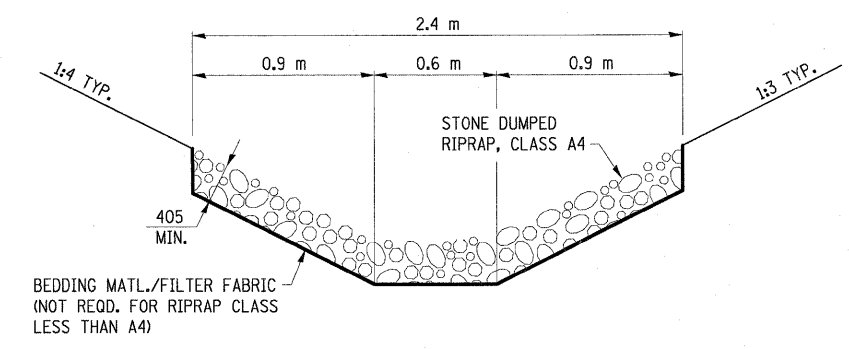

STONED DUMPED RIPRAP (CLASS A4) DETAIL

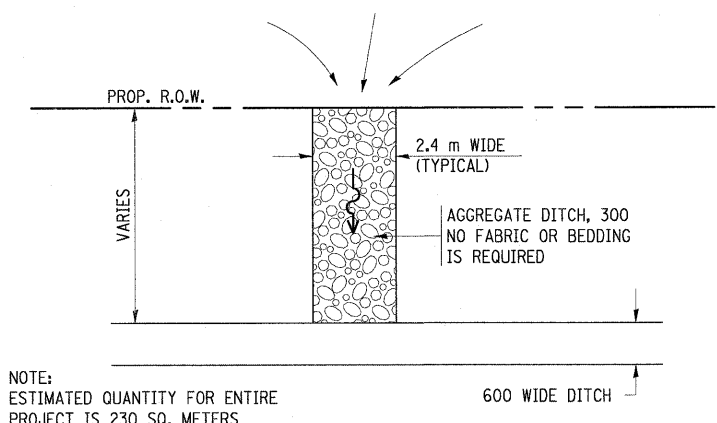

NOTE:
ESTIMATED QUANTITY FOR ENTIRE PROJECT IS 230 SQ. METERS

FIELD DRAINAGE OUTLET DETAIL

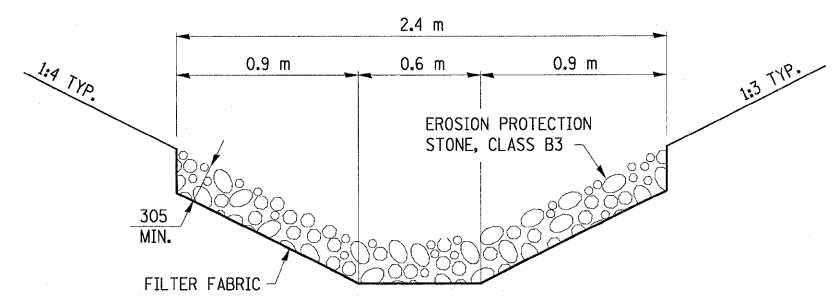

AGGREGATE DITCH DETAIL

ALL DIMENSIONS ARE IN MILLIMETERS UNLESS OTHERWISE SHOWN.

REVISIONS		ILLINOIS DEPARTMENT OF TRANSPORTATION
NAME	DATE	
		<p>PERMANENT EROSION CONTROL DETAILS</p> <p>SCALE NO SCALE DRAWN BY KOJ</p> <p>DATE MARCH 20, 2008 CHECKED BY RGH</p>

PLOT DATE = 3/20/2008
FILE NAME = H:\4420\781\63_detailed.dgn

H. M. & G. NO. 4420

F.A.P. RTE.	SECTION	COUNTY	TOTAL SHEETS	SHEET NO.
781	1YRS, 2ZRS-1	CRAWFORD	378	174
STA.		TO STA.		
FED. ROAD DIST. NO.		ILLINOIS	FED. AID PROJECT	

DETAIL OF PRECAST CONCRETE BOX CULVERT M259M

AASHO DESIGNATION M259M
(ASTM DESIGNATION C-789M)
DESIGN LOADING = MS18

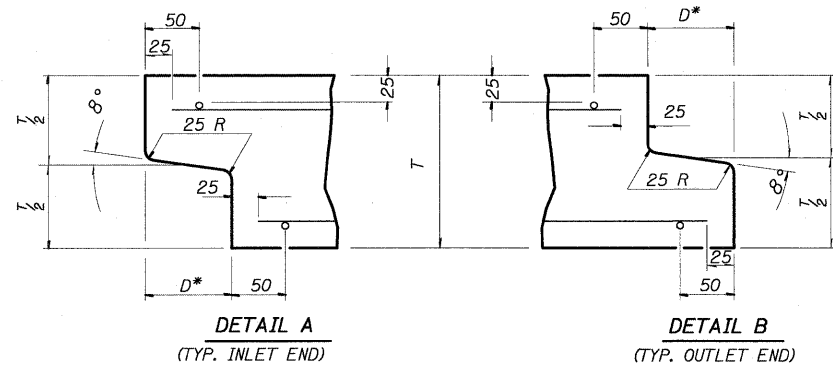

DETAIL A
(TYP. INLET END)
DETAIL B
(TYP. OUTLET END)

NOTE: INLET AND OUTLET ENDS SHALL BE COMPATIBLE.

* THE D DIMENSION SHALL CONFORM TO THE MANUFACTURER'S STANDARDS.

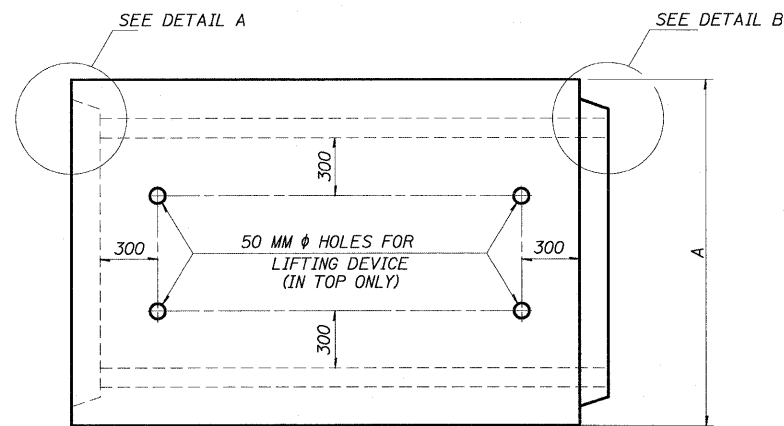

PLAN
LOCATION OF LIFTING HOLES MAY BE VARIED AS NEEDED TO CLEAR REINFORCEMENT.

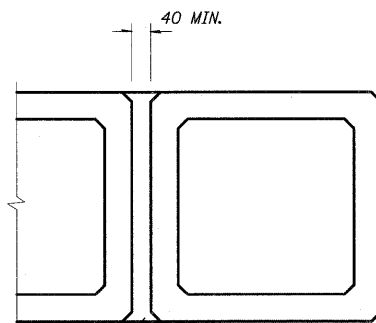

CLASS SI CONCRETE
MULTIPLE UNIT PLACEMENT

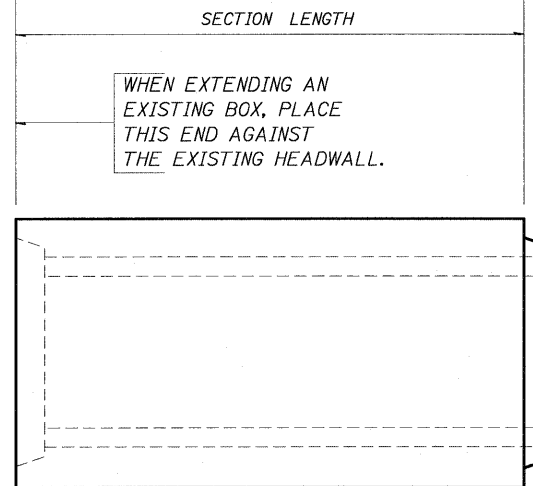

ELEVATION

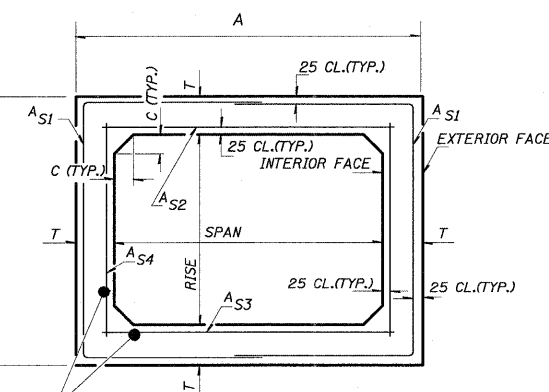

CROSS SECTION

GENERAL NOTES
SHOP PLANS FOR THE REINFORCEMENT SHALL BE SUBMITTED IN ACCORDANCE WITH THE REQUIREMENTS OF ARTICLE 504.04(d) OF THE STANDARD SPECIFICATIONS.

MINIMUM CONCRETE STRENGTH SHALL BE 35 MPa AFTER 28 DAYS.

THE JOINTS OF THE PRECAST BOX SECTIONS SHALL BE SEALED IN ACCORDANCE WITH ARTICLE 542.04(d) OF THE STANDARD SPECIFICATIONS FOR ROAD AND BRIDGE CONSTRUCTION.

THE TERMS A_{S1}, A_{S3}, AND A_{S4} DENOTE THE REQUIRED STEEL AREAS FOR REINFORCEMENT AS SPECIFIED IN ASSHTO M259M. REINFORCEMENT SHALL BE WELDED WIRE FABRIC CONFORMING TO ASSHTO M55M.

LIFTING HOLES SHALL BE FILLED WITH CONCRETE PLUGS AND MASTIC AFTER THE BOX SECTIONS ARE IN PLACE.

DRAINAGE OPENINGS SHALL BE PROVIDED IN ACCORDANCE WITH ARTICLE 503.12 OF THE STANDARD SPECIFICATIONS. LOCATION AND SPACING OF THE OPENINGS SHALL BE SHOWN ON THE SHOP DRAWINGS.

ALL DIMENSIONS ARE DETAILED IN MILLIMETERS UNLESS OTHERWISE NOTED.

CULVERT SIZE		DIMENSIONS			
NOMINAL	ACTUAL	T	A	B	C
SPANxRISE (METER)	SPANxRISE (METER)	(MILLIMETERS)	(METER)	(METER)	(MILLIMETERS)
0.6x0.6	0.610x0.610	100	0.810	0.810	100
0.9x0.6	0.914x0.610	100	1.114	0.810	100
0.9x0.9	0.914x0.914	100	1.114	1.114	100
1.2x0.6	1.219x0.610	125	1.469	0.860	125
1.2x0.9	1.219x0.914	125	1.469	1.164	125
1.2x1.2	1.219x1.219	125	1.469	1.469	125
1.5x0.6	1.524x0.610	150	1.824	0.910	150
1.5x0.9	1.524x0.914	150	1.824	1.214	150
1.5x1.2	1.524x1.219	150	1.824	1.519	150
1.5x1.5	1.524x1.524	150	1.824	1.824	150
1.8x0.6	1.829x0.610	175	2.179	0.960	175
1.8x0.9	1.829x0.914	175	2.179	1.264	175
1.8x1.2	1.829x1.219	175	2.179	1.569	175
1.8x1.5	1.829x1.524	175	2.179	1.874	175
1.8x1.8	1.829x1.829	175	2.179	2.179	175
2.1x1.2	2.134x1.219	200	2.534	1.619	200
2.1x1.5	2.134x1.524	200	2.534	1.924	200
2.1x1.8	2.134x1.829	200	2.534	2.229	200
2.1x2.1	2.134x2.134	200	2.534	2.534	200
2.4x1.2	2.438x1.219	200	2.838	1.619	200
2.4x1.5	2.438x1.524	200	2.838	1.924	200
2.4x1.8	2.438x1.829	200	2.838	2.229	200
2.4x2.1	2.438x2.134	200	2.838	2.534	200
2.4x2.4	2.438x2.438	200	2.838	2.838	200
2.7x1.5	2.743x1.524	225	3.193	1.974	225
2.7x1.8	2.743x1.829	225	3.193	2.279	225
2.7x2.1	2.743x2.134	225	3.193	2.584	225
2.7x2.4	2.743x2.438	225	3.193	2.888	225
2.7x2.7	2.743x2.743	225	3.193	3.193	225
3.0x1.5	3.048x1.524	250	3.548	2.024	250
3.0x1.8	3.048x1.829	250	3.548	2.329	250
3.0x2.1	3.048x2.134	250	3.548	2.634	250
3.0x2.4	3.048x2.438	250	3.548	2.938	250
3.0x2.7	3.048x2.743	250	3.548	3.243	250
3.0x3.0	3.048x3.048	250	3.548	3.548	250
3.3x1.2	3.353x1.219	275	3.903	1.769	275
3.3x1.5	3.353x1.524	275	3.903	2.074	275
3.3x1.8	3.353x1.829	275	3.903	2.379	275
3.3x2.1	3.353x2.134	275	3.903	2.684	275
3.3x2.4	3.353x2.438	275	3.903	2.988	275
3.3x2.7	3.353x2.743	275	3.903	3.293	275
3.3x3.0	3.353x3.048	275	3.903	3.598	275
3.3x3.3	3.353x3.353	275	3.903	3.903	275
3.6x1.2	3.658x1.219	300	4.258	1.819	300
3.6x1.5	3.658x1.524	300	4.258	2.124	300
3.6x1.8	3.658x1.829	300	4.258	2.429	300
3.6x2.1	3.658x2.134	300	4.258	2.734	300
3.6x2.4	3.658x2.438	300	4.258	3.038	300
3.6x2.7	3.658x2.743	300	4.258	3.343	300
3.6x3.0	3.658x3.048	300	4.258	3.648	300
3.6x3.3	3.658x3.353	300	4.258	3.953	300

REVISIONS		ILLINOIS DEPARTMENT OF TRANSPORTATION
NAME	DATE	
		DETAIL OF PRECAST CONCRETE BOX CULVERT SECTION
SCALE	NO SCALE	DRAWN BY KOJ
DATE	MARCH 20, 2008	CHECKED BY RGH

PLOT DATE = 3/20/2008
FILE NAME = H:\4420\70169_details.dgn

F.A.P. RTE.	SECTION	COUNTY	TOTAL SHEETS	SHEET NO.
781	1YRS, 2ZRS-1	CRAWFORD	378	175
STA. TO STA.		ILLINOIS FED. AID PROJECT		

DETAIL OF PRECAST CONCRETE

BOX CULVERT M273M

(WITH LESS THAN 600 MM OF COVER)
 AASHO DESIGNATION M273M
 (ASTM DESIGNATION C-850M)
 DESIGN LOADING = MS18

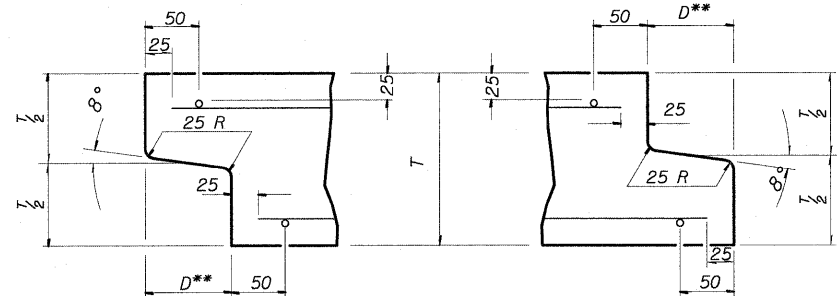

DETAIL A
(TYP. INLET END)
DETAIL B
(TYP. OUTLET END)

NOTE: INLET AND OUTLET ENDS SHALL BE COMPATIBLE.

** THE D DIMENSION SHALL CONFORM TO THE MANUFACTURER'S STANDARDS.

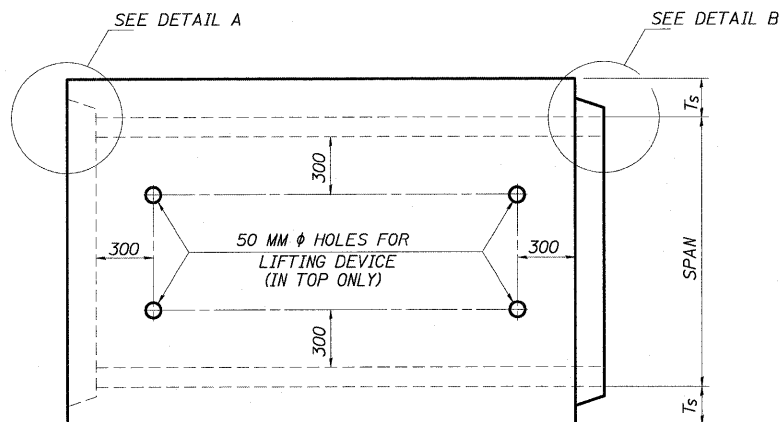

PLAN

LOCATION OF LIFTING HOLES MAY BE VARIED AS NEEDED TO CLEAR REINFORCEMENT.

SECTION LENGTH

WHEN EXTENDING AN EXISTING BOX, PLACE THIS END AGAINST THE EXISTING HEADWALL.

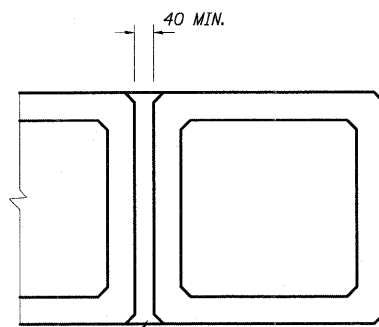

MULTIPLE UNIT PLACEMENT

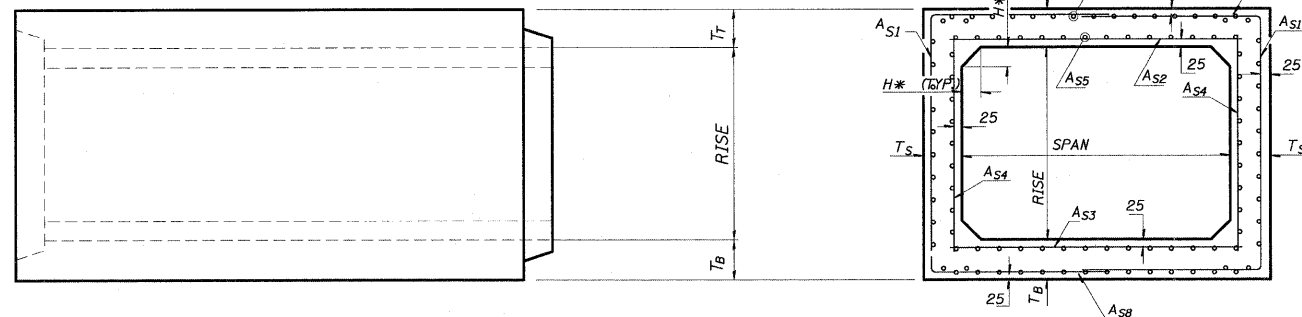

ELEVATION

CROSS SECTION

* THE HAUNCH DIMENSION, H, IS EQUAL TO THE WALL THICKNESS, T_s.

GENERAL NOTES

SHOP PLANS FOR THE REINFORCEMENT SHALL BE SUBMITTED IN ACCORDANCE WITH THE REQUIREMENTS OF ARTICLE 504.04(a) OF THE STANDARD SPECIFICATIONS.

MINIMUM CONCRETE STRENGTH SHALL BE 35 MPa AFTER 28 DAYS.

THE JOINTS OF THE PRECAST BOX SECTIONS SHALL BE SEALED IN ACCORDANCE WITH ARTICLE 542.04(d) OF THE STANDARD SPECIFICATIONS FOR ROAD AND BRIDGE CONSTRUCTION.

THE TERMS A_s1, A_s2, ETC. DENOTE THE REQUIRED STEEL AREAS FOR REINFORCEMENT AS SPECIFIED IN ASSHTO M273M.

REINFORCEMENT SHALL BE WELDED WIRE FABRIC CONFORMING TO ASSHTO M55M. LONGITUDINAL DISTRIBUTION REINFORCEMENT MAY CONSIST OF WELDED WIRE FABRIC OR DEFORMED BARS CONFORMING TO ASSHTO M31M, M42M, OR M53M, GRADE 400.

LIFTING HOLES SHALL BE FILLED WITH CONCRETE PLUGS AND MASTIC AFTER THE BOX SECTIONS ARE IN PLACE.

DRAINAGE OPENINGS SHALL BE PROVIDED IN ACCORDANCE WITH ARTICLE 503.12 OF THE STANDARD SPECIFICATIONS. LOCATION AND SPACING OF THE OPENINGS SHALL BE SHOWN ON THE SHOP DRAWINGS.

THE P.C.C. PAVEMENT PATCH REINFORCED WITH PAVEMENT FABRIC (STANDARD 42070) WILL BE CONSTRUCTED OVER THE CULVERT. THE PATCH SHALL BE FULL PAVEMENT WIDTH, AND THE LENGTH SHALL EXTEND 600 MM BEYOND EACH SIDE OF THE CULVERT.

ALL DIMENSIONS ARE DETAILED IN MILLIMETERS UNLESS OTHERWISE NOTED.

CULVERT SIZE (METERS)				DIMENSIONS (MILLIMETERS)		
NOMINAL		ACTUAL		T _T	T _B	T _S
SPAN	RISE	SPAN	RISE			
0.9	0.6	0.914	0.610	175	150	100
0.9	0.9	0.914	0.914	175	150	100
1.2	0.6	1.219	0.610	190	150	125
1.2	0.9	1.219	0.914	190	150	125
1.2	1.2	1.219	1.219	190	150	125
1.5	0.9	1.524	0.914	200	175	150
1.5	1.2	1.524	1.219	200	175	150
1.5	1.5	1.524	1.524	200	175	150
1.8	0.9	1.829	0.914	200	175	175
1.8	1.2	1.829	1.219	200	175	175
1.8	1.5	1.829	1.524	200	175	175
1.8	1.8	1.829	1.829	200	175	175
2.1	1.2	2.134	1.219	200	200	200
2.1	1.5	2.134	1.524	200	200	200
2.1	1.8	2.134	1.829	200	200	200
2.1	2.1	2.134	2.134	200	200	200
2.4	1.2	2.438	1.219	200	200	200
2.4	1.5	2.438	1.524	200	200	200
2.4	1.8	2.438	1.829	200	200	200
2.4	2.1	2.438	2.134	200	200	200
2.4	2.4	2.438	2.438	200	200	200
2.7	1.5	2.743	1.524	225	225	225
2.7	1.8	2.743	1.829	225	225	225
2.7	2.1	2.743	2.134	225	225	225
2.7	2.4	2.743	2.438	225	225	225
2.7	2.7	2.743	2.743	225	225	225
3.0	1.5	3.048	1.524	250	250	250
3.0	1.8	3.048	1.829	250	250	250
3.0	2.1	3.048	2.134	250	250	250
3.0	2.4	3.048	2.438	250	250	250
3.0	2.7	3.048	2.743	250	250	250
3.0	3.0	3.048	3.048	250	250	250
3.3	1.2	3.353	1.219	275	275	275
3.3	1.8	3.353	1.829	275	275	275
3.3	2.4	3.353	2.438	275	275	275
3.3	3.0	3.353	3.048	275	275	275
3.3	3.3	3.353	3.353	275	275	275
3.6	1.2	3.658	1.219	300	300	300
3.6	1.8	3.658	1.829	300	300	300
3.6	2.4	3.658	2.438	300	300	300
3.6	3.0	3.658	3.048	300	300	300
3.6	3.6	3.658	3.658	300	300	300

REVISIONS		ILLINOIS DEPARTMENT OF TRANSPORTATION
NAME	DATE	
		DETAIL OF PRECAST CONCRETE BOX CULVERT SECTION SCALE NO SCALE DRAWN BY KOJ DATE MARCH 20, 2008 CHECKED BY RGH

PLOT DATE = 3/20/2008
 FILE NAME = H:\4428\Y0189.dwg

H. M. & G. NO. 4420

F.A.P. RTE.	SECTION	COUNTY	TOTAL SHEETS	SHEET NO.
781	1YRS, 2ZRS-1	CRAWFORD	378	176
STA.		TO STA.		
FED. ROAD DIST. NO.		ILLINOIS	FED. AID PROJECT	

DETAIL OF PRECAST CONCRETE BOX CULVERT END SECTION

AASHTO DESIGNATION M259M
(ASTM DESIGNATION C-789M)
DESIGN LOADING = MS18

*** NOTE: THE DIMENSIONS INDICATED ARE FOR END SECTIONS THAT ARE TO BE USED WITH PRECAST BOX CULVERT SECTIONS DESIGNED FOR 600 MM OR MORE OF FILL. THE DIMENSIONS MUST BE MODIFIED FOR THE END SECTION TO BE COMPATIBLE WITH PRECAST CULVERT SECTIONS DESIGNED FOR LESS THAN 600 MM OF FILL.

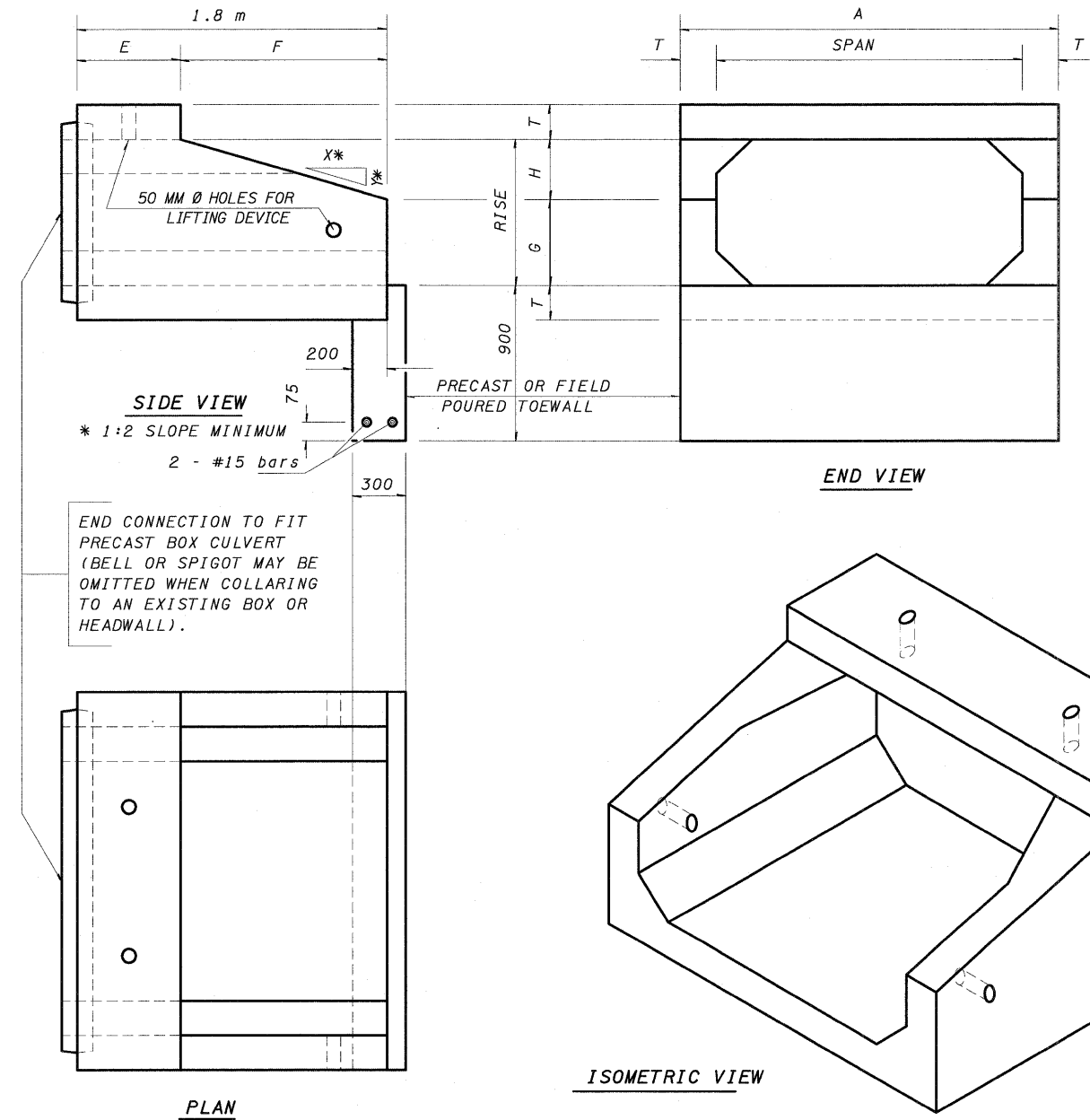
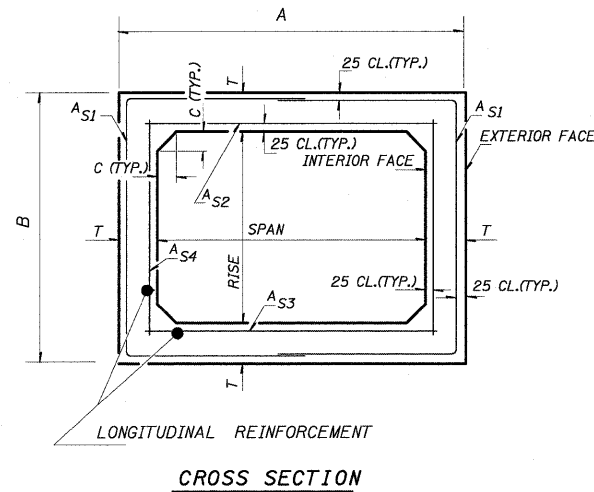

CULVERT SIZE		DIMENSIONS **								
NOMINAL	ACTUAL	T	A	B	C	E	F	G	H	SLOPE
SPANxRISE (METER)	SPANxRISE (METER)	(MM)	(METER)	(METER)	(MM)	(METER)	(METER)	(METER)	(METER)	(Y:X)
0.6x0.6	0.610x0.610	100	0.810	0.810	100	0.900	0.900	0.310	0.300	1:3
0.9x0.6	0.914x0.610	100	1.114	0.810	100	0.900	0.900	0.310	0.300	1:3
0.9x0.9	0.914x0.914	100	1.114	1.114	100	0.600	1.200	0.514	0.400	1:3
1.2x0.6	1.219x0.610	125	1.469	0.860	125	0.900	0.900	0.310	0.300	1:3
1.2x0.9	1.219x0.914	125	1.469	1.164	125	0.600	1.200	0.514	0.400	1:3
1.2x1.2	1.219x1.219	125	1.469	1.469	125	0.600	1.200	0.619	0.600	1:2
1.5x0.6	1.524x0.610	125	1.774	0.860	150	0.900	0.900	0.310	0.300	1:3
1.5x0.9	1.524x0.914	150	1.824	1.214	150	0.600	1.200	0.514	0.400	1:3
1.5x1.2	1.524x1.219	150	1.824	1.519	150	0.600	1.200	0.619	0.600	1:2
1.5x1.5	1.524x1.524	150	1.824	1.824	150	0.600	1.200	0.924	0.600	1:2
1.8x0.6	1.829x0.610	175	2.179	0.960	175	0.900	0.900	0.310	0.300	1:3
1.8x0.9	1.829x0.914	175	2.179	1.264	175	0.600	1.200	0.514	0.400	1:3
1.8x1.2	1.829x1.219	175	2.179	1.569	175	0.600	1.200	0.619	0.600	1:2
1.8x1.5	1.829x1.524	175	2.179	1.874	175	0.600	1.200	0.619	0.600	1:2
1.8x1.8	1.829x1.829	175	2.179	2.179	175	0.600	1.200	0.619	0.600	1:2
2.1x1.2	2.134x1.219	200	2.534	1.619	200	0.600	1.200	0.619	0.600	1:2
2.1x1.5	2.134x1.524	200	2.534	1.924	200	0.600	1.200	0.619	0.600	1:2
2.1x1.8	2.134x1.829	200	2.534	2.229	200	0.600	1.200	0.619	0.600	1:2
2.1x2.1	2.134x2.134	200	2.534	2.534	200	0.600	1.200	0.619	0.600	1:2
2.4x1.2	2.438x1.219	200	2.838	1.619	200	0.600	1.200	0.619	0.600	1:2
2.4x1.5	2.438x1.524	200	2.838	1.924	200	0.600	1.200	0.619	0.600	1:2
2.4x1.8	2.438x1.829	200	2.838	2.229	200	0.600	1.200	0.619	0.600	1:2
2.4x2.1	2.438x2.134	200	2.838	2.534	200	0.600	1.200	0.619	0.600	1:2
2.4x2.4	2.438x2.438	200	2.838	2.838	200	0.600	1.200	0.619	0.600	1:2
2.7x1.5	2.743x1.524	225	3.193	1.974	225	0.600	1.200	0.619	0.600	1:2
2.7x1.8	2.743x1.829	225	3.193	2.279	225	0.600	1.200	0.619	0.600	1:2
2.7x2.1	2.743x2.134	225	3.193	2.584	225	0.600	1.200	0.619	0.600	1:2
2.7x2.4	2.743x2.438	225	3.193	2.888	225	0.600	1.200	0.619	0.600	1:2
2.7x2.7	2.743x2.743	225	3.193	3.193	225	0.600	1.200	0.619	0.600	1:2
3.0x1.5	3.048x1.524	250	3.548	2.024	250	0.600	1.200	0.619	0.600	1:2
3.0x1.8	3.048x1.829	250	3.548	2.329	250	0.600	1.200	0.619	0.600	1:2
3.0x2.1	3.048x2.134	250	3.548	2.634	250	0.600	1.200	0.619	0.600	1:2
3.0x2.4	3.048x2.438	250	3.548	2.938	250	0.600	1.200	0.619	0.600	1:2
3.0x2.7	3.048x2.743	250	3.548	3.243	250	0.600	1.200	0.619	0.600	1:2
3.0x3.0	3.048x3.048	250	3.548	3.548	250	0.600	1.200	0.619	0.600	1:2
3.3x1.2	3.353x1.219	275	3.903	1.769	275	0.600	1.200	0.619	0.600	1:2
3.3x1.8	3.353x1.829	275	3.903	2.379	275	0.600	1.200	0.619	0.600	1:2
3.3x2.4	3.353x2.438	275	3.903	2.988	275	0.600	1.200	0.619	0.600	1:2
3.3x3.0	3.353x3.048	275	3.903	3.598	275	0.600	1.200	0.619	0.600	1:2
3.3x3.3	3.353x3.353	275	3.903	3.903	275	0.600	1.200	0.619	0.600	1:2
3.6x1.2	3.658x1.219	300	4.258	1.819	300	0.600	1.200	0.619	0.600	1:2
3.6x1.8	3.658x1.829	300	4.258	2.429	300	0.600	1.200	0.619	0.600	1:2
3.6x2.4	3.658x2.438	300	4.258	3.038	300	0.600	1.200	0.619	0.600	1:2
3.6x3.0	3.658x3.048	300	4.258	3.648	300	0.600	1.200	0.619	0.600	1:2
3.6x3.6	3.658x3.658	300	4.258	4.258	300	0.600	1.200	0.619	0.600	1:2

GENERAL NOTES

SHOP PLANS FOR THE REINFORCEMENT SHALL BE SUBMITTED IN ACCORDANCE WITH THE REQUIREMENTS OF ARTICLE 504.04(a) OF THE STANDARD SPECIFICATIONS.

THE TERMS AS1, AS2, AS3, AND AS4 DENOTE THE REQUIRED STEEL AREAS FOR REINFORCEMENT AS SPECIFIED IN AASHTO M259M. REINFORCEMENT SHALL BE WELDED WIRE FABRIC CONFORMING TO AASHTO SPECIFICATIONS M55M.

MINIMUM CONCRETE STRENGTH SHALL BE 35 MPa AFTER 28 DAYS.

ALL DIMENSIONS ARE DETAILED IN MILLIMETERS UNLESS OTHERWISE NOTED.

THE JOINTS OF THE PRECAST BOX SECTIONS SHALL BE SEALED WITH ACCORDANCE WITH ARTICLE 542.04(d) OF THE STANDARD SPECIFICATIONS FOR ROAD AND BRIDGE CONSTRUCTION.

LIFTING HOLES SHALL BE FILLED WITH CONCRETE PLUGS AND MASTIC AFTER THE END SECTIONS ARE IN PLACE.

REVISIONS		ILLINOIS DEPARTMENT OF TRANSPORTATION
NAME	DATE	
		DETAIL OF PRECAST CONCRETE BOX CULVERT END SECTION
SCALE	NO SCALE	DRAWN BY KOJ
DATE	MARCH 20, 2008	CHECKED BY RGH

PLOT DATE = 3/20/2008
FILE NAME = H:\4428\781\69_sch\en11.dgn

F.A.P. RTE.	SECTION	COUNTY	TOTAL SHEETS	SHEET NO.
781	1YRS, 2ZRS-1	CRAWFORD	378	182
STA.		TO STA.		
FED. ROAD DIST. NO.		ILLINOIS	FED. AID PROJECT	

GENERAL NOTES

- Plan dimensions and details relative to existing structure have been taken from existing plans and are subject to nominal construction variations. It shall be the Contractor's responsibility to verify such dimensions and details in the field and make necessary approved adjustments prior to construction or ordering of materials. Such variations shall not be cause for additional compensation for a change in the scope of the work, however, the Contractor will be paid for the quantity actually furnished at the unit price bid for the work.
- Expansion bolts shall consist of approved expansion anchors, providing minimum certified proof load = 18.15 kN, and 20 mm ϕ hooked bolts shall extend a minimum of 250 mm into new concrete.
- Reinforcement bars shall conform to the requirements of AASHTO M-31M or M-322M, Grade 400.
- Reinforcement bars designated (E) shall be epoxy coated.
- All dimensions are in millimeters (mm) except as noted.
- Precast reinforced concrete box sections shall conform to AASHTO M-259M and M-273M.
- Layout of the slope protection system may be varied to suit ground conditions in the field as directed by the Engineer.

DESIGN SPECIFICATIONS

2002 AASHTO Specifications

DESIGN STRESSES (New Construction)

<i>Field Units</i>	<i>Precast Units</i>
$f'_c = 24 \text{ MPa}$	$f'_c = 35 \text{ MPa}$
$f_y = 400 \text{ MPa (Reinf.)}$	$f_y = 450 \text{ MPa (Welded wire fabric)}$
$f_y = 250 \text{ MPa (Str. Steel)}$	

LOADING MS18

Allow 1.2 kN/m² For future wearing surface

INDEX OF SHEETS

S1	Gen. Notes & Bill of Material
S2	General Plan & Elevation, Box Culvert No. 1
S3	General Plan & Elevation, Box Culvert No. 4
S4	Concrete Repair Details, Box Culvert No. 4
S5	General Plan & Elevation, Box Culvert No. 8
S6	Concrete Repair Details, Box Culvert No. 8
S7	General Plan & Elevation, Box Culvert No. 10
S8	Concrete Repair Details, Box Culvert No. 10
S9	General Plan & Elevation, Box Culvert No. 11
S10	Concrete Repair Details, Box Culvert No. 11
S11	General Plan & Elevation, Box Culvert No. 15
S12	General Plan & Elevation, Box Culvert No. 16
S13	General Plan & Elevation, Box Culvert No. 17
S14	Concrete Repair Details, Box Culvert No. 17
S15	Precast Section Details
S16	Precast End Section Details
S17	Cast-In-Place Collar Details
S18	Miscellaneous Details
S19	Plug & Fill Details, E.C. #101 And E.C. #105

TOTAL BILL OF MATERIAL

(Culverts E.C. 101, 105) (Box Culvert Nos. 1, 4, 8, 10, 11, 15, 16 & 17)

Item	Unit	Total
M5030350 Concrete Structures	cu. m.	4.9
M5080205 Reinforcement Bars, Epoxy Coated	kg	880
* M5401010 Precast Concrete Box Culvert (3000x1650)	m	10.9
* M5401010 Precast Concrete Box Culvert (900x600)	m	5.7
* Precast Concrete Box Culvert (900x450)	m	15.2
* M5401005 Precast Concrete Box Culvert (600x600)	m	15.6
* M5401002 Precast Concrete Box Culvert (600x450)	m	15.1
* 5401001 Box Culvert End Section, Culvert No. 1	Each	2
* 5401004 Box Culvert End Section, Culvert No. 4	Each	2
* 5401008 Box Culvert End Section, Culvert No. 8	Each	2
* 5401010 Box Culvert End Section, Culvert No. 10	Each	2
* 5401011 Box Culvert End Section, Culvert No. 11	Each	2
* 5401015 Box Culvert End Section, Culvert No. 15	Each	2
* 5401016 Box Culvert End Section, Culvert No. 16	Each	2
* 5401017 Box Culvert End Section, Culvert No. 17	Each	2
M5403220 Expansion Bolts (M20x250)	Each	206
M2810707 Stone Riprap, Class A4	sq. m.	See Plans
M5050405 Furnishing & Erecting Structural Steel	kg	260
MX033694 Structural Repair of Concrete (Depth Equal to or Less than 125mm)	sq. m.	3.2
M5900200 Epoxy Crack Injection	m	5
MX032196 Polymer Modified Portland Cement Mortar	sq. m.	25.9
M5930100 Controlled Low-Strength Material	cu. m.	7.0

* Non-standard size.

REVISIONS		ILLINOIS DEPARTMENT OF TRANSPORTATION BOX CULVERT EXTENSIONS GEN. NOTES & BILL OF MATERIAL
NAME	DATE	
		SCALE NONE DATE DECEMBER 10, 2006 DRAWN BY MLB CHECKED BY MTH

F.A.P. RTE.	SECTION	COUNTY	TOTAL SHEETS	SHEET NO.
781	1YRS, 2ZRS-1	CRAWFORD	378	183
STA.		TO STA.		
FED. ROAD DIST. NO.		ILLINOIS	FED. AID PROJECT	

Existing Structure: The structure is a single barrel 914 mm x 457 mm box culvert at a skew of 0°52'01" right forward. The culvert has an overall length of 9.69 m. The contractor shall extend the culvert on each end for the dimensions shown.

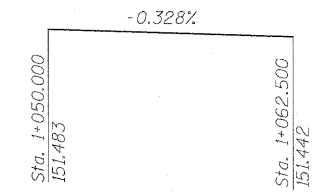
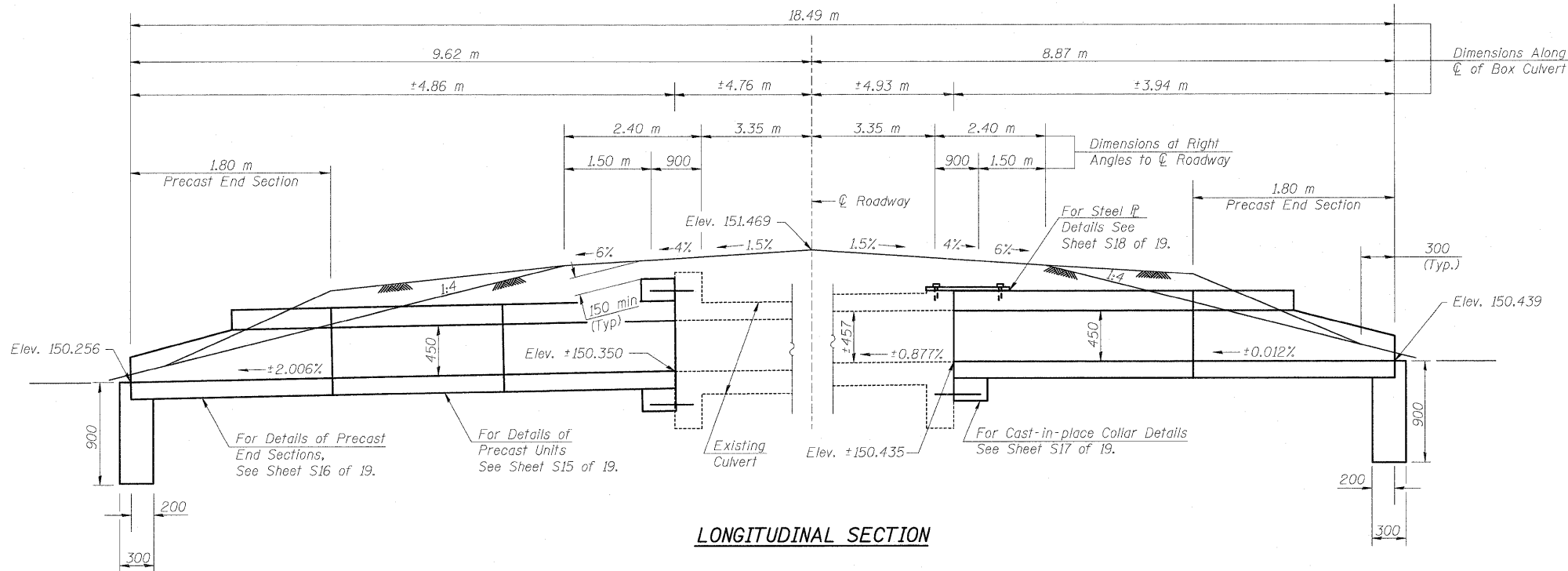

PROFILE GRADE

BILL OF MATERIAL - BOX CULVERT NO. 1

Item	Unit	Total
M5030350 Concrete Structures	cu. m.	0.5
M5080205 Reinforcement Bars, Epoxy Coated	kg	90
Precast Concrete Box Culvert (900x450)	m	5.2
* 5401001 Box Culvert End Section, Culvert No. 1	Each	2
M5403220 Expansion Bolts (M20x250)	Each	21
M2810707 Stone Riprap, Class A4	sq. m.	See Plans
M5050405 Furnishing & Erecting Structural Steel	kg	130

* Non-standard size.

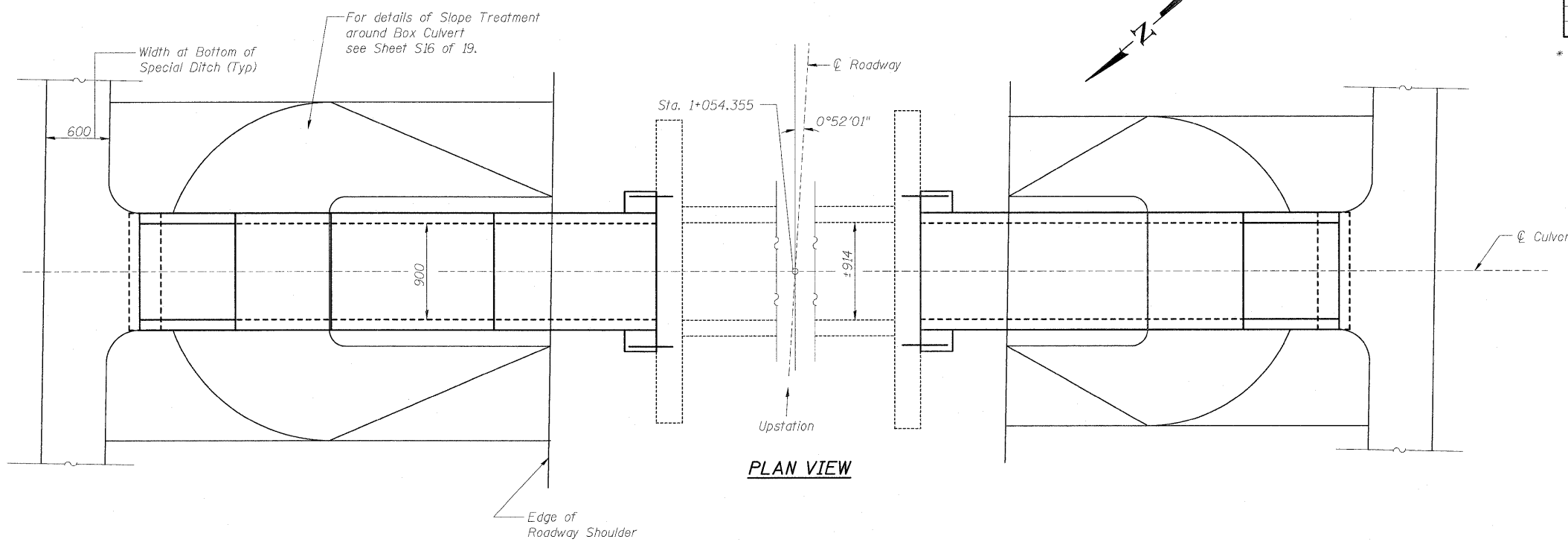

PLAN VIEW

PLOT DATE = 3/20/2008
FILE NAME = H:\4420\4420.5\Lin_Eng\design_files\12-18-2006\S-02.dgn

REVISIONS		ILLINOIS DEPARTMENT OF TRANSPORTATION BOX CULVERT EXTENSIONS GENERAL PLAN & ELEVATION BOX CULV. NO. 1, STA. 1+054.355
NAME	DATE	
		SCALE NONE DATE DECEMBER 10, 2006 DRAWN BY MLB CHECKED BY MTH

F.A.P. RTE.	SECTION	COUNTY	TOTAL SHEETS	SHEET NO.
781	1YRS, 2ZRS-1	CRAWFORD	378	184
STA.		TO STA.		
FED. ROAD DIST. NO.		ILLINOIS	FED. AID PROJECT	

Existing Structure: The structure is a single barrel 610 mm x 488 mm box culvert at a skew of 0°49'55" right forward. The culvert has an overall length of 10.95 m. The contractor shall extend the culvert on each end for the dimensions shown.

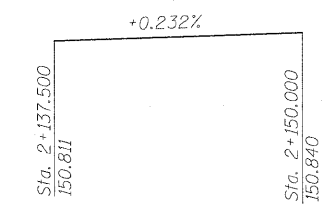
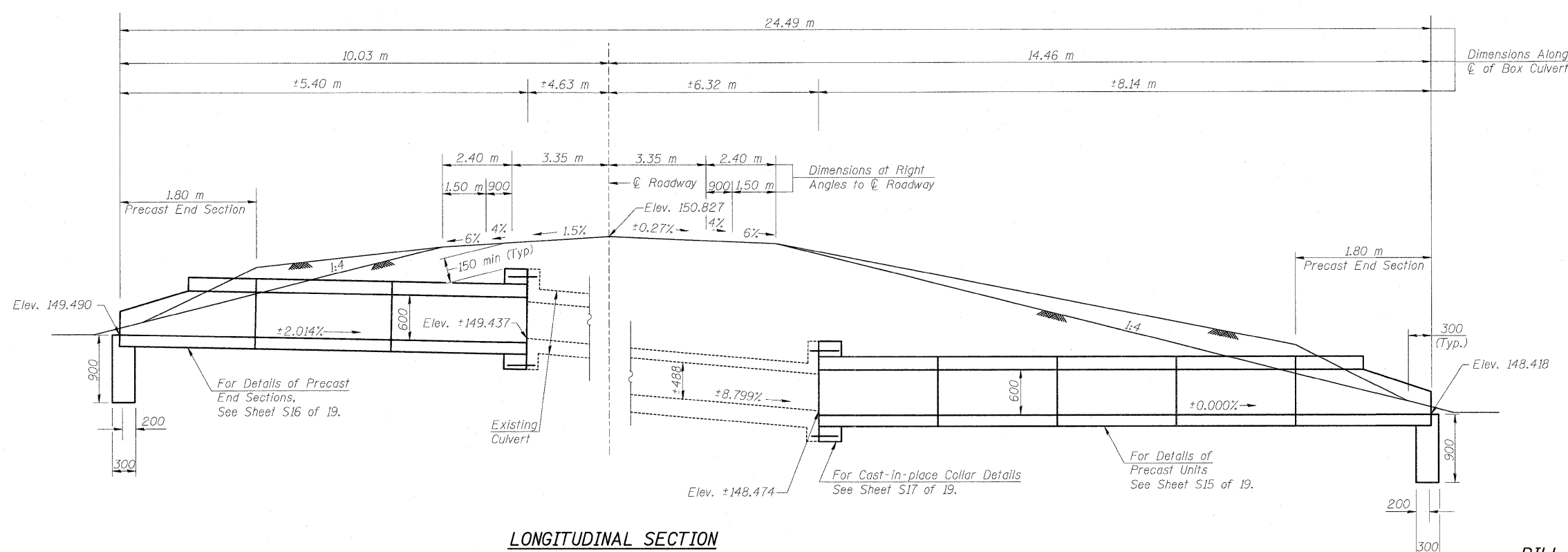

PROFILE GRADE

CURVE P2 DATA

PI Sta. 2+006.106
 $\Delta = 41^\circ 59' 15''$ (LT)
 T = 118.158 m
 R = 307.912 m
 L = 225.644 m
 E = 21.893 m
 S.E. = 6.0%
 PC Sta. 1+887.948
 PT Sta. 2+113.592
 Attain S.E. Sta. 1+847.948 to 1+901.948
 And Sta. 2+099.592 to 2+153.592

BILL OF MATERIAL - BOX CULVERT NO. 4

Item	Unit	Total
M5030350 Concrete Structures	cu. m.	0.5
M5080205 Reinforcement Bars, Epoxy Coated	kg	100
* M5401005 Precast Concrete Box Culvert (600x600)	m	9.9
* 5401004 Box Culvert End Section, Culvert No. 4	Each	2
M5403220 Expansion Bolts (M20x250)	Each	24
M2810707 Stone Riprap, Class A4	sq. m.	See Plans

* Non-standard size.

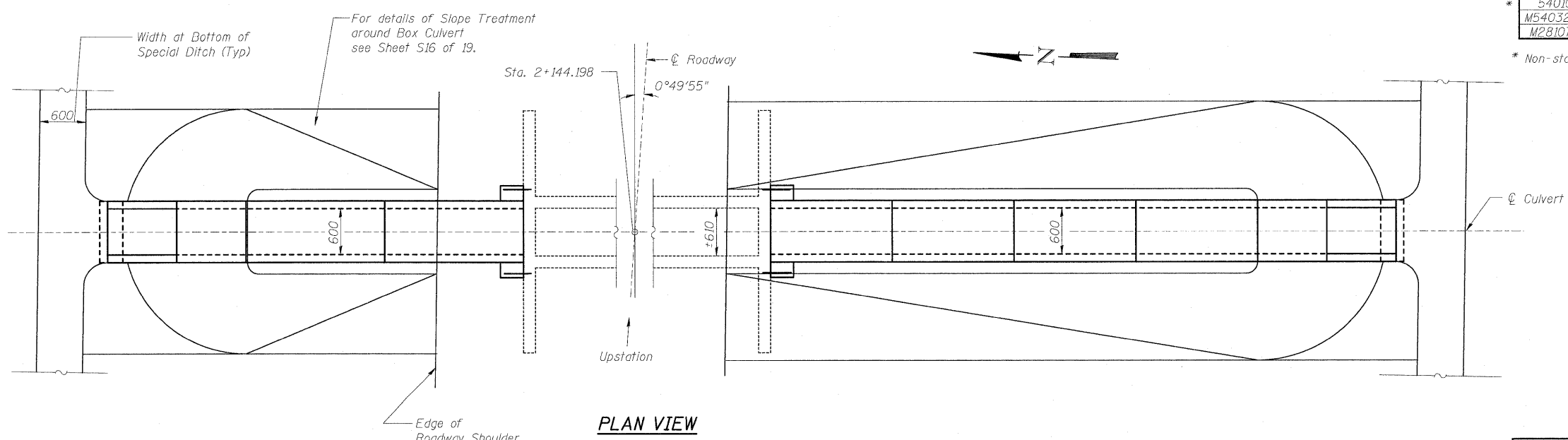

PLAN VIEW

PLOT DATE = 3/29/2008
 FILE NAME = H:\4420\4420.5 (Lin. Eng)\design files\12-18-2006\IS-03.dgn

REVISIONS	
NAME	DATE

ILLINOIS DEPARTMENT OF TRANSPORTATION
BOX CULVERT EXTENSIONS
GENERAL PLAN & ELEVATION
BOX CULV. NO. 4, STA. 2+144.198

SCALE NONE DRAWN BY MLB
 DATE DECEMBER 10, 2006 CHECKED BY MTH

F.A.P. RTE.	SECTION	COUNTY	TOTAL SHEETS	SHEET NO.
781	1YBS_2ZRS-1	CRAWFORD	378	186
STA. _____		TO STA. _____		
FED. ROAD DIST. NO. _____		ILLINOIS	FED. AID PROJECT	

Existing Structure: The structure is a single barrel 3048 mm x 1676 mm box culvert at a skew of 1°32'22" right forward. The culvert has an overall length of 9.82 m. The contractor shall extend the culvert on each end for the dimensions shown.

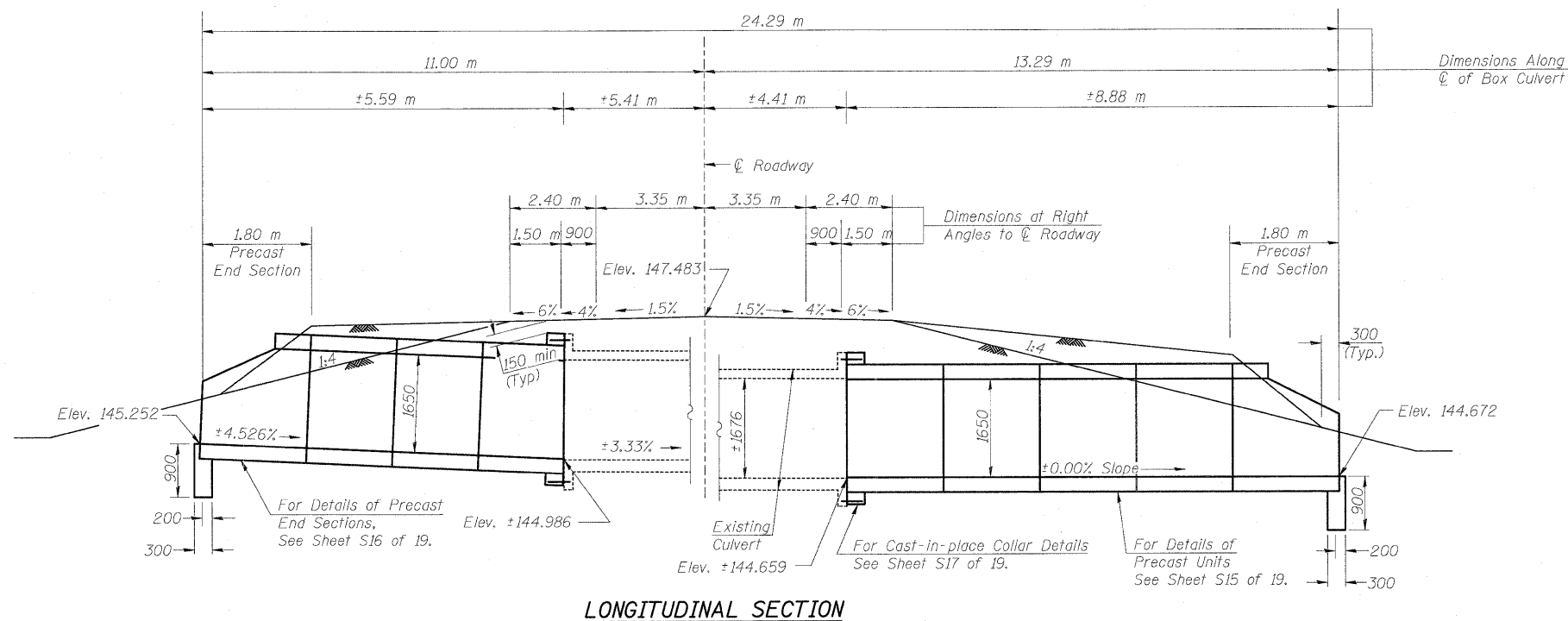

LONGITUDINAL SECTION

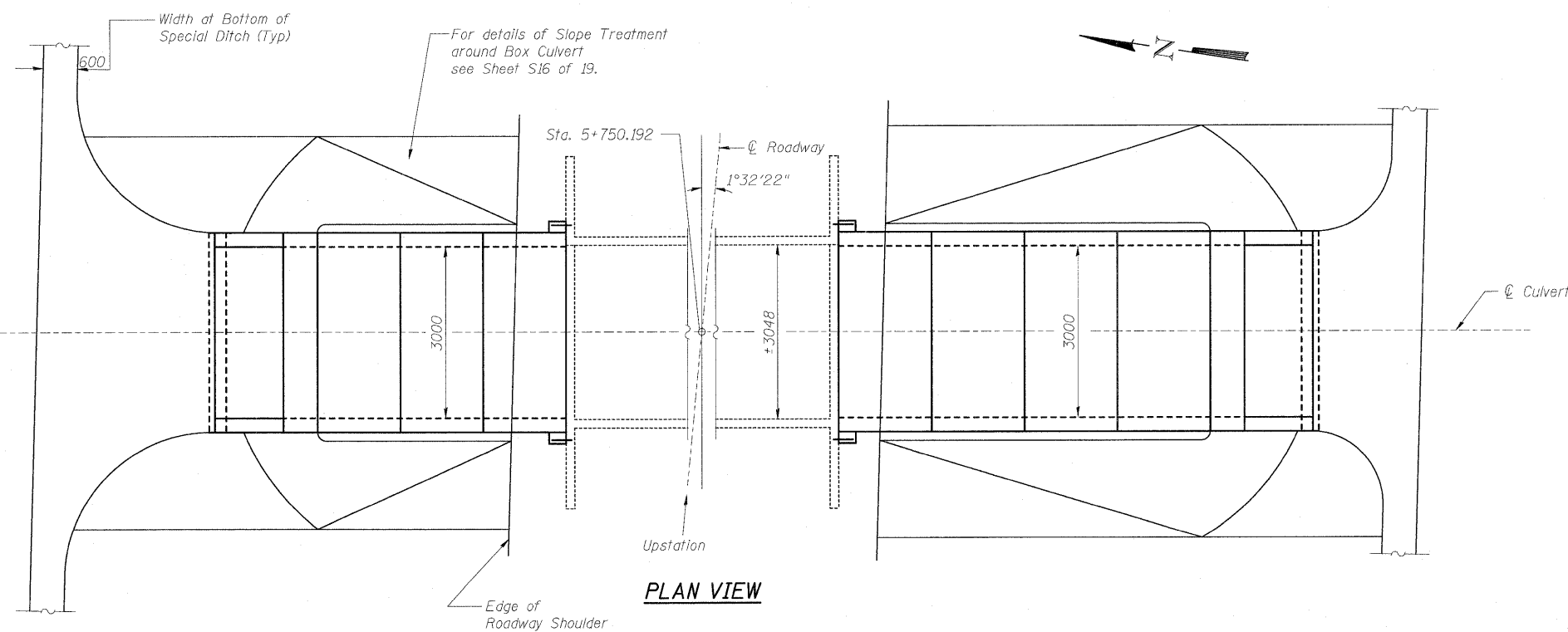

PLAN VIEW

BILL OF MATERIAL - BOX CULVERT NO. 8

Item	Unit	Total
M5030350 Concrete Structures	cu. m.	1.5
M5080205 Reinforcement Bars, Epoxy Coated	kg	220
* M5080205 Precast Concrete Box Culvert (3000x1650)	m	10.9
* M5401008 Box Culvert End Section, Culvert No. 8	Each	2
M5403220 Expansion Bolts (M20x250)	Each	52
M2810707 Stone Riprap, Class A4	sq. m.	See Plans

* Non-standard size.

SHEET S5 OF 19

REVISIONS		ILLINOIS DEPARTMENT OF TRANSPORTATION BOX CULVERT EXTENSIONS GENERAL PLAN & ELEVATION BOX CULV. NO. 8, STA. 5+750.192
NAME	DATE	
		SCALE NONE DATE DECEMBER 10, 2006 DRAWN BY MLB CHECKED BY MTH

PLOT DATE = 3/20/2008
FILE NAME = H:\4420\44205 (Lin Eng)\design files\12-18-2006\IS-05.dgn

LIN NO. 9803

F.A.P. RTE.	SECTION	COUNTY	TOTAL SHEETS	SHEET NO.
781	1YRS, 2ZRS-1	CRAWFORD	378	188
STA.	TO STA.			
FED. ROAD DIST. NO.	ILLINOIS	FED. AID PROJECT		

Existing Structure: The structure is a single barrel 610 mm x 457 mm box culvert at a skew of 0°6'56" right forward. The culvert has an overall length of 9.84 m. The contractor shall extend the culvert on each end for the dimensions shown.

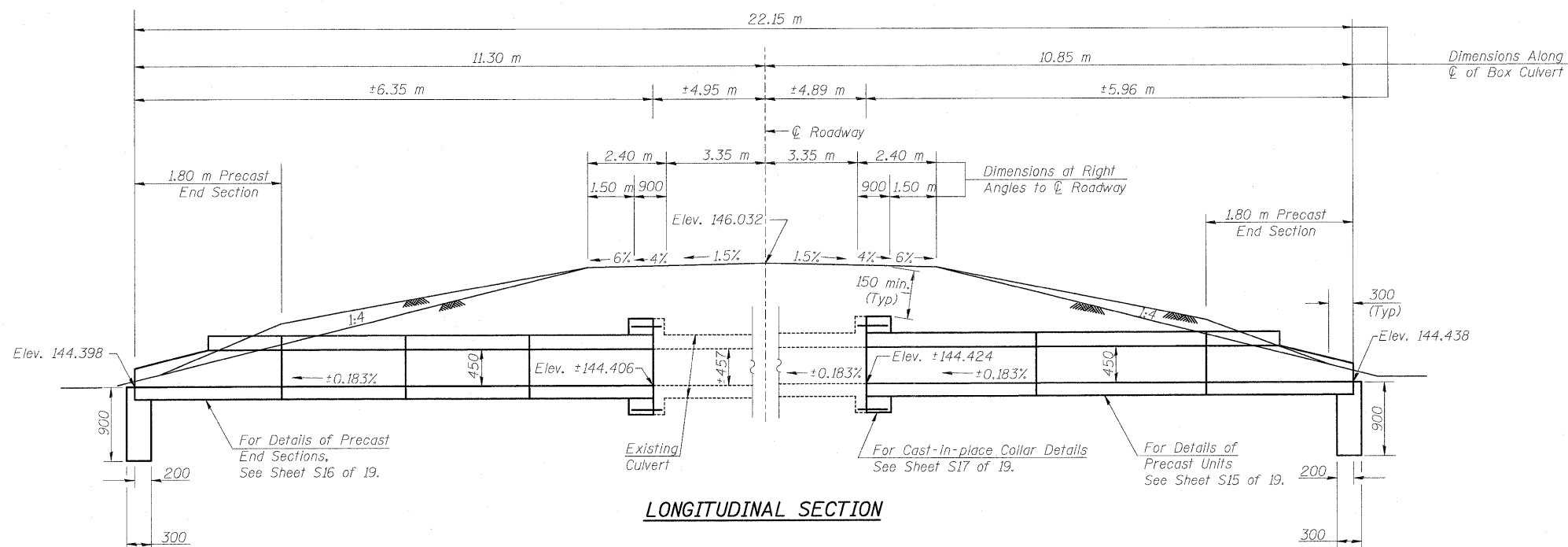

PROFILE GRADE

BILL OF MATERIAL - BOX CULVERT NO. 10

Item	Unit	Total
M5030350 Concrete Structures	cu. m.	0.4
M5080205 Reinforcement Bars, Epoxy Coated	kg	90
M5401002 Precast Concrete Box Culvert (600x450)	m	8.7
* 5401010 Box Culvert End Section, Culvert No. 10	Each	2
* M5403220 Expansion Bolts (M20x250)	Each	20
M2810707 Stone Riprap, Class A4	sq. m.	See Plans

* Non-standard size.

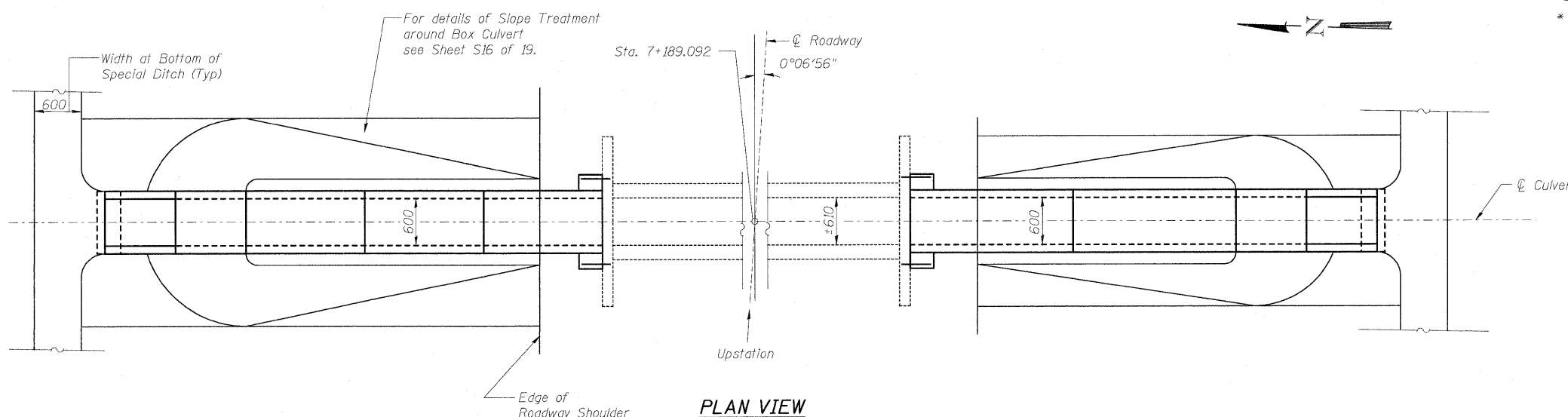

PLAN VIEW

PLOT DATE = 3/20/2008 FILE NAME = H:\4420\44205\Lin Eng\design Files\12-18-2006\IS-07.dgn

REVISIONS		ILLINOIS DEPARTMENT OF TRANSPORTATION BOX CULVERT EXTENSIONS GENERAL PLAN & ELEVATION BOX CULV. NO. 10, STA. 7+189.092
NAME	DATE	
		SCALE NONE DATE DECEMBER 10, 2006 DRAWN BY MLB CHECKED BY MTH

LIN NO. 9803

F.A.P. RTE.	SECTION	COUNTY	TOTAL SHEETS	SHEET NO.
781	1YRS, 2ZRS-1	CRAWFORD	378	189
STA.		TO STA.		
FED. ROAD DIST. NO.	ILLINOIS	FED. AID PROJECT		

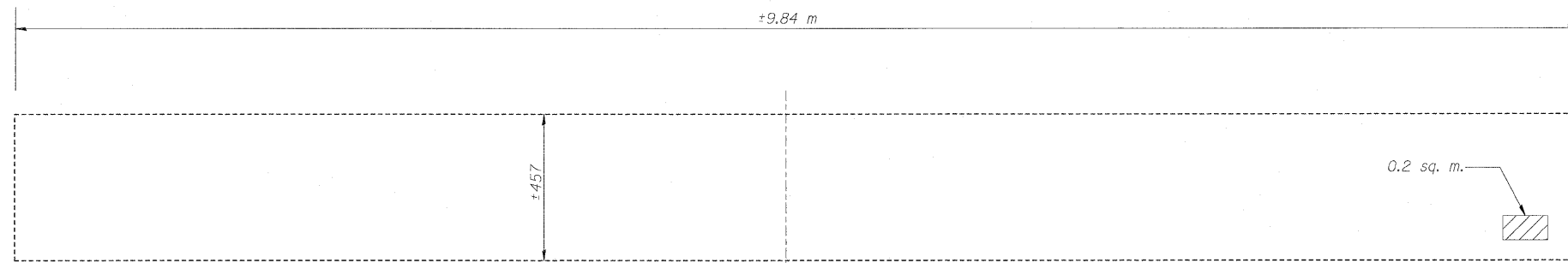

EAST WALL
(Looking East)

Note:

The quantities shown are for estimating purposes only. The actual area to be repaired will be determined by the Engineer at the time of construction. Actual repair locations shall be shown on the "As Built" plans.

LEGEND

- Polymer Modified Portland Cement Mortar
- sq. m. - Square Meter

BILL OF MATERIAL - BOX CULVERT NO. 10

Item	Unit	Total
MX032196 Polymer Modified Portland Cement Mortar	sq. m.	0.3

Quantity increased by 20% to account for deterioration since field inspection.

REVISIONS		ILLINOIS DEPARTMENT OF TRANSPORTATION BOX CULVERT EXTENSIONS CONCRETE REPAIR DETAILS BOX CULV. NO. 10, STA. 7+189.092
NAME	DATE	
		SCALE NONE DATE DECEMBER 10, 2006 DRAWN BY MLB CHECKED BY MTH

PLOT DATE = 3/20/2008
FILE NAME = H:\4420\4420.5\Lin Eng\design files 12-18-2006\5-98.dgn

LIN NO. 9803

F.A.P. RTE.	SECTION	COUNTY	TOTAL SHEETS	SHEET NO.
781	1YRS, 2ZRS-1	CRAWFORD	378	190
STA.		TO STA.		
FED. ROAD DIST. NO.		ILLINOIS	FED. AID PROJECT	

Existing Structure: The structure is a single barrel 914 mm x 610 mm box culvert at a skew of 0°07'08" right forward. The culvert has an overall length of 9.73 m. The contractor shall extend the culvert on each end for the dimensions shown.

CURVE P11 DATA

PI STA. 7+419.751
 $\Delta = 9^\circ 10' 39''$ (LT)
 T = 46.658 m
 R = 581.332 m
 L = 93.117 m
 E = 1.869 m
 S.E. = 5.0%
 PC STA 7+373.093
 PT STA 7+466.210

Attain S.E. Sta. 7+338.093 to 7+385.093
 and Sta. 7+454.210 to 7+501.210

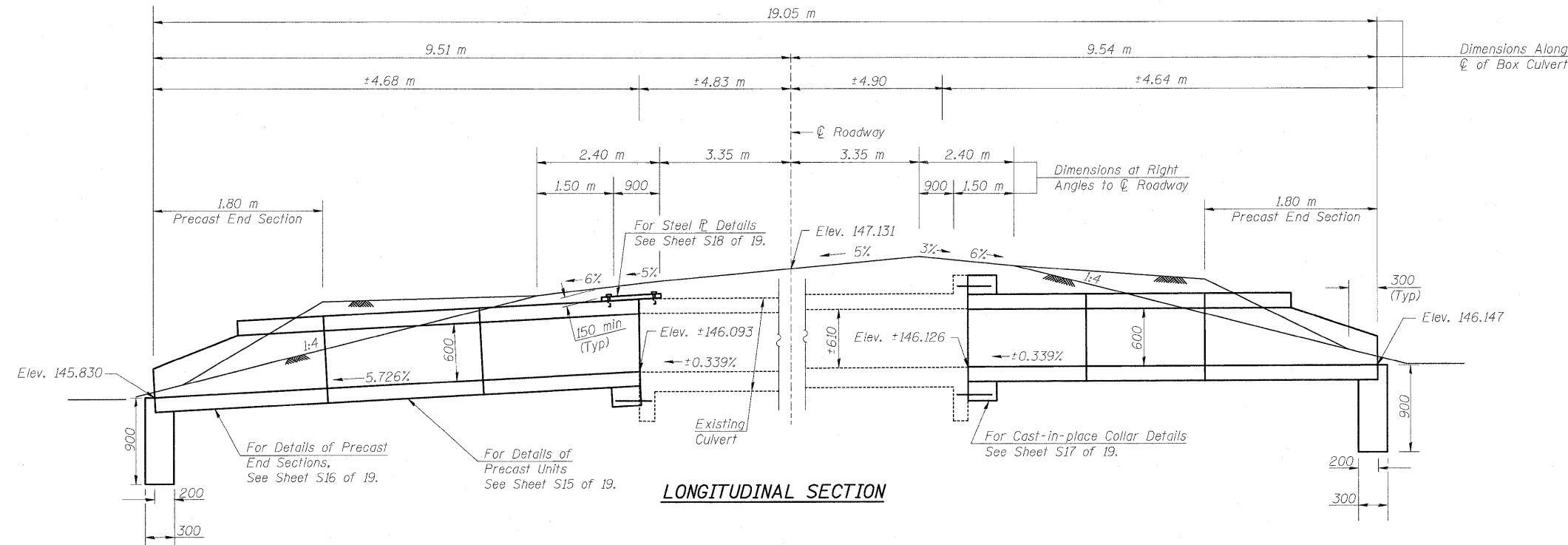

LONGITUDINAL SECTION

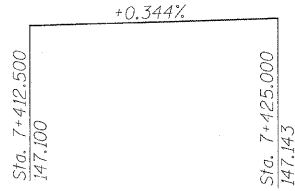

PROFILE GRADE

BILL OF MATERIAL - BOX CULVERT NO. 11

Item	Unit	Total
M5030350 Concrete Structures	cu. m.	0.5
M5080205 Reinforcement Bars, Epoxy Coated	kg	90
M5401005 Precast Concrete Box Culvert (900x600)	m	5.7
5401011 Box Culvert End Section, Culvert No. 11	Each	2
M5403220 Expansion Bolts (M20x250)	Each	21
M2810707 Stone Riprap, Class A4	sq. m.	See Plans
M5050405 Furnishing & Erecting Structural Steel	kg	130

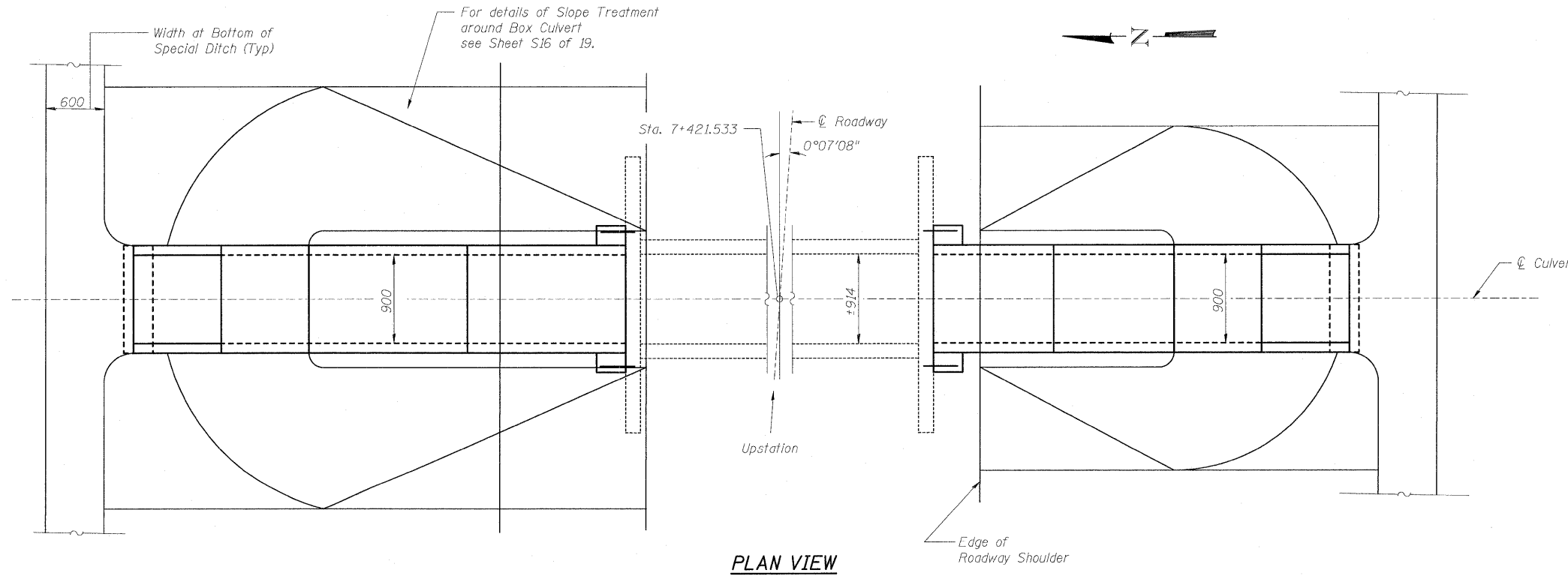

PLAN VIEW

REVISIONS		ILLINOIS DEPARTMENT OF TRANSPORTATION BOX CULVERT EXTENSIONS GENERAL PLAN & ELEVATION BOX CULV. NO. 11, STA. 7+421.533
NAME	DATE	
		SCALE NONE
		DATE DECEMBER 10, 2006
		DRAWN BY MLB
		CHECKED BY MTH

PLOT DATE = 3/20/2008
 FILE NAME = H:\4420\4420.5 (Lin. Eng)\design_files\12-18-2006\SS-08.dgn

LIN NO. 9803

F.A.P. RTE.	SECTION	COUNTY	TOTAL SHEETS	SHEET NO.
781	1YRS, 2ZRS-1	CRAWFORD	378	193
STA.		TO STA.		
FED. ROAD DIST. NO.	ILLINOIS	FED. AID PROJECT		

Existing Structure: The structure is a single barrel 914 mm x 457 mm box culvert at a skew of 1°10'09" right forward. The culvert has an overall length of 9.80 m. The contractor shall extend the culvert on each end for the dimensions shown.

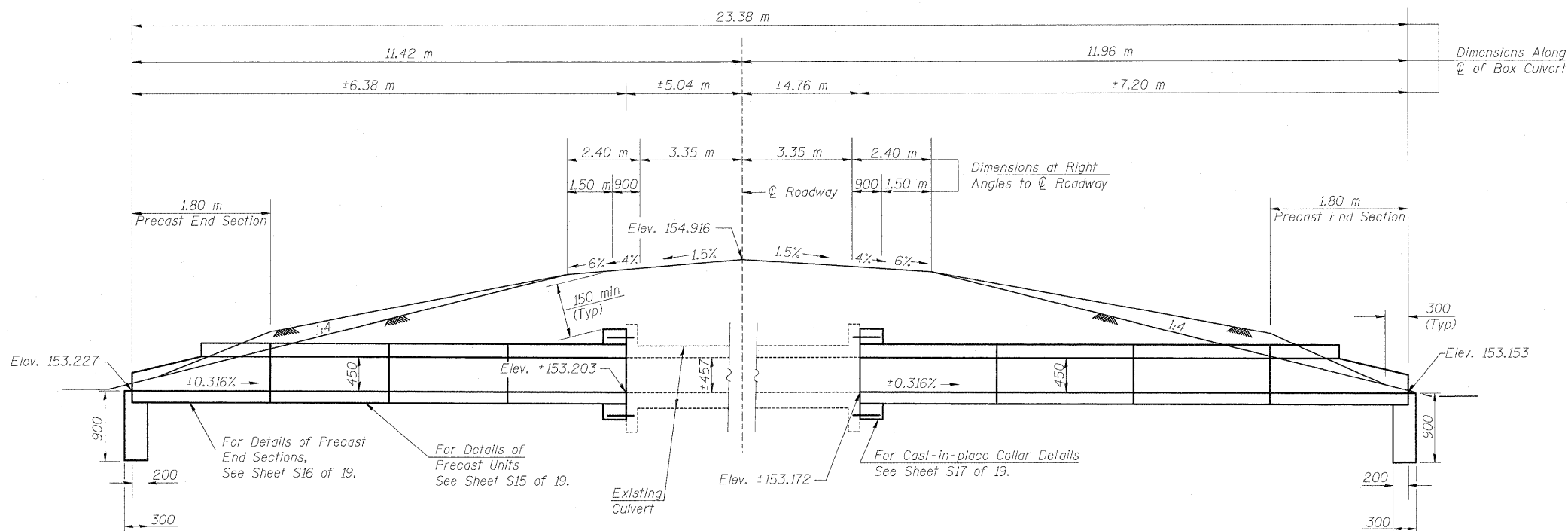

LONGITUDINAL SECTION

BILL OF MATERIAL - BOX CULVERT NO. 16

Item	Unit	Total
M5030350 Concrete Structures	cu. m.	0.5
M5080205 Reinforcement Bars, Epoxy Coated	kg	100
* Precast Concrete Box Culvert (900x450)	m	10.0
* 5401016 Box Culvert End Section, Culvert No. 16	Each	2
M5403220 Expansion Bolts (M20x250)	Each	20
M2810707 Stone Riprap, Class A4	sq. m.	See Plans

* Non-standard size.

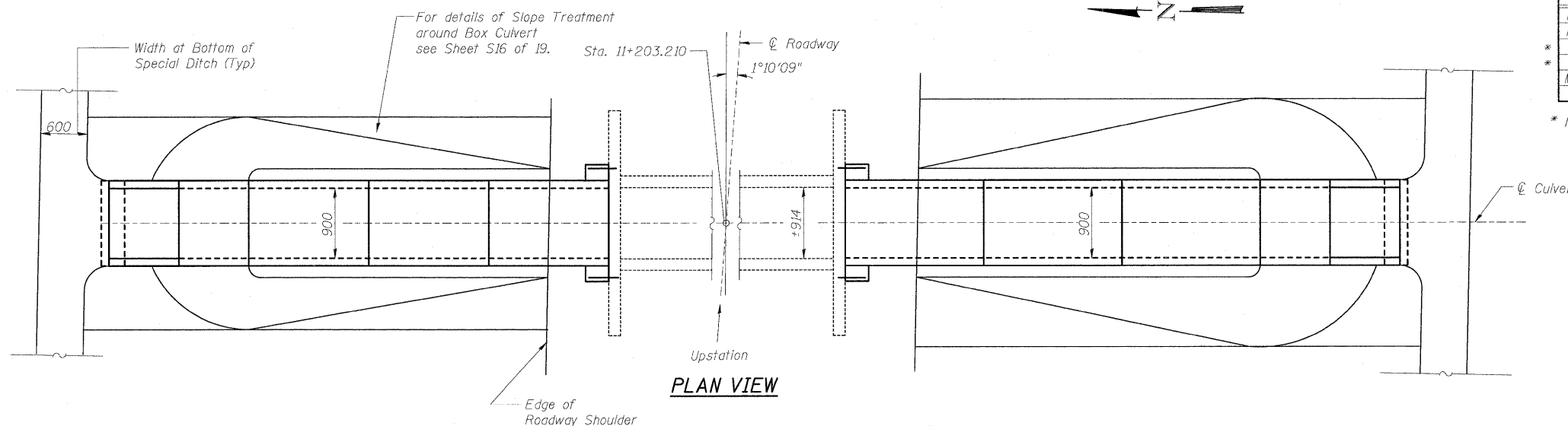

PLAN VIEW

REVISIONS		ILLINOIS DEPARTMENT OF TRANSPORTATION BOX CULVERT EXTENSIONS GENERAL PLAN & ELEVATION BOX CULV. NO. 16, STA. 11+203.210
NAME	DATE	
		SCALE NONE
		DATE DECEMBER 10, 2006
		DRAWN BY MLB
		CHECKED BY MTH

PLOT DATE = 3/20/2008
FILE NAME = H:\14420\4420.5\Lin Eng\design files\12-18-2006\IS-12.dgn

LIN NO. 9803

F.A.P. RTE.	SECTION	COUNTY	TOTAL SHEETS	SHEET NO.
781	1YRS, 2ZRS-1	CRAWFORD	378	194
STA.		TO STA.		
FED. ROAD DIST. NO.		ILLINOIS	FED. AID PROJECT	

Existing Structure: The structure is a single barrel 610 mm x 610 mm box culvert at a skew of 0°08'02" right forward. The culvert has an overall length of 9.65 m. The contractor shall extend the culvert on each end for the dimensions shown.

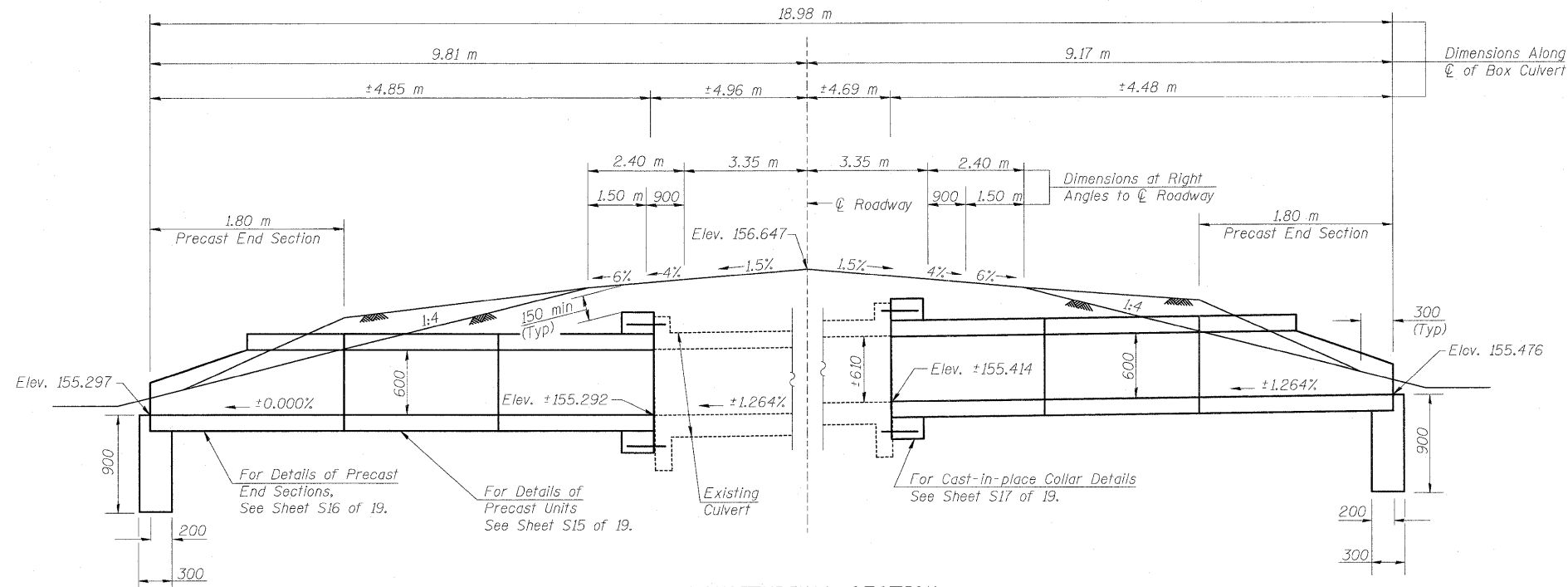

LONGITUDINAL SECTION

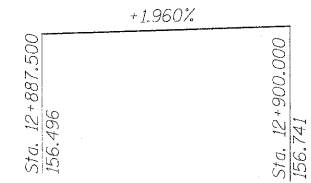

PROFILE GRADE

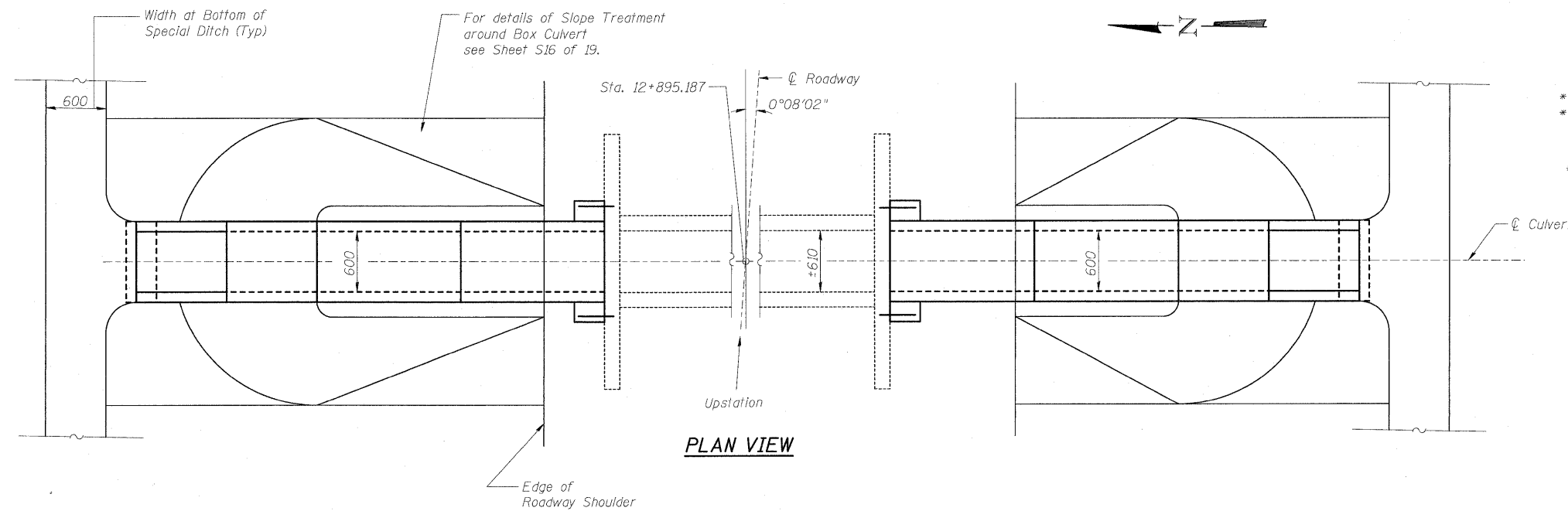

PLAN VIEW

BILL OF MATERIAL - BOX CULVERT NO. 17

Item	Unit	Total
M5030350 Concrete Structures	cu. m.	0.5
M5080205 Reinforcement Bars, Epoxy Coated	kg	100
* M5401005 Precast Concrete Box Culvert (600x600)	m	5.7
* 5401017 Box Culvert End Section, Culvert No. 17	Each	2
M5403220 Expansion Bolts (M20x250)	Each	24
M2810707 Stone Riprap, Class A4	sq. m.	See Plans

* Non-standard size.

PLOT DATE = 3/20/2008
FILE NAME = H:\4420\4420.5 (Lin Eng)\design files 12-18-2006\S-13.dgn

REVISIONS		ILLINOIS DEPARTMENT OF TRANSPORTATION BOX CULVERT EXTENSIONS GENERAL PLAN & ELEVATION BOX CULV. NO. 17, STA. 12+895.187
NAME	DATE	
		SCALE NONE DATE DECEMBER 10, 2006 DRAWN BY MLB CHECKED BY MTH

F.A.P. RTE.	SECTION	COUNTY	TOTAL SHEETS	SHEET NO.
781	1YRS, 2ZRS-1	CRAWFORD	378	195
STA.		TO STA.		
FED. ROAD DIST. NO.	ILLINOIS	FED. AID PROJECT		

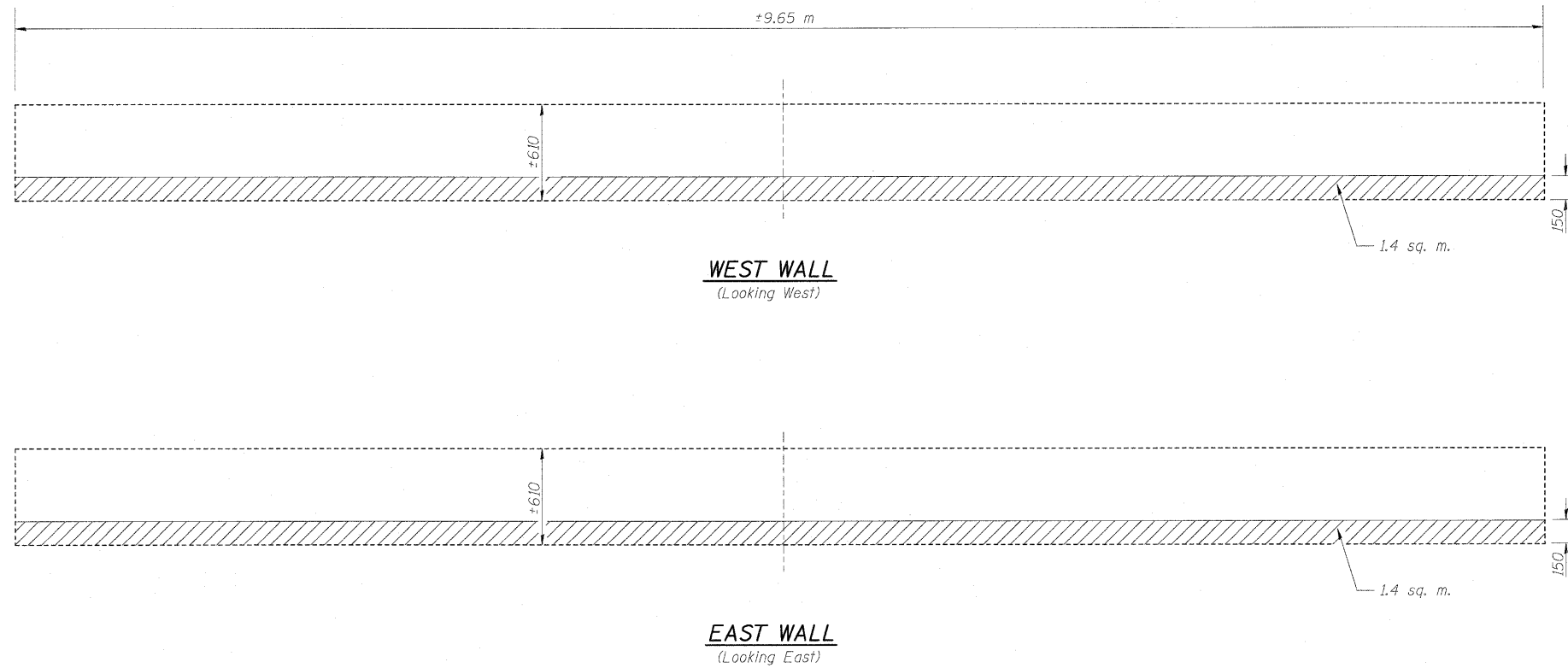

Note:

The quantities shown are for estimating purposes only. The actual area to be repaired will be determined by the Engineer at the time of construction. Actual repair locations shall be shown on the "As Built" plans.

LEGEND

- Polymer Modified Portland Cement Mortar
- sq. m. - Square Meter

BILL OF MATERIAL - BOX CULVERT NO. 17

Item	Unit	Total
MX032196 Polymer Modified Portland Cement Mortar	sq. m.	3.4

Quantity increased by 20% to account for deterioration since field inspection.

PLOT DATE = 3/29/2008
FILE NAME = H:\4420\442015 (Lin Eng)\design files\12-18-2006\IS-14.dgn

REVISIONS		ILLINOIS DEPARTMENT OF TRANSPORTATION BOX CULVERT EXTENSIONS CONCRETE REPAIR DETAILS BOX CULV. NO. 17, STA. 12+895.187
NAME	DATE	

SCALE NONE DRAWN BY MLB
DATE DECEMBER 10, 2006 CHECKED BY MTH

LIN NO. 9803

F.A.P. RTE.	SECTION	COUNTY	TOTAL SHEETS	SHEET NO.
781	1YRS, 2ZRS-1	CRAWFORD	378	196
STA.		TO STA.		
FED. ROAD DIST. NO.		ILLINOIS	FED. AID PROJECT	

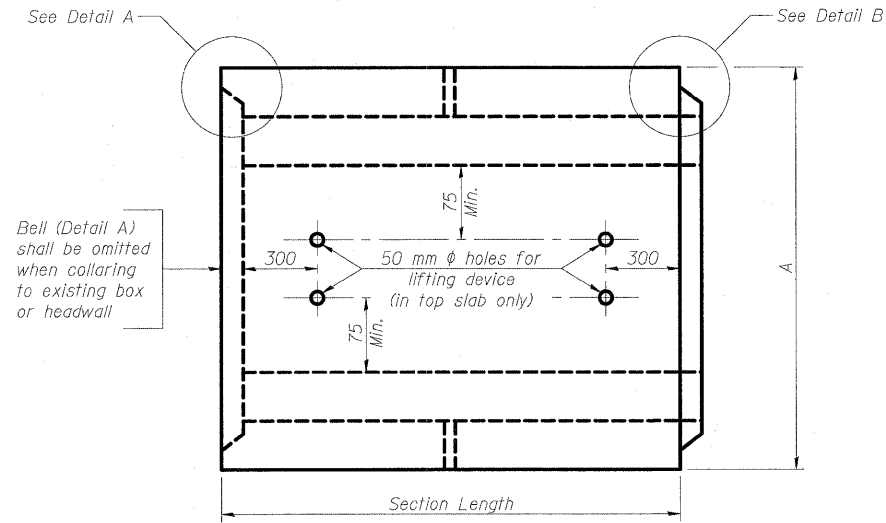

PLAN

Location of lifting holes may be varied as needed to clear reinforcement.

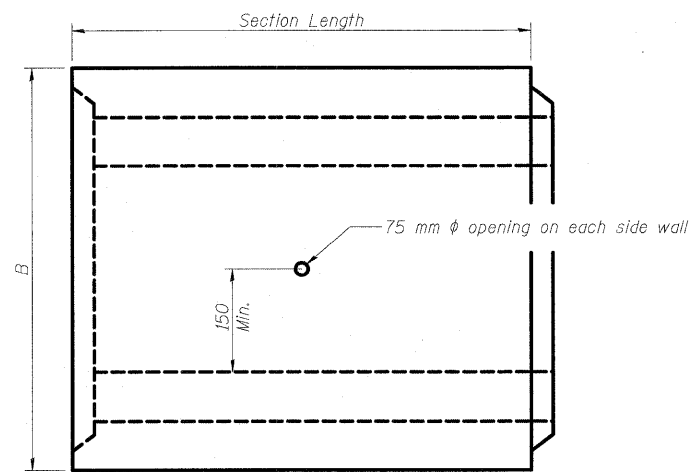

ELEVATION

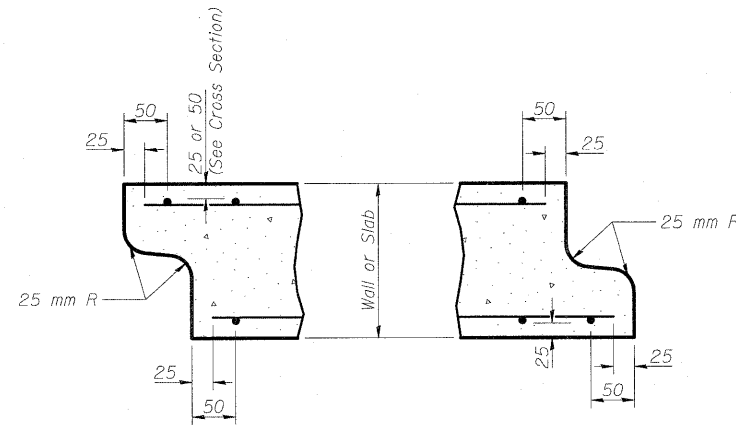

DETAIL A

(Typ. Inlet End)

DETAIL B

(Typ. Outlet End)

NOTES: Inlet and outlet ends shall be compatible.
End detail is subject to variation by fabricator.

Box Culvert No.	Span	Rise	Fill Depth at Shoulder	Design Specifications
1	900	450	< 0.6m	M-273M
4	600	600	< 0.6m	M-273M
8	3000	1650	< 0.6m	M-273M
10	600	450	> 0.6m	M-259M
11	900	600	< 0.6m	M-273M
15	600	450	< 0.6m	M-273M
16	900	450	> 0.6m	M-259M
17	600	600	< 0.6m	M-273M

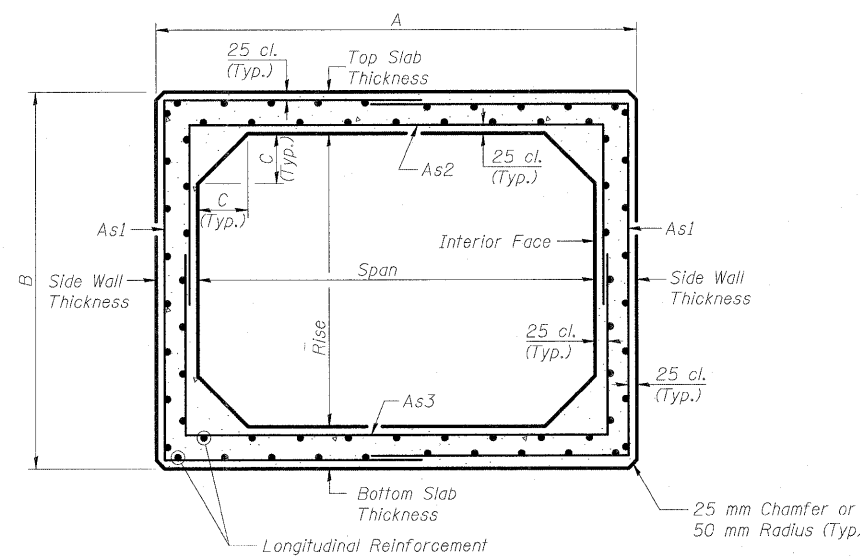

CROSS SECTION

(AASHTO M-259M)

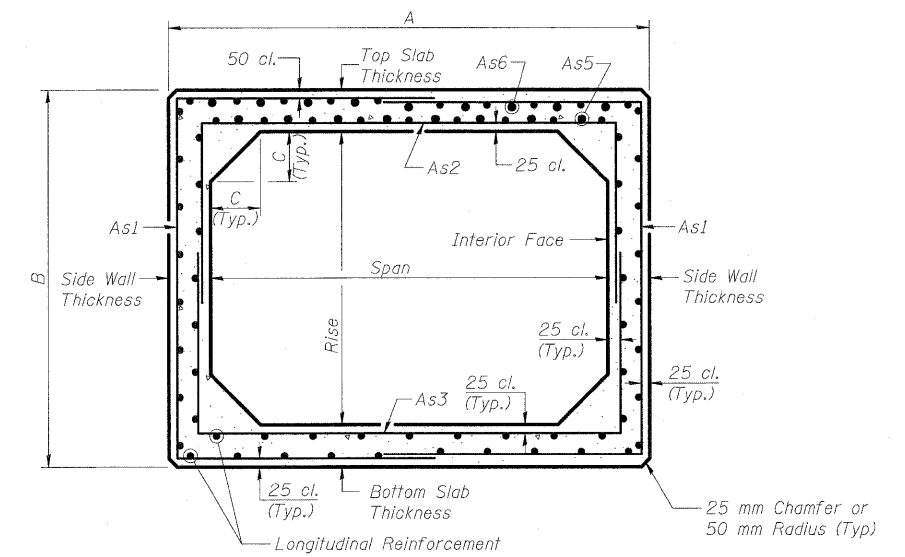

CROSS SECTION

(AASHTO M-273M)

GENERAL NOTES

- The Contractor shall determine box culvert dimensions A, B & C and reinforcement requirements which satisfy AASHTO M-259M or M-273M.
- The terms As1 thru As6 denote the required steel areas for reinforcement as specified in AASHTO M-259M and M-273M.
- Reinforcement shall be welded wire fabric conforming to ASTM specifications A-185.
- Splicing and laps shall conform to AASHTO M-259 and ASTM C-789.
- Lifting holes shall be filled with concrete plugs and mastic after box sections are in place.
- Edge beam reinforcement shall be provided per requirements of AASHTO M-273M.

REVISIONS		ILLINOIS DEPARTMENT OF TRANSPORTATION BOX CULVERT EXTENSIONS PRECAST SECTION DETAILS
NAME	DATE	
		SCALE NONE DATE DECEMBER 10, 2006 DRAWN BY MLB CHECKED BY MTH

F.A.P. RTE.	SECTION	COUNTY	TOTAL SHEETS	SHEET NO.
781	1YRS, 2ZRS-1	CRAWFORD	378	197
STA.		TO STA.		
FED. ROAD DIST. NO.		ILLINOIS	FED. AID PROJECT	

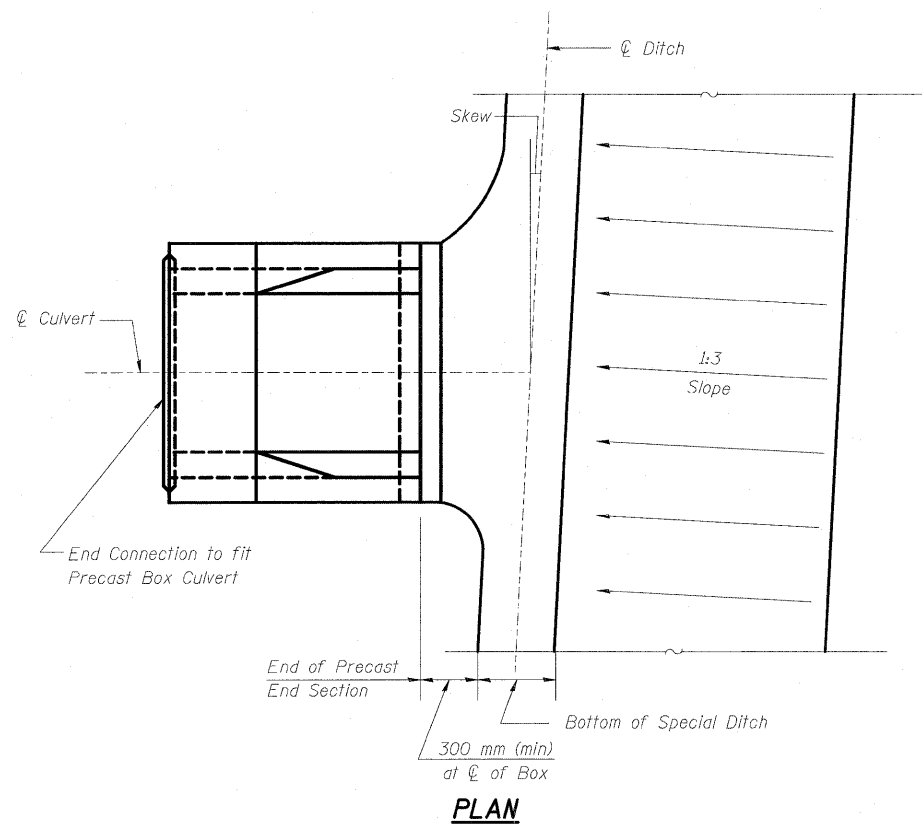

PLAN

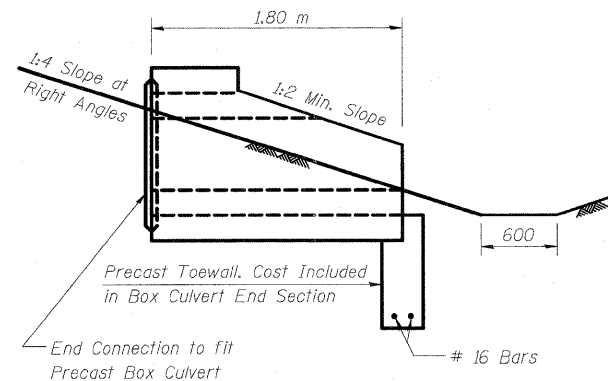

SIDE VIEW

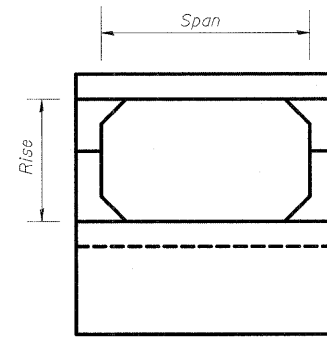

END VIEW

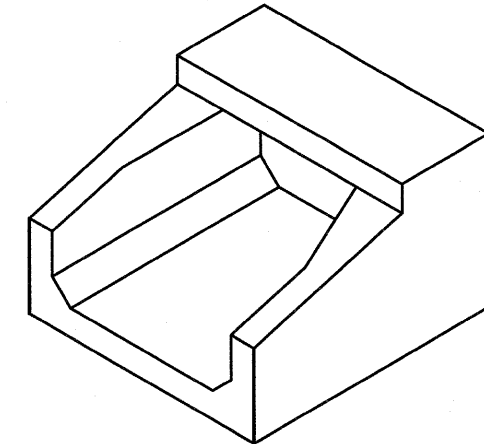

ISOMETRIC VIEW

PRECAST CONCRETE BOX CULVERT END SECTION DETAILS

Box Culvert No.	Span	Rise
1	900	450
4	600	600
8	3000	1650
10	600	450
11	900	600
15	600	450
16	900	450
17	600	600

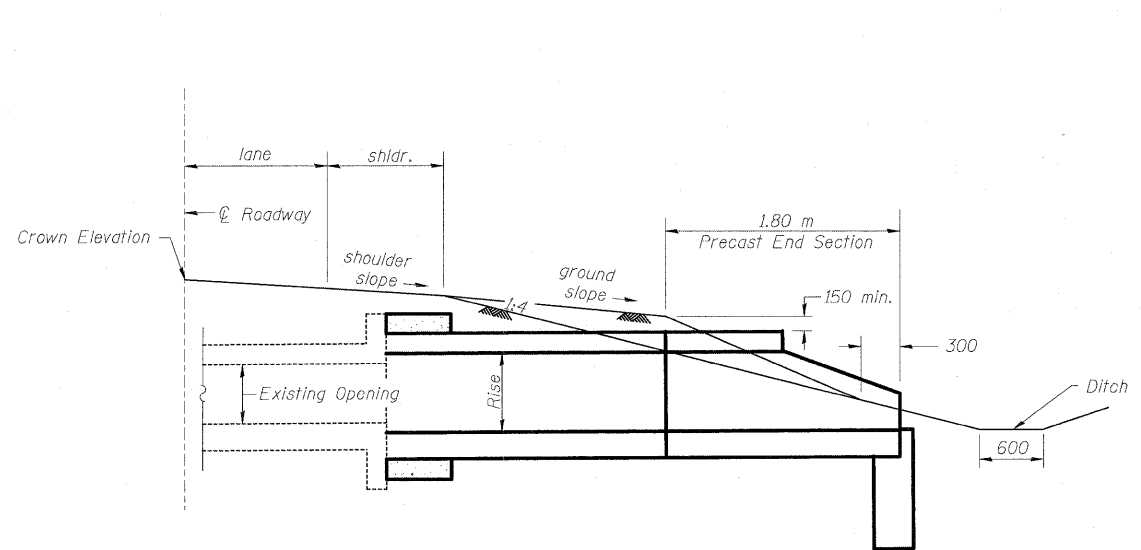

LONGITUDINAL SECTION

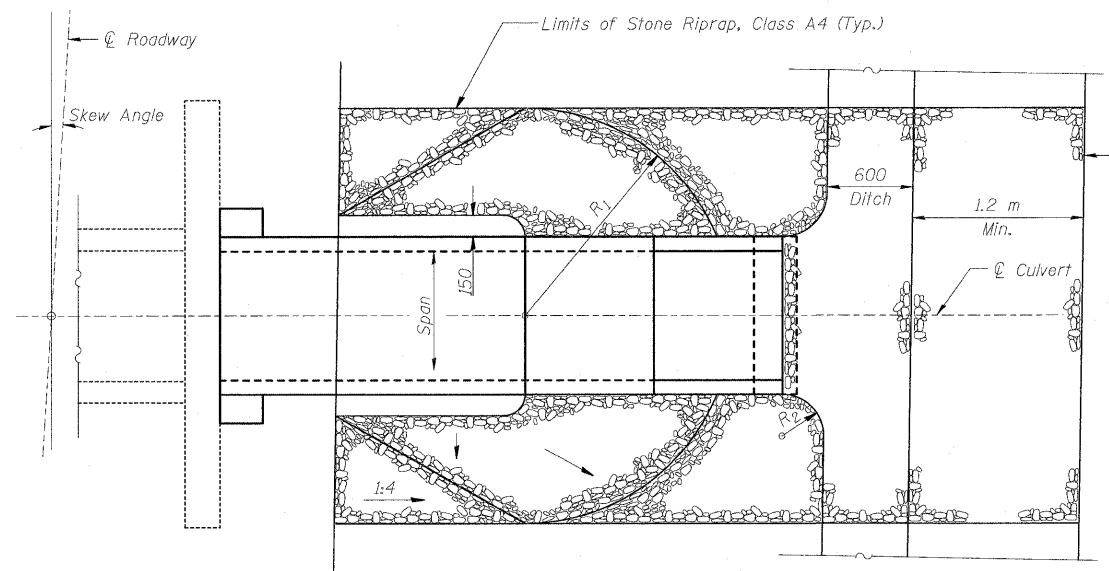

PLAN VIEW

SLOPE TREATMENT DETAILS

GENERAL NOTES

1. Reinforcement for precast box end sections shall conform to specifications for the same size box unit for the specifications specified for that culvert.
2. Reinforcement shall be welded wire fabric conforming to ASTM A-185. Laps, welds and spacing shall conform to ASTM C-789 and AASHTO M-259.

REVISIONS	
NAME	DATE

SHEET S16 OF 19

ILLINOIS DEPARTMENT OF TRANSPORTATION
BOX CULVERT EXTENSIONS
PRECAST END SECTION DETAILS

SCALE NONE DRAWN BY MLB
DATE DECEMBER 10, 2006 CHECKED BY MTH

PLOT DATE = 3/20/2008
FILE NAME = H:\4420\4420.5\Lin_Eng\design_files\12-18-2006\S-16.dgn

LIN NO. 9803

F.A.P. RTE.	SECTION	COUNTY	TOTAL SHEETS	SHEET NO.
781	1YRS, 2ZRS-1	CRAWFORD	378	199
STA.		TO STA.		
FED. ROAD DIST. NO.		ILLINOIS	FED. AID PROJECT	

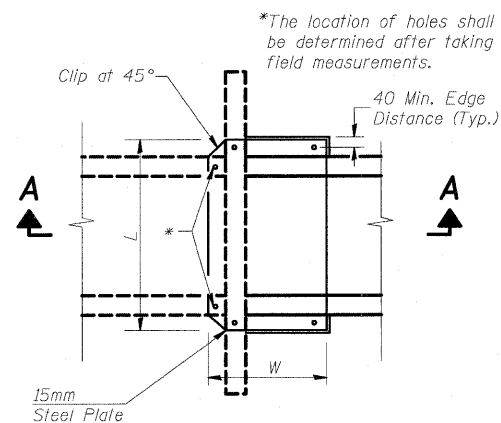

**PLAN
DETAIL OF STEEL PLATE
ATTACHMENT**

Box No.	Location	Size L x W
1	Upstream Collar	1500 x 700 **
4	Downstream Collar	1500 x 700 **

**Contractor to verify dimensions based on actual culvert size provided by the fabricator.

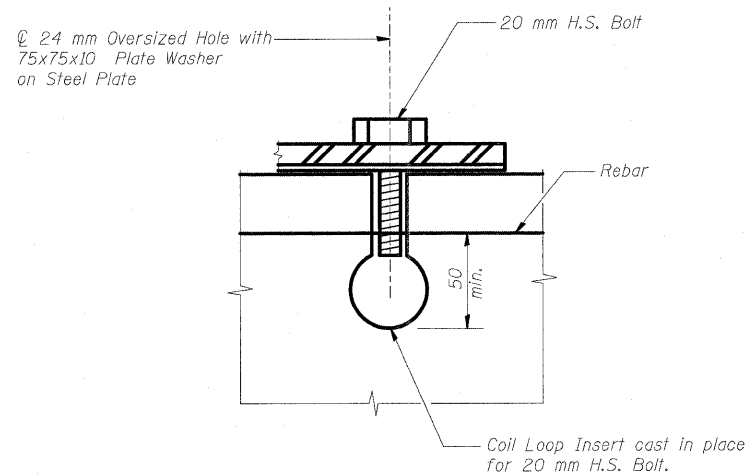

DETAIL A

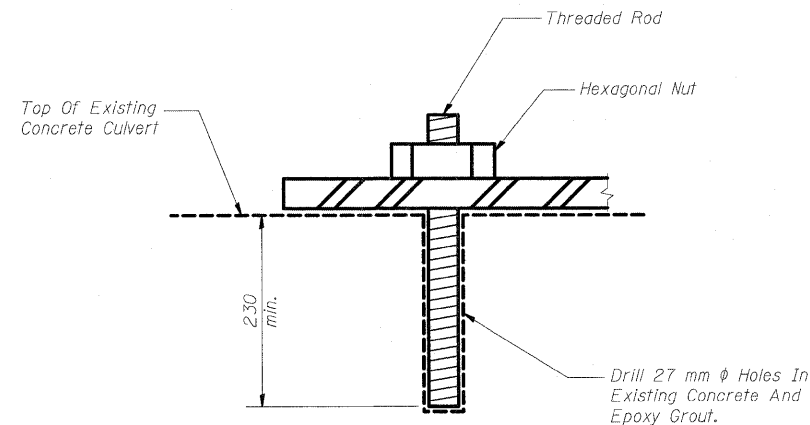

DETAIL B

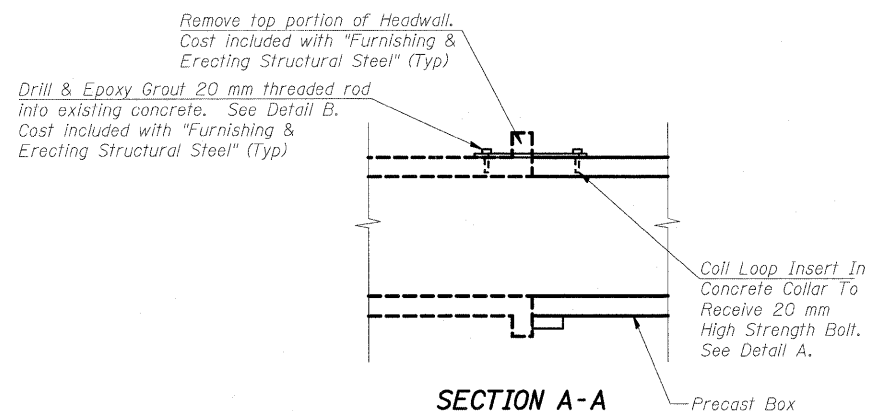

SECTION A-A

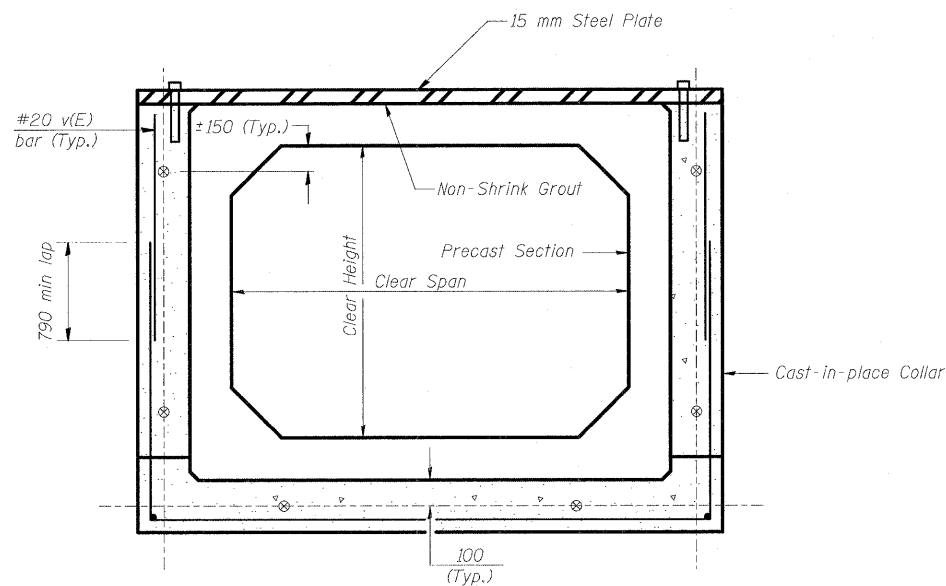

**MODIFIED COLLAR DETAIL WITH
STEEL PLATE AT TOP**

See Sheet S17 of 19 for Collar Details and Reinforcement Bar List.

NOTES

The Steel Plate & Hardware shall be Galvanized in accordance with AASHTO M232, AASHTO M111 and ASTM A385.

REVISIONS		ILLINOIS DEPARTMENT OF TRANSPORTATION BOX CULVERT EXTENSIONS MISCELLANEOUS DETAILS	
NAME	DATE		
SCALE	NONE	DRAWN BY	MLB
DATE	DECEMBER 10, 2006	CHECKED BY	MTH

F.A.P. RTE.	SECTION	COUNTY	TOTAL SHEETS	SHEET NO.
781	1YRS, 2ZRS-1	CRAWFORD	378	200
STA.		TO STA.		
FED. ROAD DIST. NO.		ILLINOIS	FED. AID PROJECT	

Existing Structure: The structure is a single barrel 914 mm x 457 mm box culvert at a skew of 0°34'23" right forward. The culvert has an overall length of 9.59 m. The culvert is to be filled with Controlled Low-Strength Material and abandoned.

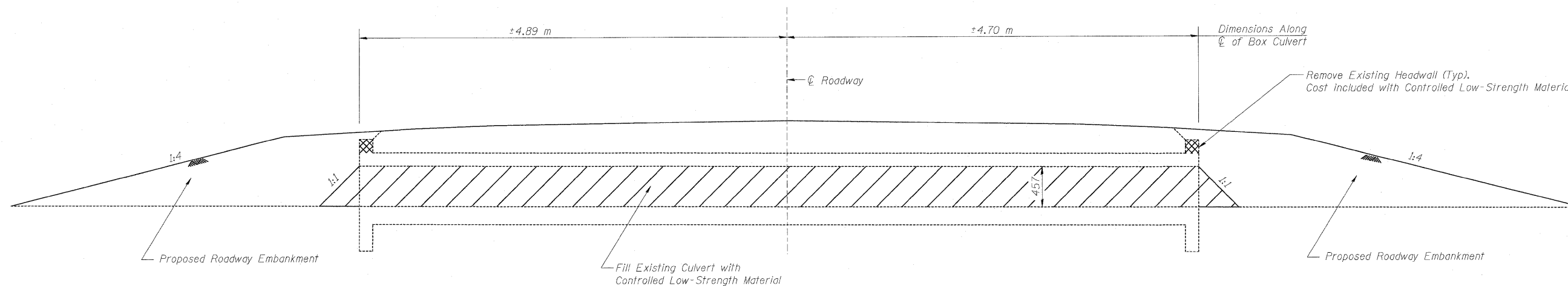

LONGITUDINAL SECTION
(E.C. #101)

Existing Structure: The structure is a single barrel 610 mm x 457 mm box culvert at a skew of 0°12'20" right forward. The culvert has an overall length of 9.64 m. The culvert is to be filled with Controlled Low-Strength Material and abandoned.

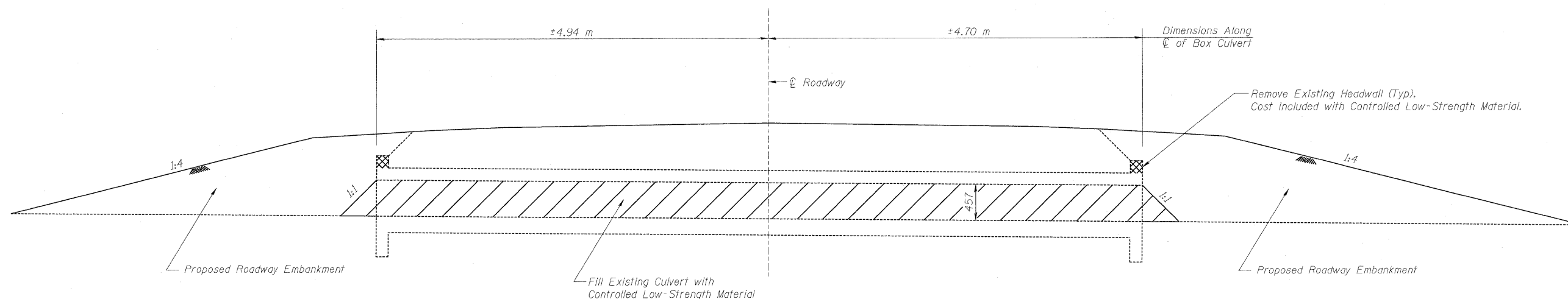

LONGITUDINAL SECTION
(E.C. #105)

*Drilling holes in the top slab may be required for placement of C.L.S.M. Cost included in pay item Controlled Low-Strength Material.

BILL OF MATERIAL - E.C. #101 & E.C. #105

Item	Unit	Total
Controlled Low-Strength Material	cu. m.	7.0

REVISIONS	
NAME	DATE

SHEET S19 OF 19

ILLINOIS DEPARTMENT OF TRANSPORTATION
BOX CULVERT EXTENSIONS
PLUG & FILL DETAILS
E.C. 101 & E.C. 105

SCALE NONE DRAWN BY MLB
DATE DECEMBER 10, 2006 CHECKED BY MTH

PLOT DATE = 3/20/2008
FILE NAME = H:\4420\4420.05 (Lin Eng)\design files\12-18-2006\IS-19.dgn

LIN NO. 9803