

F.A.P. RTE.	SECTION	COUNTY	TOTAL SHEETS	SHEET NO.
781	1YRS, 2ZRS-1	CRAWFORD	378	134
STA.		TO STA.		
FED. ROAD DIST. NO.		ILLINOIS	FED. AID PROJECT	

Notes:

- Junction Box walls shall be constructed of precast or cast-in-place concrete in accordance with Section 602 of the Standard Specifications and Special Provisions.
- Steps shall be required for all Junction Boxes. Steps shall be in accordance with Standard 602401 and Article 602.08 of the Standard Specifications.
- Reinforcement Bars shall conform to the requirements of AASHTO M-31 or M-322, Grade 400.
- All Reinforcement Bars for Junction Boxes shall be epoxy coated, AASHTO M-284.
- Bill of Materials are shown for informational purposes only. Quantities of "Concrete Structures" and "Reinforcement Bars, Epoxy Coated" shall be included in the cost of Providing Junction Boxes. See Special Provisions.
- All dimensions are in millimeters unless otherwise shown.

**BILL OF MATERIALS
JUNCTION BOX NO. 1**

BAR	NO.	SIZE	LENGTH (m)	SHAPE
a ₁ (E)	33	#22	3.350	⌒
a ₃ (E)	33	#16	2.850	—
h(E)	17	#22	1.730	—
h ₉ (E)	15	#22	1.730	—
Concrete Structures			CU M	2.1
Reinforcement Bars, Epoxy Coated			KG	910

Cut a₁(E), a₃(E), h(E) and h₉(E) bars in the field to miss the MH opening in the top slab.

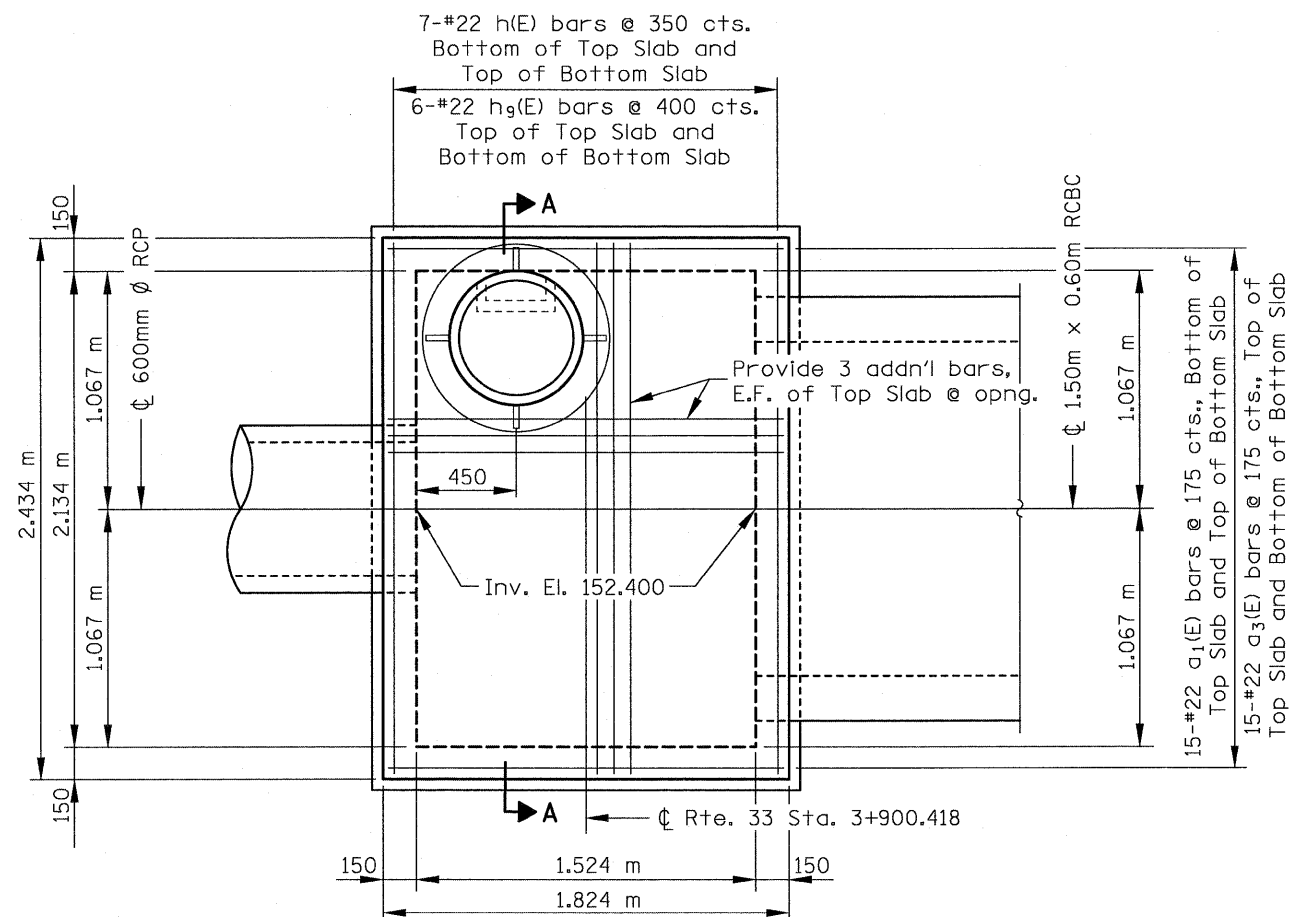
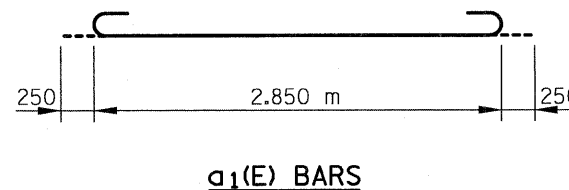

PLAN - JUNCTION BOX NO. 1

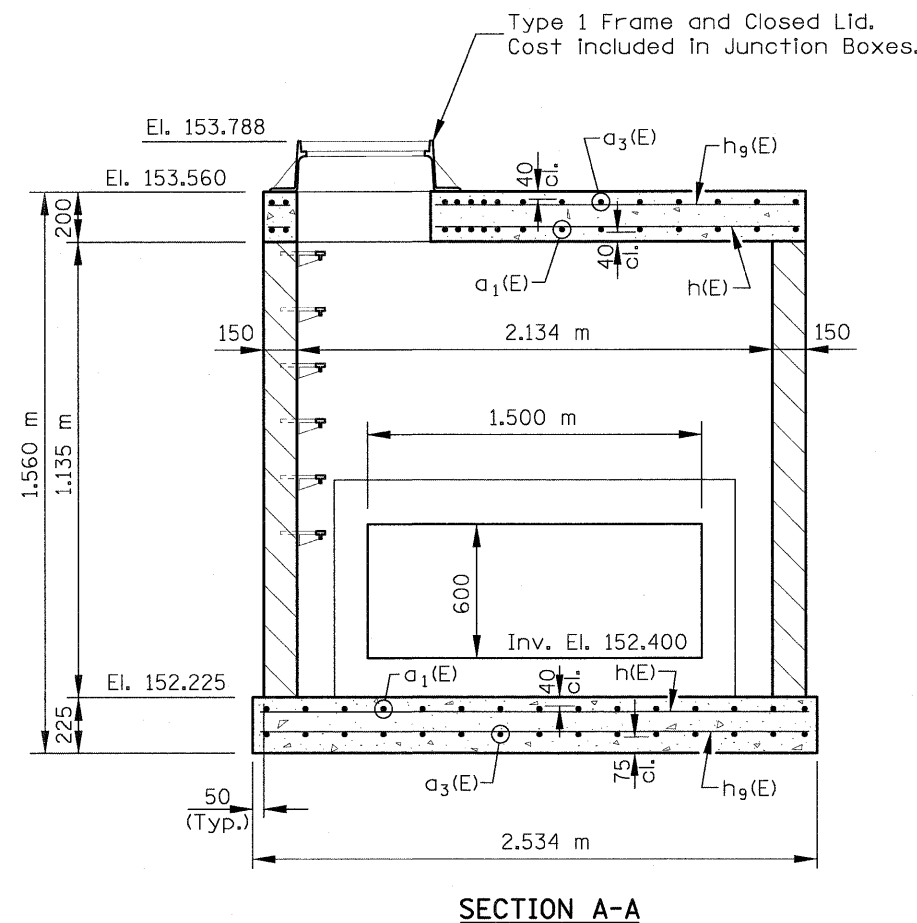

REVISIONS

NAME	DATE

ILLINOIS DEPARTMENT OF TRANSPORTATION

**STORM SEWER DETAILS
JUNCTION BOX NO. 1**

SCALE NO SCALE DRAWN BY KHL
 DATE MARCH 20, 2008 CHECKED BY GME