

F.A.P. RTE.	SECTION	COUNTY	TOTAL SHEETS	SHEET NO.
781	1YRS, 2ZRS-1	CRAWFORD	378	132
STA.		TO STA.		
FED. ROAD DIST. NO.		ILLINOIS	FED. AID PROJECT	

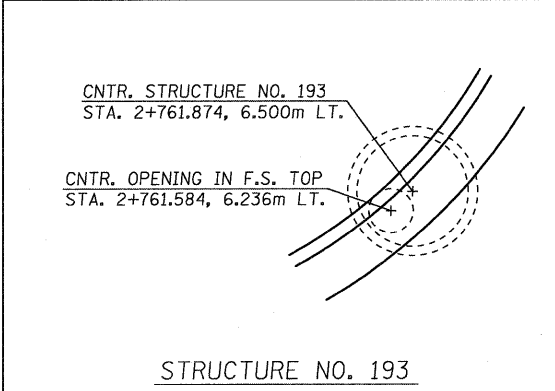

STRUCTURE NO. 193

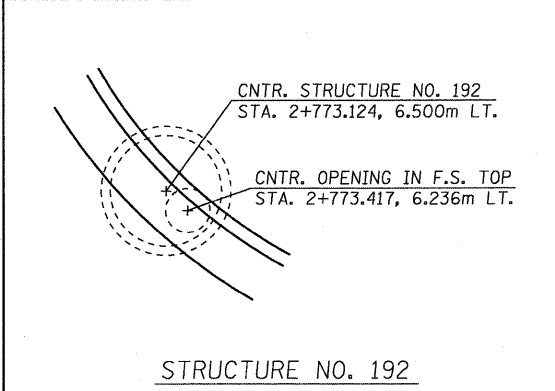

STRUCTURE NO. 192

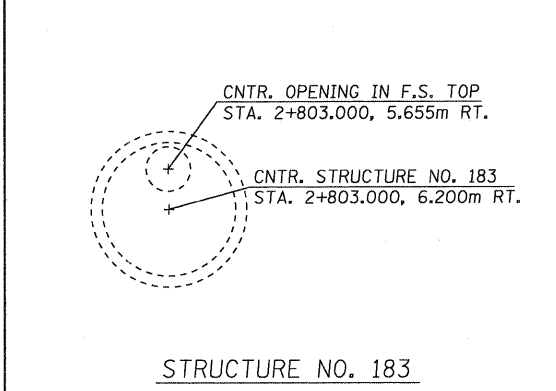

STRUCTURE NO. 183

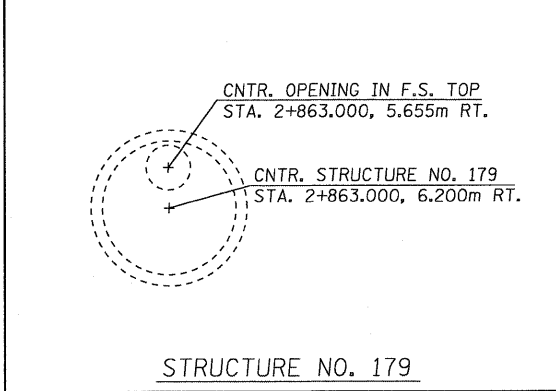

STRUCTURE NO. 179

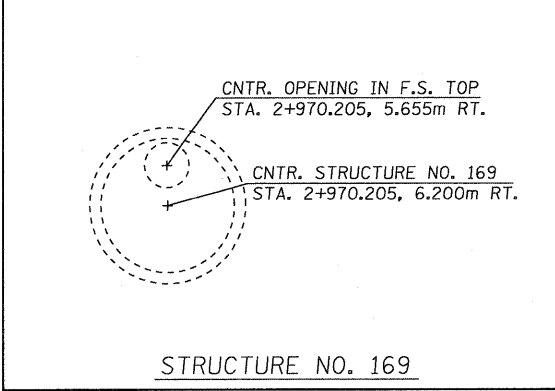

STRUCTURE NO. 169

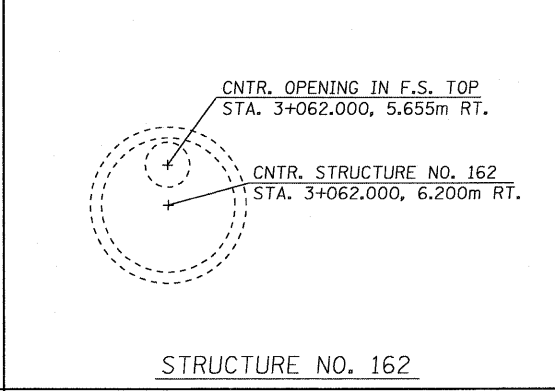

STRUCTURE NO. 162

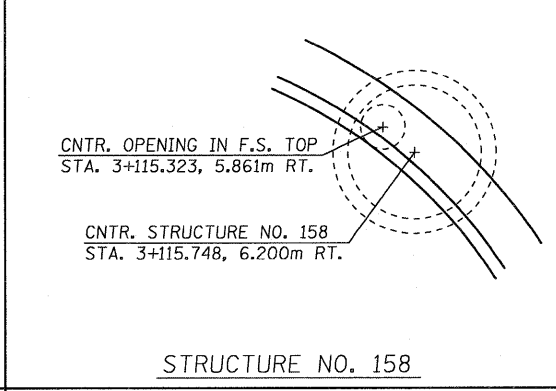

STRUCTURE NO. 158

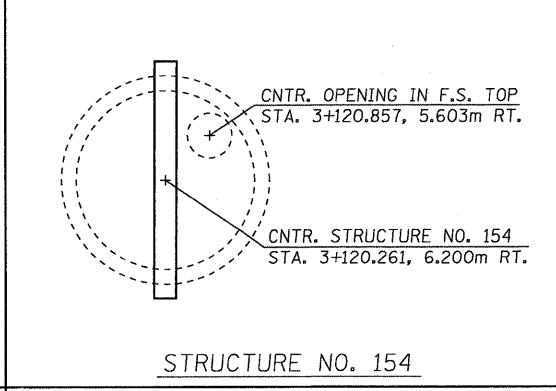

STRUCTURE NO. 154

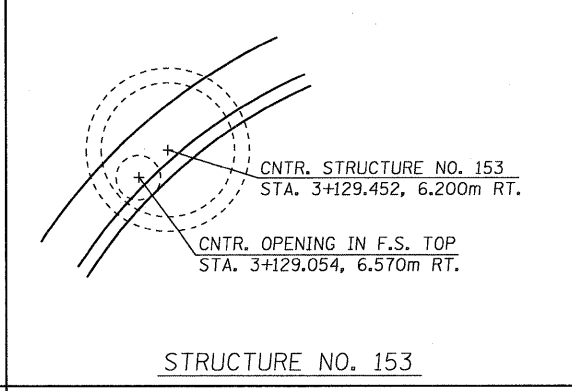

STRUCTURE NO. 153

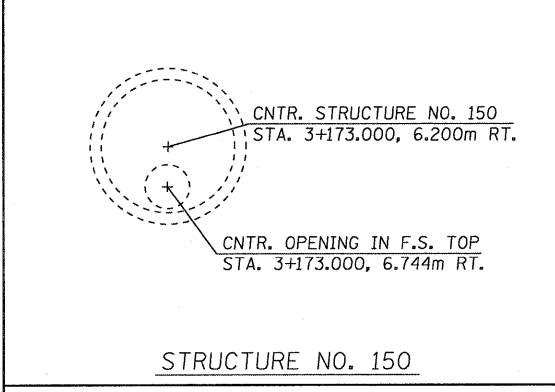

STRUCTURE NO. 150

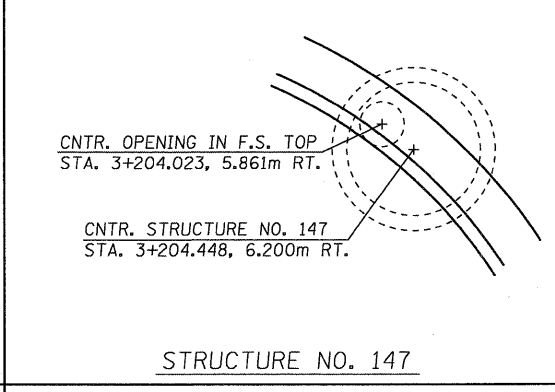

STRUCTURE NO. 147

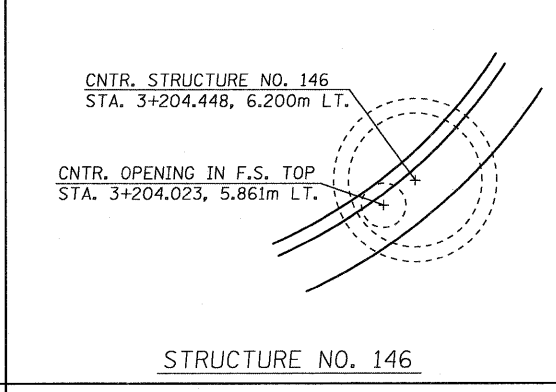

STRUCTURE NO. 146

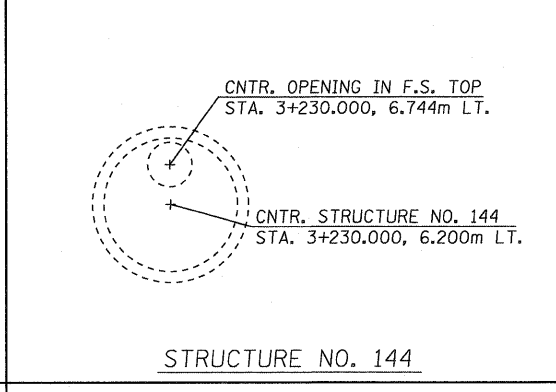

STRUCTURE NO. 144

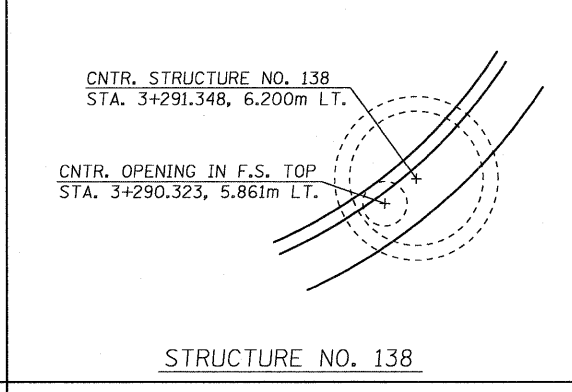

STRUCTURE NO. 138

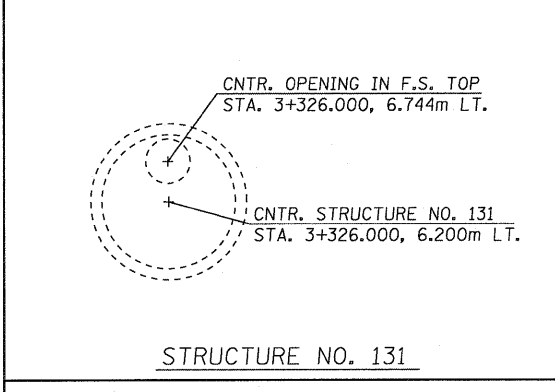

STRUCTURE NO. 131

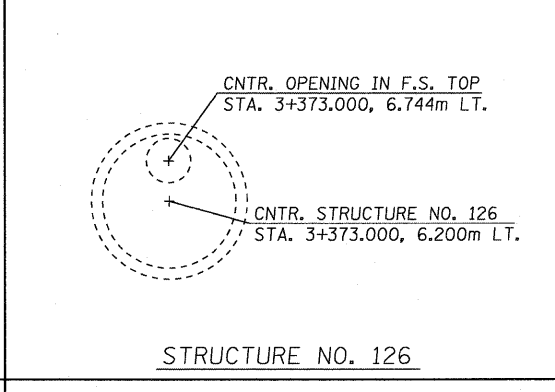

STRUCTURE NO. 126

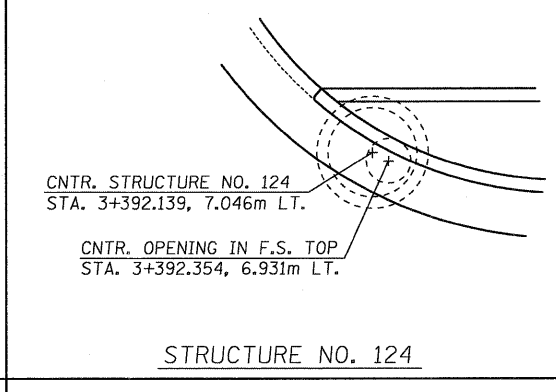

STRUCTURE NO. 124

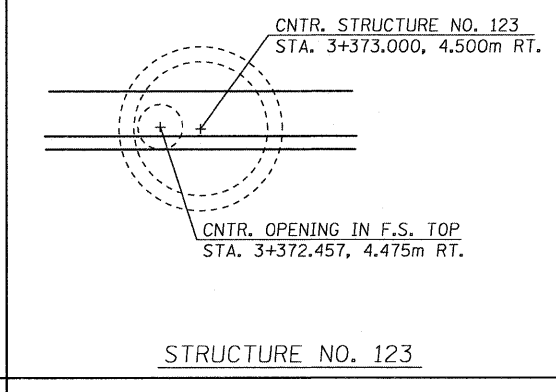

STRUCTURE NO. 123

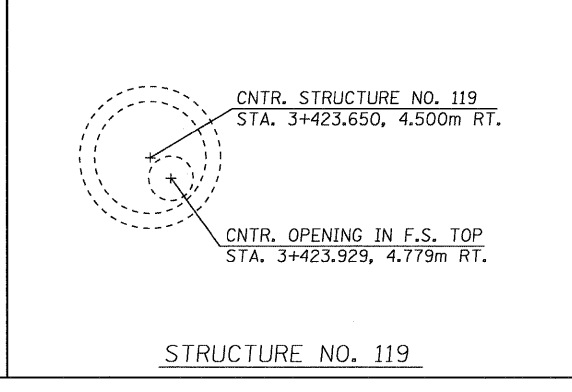

STRUCTURE NO. 119

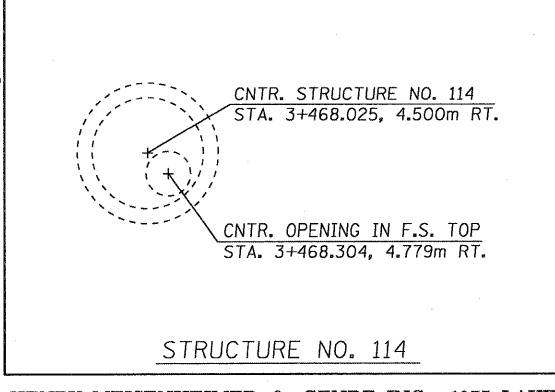

STRUCTURE NO. 114

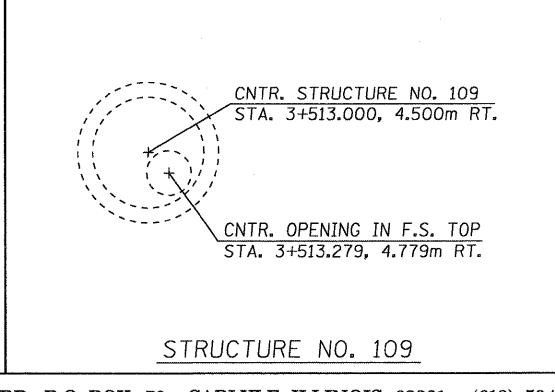

STRUCTURE NO. 109

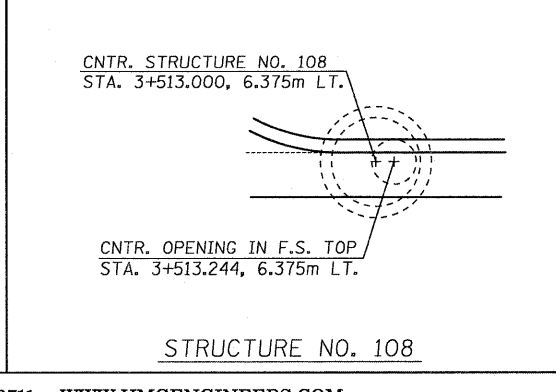

STRUCTURE NO. 108

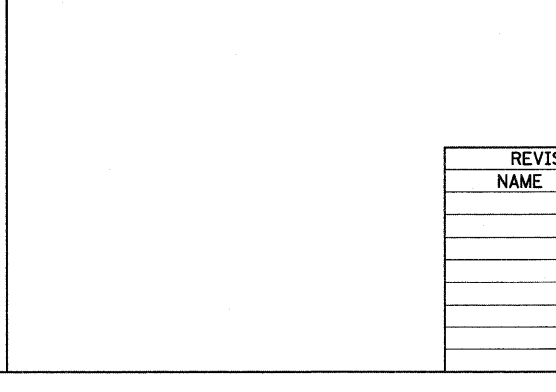

REVISIONS	
NAME	DATE

ILLINOIS DEPARTMENT OF TRANSPORTATION

**STORM SEWER DETAILS**

SCALE NO SCALE  
DATE MARCH 20, 2008

DRAWN BY EDW  
CHECKED BY RGH

PLOT DATE = 3/20/2008  
FILE NAME = H:\1420\170132.dwg

H. M. & G. NO. 4420