

ELEVATION

SECTION A-A

	0.5 Sp. I	
I_s	(in ⁴) 4080	
$I_c(n)$	(in ⁴) 11393	
$I_c(3n)$	(in ⁴) 8346	
S_s	(in ³) 299	
$S_c(n)$	(in ³) 450	
$S_c(3n)$	(in ³) 404	
ρ	(k/')	0.763
$M \rho$	(k)	296
$s \rho$	(k/')	0.414
$M_s \rho$	(k)	160
$M \ddagger$	(k)	405
M_{Imp}	(k)	112
$\frac{2}{3} [M \ddagger + M_{Imp}]$	(k)	863
M_a	(k)	1714
M_u	(k)	2276
$f_s \rho_{non-comp}$	(ksi)	11.9
$f_s \rho_{comp}$	(ksi)	4.8
$f_s \frac{2}{3} [M \ddagger + M_{Imp}]$	(ksi)	23.0
f_s (Overload)	(ksi)	39.7
VR	(k)	42.9

I_s, S_s : Non-composite moment of inertia and section modulus of the steel section used for computing f_s (Total and Overload) due to non-composite dead loads (in⁴ and in³).

$I_c(n), S_c(n)$: Composite moment of inertia and section modulus of the steel and deck based upon the modular ratio, "n", used for computing f_s (Total and Overload) due to short-term composite live loads (in⁴ and in³).

$I_c(3n), S_c(3n)$: Composite moment of inertia and section modulus of the steel and deck based upon 3 times the modular ratio, "3n", used for computing f_s (Total and Overload) due to long-term composite (superimposed) dead loads (in⁴ and in³).

ρ : Un-factored non-composite dead load (kips/ft.).

$M \rho$: Un-factored moment due to non-composite dead load (kip-ft.).

$s \rho$: Un-factored long-term composite (superimposed) dead load (kips/ft.).

$M_s \rho$: Un-factored moment due to long-term composite (superimposed) dead load (kip-ft.).

$M \ddagger$: Un-factored live load moment (kip-ft.).

M_{Imp} : Un-factored moment due to impact (kip-ft.).

M_a : Factored design moment (kip-ft.).

$1.3 [M \rho + M_s \rho + \frac{5}{3} (M \ddagger + M_{Imp})]$

M_u : Compact composite moment capacity according to AASHTO LFD 10.50.1.1.

f_s (Overload): Sum of stresses as computed from the moments below (ksi).

$M \rho + M_s \rho + \frac{5}{3} (M \ddagger + M_{Imp})$

VR: Maximum impact horizontal shear range within the composite portion of the span for stud shear connector design (kips).

	Abut.
$R \rho$	(k) 32.8
$R \ddagger$	(k) 33.3
Imp.	(k) 9.2
R_{Total}	(k) 75.3

* Compact section

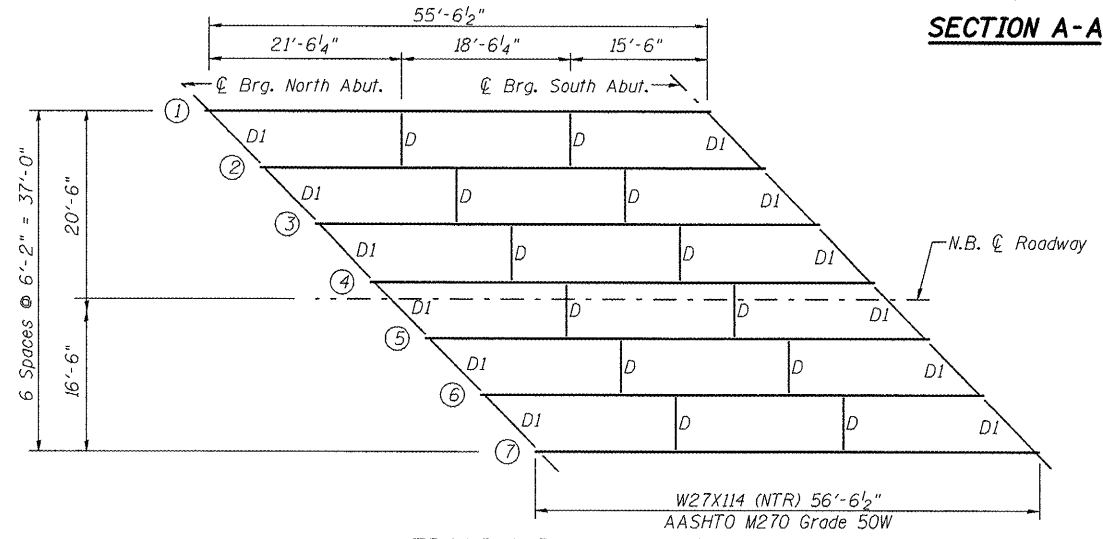

FRAMING PLAN S.N. 068-0038

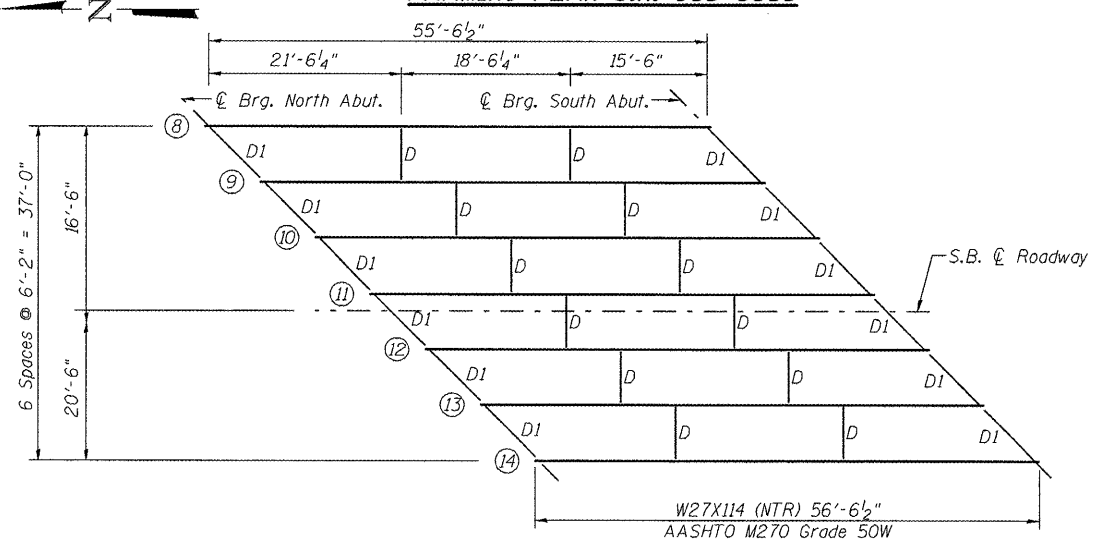

FRAMING PLAN S.N. 068-0039

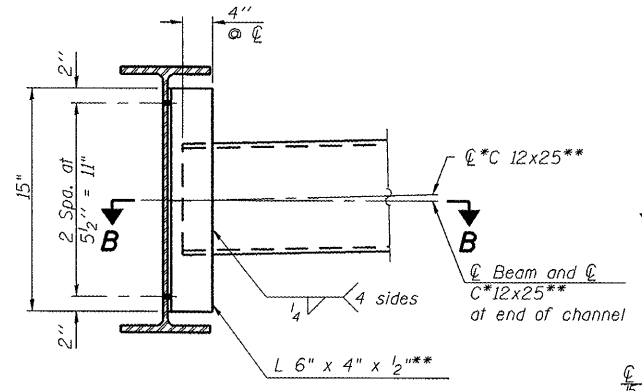

INTERIOR DIAPHRAGM-D
(24 Required)

Note: Two hardened washers required for each set of oversized holes.

* Alternate C 12x30 Channels are permitted to facilitate material acquisition. Calculated weight of structural steel is based on the lighter section.

** AASHTO M270 Grade 50W

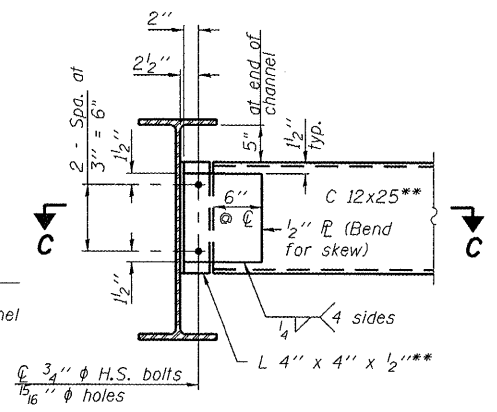

END DIAPHRAGM-D1
(24 Required)

Note: Two hardened washers required for each set of oversized holes.

** AASHTO M270 Grade 50W

	N. Abut.	S. Abut.
Beam 1	630.00	629.92
Beam 2	630.12	630.04
Beam 3	630.22	630.14
Beam 4	630.31	630.23
Beam 5	630.26	630.18
Beam 6	630.16	630.08
Beam 7	630.04	629.96
Beam 8	629.94	629.86
Beam 9	630.05	629.97
Beam 10	630.13	630.05
Beam 11	630.16	630.08
Beam 12	630.06	629.98
Beam 13	629.94	629.86
Beam 14	629.81	629.73

TOP OF BEAM ELEVATIONS
(For Fabrication use Only)

Note: All cross frames or diaphragms shall be installed as steel is erected and secured with erection pins and bolts except as otherwise noted. Individual cross frames or diaphragms at supports may be temporarily disconnected to install bearing anchor bolts.

Load carrying components designated "NTR" shall conform to the Supplemental Requirements for Notch Toughness, Zone 2.

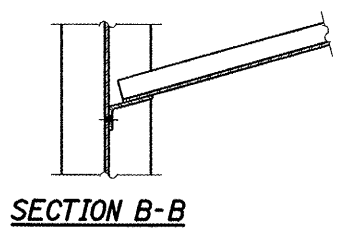

SECTION B-B

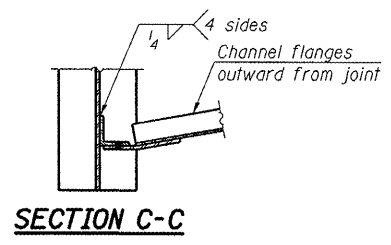

SECTION C-C

ILLINOIS DEPARTMENT OF TRANSPORTATION

FRAMING PLAN & STEEL DETAILS
I 55 OVER MACOUPIN CREEK
F.A.I. ROUTE 55 - SEC. (68-4)F
MONTGOMERY COUNTY
STATION 1066+03.18
STRUCTURE NO. 068-0038 N.B.
STRUCTURE NO. 068-0039 S.B.

DATE: 04-08
REVISED:

DRAWN BY: MLO
CHECKED BY: PBB