

F.A.
RTE.
STA.

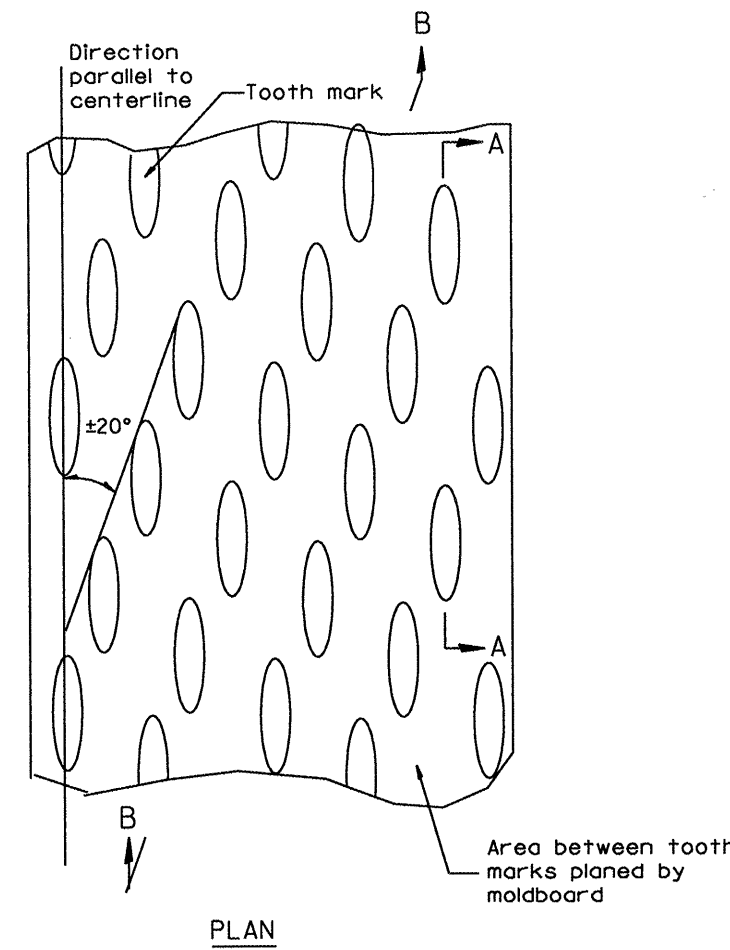

General notes:

1. Coldmilling shall consist of two processes: Cutting with carbide teeth mounted on a rotating drum, and planing with a moldboard mounted immediately behind the cutting drum.
2. Other similar patterns will be acceptable if they consist of a smooth, flat, planed surface interspersed with a pattern of discontinuous longitudinal striations.

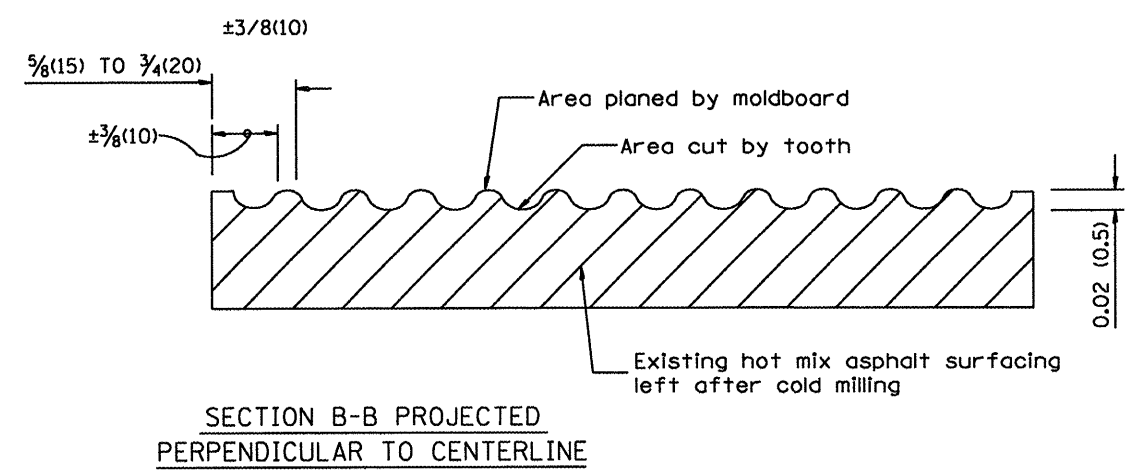
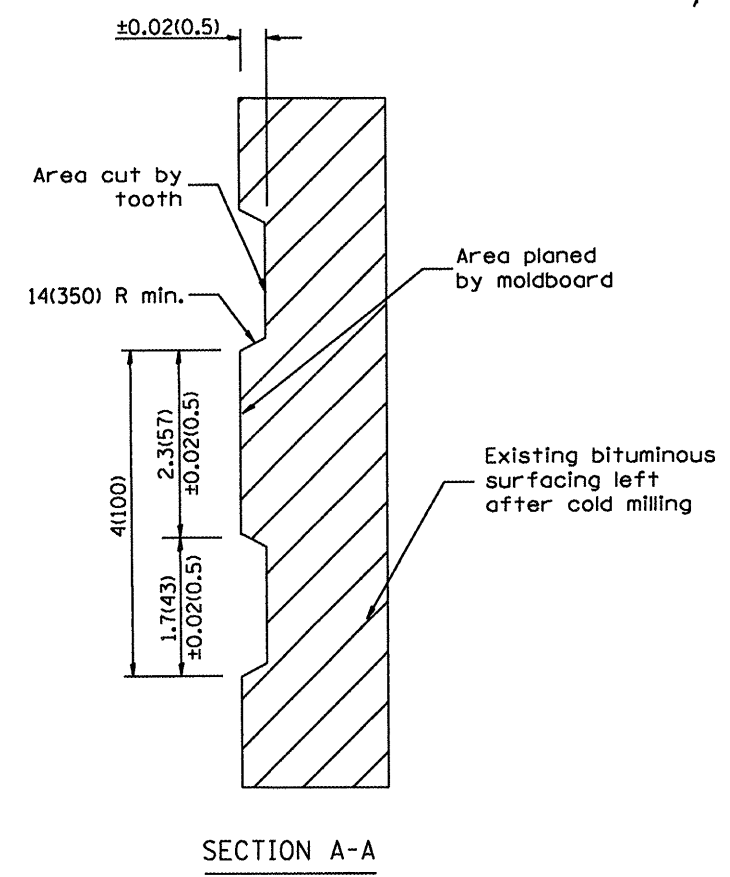

All dimensions are in inches (millimeters) unless otherwise noted.

DATE	REVISIONS	BY
1-1-97	RENUM. C-104.01, NEW REVISION BOX	T. P.
4-20-98	REMOVED MILLING DETAIL FROM STD.	J. A.
9-08-98	CORRECT NOTE LEADER PLACEMENT	R. W.
10-16-06	REVISED TO 2007 SPEC.	M.A.

ILLINOIS DEPARTMENT OF TRANSPORTATION				
DISTRICT CADD STANDARD				
HOT MIX ASPHALT SURFACE REMOVAL (COLD MILLING)				
CADD STD NO. 440001-D4				
SCALE: NOT DRAWN TO SCALE		DRAWN BY CADD		
DATE		CHECKED BY		
F.A. RTE.	SECTION	COUNTY	TOTAL SHEETS	SHEET NO.
649	11G18CSRS-1J3RS-2R5A12Z2RS-2	MARSHALL	15	15
FED. ROAD DIST. NO.		ILLINOIS FED. AID PROJECT		

FILE NAME =	USER NAME = longsr	DESIGNED -	REVISD -
S:\GEN\DRFT\STD&PLNS\Squad\68560 IL2	N Leon\plans.dgn	DRAWN -	REVISD -
PLOT SCALE = 206.8858 * / IN.		CHECKED -	REVISD -
PLOT DATE = 7/24/2008		DATE -	REVISD -

STATE OF ILLINOIS
DEPARTMENT OF TRANSPORTATION

440001-D4
SCALE: SHEET NO. OF SHEETS STA. TO STA.