

ILL. 26

STA. 7+08 to 174+31
 STA. 176+21 to 315+85
 ** Sta. 7+28 to 14+78

* MATCH EXISTING IN SUPERELEVATED LOCATIONS

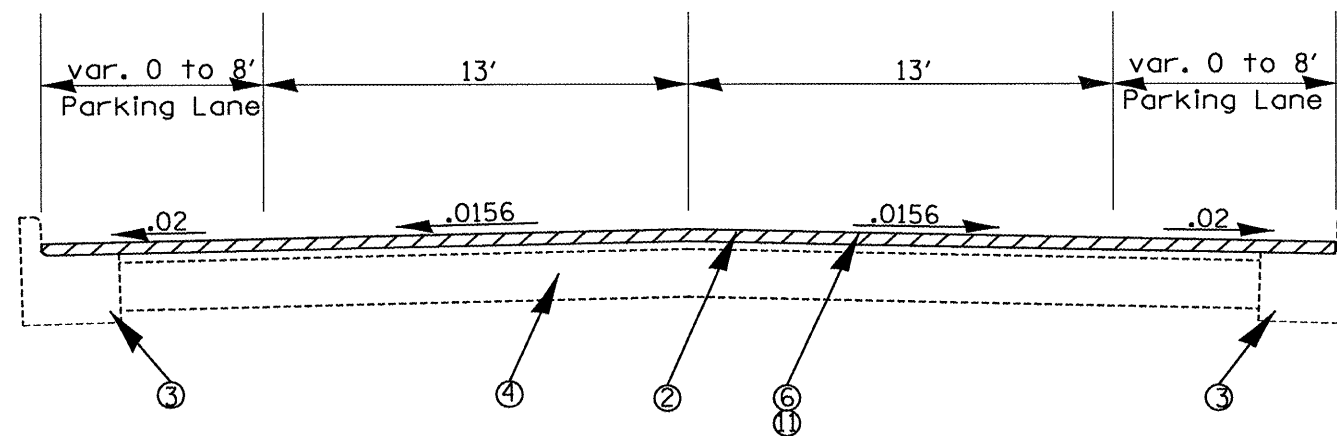

ILL. 26

STA. 315+85 to 333+10 bk
 STA. 90+00 to 100+75 bk
 STA. 68+45 to 85+20 (south of IL 17)

LEGEND

- ① EXISTING PAVEMENT
- ② EXISTING HMA OVERLAY 7" +/-
- ③ EXISTING CCC&G
- ④ EXISTING AGGREGATE BASE
- ⑤ PROPOSED HMA SURFACE REMOVAL 3/4"
- ⑥ PROPOSED HMA SURFACE REMOVAL 2"
- ⑦ PROPOSED HMA SURFACE REMOVAL 4"
- ⑧ PROPOSED HMA SURFACE CSE 1 1/2"
- ⑨ PROPOSED POLYMERIZED LEVELING BINDER 3/4"
- ⑩ PROPOSED HMA BINDER CSE 3 1/4"
- ⑪ PROPOSED HMA SURFACE CSE 2"
- ⑫ PROPOSED AGGREGATE SHOULDERS TYPE B

FILE NAME =	USER NAME = longar	DESIGNED -	REVISED -	STATE OF ILLINOIS DEPARTMENT OF TRANSPORTATION	ILL. 26 TYPICAL SECTIONS	F.A.P. RTE.	SECTION	COUNTY	TOTAL SHEETS	SHEET NO.	
S:\GEN\DRIFT\STD&PLNS\Squad\68560 IL2	N Leon\plens.dgn	DRAWN -	REVISED -			649	HQ.10CSRS-1,3RS-2,RS4(22,2RS-2	MARSHALL	15	5	
	PLOT SCALE = 206.8058 ' / IN.	CHECKED -	REVISED -			CONTRACT NO. 68560					
	PLOT DATE = 10/7/2008	DATE -	REVISED -			FED. ROAD DIST. NO. ILLINOIS FED. AID PROJECT					