

General notes:

1. Coldmilling shall consist of two processes: Cutting with carbide teeth mounted on a rotating drum, and planing with a moldboard mounted immediately behind the cutting drum.
2. Other similar patterns will be acceptable if they consist of a smooth, flat, planed surface interspersed with a pattern of discontinuous longitudinal striations.

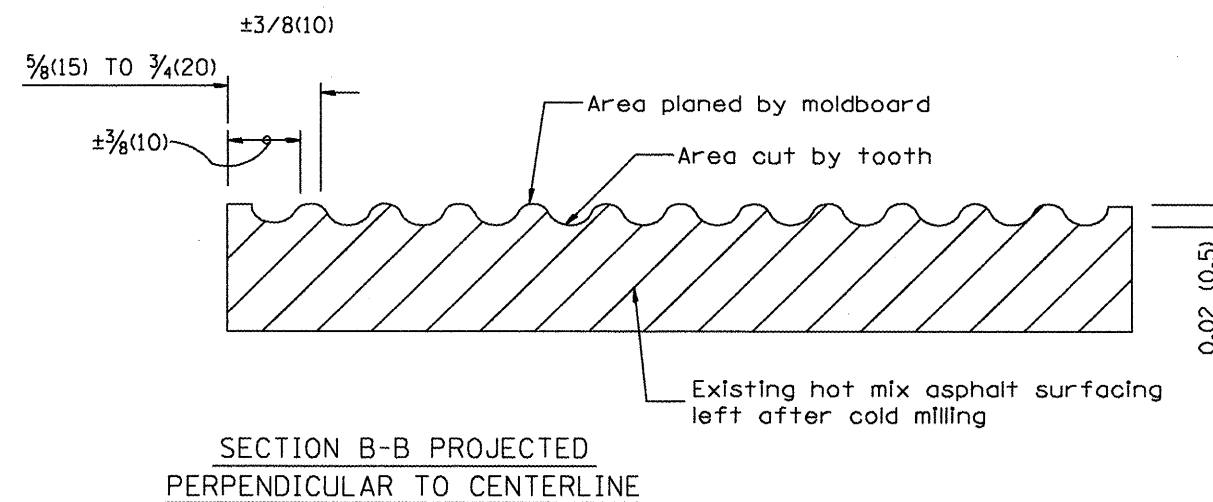
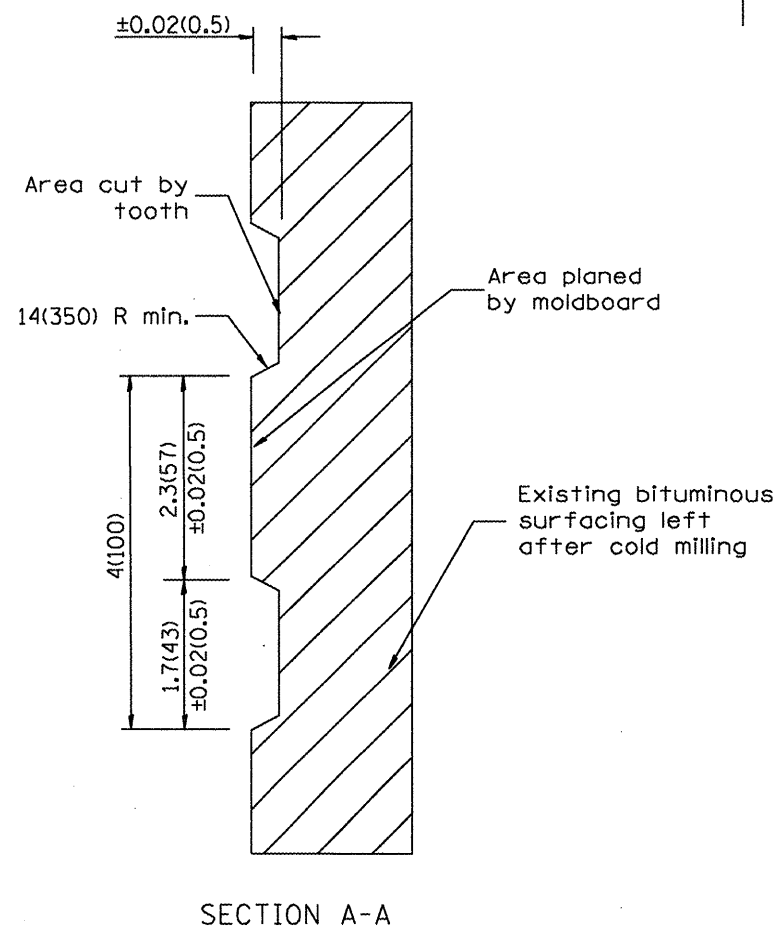

All dimensions are in inches (millimeters) unless otherwise noted.

01-01-97	RENUM. C-104.01, NEW REVISION BOX	T.P.
04-20-98	REMOVED MILLING DETAIL FROM STANDARD	J.A.
09-08-98	CORRECT NOTE LEADER PLACEMENT	R.W.
10-16-06	REVISED TO 2007 SPEC.	M.A.

STATE OF ILLINOIS  
DEPARTMENT OF TRANSPORTATION

HOT MIX ASPHALT SURFACE REMOVAL (COLD MILLING)

NOT TO SCALE

CADD STD. 440001-D4

F.A.U. RTE.	SECTION	COUNTY	TOTAL SHEETS	SHEET NO.
6578	(1)-RIRS, (1)-VSBLE:	PEORIA	172	132
FED. ROAD DIST. NO. ILLINOIS FED. AID PROJECT			CONTRACT NO. 68092	