

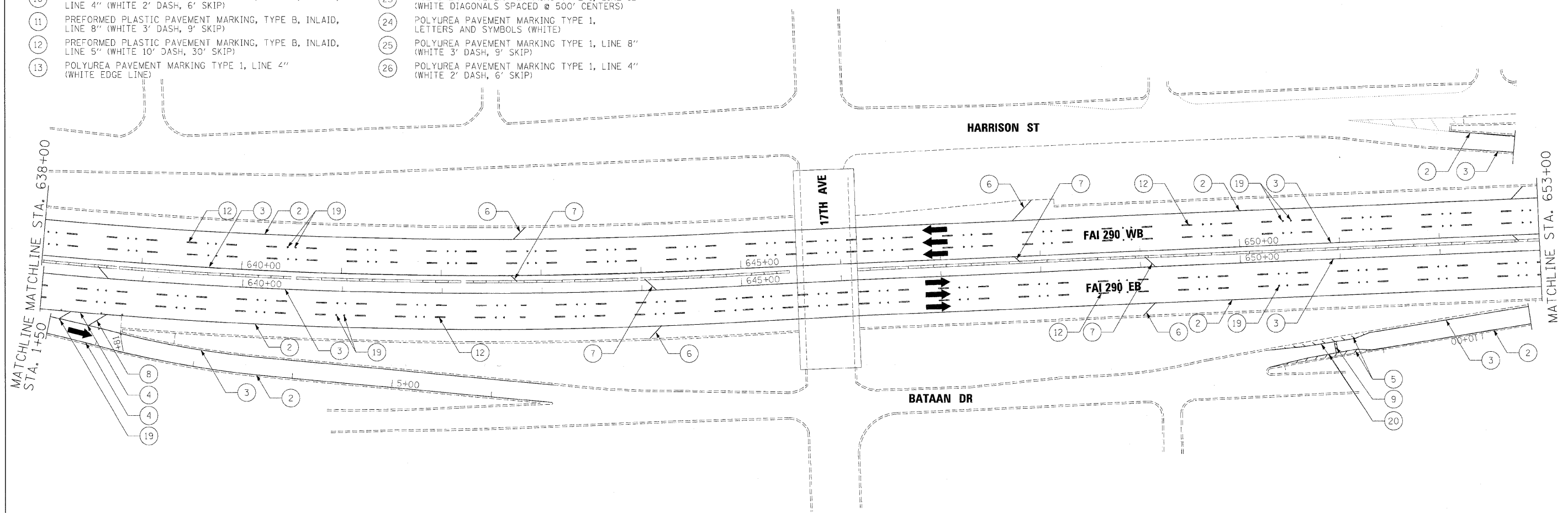

LEGEND

- | | |
|--|--|
| <ul style="list-style-type: none"> ① THERMOPLASTIC PAVEMENT MARKING - LETTERS AND SYMBOLS (WHITE) ② THERMOPLASTIC PAVEMENT MARKING - LINE 4" (WHITE EDGE LINE) ③ THERMOPLASTIC PAVEMENT MARKING - LINE 4" (YELLOW EDGE LINE) ④ THERMOPLASTIC PAVEMENT MARKING - LINE 8" (WHITE EDGE LINE) ⑤ THERMOPLASTIC PAVEMENT MARKING - LINE 8" (WHITE DIAGONALS SPACED @ 10' CENTERS) ⑥ THERMOPLASTIC PAVEMENT MARKING - LINE 12" (WHITE DIAGONALS SPACED @ 500' CENTERS) ⑦ THERMOPLASTIC PAVEMENT MARKING - LINE 12" (YELLOW DIAGONALS SPACED @ 500' CENTERS) ⑧ THERMOPLASTIC PAVEMENT MARKING - LINE 12" (WHITE GORE DIAGONALS SPACED @ 30' CENTERS) ⑨ THERMOPLASTIC PAVEMENT MARKING - LINE 24" (WHITE) ⑩ PREFORMED PLASTIC PAVEMENT MARKING, TYPE B, INLAID, LINE 4" (WHITE 2' DASH, 6' SKIP) ⑪ PREFORMED PLASTIC PAVEMENT MARKING, TYPE B, INLAID, LINE 8" (WHITE 3' DASH, 9' SKIP) ⑫ PREFORMED PLASTIC PAVEMENT MARKING, TYPE B, INLAID, LINE 5" (WHITE 10' DASH, 30' SKIP) ⑬ POLYUREA PAVEMENT MARKING TYPE 1, LINE 4" (WHITE EDGE LINE) | <ul style="list-style-type: none"> ⑭ POLYUREA PAVEMENT MARKING TYPE 1, LINE 4" (YELLOW EDGE LINE) ⑮ POLYUREA PAVEMENT MARKING TYPE 1, LINE 8" (WHITE EDGE LINE) ⑯ POLYUREA PAVEMENT MARKING TYPE 1, LINE 5" (WHITE 10' DASH, 30' SKIP) ⑰ POLYUREA PAVEMENT MARKING TYPE 1, LINE 12" (WHITE GORE DIAGONALS SPACED @ 30' CENTERS) ⑱ RAISED REFLECTIVE PAVEMENT MARKER (1-WAY YELLOW / OPAQUE) ⑲ RAISED REFLECTIVE PAVEMENT MARKER (1-WAY CRYSTAL / OPAQUE) ⑳ THERMOPLASTIC PAVEMENT MARKING - LINE 12" (WHITE EDGE LINE) ㉑ THERMOPLASTIC PAVEMENT MARKING - LINE 6" (WHITE THRU LANE LINE) ㉒ POLYUREA PAVEMENT MARKING TYPE 1, LINE 12" (YELLOW DIAGONALS SPACED @ 500' CENTERS) ㉓ POLYUREA PAVEMENT MARKING TYPE 1, LINE 12" (WHITE DIAGONALS SPACED @ 500' CENTERS) ㉔ POLYUREA PAVEMENT MARKING TYPE 1, LETTERS AND SYMBOLS (WHITE) ㉕ POLYUREA PAVEMENT MARKING TYPE 1, LINE 8" (WHITE 3' DASH, 9' SKIP) ㉖ POLYUREA PAVEMENT MARKING TYPE 1, LINE 4" (WHITE 2' DASH, 6' SKIP) |
|--|--|



- NOTE:**
1. SEE IDOT DISTRICT 1 STANDARD TC-12 "MULTI-LANE FREEWAY PAVEMENT MARKING DETAILS" FOR PLACEMENT AND TYPE OF RAISED REFLECTIVE PAVEMENT MARKERS.
 2. FOR PROPOSED PAVEMENT MARKINGS IN THE PCC SECTIONS USE POLYUREA PAVEMENT MARKINGS ACCORDING TO STANDARD TC-12.
 3. REFER TO ROADWAY PLANS FOR LIMITS OF RESURFACING.

FILE NAME =	DESIGNED - AJP	REVISED -
...prp\in_abc\c2\290_pvm\mkg_17.dgn	DRAWN - TMB	REVISED -
USER NAME = tblank	CHECKED - JMM	REVISED -
PLDT DATE = 12/16/2009	DATE - 10/16/09	REVISED -

benesch

**STATE OF ILLINOIS
DEPARTMENT OF TRANSPORTATION**

**PAVEMENT MARKING PLANS
STA 638+00 TO STA 653+00**

SCALE: 1"=50' SHEET NO. 11 OF 31 SHEETS STA. TO STA.

F.A.T. RITE:	SECTION	COUNTY	TOTAL SHEETS	SHEET NO.
290	(3031.1, ETC., 3838)RS-5	COOK	298	201
FED. ROAD DIST. NO. [ILLINOIS] FED. AID PROJECT			CONTRACT NO. 60652	

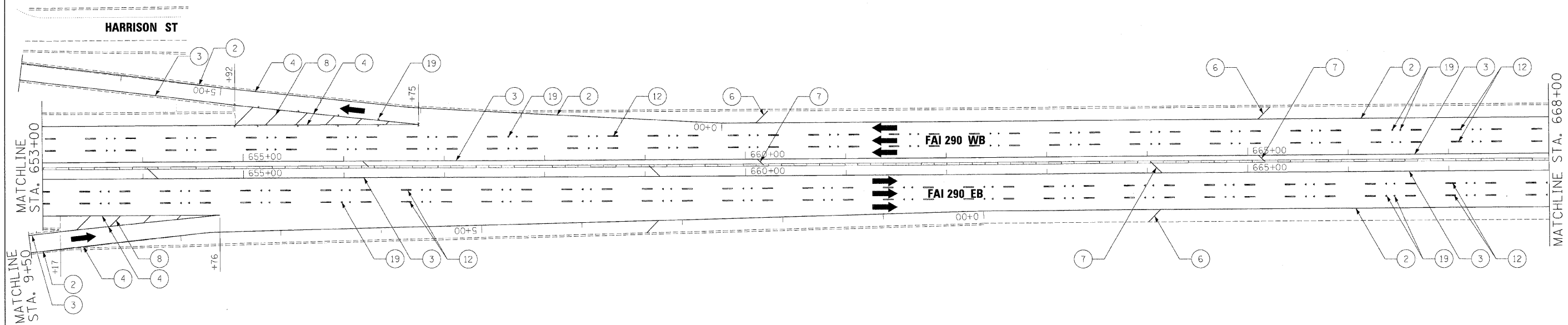

LEGEND

- | | |
|--|--|
| <ul style="list-style-type: none"> ① THERMOPLASTIC PAVEMENT MARKING - LETTERS AND SYMBOLS (WHITE) ② THERMOPLASTIC PAVEMENT MARKING - LINE 4" (WHITE EDGE LINE) ③ THERMOPLASTIC PAVEMENT MARKING - LINE 4" (YELLOW EDGE LINE) ④ THERMOPLASTIC PAVEMENT MARKING - LINE 8" (WHITE EDGE LINE) ⑤ THERMOPLASTIC PAVEMENT MARKING - LINE 8" (WHITE DIAGONALS SPACED @ 10' CENTERS) ⑥ THERMOPLASTIC PAVEMENT MARKING - LINE 12" (WHITE DIAGONALS SPACED @ 500' CENTERS) ⑦ THERMOPLASTIC PAVEMENT MARKING - LINE 12" (YELLOW DIAGONALS SPACED @ 500' CENTERS) ⑧ THERMOPLASTIC PAVEMENT MARKING - LINE 12" (WHITE GORE DIAGONALS SPACED @ 30' CENTERS) ⑨ THERMOPLASTIC PAVEMENT MARKING - LINE 24" (WHITE) ⑩ PREFORMED PLASTIC PAVEMENT MARKING, TYPE B, INLAID, LINE 4" (WHITE 2' DASH, 6' SKIP) ⑪ PREFORMED PLASTIC PAVEMENT MARKING, TYPE B, INLAID, LINE 8" (WHITE 3' DASH, 9' SKIP) ⑫ PREFORMED PLASTIC PAVEMENT MARKING, TYPE B, INLAID, LINE 5" (WHITE 10' DASH, 30' SKIP) ⑬ POLYUREA PAVEMENT MARKING TYPE 1, LINE 4" (WHITE EDGE LINE) | <ul style="list-style-type: none"> ⑭ POLYUREA PAVEMENT MARKING TYPE 1, LINE 4" (YELLOW EDGE LINE) ⑮ POLYUREA PAVEMENT MARKING TYPE 1, LINE 8" (WHITE EDGE LINE) ⑯ POLYUREA PAVEMENT MARKING TYPE 1, LINE 5" (WHITE 10' DASH, 30' SKIP) ⑰ POLYUREA PAVEMENT MARKING TYPE 1, LINE 12" (WHITE GORE DIAGONALS SPACED @ 30' CENTERS) ⑱ RAISED REFLECTIVE PAVEMENT MARKER (1-WAY YELLOW / OPAQUE) ⑲ RAISED REFLECTIVE PAVEMENT MARKER (1-WAY CRYSTAL / OPAQUE) ⑳ THERMOPLASTIC PAVEMENT MARKING - LINE 12" (WHITE EDGE LINE) ㉑ THERMOPLASTIC PAVEMENT MARKING - LINE 6" (WHITE THRU LANE LINE) ㉒ POLYUREA PAVEMENT MARKING TYPE 1, LINE 12" (YELLOW DIAGONALS SPACED @ 500' CENTERS) ㉓ POLYUREA PAVEMENT MARKING TYPE 1, LINE 12" (WHITE DIAGONALS SPACED @ 500' CENTERS) ㉔ POLYUREA PAVEMENT MARKING TYPE 1, LETTERS AND SYMBOLS (WHITE) ㉕ POLYUREA PAVEMENT MARKING TYPE 1, LINE 8" (WHITE 3' DASH, 9' SKIP) ㉖ POLYUREA PAVEMENT MARKING TYPE 1, LINE 4" (WHITE 2' DASH, 6' SKIP) |
|--|--|

NOTE:

1. SEE IDOT DISTRICT 1 STANDARD TC-12 "MULTI-LANE FREEWAY PAVEMENT MARKING DETAILS" FOR PLACEMENT AND TYPE OF RAISED REFLECTIVE PAVEMENT MARKERS.
2. FOR PROPOSED PAVEMENT MARKINGS IN THE PCC SECTIONS USE POLYUREA PAVEMENT MARKINGS ACCORDING TO STANDARD TC-12.
3. REFER TO ROADWAY PLANS FOR LIMITS OF RESURFACING.

FILE NAME =	DESIGNED - AJP	REVISED -
USER NAME = tblank	DRAWN - TMB	REVISED -
PLOT DATE = 12/16/2009	CHECKED - JMM	REVISED -
	DATE - 10/16/09	REVISED -

benesch

**STATE OF ILLINOIS
DEPARTMENT OF TRANSPORTATION**

**PAVEMENT MARKING PLANS
STA 653+00 TO STA 668+00**

SCALE: 1"=50' SHEET NO. 12 OF 31 SHEETS STA. TO STA.

F.A.I. RTE.	SECTION	COUNTY	TOTAL SHEETS	SHEET NO.
290	(3031.1, ETC., 3838RS-5	COOK	298	202
CONTRACT NO. 60652				
FED. ROAD DIST. NO. ILLINOIS FED. AID PROJECT				

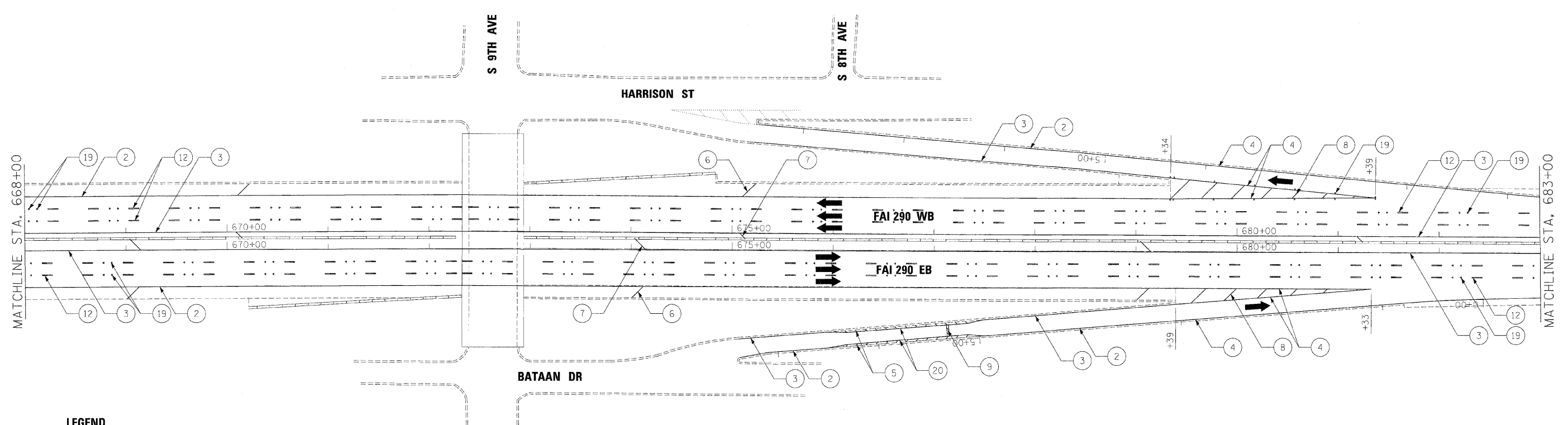

LEGEND

- | | |
|--|--|
| <ul style="list-style-type: none"> ① THERMOPLASTIC PAVEMENT MARKING - LETTERS AND SYMBOLS (WHITE) ② THERMOPLASTIC PAVEMENT MARKING - LINE 4" (WHITE EDGE LINE) ③ THERMOPLASTIC PAVEMENT MARKING - LINE 4" (YELLOW EDGE LINE) ④ THERMOPLASTIC PAVEMENT MARKING - LINE 8" (WHITE EDGE LINE) ⑤ THERMOPLASTIC PAVEMENT MARKING - LINE 8" (WHITE DIAGONALS SPACED @ 10' CENTERS) ⑥ THERMOPLASTIC PAVEMENT MARKING - LINE 12" (WHITE DIAGONALS SPACED @ 500' CENTERS) ⑦ THERMOPLASTIC PAVEMENT MARKING - LINE 12" (YELLOW DIAGONALS SPACED @ 500' CENTERS) ⑧ THERMOPLASTIC PAVEMENT MARKING - LINE 12" (WHITE GORE DIAGONALS SPACED @ 30' CENTERS) ⑨ THERMOPLASTIC PAVEMENT MARKING - LINE 24" (WHITE) ⑩ PREFORMED PLASTIC PAVEMENT MARKING, TYPE B, INLAID, LINE 4" (WHITE 2' DASH, 6' SKIP) ⑪ PREFORMED PLASTIC PAVEMENT MARKING, TYPE B, INLAID, LINE 8" (WHITE 3' DASH, 9' SKIP) ⑫ PREFORMED PLASTIC PAVEMENT MARKING, TYPE B, INLAID, LINE 5" (WHITE 10' DASH, 30' SKIP) ⑬ POLYUREA PAVEMENT MARKING TYPE 1, LINE 4" (WHITE EDGE LINE) | <ul style="list-style-type: none"> ⑭ POLYUREA PAVEMENT MARKING TYPE 1, LINE 4" (YELLOW EDGE LINE) ⑮ POLYUREA PAVEMENT MARKING TYPE 1, LINE 8" (WHITE EDGE LINE) ⑯ POLYUREA PAVEMENT MARKING TYPE 1, LINE 5" (WHITE 10' DASH, 30' SKIP) ⑰ POLYUREA PAVEMENT MARKING TYPE 1, LINE 12" (WHITE GORE DIAGONALS SPACED @ 30' CENTERS) ⑱ RAISED REFLECTIVE PAVEMENT MARKER (1-WAY YELLOW / OPAQUE) ⑲ RAISED REFLECTIVE PAVEMENT MARKER (1-WAY CRYSTAL / OPAQUE) ⑳ THERMOPLASTIC PAVEMENT MARKING - LINE 12" (WHITE EDGE LINE) ㉑ THERMOPLASTIC PAVEMENT MARKING - LINE 6" (WHITE THRU LANE LINE) ㉒ POLYUREA PAVEMENT MARKING TYPE 1, LINE 12" (YELLOW DIAGONALS SPACED @ 500' CENTERS) ㉓ POLYUREA PAVEMENT MARKING TYPE 1, LINE 12" (WHITE DIAGONALS SPACED @ 500' CENTERS) ㉔ POLYUREA PAVEMENT MARKING TYPE 1, LETTERS AND SYMBOLS (WHITE) ㉕ POLYUREA PAVEMENT MARKING TYPE 1, LINE 8" (WHITE 3' DASH, 9' SKIP) ㉖ POLYUREA PAVEMENT MARKING TYPE 1, LINE 4" (WHITE 2' DASH, 6' SKIP) |
|--|--|

NOTE:

1. SEE IDOT DISTRICT 1 STANDARD TC-12 "MULTI-LANE FREEWAY PAVEMENT MARKING DETAILS" FOR PLACEMENT AND TYPE OF RAISED REFLECTIVE PAVEMENT MARKERS.
2. FOR PROPOSED PAVEMENT MARKINGS IN THE PCC SECTIONS USE POLYUREA PAVEMENT MARKINGS ACCORDING TO STANDARD TC-12.
3. REFER TO ROADWAY PLANS FOR LIMITS OF RESURFACING.

FILE NAME =	DESIGNED - AJP	REVISED -
...prpln-ABC-C2-298-pvmtmkg-19.dgn	DRAWN - TMB	REVISED -
USER NAME = tblank	CHECKED - JMM	REVISED -
PLOT DATE = 12/16/2009	DATE - 10/16/09	REVISED -

benesch

**STATE OF ILLINOIS
DEPARTMENT OF TRANSPORTATION**

**PAVEMENT MARKING PLANS
STA 668+00 TO STA 683+00**

SCALE: 1"=50' SHEET NO. 13 OF 31 SHEETS STA. TO STA.

F.A.I. RTE.	SECTION	COUNTY	TOTAL SHEETS	SHEET NO.
290	(3031.1, ETC., 383BIRS-5	COOK	298	203
FED. ROAD DIST. NO. [ILLINOIS] FED. AID PROJECT			CONTRACT NO. 60652	

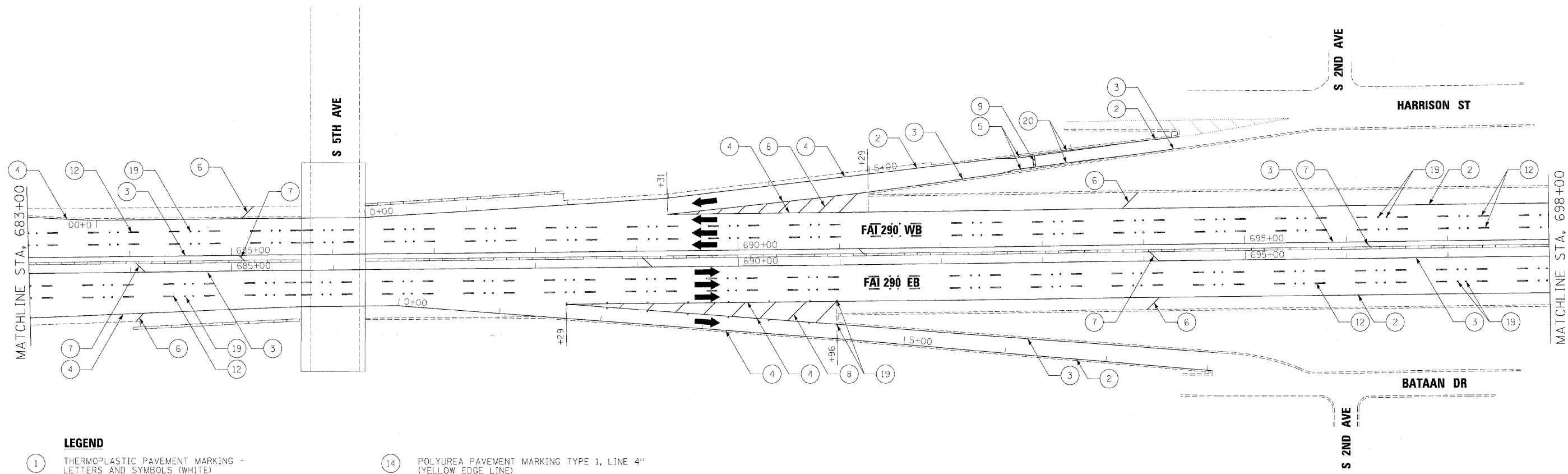

LEGEND

- | | |
|--|--|
| <ul style="list-style-type: none"> ① THERMOPLASTIC PAVEMENT MARKING - LETTERS AND SYMBOLS (WHITE) ② THERMOPLASTIC PAVEMENT MARKING - LINE 4" (WHITE EDGE LINE) ③ THERMOPLASTIC PAVEMENT MARKING - LINE 4" (YELLOW EDGE LINE) ④ THERMOPLASTIC PAVEMENT MARKING - LINE 8" (WHITE EDGE LINE) ⑤ THERMOPLASTIC PAVEMENT MARKING - LINE 8" (WHITE DIAGONALS SPACED @ 10' CENTERS) ⑥ THERMOPLASTIC PAVEMENT MARKING - LINE 12" (WHITE DIAGONALS SPACED @ 500' CENTERS) ⑦ THERMOPLASTIC PAVEMENT MARKING - LINE 12" (YELLOW DIAGONALS SPACED @ 500' CENTERS) ⑧ THERMOPLASTIC PAVEMENT MARKING - LINE 12" (WHITE GORE DIAGONALS SPACED @ 30' CENTERS) ⑨ THERMOPLASTIC PAVEMENT MARKING - LINE 24" (WHITE) ⑩ PREFORMED PLASTIC PAVEMENT MARKING, TYPE B, INLAID, LINE 4" (WHITE 2' DASH, 6' SKIP) ⑪ PREFORMED PLASTIC PAVEMENT MARKING, TYPE B, INLAID, LINE 8" (WHITE 3' DASH, 9' SKIP) ⑫ PREFORMED PLASTIC PAVEMENT MARKING, TYPE B, INLAID, LINE 5" (WHITE 10' DASH, 30' SKIP) ⑬ POLYUREA PAVEMENT MARKING TYPE 1, LINE 4" (WHITE EDGE LINE) | <ul style="list-style-type: none"> ⑭ POLYUREA PAVEMENT MARKING TYPE 1, LINE 4" (YELLOW EDGE LINE) ⑮ POLYUREA PAVEMENT MARKING TYPE 1, LINE 8" (WHITE EDGE LINE) ⑯ POLYUREA PAVEMENT MARKING TYPE 1, LINE 5" (WHITE 10' DASH, 30' SKIP) ⑰ POLYUREA PAVEMENT MARKING TYPE 1, LINE 12" (WHITE GORE DIAGONALS SPACED @ 30' CENTERS) ⑱ RAISED REFLECTIVE PAVEMENT MARKER (1-WAY YELLOW / OPAQUE) ⑲ RAISED REFLECTIVE PAVEMENT MARKER (1-WAY CRYSTAL / OPAQUE) ⑳ THERMOPLASTIC PAVEMENT MARKING - LINE 12" (WHITE EDGE LINE) ㉑ THERMOPLASTIC PAVEMENT MARKING - LINE 6" (WHITE THRU LANE LINE) ㉒ POLYUREA PAVEMENT MARKING TYPE 1, LINE 12" (YELLOW DIAGONALS SPACED @ 500' CENTERS) ㉓ POLYUREA PAVEMENT MARKING TYPE 1, LINE 12" (WHITE DIAGONALS SPACED @ 500' CENTERS) ㉔ POLYUREA PAVEMENT MARKING TYPE 1, LETTERS AND SYMBOLS (WHITE) ㉕ POLYUREA PAVEMENT MARKING TYPE 1, LINE 8" (WHITE 3' DASH, 9' SKIP) ㉖ POLYUREA PAVEMENT MARKING TYPE 1, LINE 4" (WHITE 2' DASH, 6' SKIP) |
|--|--|

NOTE:

1. SEE IDOT DISTRICT 1 STANDARD TC-12 "MULTI-LANE FREEWAY PAVEMENT MARKING DETAILS" FOR PLACEMENT AND TYPE OF RAISED REFLECTIVE PAVEMENT MARKERS.
2. FOR PROPOSED PAVEMENT MARKINGS IN THE PCC SECTIONS USE POLYUREA PAVEMENT MARKINGS ACCORDING TO STANDARD TC-12.
3. REFER TO ROADWAY PLANS FOR LIMITS OF RESURFACING.

FILE NAME =	DESIGNED - AJP	REVISED -
...\\orpin_abc.c2.298_pvtmkg.28.dgn	DRAWN - TMB	REVISED -
USER NAME = tblank	CHECKED - JMM	REVISED -
PLOT DATE = 12/16/2009	DATE - 10/16/09	REVISED -

benesch

**STATE OF ILLINOIS
DEPARTMENT OF TRANSPORTATION**

**PAVEMENT MARKING PLANS
STA 683+00 TO STA 698+00**

SCALE: 1"=50' SHEET NO. 14 OF 31 SHEETS STA. TO STA.

F.A.I. RTE.	SECTION	COUNTY	TOTAL SHEETS	SHEET NO.
290	(3031.1, ETC., 3838)RS-5	COOK	298	204
FED. ROAD DIST. NO. ILLINOIS FED. AID PROJECT			CONTRACT NO. 60C52	

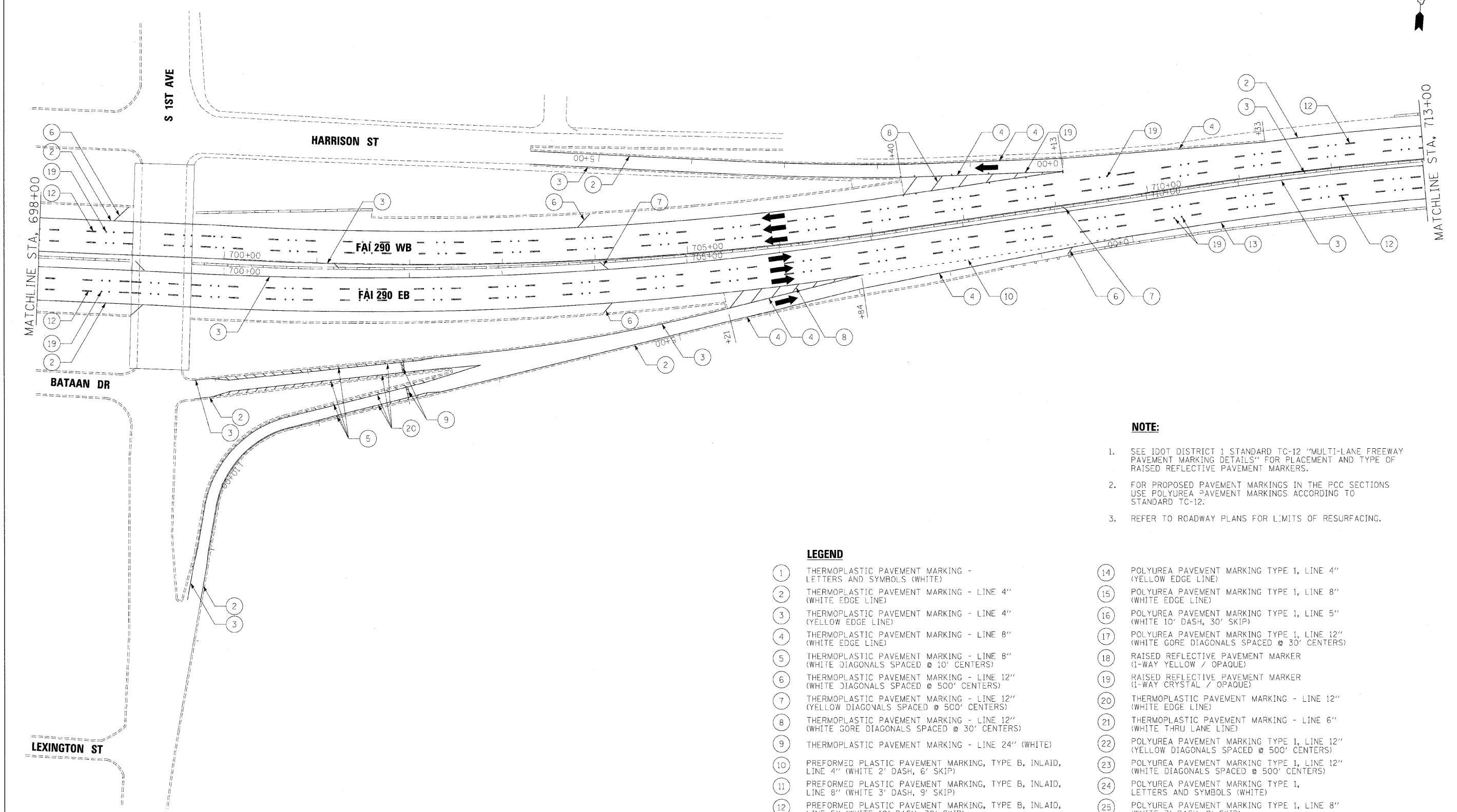

NOTE:

1. SEE IDOT DISTRICT 1 STANDARD TC-12 "MULTI-LANE FREEWAY PAVEMENT MARKING DETAILS" FOR PLACEMENT AND TYPE OF RAISED REFLECTIVE PAVEMENT MARKERS.
2. FOR PROPOSED PAVEMENT MARKINGS IN THE PCC SECTIONS USE POLYUREA PAVEMENT MARKINGS ACCORDING TO STANDARD TC-12.
3. REFER TO ROADWAY PLANS FOR LIMITS OF RESURFACING.

LEGEND

- | | |
|--|--|
| <ul style="list-style-type: none"> ① THERMOPLASTIC PAVEMENT MARKING - LETTERS AND SYMBOLS (WHITE) ② THERMOPLASTIC PAVEMENT MARKING - LINE 4" (WHITE EDGE LINE) ③ THERMOPLASTIC PAVEMENT MARKING - LINE 4" (YELLOW EDGE LINE) ④ THERMOPLASTIC PAVEMENT MARKING - LINE 8" (WHITE EDGE LINE) ⑤ THERMOPLASTIC PAVEMENT MARKING - LINE 8" (WHITE DIAGONALS SPACED @ 10' CENTERS) ⑥ THERMOPLASTIC PAVEMENT MARKING - LINE 12" (WHITE DIAGONALS SPACED @ 500' CENTERS) ⑦ THERMOPLASTIC PAVEMENT MARKING - LINE 12" (YELLOW DIAGONALS SPACED @ 500' CENTERS) ⑧ THERMOPLASTIC PAVEMENT MARKING - LINE 12" (WHITE GORE DIAGONALS SPACED @ 30' CENTERS) ⑨ THERMOPLASTIC PAVEMENT MARKING - LINE 24" (WHITE) ⑩ PREFORMED PLASTIC PAVEMENT MARKING, TYPE B, INLAID, LINE 4" (WHITE 2' DASH, 6' SKIP) ⑪ PREFORMED PLASTIC PAVEMENT MARKING, TYPE B, INLAID, LINE 8" (WHITE 3' DASH, 9' SKIP) ⑫ PREFORMED PLASTIC PAVEMENT MARKING, TYPE B, INLAID, LINE 5" (WHITE 10' DASH, 30' SKIP) ⑬ POLYUREA PAVEMENT MARKING TYPE 1, LINE 4" (WHITE EDGE LINE) | <ul style="list-style-type: none"> ⑭ POLYUREA PAVEMENT MARKING TYPE 1, LINE 4" (YELLOW EDGE LINE) ⑮ POLYUREA PAVEMENT MARKING TYPE 1, LINE 8" (WHITE EDGE LINE) ⑯ POLYUREA PAVEMENT MARKING TYPE 1, LINE 5" (WHITE 10' DASH, 30' SKIP) ⑰ POLYUREA PAVEMENT MARKING TYPE 1, LINE 12" (WHITE GORE DIAGONALS SPACED @ 30' CENTERS) ⑱ RAISED REFLECTIVE PAVEMENT MARKER (1-WAY YELLOW / OPAQUE) ⑲ RAISED REFLECTIVE PAVEMENT MARKER (1-WAY CRYSTAL / OPAQUE) ⑳ THERMOPLASTIC PAVEMENT MARKING - LINE 12" (WHITE EDGE LINE) ㉑ THERMOPLASTIC PAVEMENT MARKING - LINE 6" (WHITE THRU LANE LINE) ㉒ POLYUREA PAVEMENT MARKING TYPE 1, LINE 12" (YELLOW DIAGONALS SPACED @ 500' CENTERS) ㉓ POLYUREA PAVEMENT MARKING TYPE 1, LINE 12" (WHITE DIAGONALS SPACED @ 500' CENTERS) ㉔ POLYUREA PAVEMENT MARKING TYPE 1, LETTERS AND SYMBOLS (WHITE) ㉕ POLYUREA PAVEMENT MARKING TYPE 1, LINE 8" (WHITE 3' DASH, 9' SKIP) ㉖ POLYUREA PAVEMENT MARKING TYPE 1, LINE 4" (WHITE 2' DASH, 6' SKIP) |
|--|--|

FILE NAME =	DESIGNED - AJP	REVISED -
...prolin-ABC.C2.290.pvsmkg.21.dgn	DRAWN - TMB	REVISED -
USER NAME = tblank	CHECKED - JMM	REVISED -
PLOT DATE = 12/16/2009	DATE - 10/16/09	REVISED -

benesch

**STATE OF ILLINOIS
DEPARTMENT OF TRANSPORTATION**

**PAVEMENT MARKING PLANS
STA 698+00 TO STA 713+00**

SCALE: 1"=50' SHEET NO. 15 OF 31 SHEETS STA. TO STA.

F.A.I. RTE.	SECTION	COUNTY	TOTAL SHEETS	SHEET NO.
290	(3031.1, ETC., 383BRS-5	COOK	298	205
FED. ROAD DIST. NO. ILLINOIS FED. AID PROJECT			CONTRACT NO. 60652	

NOTE:

1. SEE IDOT DISTRICT 1 STANDARD TC-12 "MULTI-LANE FREEWAY PAVEMENT MARKING DETAILS" FOR PLACEMENT AND TYPE OF RAISED REFLECTIVE PAVEMENT MARKERS.
2. FOR PROPOSED PAVEMENT MARKINGS IN THE PCC SECTIONS USE POLYUREA PAVEMENT MARKINGS ACCORDING TO STANDARD TC-12.
3. REFER TO ROADWAY PLANS FOR LIMITS OF RESURFACING.

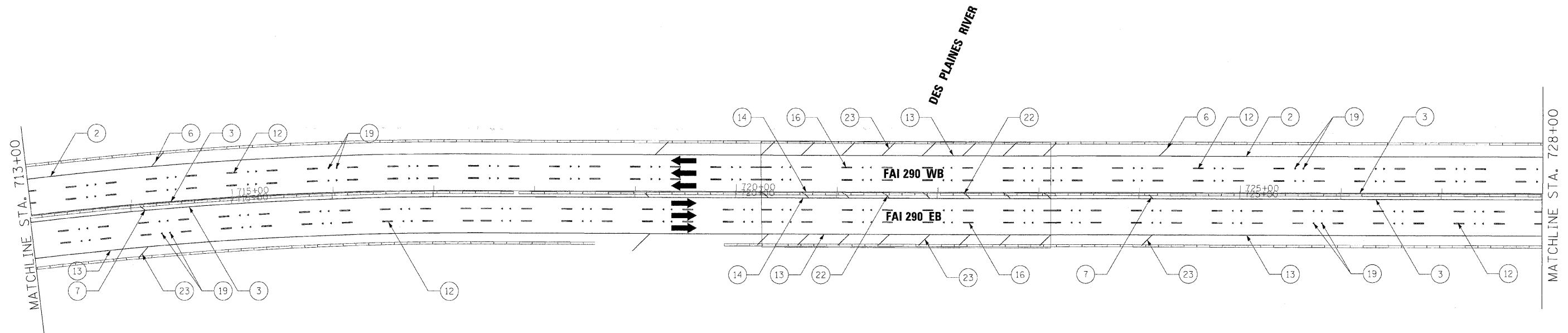

LEGEND

- | | |
|--|--|
| <ul style="list-style-type: none"> ① THERMOPLASTIC PAVEMENT MARKING - LETTERS AND SYMBOLS (WHITE) ② THERMOPLASTIC PAVEMENT MARKING - LINE 4" (WHITE EDGE LINE) ③ THERMOPLASTIC PAVEMENT MARKING - LINE 4" (YELLOW EDGE LINE) ④ THERMOPLASTIC PAVEMENT MARKING - LINE 8" (WHITE EDGE LINE) ⑤ THERMOPLASTIC PAVEMENT MARKING - LINE 8" (WHITE DIAGONALS SPACED @ 10' CENTERS) ⑥ THERMOPLASTIC PAVEMENT MARKING - LINE 12" (WHITE DIAGONALS SPACED @ 500' CENTERS) ⑦ THERMOPLASTIC PAVEMENT MARKING - LINE 12" (YELLOW DIAGONALS SPACED @ 500' CENTERS) ⑧ THERMOPLASTIC PAVEMENT MARKING - LINE 12" (WHITE GORE DIAGONALS SPACED @ 30' CENTERS) ⑨ THERMOPLASTIC PAVEMENT MARKING - LINE 24" (WHITE) ⑩ PREFORMED PLASTIC PAVEMENT MARKING, TYPE B, INLAID, LINE 4" (WHITE 2' DASH, 6' SKIP) ⑪ PREFORMED PLASTIC PAVEMENT MARKING, TYPE B, INLAID, LINE 8" (WHITE 3' DASH, 9' SKIP) ⑫ PREFORMED PLASTIC PAVEMENT MARKING, TYPE B, INLAID, LINE 5" (WHITE 10' DASH, 30' SKIP) ⑬ POLYUREA PAVEMENT MARKING TYPE 1, LINE 4" (WHITE EDGE LINE) | <ul style="list-style-type: none"> ⑭ POLYUREA PAVEMENT MARKING TYPE 1, LINE 4" (YELLOW EDGE LINE) ⑮ POLYUREA PAVEMENT MARKING TYPE 1, LINE 8" (WHITE EDGE LINE) ⑯ POLYUREA PAVEMENT MARKING TYPE 1, LINE 5" (WHITE 10' DASH, 30' SKIP) ⑰ POLYUREA PAVEMENT MARKING TYPE 1, LINE 12" (WHITE GORE DIAGONALS SPACED @ 30' CENTERS) ⑱ RAISED REFLECTIVE PAVEMENT MARKER (1-WAY YELLOW / OPAQUE) ⑲ RAISED REFLECTIVE PAVEMENT MARKER (1-WAY CRYSTAL / OPAQUE) ⑳ THERMOPLASTIC PAVEMENT MARKING - LINE 12" (WHITE EDGE LINE) ㉑ THERMOPLASTIC PAVEMENT MARKING - LINE 6" (WHITE THRU LANE LINE) ㉒ POLYUREA PAVEMENT MARKING TYPE 1, LINE 12" (YELLOW DIAGONALS SPACED @ 500' CENTERS) ㉓ POLYUREA PAVEMENT MARKING TYPE 1, LINE 12" (WHITE DIAGONALS SPACED @ 500' CENTERS) ㉔ POLYUREA PAVEMENT MARKING TYPE 1, LETTERS AND SYMBOLS (WHITE) ㉕ POLYUREA PAVEMENT MARKING TYPE 1, LINE 8" (WHITE 3' DASH, 9' SKIP) ㉖ POLYUREA PAVEMENT MARKING TYPE 1, LINE 4" (WHITE 2' DASH, 6' SKIP) |
|--|--|

FILE NAME =	DESIGNED - AJP	REVISED -
...prpIn_ABC.C2.298_pvmnkg.22.dgn	DRAWN - TMB	REVISED -
USER NAME = tblank	CHECKED - JMM	REVISED -
PLOT DATE = 12/16/2009	DATE - 10/16/09	REVISED -

benesch

**STATE OF ILLINOIS
DEPARTMENT OF TRANSPORTATION**

**PAVEMENT MARKING PLANS
STA 713+00 TO STA 728+00**

SCALE: 1"=50' SHEET NO. 16 OF 31 SHEETS STA. TO STA.

F.A.I. RTE.	SECTION	COUNTY	TOTAL SHEETS	SHEET NO.
290	(3031.1, ETC., 3838)RS-5	COOK	298	206
FED. ROAD DIST. NO.			ILLINOIS FED. AID PROJECT	
			CONTRACT NO. 60G52	

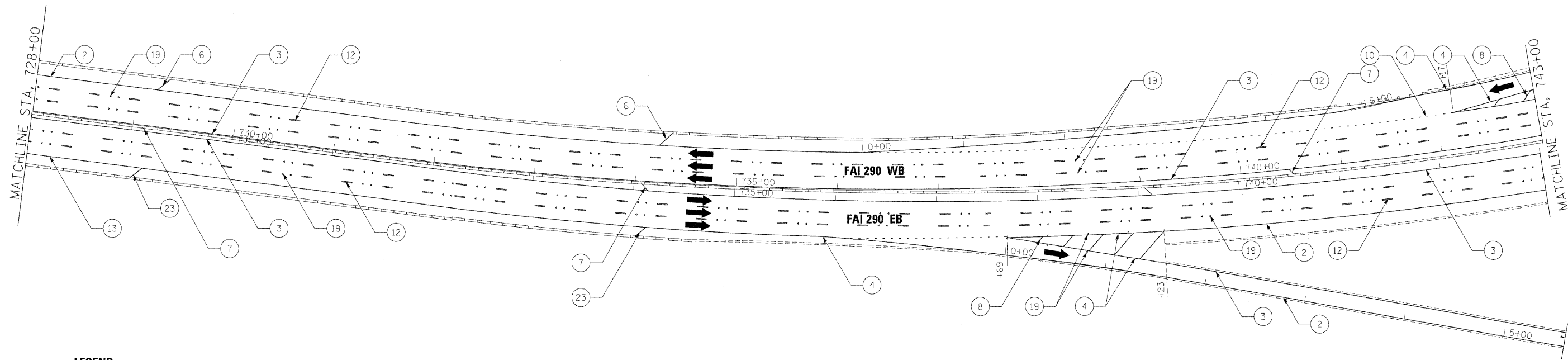

LEGEND

- | | |
|--|---|
| <ul style="list-style-type: none"> 1 THERMOPLASTIC PAVEMENT MARKING - LETTERS AND SYMBOLS (WHITE) 2 THERMOPLASTIC PAVEMENT MARKING - LINE 4" (WHITE EDGE LINE) 3 THERMOPLASTIC PAVEMENT MARKING - LINE 4" (YELLOW EDGE LINE) 4 THERMOPLASTIC PAVEMENT MARKING - LINE 8" (WHITE EDGE LINE) 5 THERMOPLASTIC PAVEMENT MARKING - LINE 8" (WHITE DIAGONALS SPACED @ 10' CENTERS) 6 THERMOPLASTIC PAVEMENT MARKING - LINE 12" (WHITE DIAGONALS SPACED @ 500' CENTERS) 7 THERMOPLASTIC PAVEMENT MARKING - LINE 12" (YELLOW DIAGONALS SPACED @ 500' CENTERS) 8 THERMOPLASTIC PAVEMENT MARKING - LINE 12" (WHITE GORE DIAGONALS SPACED @ 30' CENTERS) 9 THERMOPLASTIC PAVEMENT MARKING - LINE 24" (WHITE) 10 PREFORMED PLASTIC PAVEMENT MARKING, TYPE B, INLAID, LINE 4" (WHITE 2' DASH, 6' SKIP) 11 PREFORMED PLASTIC PAVEMENT MARKING, TYPE B, INLAID, LINE 8" (WHITE 3' DASH, 9' SKIP) 12 PREFORMED PLASTIC PAVEMENT MARKING, TYPE B, INLAID, LINE 5" (WHITE 10' DASH, 30' SKIP) 13 POLYUREA PAVEMENT MARKING TYPE 1, LINE 4" (WHITE EDGE LINE) | <ul style="list-style-type: none"> 14 POLYUREA PAVEMENT MARKING TYPE 1, LINE 4" (YELLOW EDGE LINE) 15 POLYUREA PAVEMENT MARKING TYPE 1, LINE 8" (WHITE EDGE LINE) 16 POLYUREA PAVEMENT MARKING TYPE 1, LINE 5" (WHITE 10' DASH, 30' SKIP) 17 POLYUREA PAVEMENT MARKING TYPE 1, LINE 12" (WHITE GORE DIAGONALS SPACED @ 30' CENTERS) 18 RAISED REFLECTIVE PAVEMENT MARKER (1-WAY YELLOW / OPAQUE) 19 RAISED REFLECTIVE PAVEMENT MARKER (1-WAY CRYSTAL / OPAQUE) 20 THERMOPLASTIC PAVEMENT MARKING - LINE 12" (WHITE EDGE LINE) 21 THERMOPLASTIC PAVEMENT MARKING - LINE 6" (WHITE THRU LANE LINE) 22 POLYUREA PAVEMENT MARKING TYPE 1, LINE 12" (YELLOW DIAGONALS SPACED @ 500' CENTERS) 23 POLYUREA PAVEMENT MARKING TYPE 1, LINE 12" (WHITE DIAGONALS SPACED @ 500' CENTERS) 24 POLYUREA PAVEMENT MARKING TYPE 1, LETTERS AND SYMBOLS (WHITE) 25 POLYUREA PAVEMENT MARKING TYPE 1, LINE 8" (WHITE 3' DASH, 9' SKIP) 26 POLYUREA PAVEMENT MARKING TYPE 1, LINE 4" (WHITE 2' DASH, 6' SKIP) |
|--|---|

NOTE:

1. SEE IDOT DISTRICT 1 STANDARD TC-12 "MULTI-LANE FREEWAY PAVEMENT MARKING DETAILS" FOR PLACEMENT AND TYPE OF RAISED REFLECTIVE PAVEMENT MARKERS.
2. FOR PROPOSED PAVEMENT MARKINGS IN THE PCC SECTIONS USE POLYUREA PAVEMENT MARKINGS ACCORDING TO STANDARD TC-12.
3. REFER TO ROADWAY PLANS FOR LIMITS OF RESURFACING.

FILE NAME =	DESIGNED - AJP	REVISED -
...prpln_ABC_C2.290_pvtmknkg_23.dgn	DRAWN - TMB	REVISED -
USER NAME = tblank	CHECKED - JMM	REVISED -
PLOT DATE = 12/16/2009	DATE - 10/16/09	REVISED -

benesch

**STATE OF ILLINOIS
DEPARTMENT OF TRANSPORTATION**

**PAVEMENT MARKING PLANS
STA 728+00 TO STA 743+00**

SCALE: 1"=50' SHEET NO. 17 OF 31 SHEETS STA. TO STA.

F.A. RTE.	SECTION	COUNTY	TOTAL SHEETS	SHEET NO.
290	(3031.1, ETC., 3838/RS-5	COOK	298	207
FED. ROAD DIST. NO.			ILLINOIS FED. AID PROJECT	
			CONTRACT NO. 60652	

NOTE:

- SEE IDOT DISTRICT 1 STANDARD TC-12 "MULTI-LANE FREEWAY PAVEMENT MARKING DETAILS" FOR PLACEMENT AND TYPE OF RAISED REFLECTIVE PAVEMENT MARKERS.
- FOR PROPOSED PAVEMENT MARKINGS IN THE PCC SECTIONS USE POLYUREA PAVEMENT MARKINGS ACCORDING TO STANDARD TC-12.
- REFER TO ROADWAY PLANS FOR LIMITS OF RESURFACING.

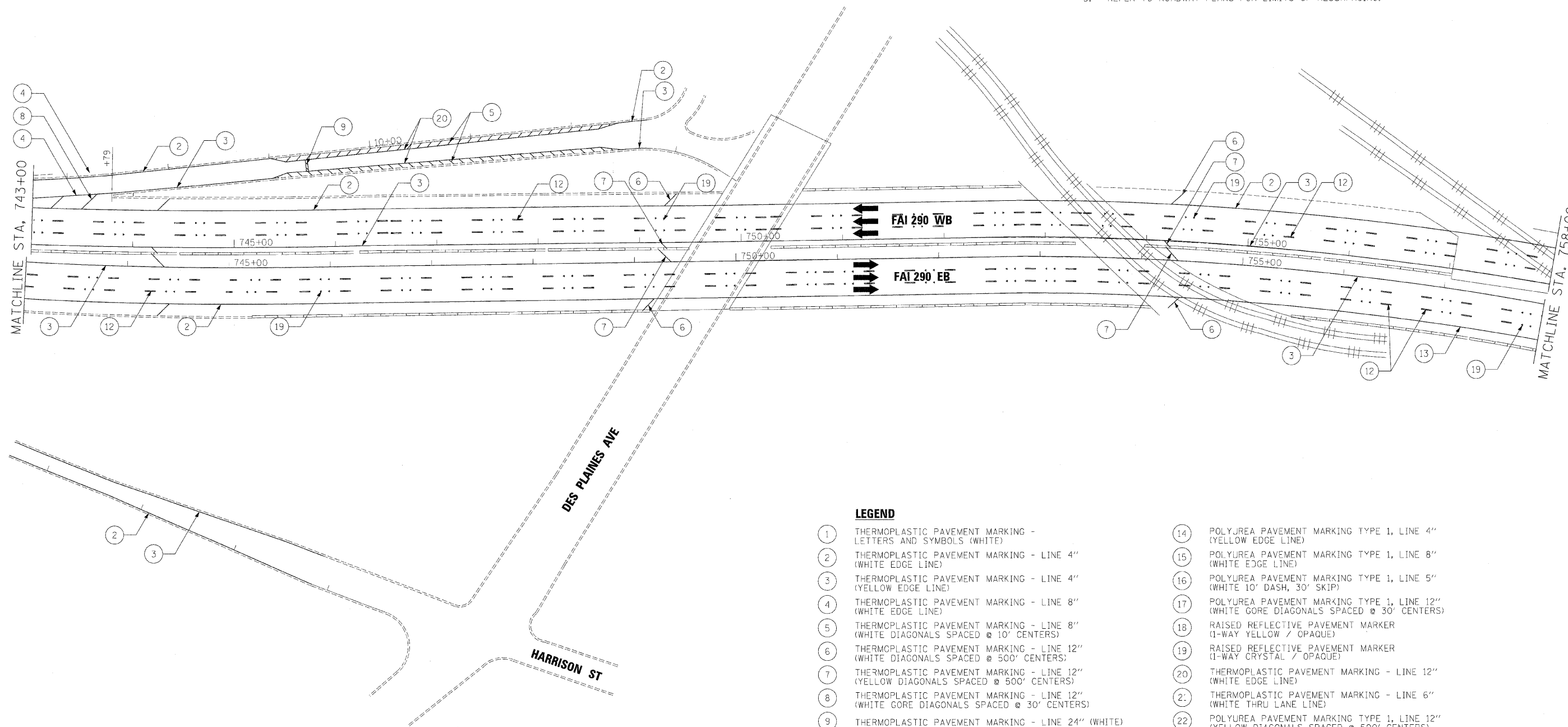

LEGEND

- | | | | |
|----|--|----|--|
| 1 | THERMOPLASTIC PAVEMENT MARKING - LETTERS AND SYMBOLS (WHITE) | 14 | POLYUREA PAVEMENT MARKING TYPE 1, LINE 4" (YELLOW EDGE LINE) |
| 2 | THERMOPLASTIC PAVEMENT MARKING - LINE 4" (WHITE EDGE LINE) | 15 | POLYUREA PAVEMENT MARKING TYPE 1, LINE 8" (WHITE EDGE LINE) |
| 3 | THERMOPLASTIC PAVEMENT MARKING - LINE 4" (YELLOW EDGE LINE) | 16 | POLYUREA PAVEMENT MARKING TYPE 1, LINE 5" (WHITE 10' DASH, 30' SKIP) |
| 4 | THERMOPLASTIC PAVEMENT MARKING - LINE 8" (WHITE EDGE LINE) | 17 | POLYUREA PAVEMENT MARKING TYPE 1, LINE 12" (WHITE GORE DIAGONALS SPACED @ 30' CENTERS) |
| 5 | THERMOPLASTIC PAVEMENT MARKING - LINE 8" (WHITE DIAGONALS SPACED @ 10' CENTERS) | 18 | RAISED REFLECTIVE PAVEMENT MARKER (1-WAY YELLOW / OPAQUE) |
| 6 | THERMOPLASTIC PAVEMENT MARKING - LINE 12" (WHITE DIAGONALS SPACED @ 500' CENTERS) | 19 | RAISED REFLECTIVE PAVEMENT MARKER (1-WAY CRYSTAL / OPAQUE) |
| 7 | THERMOPLASTIC PAVEMENT MARKING - LINE 12" (YELLOW DIAGONALS SPACED @ 500' CENTERS) | 20 | THERMOPLASTIC PAVEMENT MARKING - LINE 12" (WHITE EDGE LINE) |
| 8 | THERMOPLASTIC PAVEMENT MARKING - LINE 12" (WHITE GORE DIAGONALS SPACED @ 30' CENTERS) | 21 | THERMOPLASTIC PAVEMENT MARKING - LINE 6" (WHITE THRU LANE LINE) |
| 9 | THERMOPLASTIC PAVEMENT MARKING - LINE 24" (WHITE) | 22 | POLYUREA PAVEMENT MARKING TYPE 1, LINE 12" (YELLOW DIAGONALS SPACED @ 500' CENTERS) |
| 10 | PREFORMED PLASTIC PAVEMENT MARKING, TYPE B, INLAID, LINE 4" (WHITE 2' DASH, 6' SKIP) | 23 | POLYUREA PAVEMENT MARKING TYPE 1, LINE 12" (WHITE DIAGONALS SPACED @ 500' CENTERS) |
| 11 | PREFORMED PLASTIC PAVEMENT MARKING, TYPE B, INLAID, LINE 8" (WHITE 3' DASH, 9' SKIP) | 24 | POLYUREA PAVEMENT MARKING TYPE 1, LETTERS AND SYMBOLS (WHITE) |
| 12 | PREFORMED PLASTIC PAVEMENT MARKING, TYPE B, INLAID, LINE 5" (WHITE 10' DASH, 30' SKIP) | 25 | POLYUREA PAVEMENT MARKING TYPE 1, LINE 8" (WHITE 3' DASH, 9' SKIP) |
| 13 | POLYUREA PAVEMENT MARKING TYPE 1, LINE 4" (WHITE EDGE LINE) | 26 | POLYUREA PAVEMENT MARKING TYPE 1, LINE 4" (WHITE 2' DASH, 6' SKIP) |

FILE NAME =	DESIGNED -	AJP	REVISED -	
\\prip\In-ABC\C2.290_pvm\mkg_24.dgn	DRAWN -	TMB	REVISED -	
USER NAME = tblank	CHECKED -	JMM	REVISED -	
PLDT DATE = 12/16/2009	DATE -	10/16/09	REVISED -	

benesch

**STATE OF ILLINOIS
DEPARTMENT OF TRANSPORTATION**

**PAVEMENT MARKING PLANS
STA 743+00 TO STA 758+00**

SCALE: 1"=50' SHEET NO. 18 OF 31 SHEETS STA. TO STA.

F.A.I. RTE.	SECTION	COUNTY	TOTAL SHEETS	SHEET NO.
290	(3031.1, ETC., 3838)RS-5	COOK	298	208
FED. ROAD DIST. NO.			ILLINOIS FED. AID PROJECT	
			CONTRACT NO. 60G52	

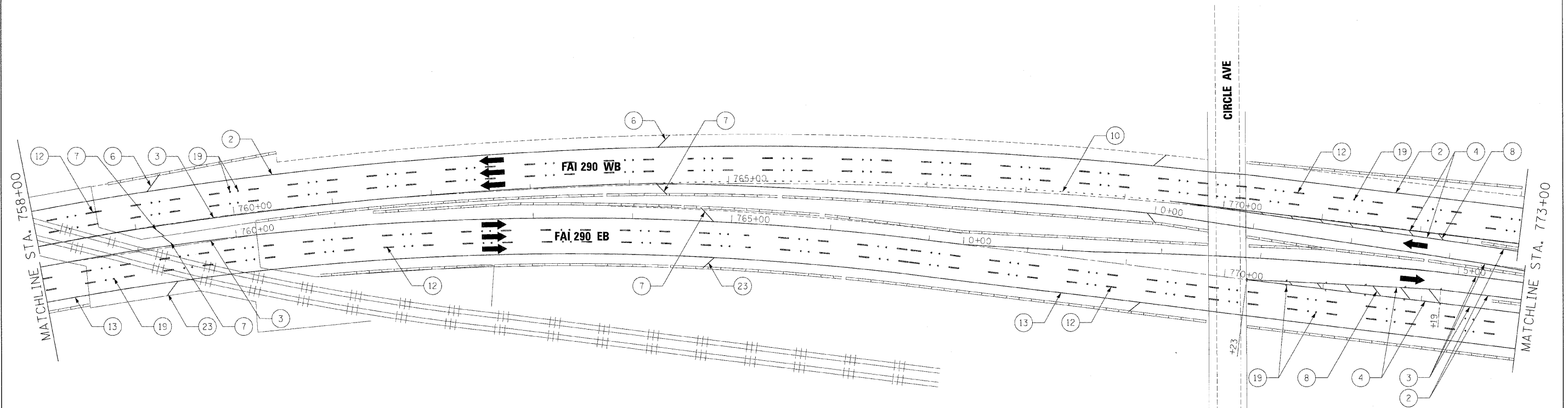

LEGEND

- | | |
|--|--|
| ① THERMOPLASTIC PAVEMENT MARKING - LETTERS AND SYMBOLS (WHITE) | ⑭ POLYUREA PAVEMENT MARKING TYPE 1, LINE 4" (YELLOW EDGE LINE) |
| ② THERMOPLASTIC PAVEMENT MARKING - LINE 4" (WHITE EDGE LINE) | ⑮ POLYUREA PAVEMENT MARKING TYPE 1, LINE 8" (WHITE EDGE LINE) |
| ③ THERMOPLASTIC PAVEMENT MARKING - LINE 4" (YELLOW EDGE LINE) | ⑯ POLYUREA PAVEMENT MARKING TYPE 1, LINE 5" (WHITE 10' DASH, 30' SKIP) |
| ④ THERMOPLASTIC PAVEMENT MARKING - LINE 8" (WHITE EDGE LINE) | ⑰ POLYUREA PAVEMENT MARKING TYPE 1, LINE 12" (WHITE GORE DIAGONALS SPACED @ 30' CENTERS) |
| ⑤ THERMOPLASTIC PAVEMENT MARKING - LINE 8" (WHITE DIAGONALS SPACED @ 10' CENTERS) | ⑱ RAISED REFLECTIVE PAVEMENT MARKER (1-WAY YELLOW / OPAQUE) |
| ⑥ THERMOPLASTIC PAVEMENT MARKING - LINE 12" (WHITE DIAGONALS SPACED @ 500' CENTERS) | ⑲ RAISED REFLECTIVE PAVEMENT MARKER (1-WAY CRYSTAL / OPAQUE) |
| ⑦ THERMOPLASTIC PAVEMENT MARKING - LINE 12" (YELLOW DIAGONALS SPACED @ 500' CENTERS) | ⑳ THERMOPLASTIC PAVEMENT MARKING - LINE 12" (WHITE EDGE LINE) |
| ⑧ THERMOPLASTIC PAVEMENT MARKING - LINE 12" (WHITE GORE DIAGONALS SPACED @ 30' CENTERS) | ㉑ THERMOPLASTIC PAVEMENT MARKING - LINE 6" (WHITE THRU LANE LINE) |
| ⑨ THERMOPLASTIC PAVEMENT MARKING - LINE 24" (WHITE) | ㉒ POLYUREA PAVEMENT MARKING TYPE 1, LINE 12" (YELLOW DIAGONALS SPACED @ 500' CENTERS) |
| ⑩ PREFORMED PLASTIC PAVEMENT MARKING, TYPE B, INLAID, LINE 4" (WHITE 2' DASH, 6' SKIP) | ㉓ POLYUREA PAVEMENT MARKING TYPE 1, LINE 12" (WHITE DIAGONALS SPACED @ 500' CENTERS) |
| ⑪ PREFORMED PLASTIC PAVEMENT MARKING, TYPE B, INLAID, LINE 8" (WHITE 3' DASH, 9' SKIP) | ㉔ POLYUREA PAVEMENT MARKING TYPE 1, LETTERS AND SYMBOLS (WHITE) |
| ⑫ PREFORMED PLASTIC PAVEMENT MARKING, TYPE B, INLAID, LINE 5" (WHITE 10' DASH, 30' SKIP) | ㉕ POLYUREA PAVEMENT MARKING TYPE 1, LINE 8" (WHITE 3' DASH, 9' SKIP) |
| ⑬ POLYUREA PAVEMENT MARKING TYPE 1, LINE 4" (WHITE EDGE LINE) | ㉖ POLYUREA PAVEMENT MARKING TYPE 1, LINE 4" (WHITE 2' DASH, 6' SKIP) |

NOTE:

- SEE IDOT DISTRICT 1 STANDARD TC-12 "MULTI-LANE FREEWAY PAVEMENT MARKING DETAILS" FOR PLACEMENT AND TYPE OF RAISED REFLECTIVE PAVEMENT MARKERS.
- FOR PROPOSED PAVEMENT MARKINGS IN THE PCC SECTIONS USE POLYUREA PAVEMENT MARKINGS ACCORDING TO STANDARD "C-12."
- REFER TO ROADWAY PLANS FOR LIMITS OF RESURFACING.

FILE NAME =	DESIGNED - AJP	REVISED -
...prp17-ABC.C2.298_pvmznkg.25.dgn	DRAWN - TMB	REVISED -
USER NAME = tblank	CHECKED - JMM	REVISED -
PLOT DATE = 12/16/2009	DATE - 10/16/09	REVISED -

benesch

**STATE OF ILLINOIS
DEPARTMENT OF TRANSPORTATION**

**PAVEMENT MARKING PLANS
STA 758+00 TO STA 773+00**

SCALE: 1"=50' SHEET NO. 19 OF 31 SHEETS STA. TO STA.

F.A.I. RTE.	SECTION	COUNTY	TOTAL SHEETS	SHEET NO.
290	(3031.1, ETC., 3838)RS-5	COOK	298	209
FED. ROAD DIST. NO. ILLINOIS FED. AID PROJECT			CONTRACT NO. 60652	

NOTE:

- SEE IDCT DISTRICT 1 STANDARD TC-12 "MULTI-LANE FREEWAY PAVEMENT MARKING DETAILS" FOR PLACEMENT AND TYPE OF RAISED REFLECTIVE PAVEMENT MARKERS.
- FOR PROPOSED PAVEMENT MARKINGS IN THE PCC SECTIONS USE POLYUREA PAVEMENT MARKINGS ACCORDING TO STANDARD TC-12.
- REFER TO ROADWAY PLANS FOR LIMITS OF RESURFACING.

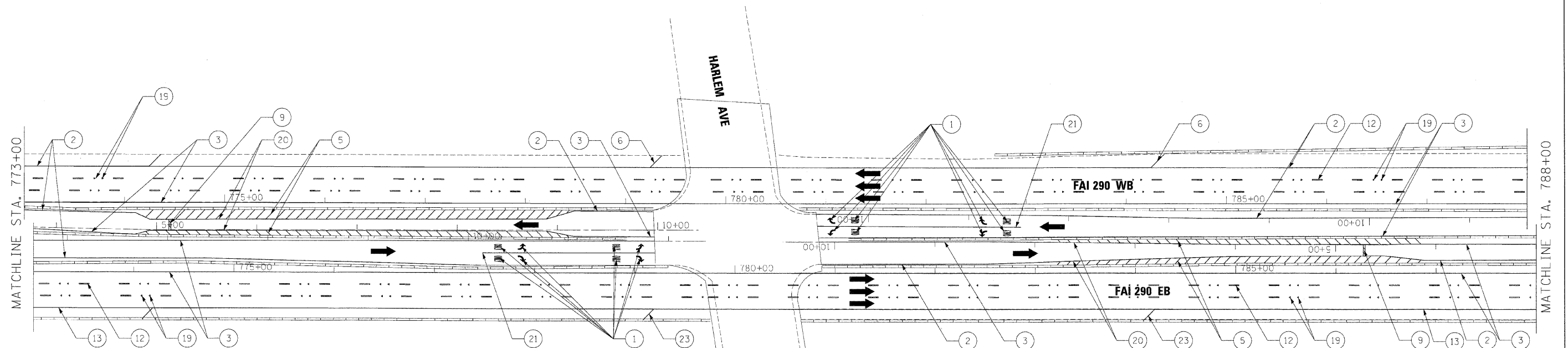

LEGEND

- | | | | |
|----|--|----|--|
| 1 | THERMOPLASTIC PAVEMENT MARKING - LETTERS AND SYMBOLS (WHITE) | 14 | POLYUREA PAVEMENT MARKING TYPE 1, LINE 4" (YELLOW EDGE LINE) |
| 2 | THERMOPLASTIC PAVEMENT MARKING - LINE 4" (WHITE EDGE LINE) | 15 | POLYUREA PAVEMENT MARKING TYPE 1, LINE 8" (WHITE EDGE LINE) |
| 3 | THERMOPLASTIC PAVEMENT MARKING - LINE 4" (YELLOW EDGE LINE) | 16 | POLYUREA PAVEMENT MARKING TYPE 1, LINE 5" (WHITE 10' DASH, 30' SKIP) |
| 4 | THERMOPLASTIC PAVEMENT MARKING - LINE 8" (WHITE EDGE LINE) | 17 | POLYUREA PAVEMENT MARKING TYPE 1, LINE 12" (WHITE CORE DIAGONALS SPACED @ 30' CENTERS) |
| 5 | THERMOPLASTIC PAVEMENT MARKING - LINE 8" (WHITE DIAGONALS SPACED @ 10' CENTERS) | 18 | RAISED REFLECTIVE PAVEMENT MARKER (1-WAY YELLOW / OPAQUE) |
| 6 | THERMOPLASTIC PAVEMENT MARKING - LINE 12" (WHITE DIAGONALS SPACED @ 500' CENTERS) | 19 | RAISED REFLECTIVE PAVEMENT MARKER (1-WAY CRYSTAL / OPAQUE) |
| 7 | THERMOPLASTIC PAVEMENT MARKING - LINE 12" (YELLOW DIAGONALS SPACED @ 500' CENTERS) | 20 | THERMOPLASTIC PAVEMENT MARKING - LINE 12" (WHITE EDGE LINE) |
| 8 | THERMOPLASTIC PAVEMENT MARKING - LINE 12" (WHITE GORE DIAGONALS SPACED @ 30' CENTERS) | 21 | THERMOPLASTIC PAVEMENT MARKING - LINE 6" (WHITE THRU LANE LINE) |
| 9 | THERMOPLASTIC PAVEMENT MARKING - LINE 24" (WHITE) | 22 | POLYUREA PAVEMENT MARKING TYPE 1, LINE 12" (YELLOW DIAGONALS SPACED @ 500' CENTERS) |
| 10 | PREFORMED PLASTIC PAVEMENT MARKING, TYPE B, INLAID, LINE 4" (WHITE 2' DASH, 6' SKIP) | 23 | POLYUREA PAVEMENT MARKING TYPE 1, LINE 12" (WHITE DIAGONALS SPACED @ 500' CENTERS) |
| 11 | PREFORMED PLASTIC PAVEMENT MARKING, TYPE B, INLAID, LINE 8" (WHITE 3' DASH, 9' SKIP) | 24 | POLYUREA PAVEMENT MARKING TYPE 1, LETTERS AND SYMBOLS (WHITE) |
| 12 | PREFORMED PLASTIC PAVEMENT MARKING, TYPE B, INLAID, LINE 5" (WHITE 10' DASH, 30' SKIP) | 25 | POLYUREA PAVEMENT MARKING TYPE 1, LINE 8" (WHITE 3' DASH, 9' SKIP) |
| 13 | POLYUREA PAVEMENT MARKING TYPE 1, LINE 4" (WHITE EDGE LINE) | 26 | POLYUREA PAVEMENT MARKING TYPE 1, LINE 4" (WHITE 2' DASH, 6' SKIP) |

FILE NAME =	DESIGNED - AJP	REVISED -
...praln_ABC.C2.290_pvmnkg.26.dgn	DRAWN - TMB	REVISED -
USER NAME = tblank	CHECKED - JMM	REVISED -
PLOT DATE = 12/6/2009	DATE - 10/16/09	REVISED -

benesch

**STATE OF ILLINOIS
DEPARTMENT OF TRANSPORTATION**

**PAVEMENT MARKING PLANS
STA 773+00 TO STA 788+00**

SCALE: 1"=50' SHEET NO. 20 OF 31 SHEETS STA. TO STA.

F.A.I. RTE.	SECTION	COUNTY	TOTAL SHEETS	SHEET NO.
290	(3031.1, ETC., 3838)RS-5	COOK	298	210
FED. ROAD DIST. NO.			ILLINOIS FED. AID PROJECT	
			CONTRACT NO. 60652	



NOTE:

1. SEE IDOT DISTRICT 1 STANDARD TC-12 "MULTI-LANE FREEWAY PAVEMENT MARKING DETAILS" FOR PLACEMENT AND TYPE OF RAISED REFLECTIVE PAVEMENT MARKERS.
2. FOR PROPOSED PAVEMENT MARKINGS IN THE PCC SECTIONS USE POLYUREA PAVEMENT MARKINGS ACCORDING TO STANDARD TC-12.
3. REFER TO ROADWAY PLANS FOR LIMITS OF RESURFACING.

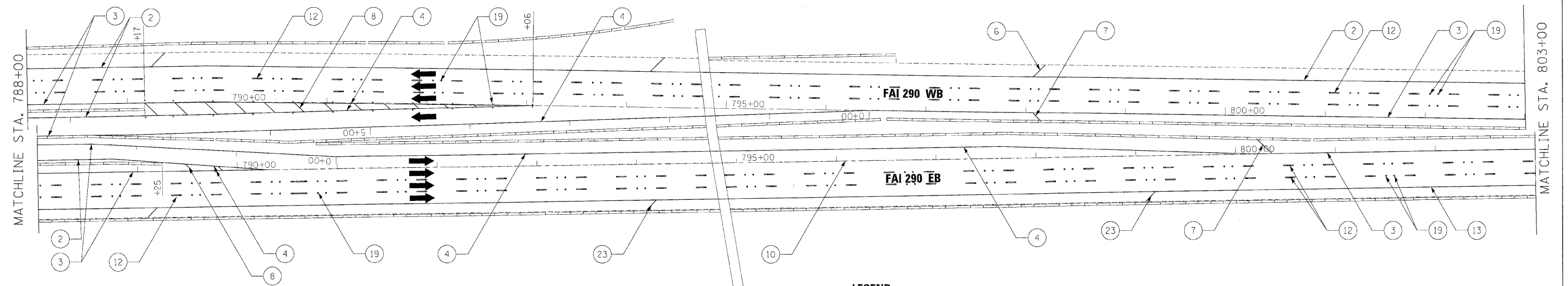

LEGEND

- | | |
|--|--|
| <ul style="list-style-type: none"> ① THERMOPLASTIC PAVEMENT MARKING - LETTERS AND SYMBOLS (WHITE) ② THERMOPLASTIC PAVEMENT MARKING - LINE 4" (WHITE EDGE LINE) ③ THERMOPLASTIC PAVEMENT MARKING - LINE 4" (YELLOW EDGE LINE) ④ THERMOPLASTIC PAVEMENT MARKING - LINE 8" (WHITE EDGE LINE) ⑤ THERMOPLASTIC PAVEMENT MARKING - LINE 8" (WHITE DIAGONALS SPACED @ 10' CENTERS) ⑥ THERMOPLASTIC PAVEMENT MARKING - LINE 12" (WHITE DIAGONALS SPACED @ 500' CENTERS) ⑦ THERMOPLASTIC PAVEMENT MARKING - LINE 12" (YELLOW DIAGONALS SPACED @ 500' CENTERS) ⑧ THERMOPLASTIC PAVEMENT MARKING - LINE 12" (WHITE GORE DIAGONALS SPACED @ 30' CENTERS) ⑨ THERMOPLASTIC PAVEMENT MARKING - LINE 24" (WHITE) ⑩ PREFORMED PLASTIC PAVEMENT MARKING, TYPE B, INLAID, LINE 4" (WHITE 2' DASH, 6' SKIP) ⑪ PREFORMED PLASTIC PAVEMENT MARKING, TYPE B, INLAID, LINE 8" (WHITE 3' DASH, 9' SKIP) ⑫ PREFORMED PLASTIC PAVEMENT MARKING, TYPE B, INLAID, LINE 5" (WHITE 10' DASH, 30' SKIP) ⑬ POLYUREA PAVEMENT MARKING TYPE 1, LINE 4" (WHITE EDGE LINE) | <ul style="list-style-type: none"> ⑭ POLYUREA PAVEMENT MARKING TYPE 1, LINE 4" (YELLOW EDGE LINE) ⑮ POLYUREA PAVEMENT MARKING TYPE 1, LINE 8" (WHITE EDGE LINE) ⑯ POLYUREA PAVEMENT MARKING TYPE 1, LINE 5" (WHITE 10' DASH, 30' SKIP) ⑰ POLYUREA PAVEMENT MARKING TYPE 1, LINE 12" (WHITE GORE DIAGONALS SPACED @ 30' CENTERS) ⑱ RAISED REFLECTIVE PAVEMENT MARKER (1-WAY YELLOW / OPAQUE) ⑲ RAISED REFLECTIVE PAVEMENT MARKER (1-WAY CRYSTAL / OPAQUE) ⑳ THERMOPLASTIC PAVEMENT MARKING - LINE 12" (WHITE EDGE LINE) ㉑ THERMOPLASTIC PAVEMENT MARKING - LINE 6" (WHITE THRU LANE LINE) ㉒ POLYUREA PAVEMENT MARKING TYPE 1, LINE 12" (YELLOW DIAGONALS SPACED @ 500' CENTERS) ㉓ POLYUREA PAVEMENT MARKING TYPE 1, LINE 12" (WHITE DIAGONALS SPACED @ 500' CENTERS) ㉔ POLYUREA PAVEMENT MARKING TYPE 1, LETTERS AND SYMBOLS (WHITE) ㉕ POLYUREA PAVEMENT MARKING TYPE 1, LINE 8" (WHITE 3' DASH, 9' SKIP) ㉖ POLYUREA PAVEMENT MARKING TYPE 1, LINE 4" (WHITE 2' DASH, 6' SKIP) |
|--|--|

FILE NAME =	DESIGNED - AJP	REVISED -
...prpIn_PBC_C2_290_svrntnkg_27.dgn	DRAWN - TMB	REVISED -
USFR NAME = tblank	CHECKED - JMM	REVISED -
PLOT DATE = 12/16/2009	DATE - 10/16/09	REVISED -

benesch

**STATE OF ILLINOIS
DEPARTMENT OF TRANSPORTATION**

**PAVEMENT MARKING PLANS
STA 788+00 TO STA 803+00**

SCALE: 1"=50' SHEET NO. 21 OF 31 SHEETS STA. TO STA.

F.A.I. RTE.	SECTION	COUNTY	TOTAL SHEETS	SHEET NO.
290	(3031.1, ETC., 3838)RS-5	COOK	298	211
FED. ROAD DIST. NO. ILLINOIS FED. AID PROJECT			CONTRACT NO. 60C52	

NOTE:

1. SEE IDOT DISTRICT 1 STANDARD TC-12 "MULTI-LANE FREEWAY PAVEMENT MARKING DETAILS" FOR PLACEMENT AND TYPE OF RAISED REFLECTIVE PAVEMENT MARKERS.
2. FOR PROPOSED PAVEMENT MARKINGS IN THE PCC SECTIONS USE POLYUREA PAVEMENT MARKINGS ACCORDING TO STANDARD TC-12.
3. REFER TO ROADWAY PLANS FOR LIMITS OF RESURFACING.

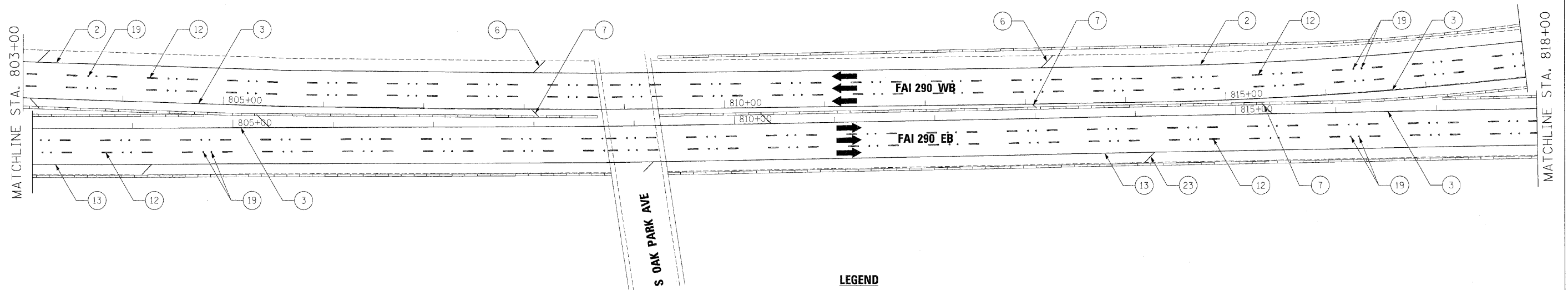

LEGEND

- | | |
|--|--|
| <ul style="list-style-type: none"> ① THERMOPLASTIC PAVEMENT MARKING - LETTERS AND SYMBOLS (WHITE) ② THERMOPLASTIC PAVEMENT MARKING - LINE 4" (WHITE EDGE LINE) ③ THERMOPLASTIC PAVEMENT MARKING - LINE 4" (YELLOW EDGE LINE) ④ THERMOPLASTIC PAVEMENT MARKING - LINE 8" (WHITE EDGE LINE) ⑤ THERMOPLASTIC PAVEMENT MARKING - LINE 8" (WHITE DIAGONALS SPACED @ 10' CENTERS) ⑥ THERMOPLASTIC PAVEMENT MARKING - LINE 12" (WHITE DIAGONALS SPACED @ 500' CENTERS) ⑦ THERMOPLASTIC PAVEMENT MARKING - LINE 12" (YELLOW DIAGONALS SPACED @ 500' CENTERS) ⑧ THERMOPLASTIC PAVEMENT MARKING - LINE 12" (WHITE GORE DIAGONALS SPACED @ 30' CENTERS) ⑨ THERMOPLASTIC PAVEMENT MARKING - LINE 24" (WHITE) ⑩ PREFORMED PLASTIC PAVEMENT MARKING, TYPE B, INLAID, LINE 4" (WHITE 2' DASH, 6' SKIP) ⑪ PREFORMED PLASTIC PAVEMENT MARKING, TYPE B, INLAID, LINE 8" (WHITE 3' DASH, 9' SKIP) ⑫ PREFORMED PLASTIC PAVEMENT MARKING, TYPE B, INLAID, LINE 5" (WHITE 10' DASH, 30' SKIP) ⑬ POLYUREA PAVEMENT MARKING TYPE 1, LINE 4" (WHITE EDGE LINE) | <ul style="list-style-type: none"> ⑭ POLYUREA PAVEMENT MARKING TYPE 1, LINE 4" (YELLOW EDGE LINE) ⑮ POLYUREA PAVEMENT MARKING TYPE 1, LINE 8" (WHITE EDGE LINE) ⑯ POLYUREA PAVEMENT MARKING TYPE 1, LINE 5" (WHITE 10' DASH, 30' SKIP) ⑰ POLYUREA PAVEMENT MARKING TYPE 1, LINE 12" (WHITE GORE DIAGONALS SPACED @ 30' CENTERS) ⑱ RAISED REFLECTIVE PAVEMENT MARKER (1-WAY YELLOW / OPAQUE) ⑲ RAISED REFLECTIVE PAVEMENT MARKER (1-WAY CRYSTAL / OPAQUE) ⑳ THERMOPLASTIC PAVEMENT MARKING - LINE 12" (WHITE EDGE LINE) ㉑ THERMOPLASTIC PAVEMENT MARKING - LINE 6" (WHITE THRU LANE LINE) ㉒ POLYUREA PAVEMENT MARKING TYPE 1, LINE 12" (YELLOW DIAGONALS SPACED @ 500' CENTERS) ㉓ POLYUREA PAVEMENT MARKING TYPE 1, LINE 12" (WHITE DIAGONALS SPACED @ 500' CENTERS) ㉔ POLYUREA PAVEMENT MARKING TYPE 1, LETTERS AND SYMBOLS (WHITE) ㉕ POLYUREA PAVEMENT MARKING TYPE 1, LINE 8" (WHITE 3' DASH, 9' SKIP) ㉖ POLYUREA PAVEMENT MARKING TYPE 1, LINE 4" (WHITE 2' DASH, 6' SKIP) |
|--|--|

FILE NAME =	DESIGNED - AJP	REVISED -
...vprpln_ABC.C2.290.pvmtmkg_28.dgn	DRAWN - TMB	REVISED -
USER NAME = tbiork	CHECKED - JMM	REVISED -
PL07 DATE = 12/16/2009	DATE - 10/16/09	REVISED -

benesch

**STATE OF ILLINOIS
DEPARTMENT OF TRANSPORTATION**

**PAVEMENT MARKING PLANS
STA 803+00 TO STA 818+00**

SCALE: 1"=50' SHEET NO. 22 OF 31 SHEETS STA. TO STA.

F.A.I. RTE.	SECTION	COUNTY	TOTAL SHEETS	SHEET NO.
290	(3031.1, ETC., 3838)RS-5	COOK	298	212
FED. ROAD DIST. NO. ILLINOIS FED. AID PROJECT			CONTRACT NO. 60C52	

NOTE:

1. SEE IDOT DISTRICT 1 STANDARD TC-12 "MULTI-LANE FREEWAY PAVEMENT MARKING DETAILS" FOR PLACEMENT AND TYPE OF RAISED REFLECTIVE PAVEMENT MARKERS.
2. FOR PROPOSED PAVEMENT MARKINGS IN THE PCC SECTIONS USE POLYUREA PAVEMENT MARKINGS ACCORDING TO STANDARD TC-12.
3. REFER TO ROADWAY PLANS FOR LIMITS OF RESURFACING.

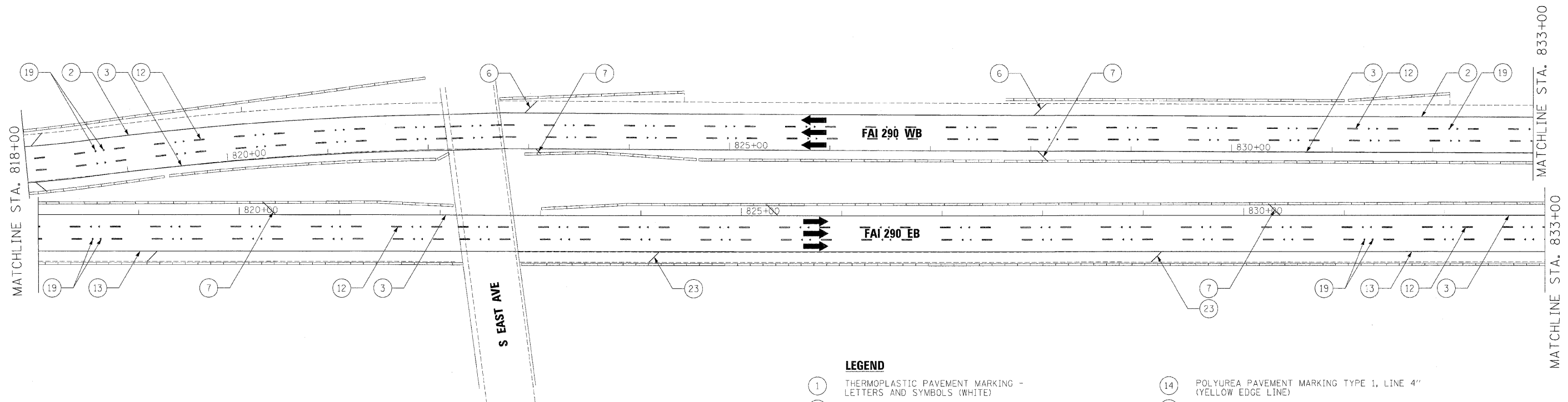

LEGEND

- | | |
|--|--|
| ① THERMOPLASTIC PAVEMENT MARKING - LETTERS AND SYMBOLS (WHITE) | ⑭ POLYUREA PAVEMENT MARKING TYPE 1, LINE 4" (YELLOW EDGE LINE) |
| ② THERMOPLASTIC PAVEMENT MARKING - LINE 4" (WHITE EDGE LINE) | ⑮ POLYUREA PAVEMENT MARKING TYPE 1, LINE 8" (WHITE EDGE LINE) |
| ③ THERMOPLASTIC PAVEMENT MARKING - LINE 4" (YELLOW EDGE LINE) | ⑯ POLYUREA PAVEMENT MARKING TYPE 1, LINE 5" (WHITE 10' DASH, 30' SKIP) |
| ④ THERMOPLASTIC PAVEMENT MARKING - LINE 8" (WHITE EDGE LINE) | ⑰ POLYUREA PAVEMENT MARKING TYPE 1, LINE 12" (WHITE GORE DIAGONALS SPACED @ 30' CENTERS) |
| ⑤ THERMOPLASTIC PAVEMENT MARKING - LINE 8" (WHITE DIAGONALS SPACED @ 10' CENTERS) | ⑱ RAISED REFLECTIVE PAVEMENT MARKER (1-WAY YELLOW / OPAQUE) |
| ⑥ THERMOPLASTIC PAVEMENT MARKING - LINE 12" (WHITE DIAGONALS SPACED @ 500' CENTERS) | ⑲ RAISED REFLECTIVE PAVEMENT MARKER (1-WAY CRYSTAL / OPAQUE) |
| ⑦ THERMOPLASTIC PAVEMENT MARKING - LINE 12" (YELLOW DIAGONALS SPACED @ 500' CENTERS) | ⑳ THERMOPLASTIC PAVEMENT MARKING - LINE 12" (WHITE EDGE LINE) |
| ⑧ THERMOPLASTIC PAVEMENT MARKING - LINE 12" (WHITE GORE DIAGONALS SPACED @ 30' CENTERS) | ㉑ THERMOPLASTIC PAVEMENT MARKING - LINE 6" (WHITE THRU LANE LINE) |
| ⑨ THERMOPLASTIC PAVEMENT MARKING - LINE 24" (WHITE) | ㉒ POLYUREA PAVEMENT MARKING TYPE 1, LINE 12" (YELLOW DIAGONALS SPACED @ 500' CENTERS) |
| ⑩ PREFORMED PLASTIC PAVEMENT MARKING, TYPE B, INLAID, LINE 4" (WHITE 2' DASH, 6' SKIP) | ㉓ POLYUREA PAVEMENT MARKING TYPE 1, LINE 12" (WHITE DIAGONALS SPACED @ 500' CENTERS) |
| ⑪ PREFORMED PLASTIC PAVEMENT MARKING, TYPE B, INLAID, LINE 8" (WHITE 3' DASH, 9' SKIP) | ㉔ POLYUREA PAVEMENT MARKING TYPE 1, LETTERS AND SYMBOLS (WHITE) |
| ⑫ PREFORMED PLASTIC PAVEMENT MARKING, TYPE B, INLAID, LINE 5" (WHITE 10' DASH, 30' SKIP) | ㉕ POLYUREA PAVEMENT MARKING TYPE 1, LINE 8" (WHITE 3' DASH, 9' SKIP) |
| ⑬ POLYUREA PAVEMENT MARKING TYPE 1, LINE 4" (WHITE EDGE LINE) | ㉖ POLYUREA PAVEMENT MARKING TYPE 1, LINE 4" (WHITE 2' DASH, 6' SKIP) |

FILE NAME =	DESIGNED - AJP	REVISED -
...NrpIn_ABC_C2_292_pvmtnkg_29.dgn	DRAWN - TMB	REVISED -
USER NAME = tblank	CHECKED - JMM	REVISED -
PLCT DATE = 12/16/2009	DATE - 10/16/09	REVISED -

benesch

**STATE OF ILLINOIS
DEPARTMENT OF TRANSPORTATION**

**PAVEMENT MARKING PLANS
STA 818+00 TO STA 833+00**

SCALE: 1"=50' SHEET NO. 23 OF 31 SHEETS STA. TO STA.

F.A.I. RTE.	SECTION	COUNTY	TOTAL SHEETS	SHEET NO.
290	(3031.1, ETC., 3838)RS-5	COOK	298	213
FED. ROAD DIST. NO. ILLINOIS FED. AID PROJECT			CONTRACT NO. 60G52	

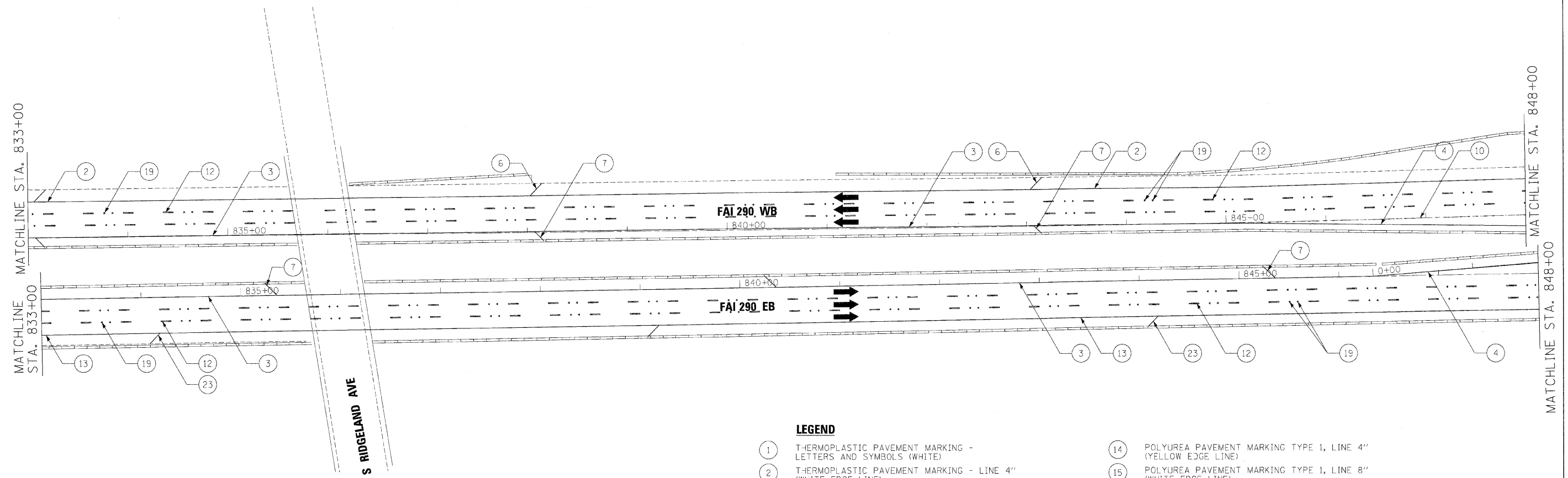

- NOTE:**
- SEE IDOT DISTRICT 1 STANDARD TC-12 "MULTI-LANE FREEWAY PAVEMENT MARKING DETAILS" FOR PLACEMENT AND TYPE OF RAISED REFLECTIVE PAVEMENT MARKERS.
 - FOR PROPOSED PAVEMENT MARKINGS IN THE PCC SECTIONS USE POLYUREA PAVEMENT MARKINGS ACCORDING TO STANDARD TC-12.
 - REFER TO ROADWAY PLANS FOR LIMITS OF RESURFACING.

- LEGEND**
- | | |
|--|--|
| ① THERMOPLASTIC PAVEMENT MARKING - LETTERS AND SYMBOLS (WHITE) | ⑭ POLYUREA PAVEMENT MARKING TYPE 1, LINE 4" (YELLOW EDGE LINE) |
| ② THERMOPLASTIC PAVEMENT MARKING - LINE 4" (WHITE EDGE LINE) | ⑮ POLYUREA PAVEMENT MARKING TYPE 1, LINE 8" (WHITE EDGE LINE) |
| ③ THERMOPLASTIC PAVEMENT MARKING - LINE 4" (YELLOW EDGE LINE) | ⑯ POLYUREA PAVEMENT MARKING TYPE 1, LINE 5" (WHITE 10' DASH, 30' SKIP) |
| ④ THERMOPLASTIC PAVEMENT MARKING - LINE 8" (WHITE EDGE LINE) | ⑰ POLYUREA PAVEMENT MARKING TYPE 1, LINE 12" (WHITE GORE DIAGONALS SPACED @ 30' CENTERS) |
| ⑤ THERMOPLASTIC PAVEMENT MARKING - LINE 8" (WHITE DIAGONALS SPACED @ 10' CENTERS) | ⑱ RAISED REFLECTIVE PAVEMENT MARKER (1-WAY YELLOW / OPAQUE) |
| ⑥ THERMOPLASTIC PAVEMENT MARKING - LINE 12" (WHITE DIAGONALS SPACED @ 500' CENTERS) | ⑲ RAISED REFLECTIVE PAVEMENT MARKER (1-WAY CRYSTAL / OPAQUE) |
| ⑦ THERMOPLASTIC PAVEMENT MARKING - LINE 12" (YELLOW DIAGONALS SPACED @ 500' CENTERS) | ⑳ THERMOPLASTIC PAVEMENT MARKING - LINE 12" (WHITE EDGE LINE) |
| ⑧ THERMOPLASTIC PAVEMENT MARKING - LINE 12" (WHITE GORE DIAGONALS SPACED @ 30' CENTERS) | ㉑ THERMOPLASTIC PAVEMENT MARKING - LINE 6" (WHITE THRU LANE LINE) |
| ⑨ THERMOPLASTIC PAVEMENT MARKING - LINE 24" (WHITE) | ㉒ POLYUREA PAVEMENT MARKING TYPE 1, LINE 12" (YELLOW DIAGONALS SPACED @ 500' CENTERS) |
| ⑩ PREFORMED PLASTIC PAVEMENT MARKING, TYPE B, INLAID, LINE 4" (WHITE 2' DASH, 6' SKIP) | ㉓ POLYUREA PAVEMENT MARKING TYPE 1, LINE 12" (WHITE DIAGONALS SPACED @ 500' CENTERS) |
| ⑪ PREFORMED PLASTIC PAVEMENT MARKING, TYPE B, INLAID, LINE 8" (WHITE 3' DASH, 9' SKIP) | ㉔ POLYUREA PAVEMENT MARKING TYPE 1, LETTERS AND SYMBOLS (WHITE) |
| ⑫ PREFORMED PLASTIC PAVEMENT MARKING, TYPE B, INLAID, LINE 5" (WHITE 10' DASH, 30' SKIP) | ㉕ POLYUREA PAVEMENT MARKING TYPE 1, LINE 8" (WHITE 3' DASH, 9' SKIP) |
| ⑬ POLYUREA PAVEMENT MARKING TYPE 1, LINE 4" (WHITE EDGE LINE) | ㉖ POLYUREA PAVEMENT MARKING TYPE 1, LINE 4" (WHITE 2' DASH, 6' SKIP) |

FILE NAME =	DESIGNED - AJP	REVISED -
...prpln_A3C_C2_290_pvmmsg_30.dgn	DRAWN - TMB	REVISED -
USER NAME = tblank	CHECKED - JMM	REVISED -
PLOT DATE = 12/15/2009	DATE - 10/16/09	REVISED -

benesch

**STATE OF ILLINOIS
DEPARTMENT OF TRANSPORTATION**

**PAVEMENT MARKING PLANS
STA 833+00 TO STA 848+00**

SCALE: 1"=50' SHEET NO. 24 OF 31 SHEETS STA. TO STA.

F.A.I. RTE.	SECTION	COUNTY	TOTAL SHEETS	SHEET NO.
290	(3031.1, ETC., 3838IRS-5)	COOK	298	214
FED. ROAD DIST. NO.			ILLINOIS FED. AID PROJECT	
			CONTRACT NO. 60G52	

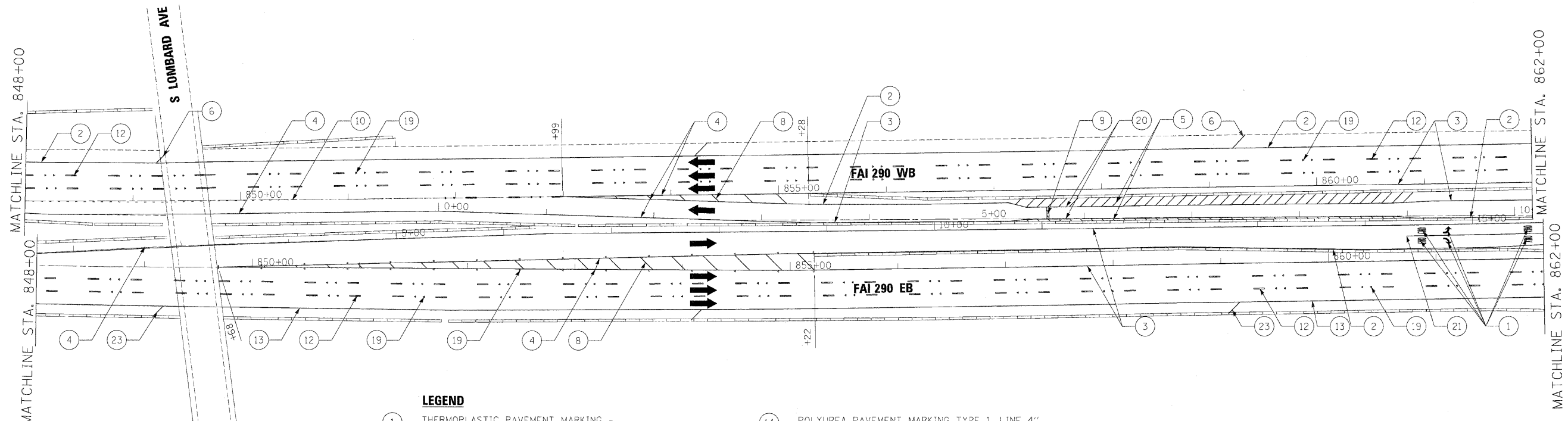

LEGEND

- | | |
|--|--|
| <ul style="list-style-type: none"> ① THERMOPLASTIC PAVEMENT MARKING - LETTERS AND SYMBOLS (WHITE) ② THERMOPLASTIC PAVEMENT MARKING - LINE 4" (WHITE EDGE LINE) ③ THERMOPLASTIC PAVEMENT MARKING - LINE 4" (YELLOW EDGE LINE) ④ THERMOPLASTIC PAVEMENT MARKING - LINE 8" (WHITE EDGE LINE) ⑤ THERMOPLASTIC PAVEMENT MARKING - LINE 8" (WHITE DIAGONALS SPACED @ 10' CENTERS) ⑥ THERMOPLASTIC PAVEMENT MARKING - LINE 12" (WHITE DIAGONALS SPACED @ 500' CENTERS) ⑦ THERMOPLASTIC PAVEMENT MARKING - LINE 12" (YELLOW DIAGONALS SPACED @ 500' CENTERS) ⑧ THERMOPLASTIC PAVEMENT MARKING - LINE 12" (WHITE GORE DIAGONALS SPACED @ 30' CENTERS) ⑨ THERMOPLASTIC PAVEMENT MARKING - LINE 24" (WHITE) ⑩ PREFORMED PLASTIC PAVEMENT MARKING, TYPE B, INLAID, LINE 4" (WHITE 2' DASH, 6' SKIP) ⑪ PREFORMED PLASTIC PAVEMENT MARKING, TYPE B, INLAID, LINE 8" (WHITE 3' DASH, 9' SKIP) ⑫ PREFORMED PLASTIC PAVEMENT MARKING, TYPE B, INLAID, LINE 5" (WHITE 10' DASH, 30' SKIP) ⑬ POLYUREA PAVEMENT MARKING TYPE 1, LINE 4" (WHITE EDGE LINE) | <ul style="list-style-type: none"> ⑭ POLYUREA PAVEMENT MARKING TYPE 1, LINE 4" (YELLOW EDGE LINE) ⑮ POLYUREA PAVEMENT MARKING TYPE 1, LINE 8" (WHITE EDGE LINE) ⑯ POLYUREA PAVEMENT MARKING TYPE 1, LINE 5" (WHITE 10' DASH, 30' SKIP) ⑰ POLYUREA PAVEMENT MARKING TYPE 1, LINE 12" (WHITE GORE DIAGONALS SPACED @ 30' CENTERS) ⑱ RAISED REFLECTIVE PAVEMENT MARKER (1-WAY YELLOW / OPAQUE) ⑲ RAISED REFLECTIVE PAVEMENT MARKER (1-WAY CRYSTAL / OPAQUE) ⑳ THERMOPLASTIC PAVEMENT MARKING - LINE 12" (WHITE EDGE LINE) ㉑ THERMOPLASTIC PAVEMENT MARKING - LINE 6" (WHITE THRU LANE LINE) ㉒ POLYUREA PAVEMENT MARKING TYPE 1, LINE 12" (YELLOW DIAGONALS SPACED @ 500' CENTERS) ㉓ POLYUREA PAVEMENT MARKING TYPE 1, LINE 12" (WHITE DIAGONALS SPACED @ 500' CENTERS) ㉔ POLYUREA PAVEMENT MARKING TYPE 1, LETTERS AND SYMBOLS (WHITE) ㉕ POLYUREA PAVEMENT MARKING TYPE 1, LINE 8" (WHITE 3' DASH, 9' SKIP) ㉖ POLYUREA PAVEMENT MARKING TYPE 1, LINE 4" (WHITE 2' DASH, 6' SKIP) |
|--|--|

NOTE:

1. SEE IDOT DISTRICT 1 STANDARD TC-12 "MULTI-LANE FREEWAY PAVEMENT MARKING DETAILS" FOR PLACEMENT AND TYPE OF RAISED REFLECTIVE PAVEMENT MARKERS.
2. FOR PROPOSED PAVEMENT MARKINGS IN THE PCC SECTIONS USE POLYUREA PAVEMENT MARKINGS ACCORDING TO STANDARD TC-12.
3. REFER TO ROADWAY PLANS FOR LIMITS OF RESURFACING.

FILE NAME =	DESIGNED - AJP	REVISED -	benesch	STATE OF ILLINOIS DEPARTMENT OF TRANSPORTATION	PAVEMENT MARKING PLANS STA 848+00 TO STA 862+00			F.A.I. RTE.	SECTION	COUNTY	TOTAL SHEETS	SHEET NO.	
...\\prp\In_ABC.C2.290.pvmstnkg_31.dgn	DRAWN - TMB	REVISED -			290	(3031.1, ETC., 3838)RS-5	COOK	298	215				
USER NAME = tbiork	CHECKED - JMM	REVISED -			SCALE: 1"=50'			SHEET NO. 25 OF 31 SHEETS		STA. TO STA.		CONTRACT NO. 60G52	
PLOT DATE = 12/16/2009	DATE - 10/16/09	REVISED -			FED. ROAD DIST. NO.		ILLINOIS		FED. AID PROJECT				

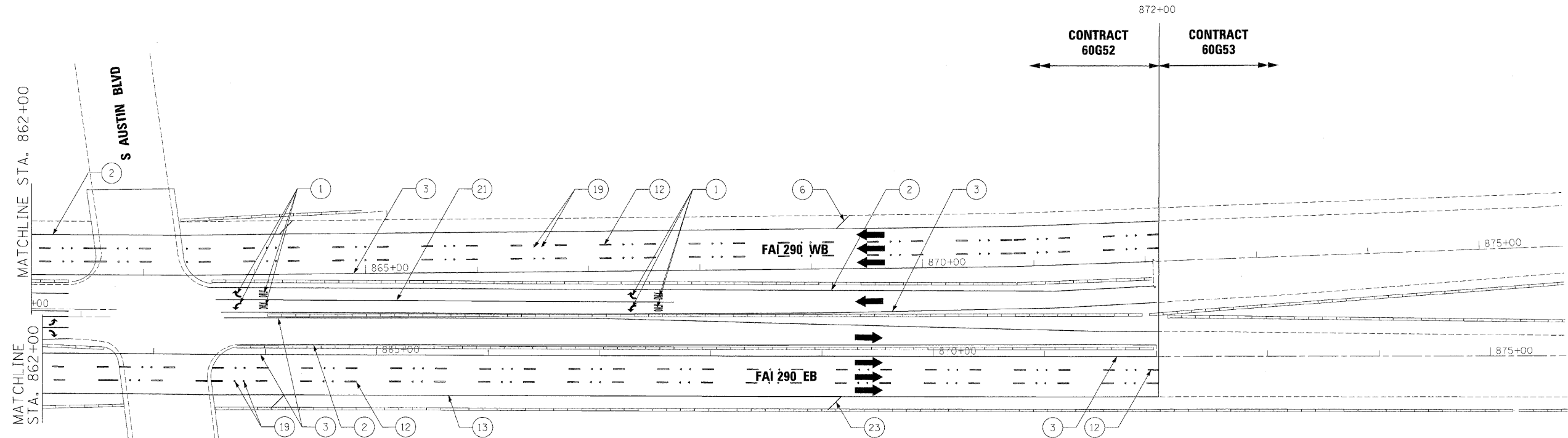

LEGEND

- | | |
|--|--|
| <ul style="list-style-type: none"> ① THERMOPLASTIC PAVEMENT MARKING - LETTERS AND SYMBOLS (WHITE) ② THERMOPLASTIC PAVEMENT MARKING - LINE 4" (WHITE EDGE LINE) ③ THERMOPLASTIC PAVEMENT MARKING - LINE 4" (YELLOW EDGE LINE) ④ THERMOPLASTIC PAVEMENT MARKING - LINE 8" (WHITE EDGE LINE) ⑤ THERMOPLASTIC PAVEMENT MARKING - LINE 8" (WHITE DIAGONALS SPACED @ 10' CENTERS) ⑥ THERMOPLASTIC PAVEMENT MARKING - LINE 12" (WHITE DIAGONALS SPACED @ 500' CENTERS) ⑦ THERMOPLASTIC PAVEMENT MARKING - LINE 12" (YELLOW DIAGONALS SPACED @ 500' CENTERS) ⑧ THERMOPLASTIC PAVEMENT MARKING - LINE 12" (WHITE GORE DIAGONALS SPACED @ 30' CENTERS) ⑨ THERMOPLASTIC PAVEMENT MARKING - LINE 24" (WHITE) ⑩ PREFORMED PLASTIC PAVEMENT MARKING, TYPE B, INLAID, LINE 4" (WHITE 2' DASH, 6' SKIP) ⑪ PREFORMED PLASTIC PAVEMENT MARKING, TYPE B, INLAID, LINE 8" (WHITE 3' DASH, 9' SKIP) ⑫ PREFORMED PLASTIC PAVEMENT MARKING, TYPE B, INLAID, LINE 5" (WHITE 10' DASH, 30' SKIP) ⑬ POLYUREA PAVEMENT MARKING TYPE 1, LINE 4" (WHITE EDGE LINE) | <ul style="list-style-type: none"> ⑭ POLYUREA PAVEMENT MARKING TYPE 1, LINE 4" (YELLOW EDGE LINE) ⑮ POLYUREA PAVEMENT MARKING TYPE 1, LINE 8" (WHITE EDGE LINE) ⑯ POLYUREA PAVEMENT MARKING TYPE 1, LINE 5" (WHITE 10' DASH, 30' SKIP) ⑰ POLYUREA PAVEMENT MARKING TYPE 1, LINE 12" (WHITE GORE DIAGONALS SPACED @ 30' CENTERS) ⑱ RAISED REFLECTIVE PAVEMENT MARKER (1-WAY YELLOW / OPAQUE) ⑲ RAISED REFLECTIVE PAVEMENT MARKER (1-WAY CRYSTAL / OPAQUE) ⑳ THERMOPLASTIC PAVEMENT MARKING - LINE 12" (WHITE EDGE LINE) ㉑ THERMOPLASTIC PAVEMENT MARKING - LINE 6" (WHITE THRU LANE LINE) ㉒ POLYUREA PAVEMENT MARKING TYPE 1, LINE 12" (YELLOW DIAGONALS SPACED @ 500' CENTERS) ㉓ POLYUREA PAVEMENT MARKING TYPE 1, LINE 12" (WHITE DIAGONALS SPACED @ 500' CENTERS) ㉔ POLYUREA PAVEMENT MARKING TYPE 1, LETTERS AND SYMBOLS (WHITE) ㉕ POLYUREA PAVEMENT MARKING TYPE 1, LINE 8" (WHITE 3' DASH, 9' SKIP) ㉖ POLYUREA PAVEMENT MARKING TYPE 1, LINE 4" (WHITE 2' DASH, 6' SKIP) |
|--|--|

NOTE:

1. SEE IDOT DISTRICT 1 STANDARD TC-12 "MULTI-LANE FREEWAY PAVEMENT MARKING DETAILS" FOR PLACEMENT AND TYPE OF RAISED REFLECTIVE PAVEMENT MARKERS.
2. FOR PROPOSED PAVEMENT MARKINGS IN THE PCC SECTIONS USE POLYUREA PAVEMENT MARKINGS ACCORDING TO STANDARD TC-12.
3. REFER TO ROADWAY PLANS FOR LIMITS OF RESURFACING.

FILE NAME =	DESIGNED - AJP	REVISED -
...\\prpln_abc_c2_290_pvm\mkg_32.dgn	DRAWN - TMB	REVISED -
USER NAME = tblank	CHECKED - JMM	REVISED -
PLOT DATE = 12/16/2009	DATE - 10/16/09	REVISED -

benesch

**STATE OF ILLINOIS
DEPARTMENT OF TRANSPORTATION**

**PAVEMENT MARKING PLANS
STA 862+00 TO P.O.E.**

SCALE: 1"=50' SHEET NO. 26 OF 31 SHEETS STA. TO STA.

F.A.I. RTE.	SECTION	COUNTY	TOTAL SHEETS	SHEET NO.
290	(3031.1, ETC., 3838)RS-5	COOK	298	216
FED. ROAD DIST. NO. ILLINOIS FED. AID PROJECT			CONTRACT NO. 60G52	

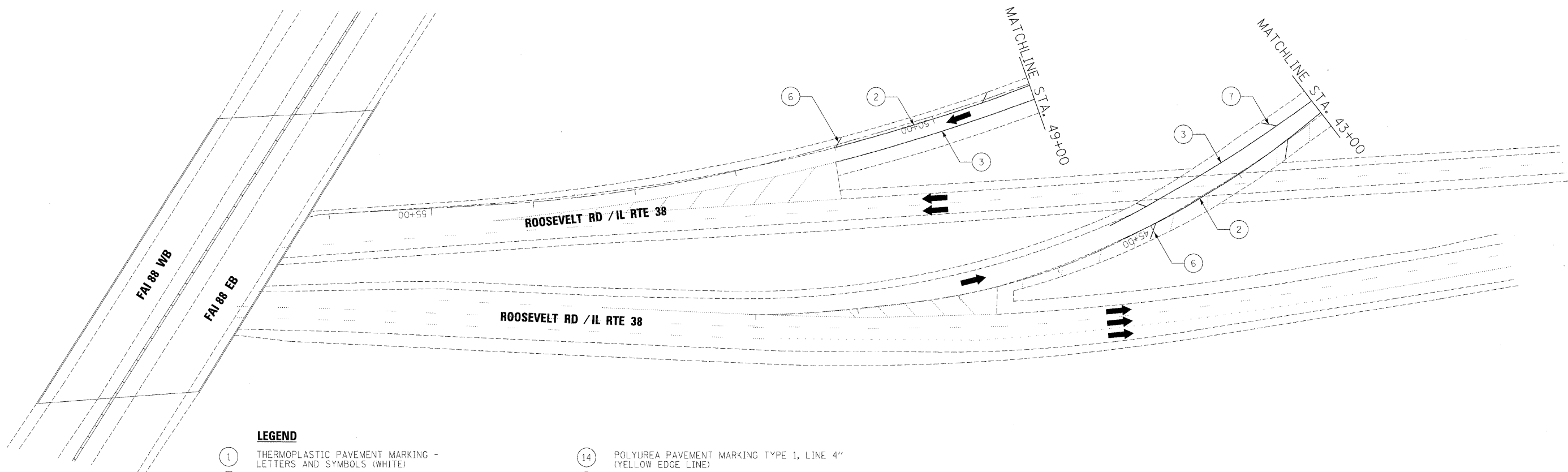

LEGEND

- | | |
|--|--|
| <ul style="list-style-type: none"> ① THERMOPLASTIC PAVEMENT MARKING - LETTERS AND SYMBOLS (WHITE) ② THERMOPLASTIC PAVEMENT MARKING - LINE 4" (WHITE EDGE LINE) ③ THERMOPLASTIC PAVEMENT MARKING - LINE 4" (YELLOW EDGE LINE) ④ THERMOPLASTIC PAVEMENT MARKING - LINE 8" (WHITE EDGE LINE) ⑤ THERMOPLASTIC PAVEMENT MARKING - LINE 8" (WHITE DIAGONALS SPACED @ 10' CENTERS) ⑥ THERMOPLASTIC PAVEMENT MARKING - LINE 12" (WHITE DIAGONALS SPACED @ 500' CENTERS) ⑦ THERMOPLASTIC PAVEMENT MARKING - LINE 12" (YELLOW DIAGONALS SPACED @ 500' CENTERS) ⑧ THERMOPLASTIC PAVEMENT MARKING - LINE 12" (WHITE GORE DIAGONALS SPACED @ 30' CENTERS) ⑨ THERMOPLASTIC PAVEMENT MARKING - LINE 24" (WHITE) ⑩ PREFORMED PLASTIC PAVEMENT MARKING, TYPE B, INLAID, LINE 4" (WHITE 2' DASH, 6' SKIP) ⑪ PREFORMED PLASTIC PAVEMENT MARKING, TYPE B, INLAID, LINE 8" (WHITE 3' DASH, 9' SKIP) ⑫ PREFORMED PLASTIC PAVEMENT MARKING, TYPE B, INLAID, LINE 5" (WHITE 10' DASH, 30' SKIP) ⑬ POLYUREA PAVEMENT MARKING TYPE 1, LINE 4" (WHITE EDGE LINE) | <ul style="list-style-type: none"> ⑭ POLYUREA PAVEMENT MARKING TYPE 1, LINE 4" (YELLOW EDGE LINE) ⑮ POLYUREA PAVEMENT MARKING TYPE 1, LINE 8" (WHITE EDGE LINE) ⑯ POLYUREA PAVEMENT MARKING TYPE 1, LINE 5" (WHITE 10' DASH, 30' SKIP) ⑰ POLYUREA PAVEMENT MARKING TYPE 1, LINE 12" (WHITE GORE DIAGONALS SPACED @ 30' CENTERS) ⑱ RAISED REFLECTIVE PAVEMENT MARKER (1-WAY YELLOW / OPAQUE) ⑲ RAISED REFLECTIVE PAVEMENT MARKER (1-WAY CRYSTAL / OPAQUE) ⑳ THERMOPLASTIC PAVEMENT MARKING - LINE 12" (WHITE EDGE LINE) ㉑ THERMOPLASTIC PAVEMENT MARKING - LINE 6" (WHITE THRU LANE LINE) ㉒ POLYUREA PAVEMENT MARKING TYPE 1, LINE 12" (YELLOW DIAGONALS SPACED @ 500' CENTERS) ㉓ POLYUREA PAVEMENT MARKING TYPE 1, LINE 12" (WHITE DIAGONALS SPACED @ 500' CENTERS) ㉔ POLYUREA PAVEMENT MARKING TYPE 1, LETTERS AND SYMBOLS (WHITE) ㉕ POLYUREA PAVEMENT MARKING TYPE 1, LINE 8" (WHITE 3' DASH, 9' SKIP) ㉖ POLYUREA PAVEMENT MARKING TYPE 1, LINE 4" (WHITE 2' DASH, 6' SKIP) |
|--|--|

NOTE:

1. SEE IDOT DISTRICT 1 STANDARD TC-12 "MULTI-LANE FREEWAY PAVEMENT MARKING DETAILS" FOR PLACEMENT AND TYPE OF RAISED REFLECTIVE PAVEMENT MARKERS.
2. FOR PROPOSED PAVEMENT MARKINGS IN THE PCC SECTIONS USE POLYUREA PAVEMENT MARKINGS ACCORDING TO STANDARD TC-12.
3. REFER TO ROADWAY PLANS FOR LIMITS OF RESURFACING.

FILE NAME =	DESIGNED - AJP	REVISED -
...NppIn_ABC_C2_38.pvmtmkg_01.dgn	DRAWN - TMB	REVISED -
USER NAME = tbiark	CHECKED - JMM	REVISED -
PLOT DATE = 12/15/2009	DATE - 10/16/09	REVISED -



**STATE OF ILLINOIS
DEPARTMENT OF TRANSPORTATION**

PAVEMENT MARKING PLANS ROOSEVELT ROAD / IL RTE 38	
SCALE: 1"=50'	SHEET NO. 27 OF 31 SHEETS
STA. _____	TO STA. _____

F.A.I. RTE.	SECTION	COUNTY	TOTAL SHEETS	SHEET NO.
290	(3031.1, ETC., 3838)RS-5	COOK	298	217
FED. ROAD DIST. NO.			ILLINOIS FED. AID PROJECT	
CONTRACT NO. 60G52				

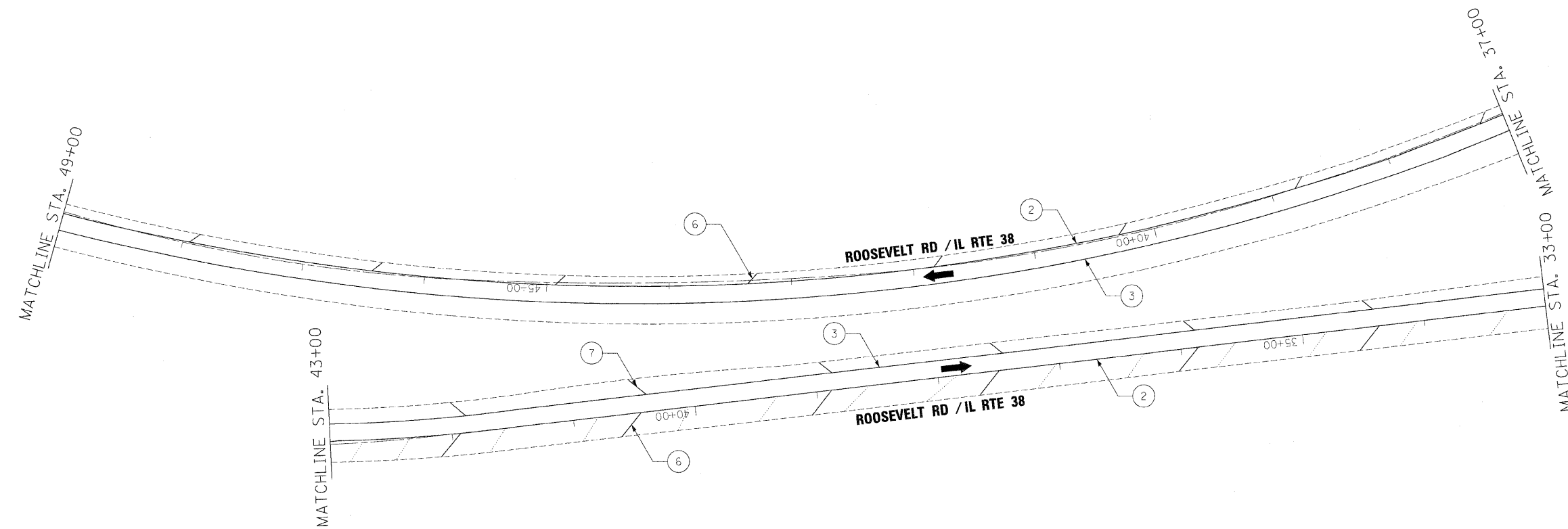
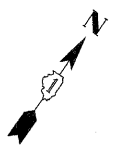

LEGEND

- | | |
|--|--|
| <ul style="list-style-type: none"> ① THERMOPLASTIC PAVEMENT MARKING - LETTERS AND SYMBOLS (WHITE) ② THERMOPLASTIC PAVEMENT MARKING - LINE 4" (WHITE EDGE LINE) ③ THERMOPLASTIC PAVEMENT MARKING - LINE 4" (YELLOW EDGE LINE) ④ THERMOPLASTIC PAVEMENT MARKING - LINE 8" (WHITE EDGE LINE) ⑤ THERMOPLASTIC PAVEMENT MARKING - LINE 8" (WHITE DIAGONALS SPACED @ 10' CENTERS) ⑥ THERMOPLASTIC PAVEMENT MARKING - LINE 12" (WHITE DIAGONALS SPACED @ 500' CENTERS) ⑦ THERMOPLASTIC PAVEMENT MARKING - LINE 12" (YELLOW DIAGONALS SPACED @ 500' CENTERS) ⑧ THERMOPLASTIC PAVEMENT MARKING - LINE 12" (WHITE GORE DIAGONALS SPACED @ 30' CENTERS) ⑨ THERMOPLASTIC PAVEMENT MARKING - LINE 24" (WHITE) ⑩ PREFORMED PLASTIC PAVEMENT MARKING, TYPE B, INLAID, LINE 4" (WHITE 2' DASH, 6' SKIP) ⑪ PREFORMED PLASTIC PAVEMENT MARKING, TYPE B, INLAID, LINE 8" (WHITE 3' DASH, 9' SKIP) ⑫ PREFORMED PLASTIC PAVEMENT MARKING, TYPE B, INLAID, LINE 5" (WHITE 10' DASH, 30' SKIP) ⑬ POLYUREA PAVEMENT MARKING TYPE 1, LINE 4" (WHITE EDGE LINE) | <ul style="list-style-type: none"> ⑭ POLYUREA PAVEMENT MARKING TYPE 1, LINE 4" (YELLOW EDGE LINE) ⑮ POLYUREA PAVEMENT MARKING TYPE 1, LINE 8" (WHITE EDGE LINE) ⑯ POLYUREA PAVEMENT MARKING TYPE 1, LINE 5" (WHITE 10' DASH, 30' SKIP) ⑰ POLYUREA PAVEMENT MARKING TYPE 1, LINE 12" (WHITE GORE DIAGONALS SPACED @ 30' CENTERS) ⑱ RAISED REFLECTIVE PAVEMENT MARKER (1-WAY YELLOW / OPAQUE) ⑲ RAISED REFLECTIVE PAVEMENT MARKER (1-WAY CRYSTAL / OPAQUE) ⑳ THERMOPLASTIC PAVEMENT MARKING - LINE 12" (WHITE EDGE LINE) ㉑ THERMOPLASTIC PAVEMENT MARKING - LINE 6" (WHITE THRU LANE LINE) ㉒ POLYUREA PAVEMENT MARKING TYPE 1, LINE 12" (YELLOW DIAGONALS SPACED @ 500' CENTERS) ㉓ POLYUREA PAVEMENT MARKING TYPE 1, LINE 12" (WHITE DIAGONALS SPACED @ 500' CENTERS) ㉔ POLYUREA PAVEMENT MARKING TYPE 1, LETTERS AND SYMBOLS (WHITE) ㉕ POLYUREA PAVEMENT MARKING TYPE 1, LINE 8" (WHITE 3' DASH, 9' SKIP) ㉖ POLYUREA PAVEMENT MARKING TYPE 1, LINE 4" (WHITE 2' DASH, 6' SKIP) |
|--|--|

NOTE:

1. SEE IDOT DISTRICT 1 STANDARD TC-12 "MULTI-LANE FREEWAY PAVEMENT MARKING DETAILS" FOR PLACEMENT AND TYPE OF RAISED REFLECTIVE PAVEMENT MARKERS.
2. FOR PROPOSED PAVEMENT MARKINGS IN THE PCC SECTIONS USE POLYUREA PAVEMENT MARKINGS ACCORDING TO STANDARD TC-12.
3. REFER TO ROADWAY PLANS FOR LIMITS OF RESURFACING.

FILE NAME =	DESIGNED -	REVISED -
...\\p\in.ABC.C2.138.pvmtmkg.02.dgn	DRAWN - TMB	REVISED -
USER NAME = tblank	CHECKED - JMM	REVISED -
PLOT DATE = 12/16/2009	DATE - 10/16/09	REVISED -

benesch

**STATE OF ILLINOIS
DEPARTMENT OF TRANSPORTATION**

**PAVEMENT MARKING PLANS
ROOSEVELT ROAD / IL RTE 38**

SCALE: 1"=50' SHEET NO. 28 OF 31 SHEETS STA. TO STA.

F.A.I. RTE.	SECTION	COUNTY	TOTAL SHEETS	SHEET NO.
290	(3031.1, ETC., 3838)RS-5	COOK	298	218
FED. ROAD DIST. NO. ILLINOIS FED. AID PROJECT			CONTRACT NO. 60652	

LEGEND

- ① THERMOPLASTIC PAVEMENT MARKING - LETTERS AND SYMBOLS (WHITE)
- ② THERMOPLASTIC PAVEMENT MARKING - LINE 4" (WHITE EDGE LINE)
- ③ THERMOPLASTIC PAVEMENT MARKING - LINE 4" (YELLOW EDGE LINE)
- ④ THERMOPLASTIC PAVEMENT MARKING - LINE 8" (WHITE EDGE LINE)
- ⑤ THERMOPLASTIC PAVEMENT MARKING - LINE 8" (WHITE DIAGONALS SPACED @ 10' CENTERS)
- ⑥ THERMOPLASTIC PAVEMENT MARKING - LINE 12" (WHITE DIAGONALS SPACED @ 500' CENTERS)
- ⑦ THERMOPLASTIC PAVEMENT MARKING - LINE 12" (YELLOW DIAGONALS SPACED @ 500' CENTERS)
- ⑧ THERMOPLASTIC PAVEMENT MARKING - LINE 12" (WHITE GORE DIAGONALS SPACED @ 30' CENTERS)
- ⑨ THERMOPLASTIC PAVEMENT MARKING - LINE 24" (WHITE)
- ⑩ PREFORMED PLASTIC PAVEMENT MARKING, TYPE B, INLAID, LINE 4" (WHITE 2' DASH, 6" SKIP)
- ⑪ PREFORMED PLASTIC PAVEMENT MARKING, TYPE B, INLAID, LINE 8" (WHITE 3' DASH, 9" SKIP)
- ⑫ PREFORMED PLASTIC PAVEMENT MARKING, TYPE B, INLAID, LINE 5" (WHITE 10' DASH, 30' SKIP)
- ⑬ POLYUREA PAVEMENT MARKING TYPE 1, LINE 4" (WHITE EDGE LINE)
- ⑭ POLYUREA PAVEMENT MARKING TYPE 1, LINE 4" (YELLOW EDGE LINE)
- ⑮ POLYUREA PAVEMENT MARKING TYPE 1, LINE 8" (WHITE EDGE LINE)
- ⑯ POLYUREA PAVEMENT MARKING TYPE 1, LINE 5" (WHITE 10' DASH, 30' SKIP)
- ⑰ POLYUREA PAVEMENT MARKING TYPE 1, LINE 12" (WHITE GORE DIAGONALS SPACED @ 30' CENTERS)
- ⑱ RAISED REFLECTIVE PAVEMENT MARKER (1-WAY YELLOW / OPAQUE)
- ⑲ RAISED REFLECTIVE PAVEMENT MARKER (1-WAY CRYSTAL / OPAQUE)
- ⑳ THERMOPLASTIC PAVEMENT MARKING - LINE 12" (WHITE EDGE LINE)
- ㉑ THERMOPLASTIC PAVEMENT MARKING - LINE 6" (WHITE THRU LANE LINE)
- ㉒ POLYUREA PAVEMENT MARKING TYPE 1, LINE 12" (YELLOW DIAGONALS SPACED @ 500' CENTERS)
- ㉓ POLYUREA PAVEMENT MARKING TYPE 1, LINE 12" (WHITE DIAGONALS SPACED @ 500' CENTERS)
- ㉔ POLYUREA PAVEMENT MARKING TYPE 1, LETTERS AND SYMBOLS (WHITE)
- ㉕ POLYUREA PAVEMENT MARKING TYPE 1, LINE 8" (WHITE 3' DASH, 9' SKIP)
- ㉖ POLYUREA PAVEMENT MARKING TYPE 1, LINE 4" (WHITE 2' DASH, 6' SKIP)

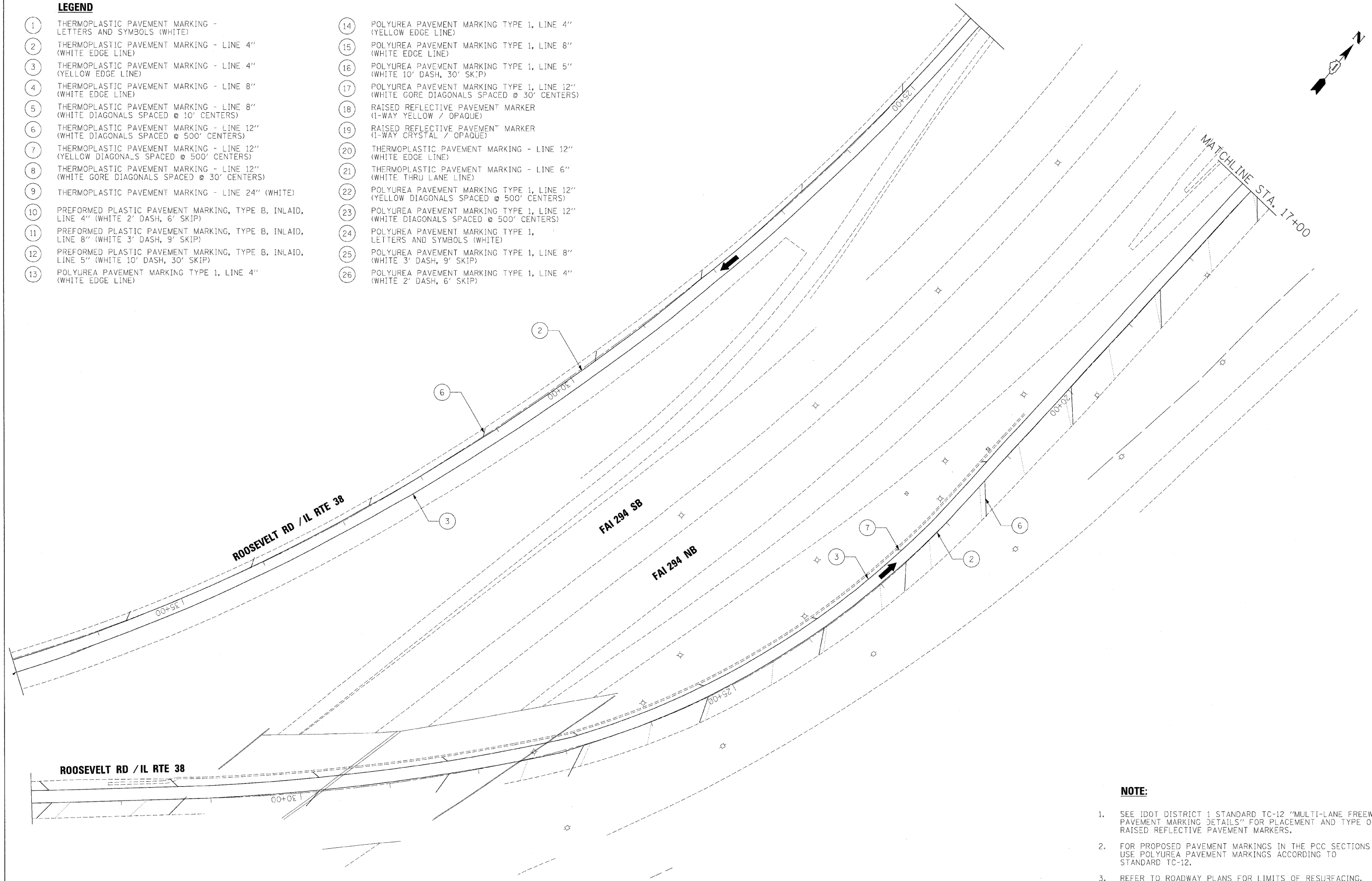
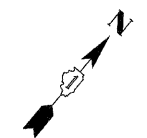

NOTE:

1. SEE IDOT DISTRICT 1 STANDARD TC-12 "MULTI-LANE FREEWAY PAVEMENT MARKING DETAILS" FOR PLACEMENT AND TYPE OF RAISED REFLECTIVE PAVEMENT MARKERS.
2. FOR PROPOSED PAVEMENT MARKINGS IN THE PCC SECTIONS USE POLYUREA PAVEMENT MARKINGS ACCORDING TO STANDARD TC-12.
3. REFER TO ROADWAY PLANS FOR LIMITS OF RESURFACING.

FILE NAME =	DESIGNED - AJP	REVISED -
...NorpIn_ABC_C2_138L_pvmtrkg_03.dgn	DRAWN - TMB	REVISED -
USER NAME = tblank	CHECKED - JMM	REVISED -
PLOT DATE = 12/16/2009	DATE - 10/16/09	REVISED -

benesch

**STATE OF ILLINOIS
DEPARTMENT OF TRANSPORTATION**

**PAVEMENT MARKING PLANS
ROOSEVELT ROAD / IL RTE 38**

SCALE: 1"=50' SHEET NO. 29 OF 31 SHEETS STA. TO STA.

F.A.I. RTE.	SECTION	COUNTY	TOTAL SHEETS	SHEET NO.
290	(3031.1, ETC., 3838)RS-5	COOK	298	219
FED. ROAD DIST. NO.			ILLINOIS FED. AID PROJECT	
			CONTRACT NO. 60G52	

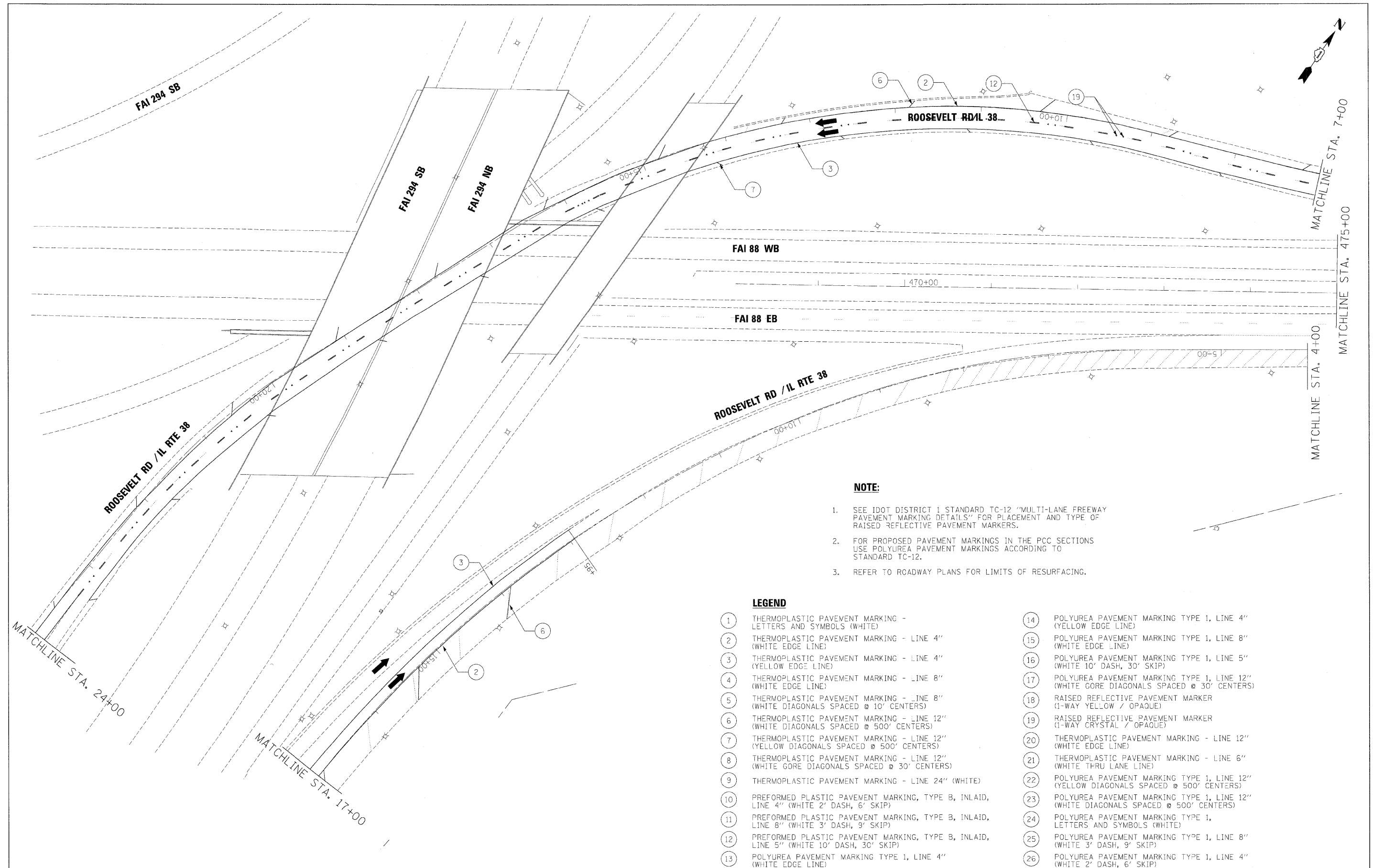

NOTE:

1. SEE IDOT DISTRICT 1 STANDARD TC-12 "MULTI-LANE FREEWAY PAVEMENT MARKING DETAILS" FOR PLACEMENT AND TYPE OF RAISED REFLECTIVE PAVEMENT MARKERS.
2. FOR PROPOSED PAVEMENT MARKINGS IN THE PCC SECTIONS USE POLYUREA PAVEMENT MARKINGS ACCORDING TO STANDARD TC-12.
3. REFER TO ROADWAY PLANS FOR LIMITS OF RESURFACING.

LEGEND

- | | |
|--|--|
| <ul style="list-style-type: none"> ① THERMOPLASTIC PAVEMENT MARKING - LETTERS AND SYMBOLS (WHITE) ② THERMOPLASTIC PAVEMENT MARKING - LINE 4" (WHITE EDGE LINE) ③ THERMOPLASTIC PAVEMENT MARKING - LINE 4" (YELLOW EDGE LINE) ④ THERMOPLASTIC PAVEMENT MARKING - LINE 8" (WHITE EDGE LINE) ⑤ THERMOPLASTIC PAVEMENT MARKING - LINE 8" (WHITE DIAGONALS SPACED @ 10' CENTERS) ⑥ THERMOPLASTIC PAVEMENT MARKING - LINE 12" (WHITE DIAGONALS SPACED @ 500' CENTERS) ⑦ THERMOPLASTIC PAVEMENT MARKING - LINE 12" (YELLOW DIAGONALS SPACED @ 500' CENTERS) ⑧ THERMOPLASTIC PAVEMENT MARKING - LINE 12" (WHITE GORE DIAGONALS SPACED @ 30' CENTERS) ⑨ THERMOPLASTIC PAVEMENT MARKING - LINE 24" (WHITE) ⑩ PREFORMED PLASTIC PAVEMENT MARKING, TYPE B, INLAID, LINE 4" (WHITE 2' DASH, 6' SKIP) ⑪ PREFORMED PLASTIC PAVEMENT MARKING, TYPE B, INLAID, LINE 6" (WHITE 3' DASH, 9' SKIP) ⑫ PREFORMED PLASTIC PAVEMENT MARKING, TYPE B, INLAID, LINE 5" (WHITE 10' DASH, 30' SKIP) ⑬ POLYUREA PAVEMENT MARKING TYPE 1, LINE 4" (WHITE EDGE LINE) | <ul style="list-style-type: none"> ⑭ POLYUREA PAVEMENT MARKING TYPE 1, LINE 4" (YELLOW EDGE LINE) ⑮ POLYUREA PAVEMENT MARKING TYPE 1, LINE 8" (WHITE EDGE LINE) ⑯ POLYUREA PAVEMENT MARKING TYPE 1, LINE 5" (WHITE 10' DASH, 30' SKIP) ⑰ POLYUREA PAVEMENT MARKING TYPE 1, LINE 12" (WHITE GORE DIAGONALS SPACED @ 30' CENTERS) ⑱ RAISED REFLECTIVE PAVEMENT MARKER (1-WAY YELLOW / OPAQUE) ⑲ RAISED REFLECTIVE PAVEMENT MARKER (1-WAY CRYSTAL / OPAQUE) ⑳ THERMOPLASTIC PAVEMENT MARKING - LINE 12" (WHITE EDGE LINE) ㉑ THERMOPLASTIC PAVEMENT MARKING - LINE 6" (WHITE THRU LANE LINE) ㉒ POLYUREA PAVEMENT MARKING TYPE 1, LINE 12" (YELLOW DIAGONALS SPACED @ 500' CENTERS) ㉓ POLYUREA PAVEMENT MARKING TYPE 1, LINE 12" (WHITE DIAGONALS SPACED @ 500' CENTERS) ㉔ POLYUREA PAVEMENT MARKING TYPE 1, LETTERS AND SYMBOLS (WHITE) ㉕ POLYUREA PAVEMENT MARKING TYPE 1, LINE 8" (WHITE 3' DASH, 9' SKIP) ㉖ POLYUREA PAVEMENT MARKING TYPE 1, LINE 4" (WHITE 2' DASH, 6' SKIP) |
|--|--|

FILE NAME =	DESIGNED - AJP	REVISED -
...NppLn.ABC 02 138 pvmrknk.04.dgn	DRAWN - TMB	REVISED -
USER NAME = tblank	CHECKED - JMM	REVISED -
PLOT DATE = 12/16/2009	DATE - 10/16/09	REVISED -

benesch

**STATE OF ILLINOIS
DEPARTMENT OF TRANSPORTATION**

**PAVEMENT MARKING PLANS
ROOSEVELT ROAD / IL RTE 38**

SCALE: 1"=50' SHEET NO. 30 OF 31 SHEETS STA. TO STA.

F.A.I. RTE.	SECTION	COUNTY	TOTAL SHEETS	SHEET NO.
290	(3031.1, ETC., 3838)RS-5	COOK	298	220
FED. ROAD DIST. NO. ILLINOIS FED. AID PROJECT			CONTRACT NO. 60G52	

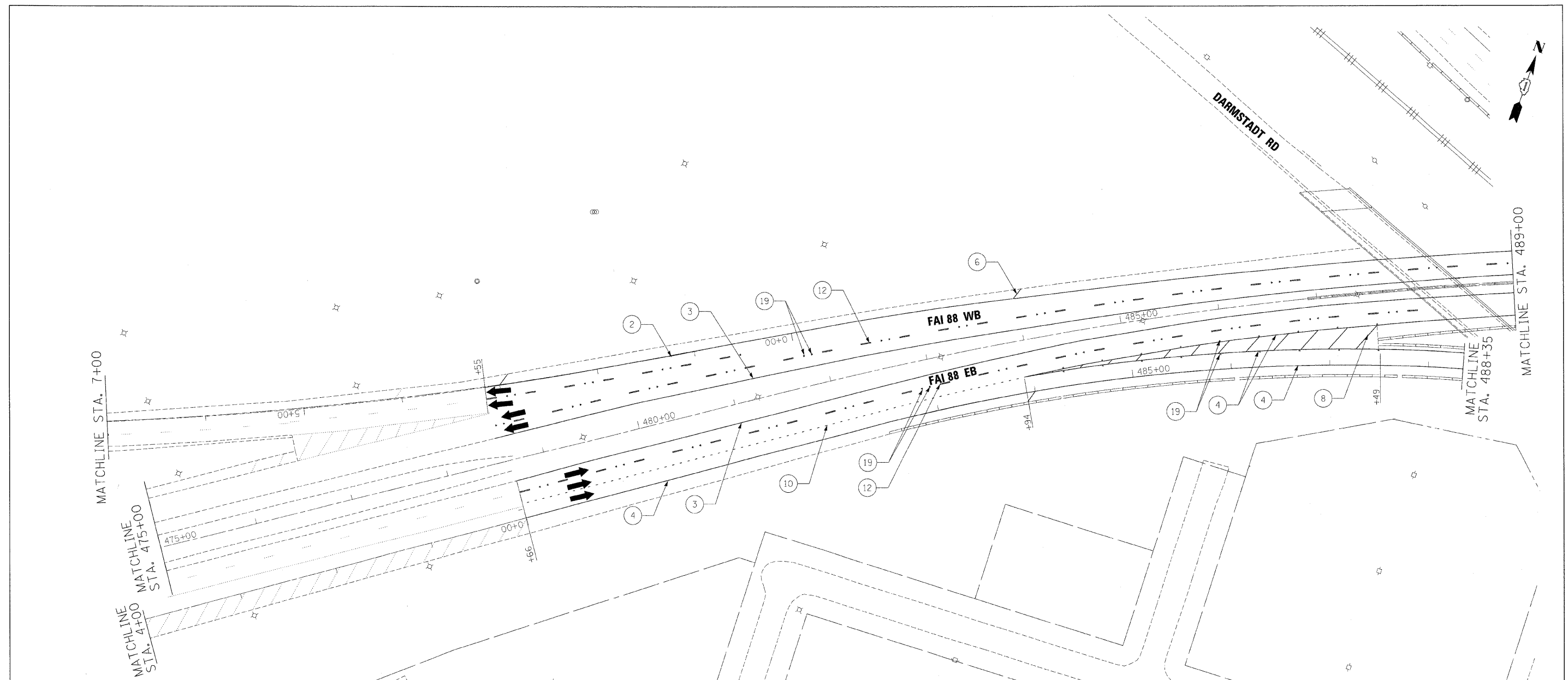

LEGEND

- ① THERMOPLASTIC PAVEMENT MARKING - LETTERS AND SYMBOLS (WHITE)
- ② THERMOPLASTIC PAVEMENT MARKING - LINE 4" (WHITE EDGE LINE)
- ③ THERMOPLASTIC PAVEMENT MARKING - LINE 4" (YELLOW EDGE LINE)
- ④ THERMOPLASTIC PAVEMENT MARKING - LINE 8" (WHITE EDGE LINE)
- ⑤ THERMOPLASTIC PAVEMENT MARKING - LINE 8" (WHITE DIAGONALS SPACED @ 30' CENTERS)
- ⑥ THERMOPLASTIC PAVEMENT MARKING - LINE 12" (WHITE DIAGONALS SPACED @ 500' CENTERS)
- ⑦ THERMOPLASTIC PAVEMENT MARKING - LINE 12" (YELLOW DIAGONALS SPACED @ 500' CENTERS)
- ⑧ THERMOPLASTIC PAVEMENT MARKING - LINE 12" (WHITE GORE DIAGONALS SPACED @ 30' CENTERS)
- ⑨ THERMOPLASTIC PAVEMENT MARKING - LINE 24" (WHITE)
- ⑩ PREFORMED PLASTIC PAVEMENT MARKING, TYPE B, INLAID, LINE 4" (WHITE 2' DASH, 6" SKIP)
- ⑪ PREFORMED PLASTIC PAVEMENT MARKING, TYPE B, INLAID, LINE 8" (WHITE 3' DASH, 9" SKIP)
- ⑫ PREFORMED PLASTIC PAVEMENT MARKING, TYPE B, INLAID, LINE 5" (WHITE 10' DASH, 30' SKIP)
- ⑬ POLYUREA PAVEMENT MARKING TYPE 1, LINE 4" (WHITE EDGE LINE)
- ⑭ POLYUREA PAVEMENT MARKING TYPE 1, LINE 4" (YELLOW EDGE LINE)
- ⑮ POLYUREA PAVEMENT MARKING TYPE 1, LINE 8" (WHITE EDGE LINE)
- ⑯ POLYUREA PAVEMENT MARKING TYPE 1, LINE 5" (WHITE 10' DASH, 30' SKIP)
- ⑰ POLYUREA PAVEMENT MARKING TYPE 1, LINE 12" (WHITE GORE DIAGONALS SPACED @ 30' CENTERS)
- ⑱ RAISED REFLECTIVE PAVEMENT MARKER (1-WAY YELLOW / OPAQUE)
- ⑲ RAISED REFLECTIVE PAVEMENT MARKER (1-WAY CRYSTAL / OPAQUE)
- ⑳ THERMOPLASTIC PAVEMENT MARKING - LINE 12" (WHITE EDGE LINE)
- ㉑ THERMOPLASTIC PAVEMENT MARKING - LINE 6" (WHITE THRU LANE LINE)
- ㉒ POLYUREA PAVEMENT MARKING TYPE 1, LINE 12" (YELLOW DIAGONALS SPACED @ 500' CENTERS)
- ㉓ POLYUREA PAVEMENT MARKING TYPE 1, LINE 12" (WHITE DIAGONALS SPACED @ 500' CENTERS)
- ㉔ POLYUREA PAVEMENT MARKING TYPE 1, LETTERS AND SYMBOLS (WHITE)
- ㉕ POLYUREA PAVEMENT MARKING TYPE 1, LINE 8" (WHITE 3' DASH, 9" SKIP)
- ㉖ POLYUREA PAVEMENT MARKING TYPE 1, LINE 4" (WHITE 2' DASH, 6" SKIP)

NOTE:

1. SEE IDOT DISTRICT 1 STANDARD TC-12 "MULTI-LANE FREEWAY PAVEMENT MARKING DETAILS" FOR PLACEMENT AND TYPE OF RAISED REFLECTIVE PAVEMENT MARKERS.
2. FOR PROPOSED PAVEMENT MARKINGS IN THE PCC SECTIONS USE POLYUREA PAVEMENT MARKINGS ACCORDING TO STANDARD TC-12.
3. REFER TO ROADWAY PLANS FOR LIMITS OF RESURFACING.

FILE NAME =	DESIGNED - AJP	REVISED -
...xprp1n_abc_c2_138.pvmtmkg_05.dgn	DRAWN - TMB	REVISED -
USER NAME = tbi/ank	CHECKED - JMM	REVISED -
PLOT DATE = 12/16/2009	DATE - 10/16/09	REVISED -

benesch

**STATE OF ILLINOIS
DEPARTMENT OF TRANSPORTATION**

**PAVEMENT MARKING PLANS
ROOSEVELT ROAD / IL RTE 38**

SCALE: 1"=50' SHEET NO. 31 OF 31 SHEETS STA. TO STA.

F.A.I. RTE.	SECTION	COUNTY	TOTAL SHEETS	SHEET NO.
290	(3031.1, ETC., 3830)RS-5	COOK	298	221
FED. ROAD DIST. NO.			IL. INOIS FED. AID PROJECT	
CONTRACT NO. 60C52				

STATE OF ILLINOIS
DEPARTMENT OF TRANSPORTATION

* Measured Radial
** Measured along Local Tangent at Sta. 459+00

Existing Structure:
The structure is a four-span continuous steel structure (composite) with a 7.5-inch reinforced concrete deck and no overlay.
The original structure was built in 1953 and is in Section (3738 & 3838) R-1. In 1984, the bridge was widened and redecked, expansion joints were reconstructed, substructure was repaired, and the superstructure was cleaned and painted. In 1997, the expansion joints were reconstructed and approach slabs were repaired. In 2001, the deck was widened and the substructure was repaired.

Stage construction shall be utilized to maintain traffic during construction.

No salvage.

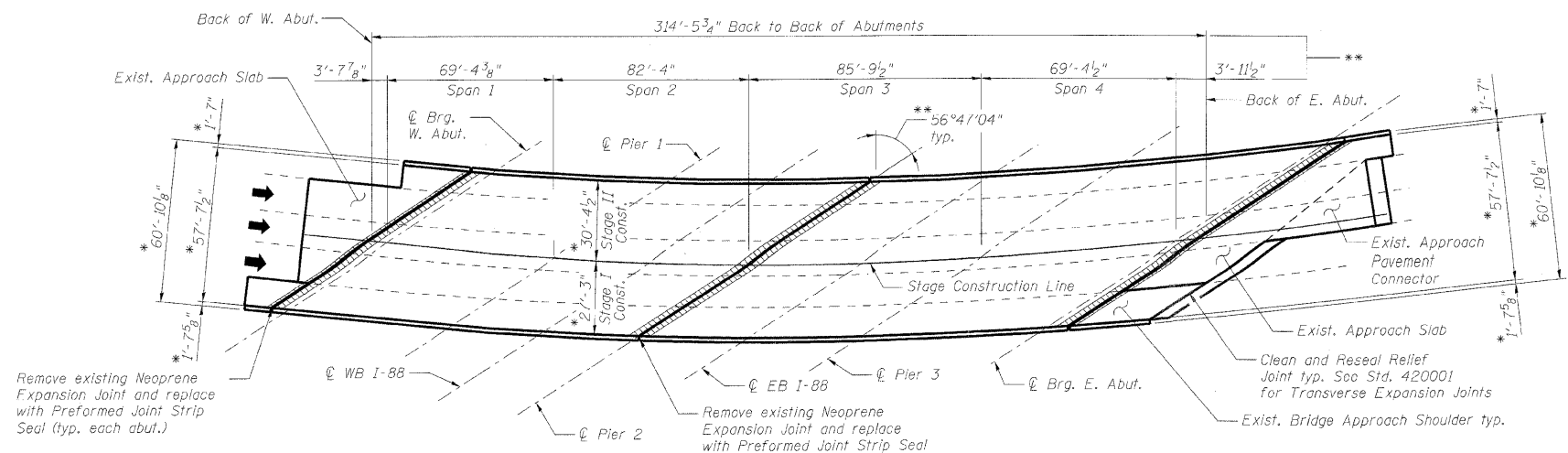

PLAN

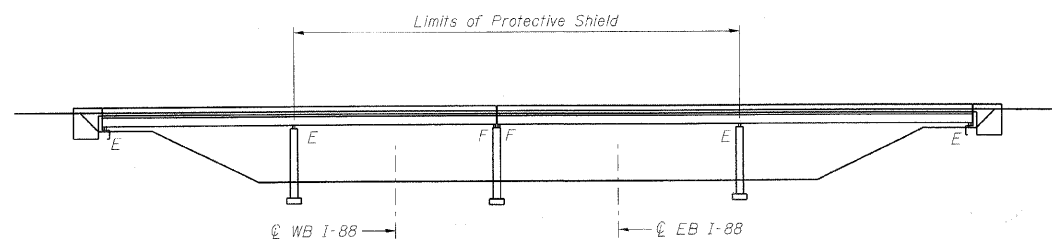

ELEVATION

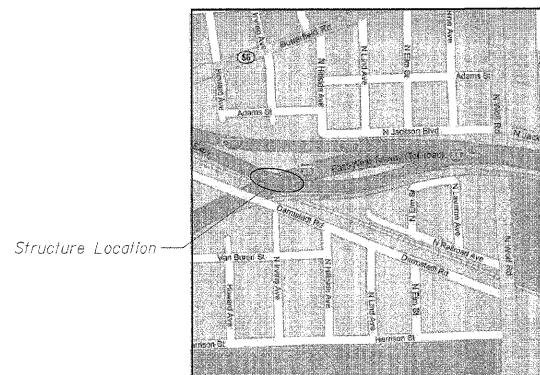

LOCATION SKETCH

DESIGN SPECIFICATIONS

2002 AASHTO Standard Specifications for Highway Bridges, 17th Edition

DESIGN STRESSES

$f'_c = 3,500$ psi
 $f_y = 60,000$ psi

SCOPE OF WORK

1. Repair bridge deck.
2. Repair approach slab.
3. Reconstruct deck joints at each abutment and Pier 2 with preformed joint strip seal.
4. Clean and reseal relief joints at the end of approach pavement connectors.
5. Apply concrete sealer to parapets, abutment seats and backwalls, and Pier 2 seats.



Expiration Date 11-30-10
DATE: 11/16/09

GENERAL PLAN AND ELEVATION
I-290 EB OVER I-88
COOK COUNTY
STATION 459+00
STRUCTURE NO. 016-0085

DESIGNED -	DMS/TJJ
CHECKED -	EFS/AAY
DRAWN -	RMG
CHECKED -	AAY

benesch

alfred benesch & company
Engineers • Surveyors • Planners
205 North Michigan Avenue, Suite 2400
Chicago, Illinois 60601
312-555-0450 Job No. 10050

SHEET NO. 1 9 SHEETS	F.A.I. RTE.	SECTION	COUNTY	TOTAL SHEETS	SHEET NO.
	290	(3031.1, ETC., 3838)RS-5	COOK	298	222
FED. ROAD DIST. NO.			ILLINOIS	FED. AID PROJECT	
CONTRACT NO. 60G52					

STATE OF ILLINOIS
DEPARTMENT OF TRANSPORTATION

GENERAL NOTES

1. Reinforcement bars shall conform to the requirements of ASTM A 706 Gr 60. See Special Provisions.
2. Reinforcement bars designated (E) shall be epoxy coated.
3. Prior to pouring the new concrete deck, all heavy or loose rust, loose mill scale, and other loose or potentially detrimental foreign material shall be removed from the surfaces in contact with concrete. Tightly adhered paint may remain unless otherwise noted. Removal shall be accomplished by methods that will not damage the steel and the cost will be included in the pay item covering removal of the existing concrete.
As directed by the Engineer, existing construction accessories welded to the top flange of beams and girders shall be removed. The weld areas shall be ground flush and inspected for cracks using magnetic particle testing (MT) or dye penetrant testing (PT) by qualified personnel approved by the Engineer. Any cracks that cannot be removed by grinding 1/4 inch deep shall be identified and reported to the Bureau of Bridges and Structures for further disposition. The cost of removing welded accessories, grinding and inspecting weld areas and grinding cracks will be paid for according to Article 109.04 of the Standard Specifications.
4. Plan dimensions and details relative to existing plans are subject to nominal construction variations. The Contractor shall field verify existing dimensions and details affecting new construction and make necessary approved adjustments prior to construction or ordering of materials. Such variations shall not be cause for additional compensation for a change in scope of the work, however, the Contractor will be paid for the quantity actually furnished at the unit price bid for the work.
5. Concrete Sealer shall be applied to the parapets, abutment and Pier 2 seats, and abutment backwalls. All surfaces to be sealed shall be cleaned thoroughly prior to sealer application. Cost included with Concrete Sealer.
6. The existing structural steel coating contains lead. The Contractor shall take appropriate precautions to deal with the presence of lead on this project.
7. Stage construction shall be utilized to maintain traffic during construction.
8. The Contractor shall exercise care during removal of existing joints to ensure that the slab, beams and diaphragms' integrity will not be detrimentally impacted. The Contractor shall repair any damage(s) to the slab, beams and diaphragms caused by his operation as directed by the Engineer at no additional cost to the Department.
9. Joint openings shall be adjusted according to Article 520.04 of the Standard Specifications when the deck is poured at an ambient temperature other than 50°F.

INDEX OF SHEETS

1. General Plan and Elevation
2. General Notes, Bill of Material and Index of Sheets
3. Stage Construction Details
4. Bridge Deck And Approach Slab Repairs
5. Expansion Joint Repairs 1 of 2
6. Expansion Joint Repairs 2 of 2
7. Expansion Joint Details
8. Preformed Joint Strip Seal
9. Bar Splicer Assembly Details

TOTAL BILL OF MATERIAL

ITEM	UNIT	SUPER	SUB	TOTAL
Concrete Removal	Cu. Yd.	46.7		46.7
Protective Shield	Sq. Yd.	130		130
Concrete Superstructure	Cu. Yd.	46.7		46.7
Reinforcement Bars, Epoxy Coated	Pound	6,180		6,180
Bar Splicers	Each	38		38
Preformed Joint Strip Seal	Foot	328.0		328.0
Concrete Sealer	Sq. Ft.	26,310	1,592	27,902
Approach Slab Repair (Partial Depth)	Sq. Yd.	10.0		10.0
Deck Slab Repair (Partial)	Sq. Yd.	5.6		5.6
Clean & Reseal Relief Joint	Foot	104.0		104.0

**GENERAL NOTES, BILL OF MATERIAL
AND INDEX OF SHEETS
STRUCTURE NO. 016-0085**

DESIGNED -	DMS/TJJ
CHECKED -	EFS/AAV
DRAWN -	RMG
CHECKED -	AAV

benesch

alfred benesch & company
Engineers • Surveyors • Planners
205 North Michigan Avenue, Suite 2400
Chicago, Illinois 60601
312-565-0450 Job No. 10050

SHEET NO. 2	F.A.I. RTE.	SECTION	COUNTY	TOTAL SHEETS	SHEET NO.
	290	(3031.1, ETC., 3838)RS-5	COOK	298	223
9 SHEETS	CONTRACT NO. 60G52				
FED. ROAD DIST. NO.		ILLINOIS	FED. AID PROJECT		

STATE OF ILLINOIS
DEPARTMENT OF TRANSPORTATION

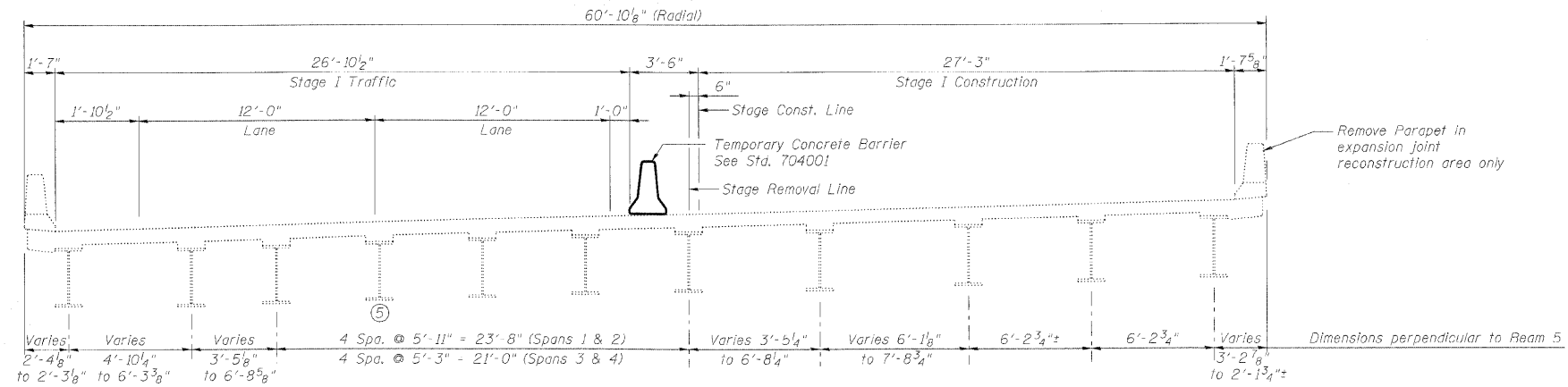

STAGE I CROSS SECTION
(Looking East)

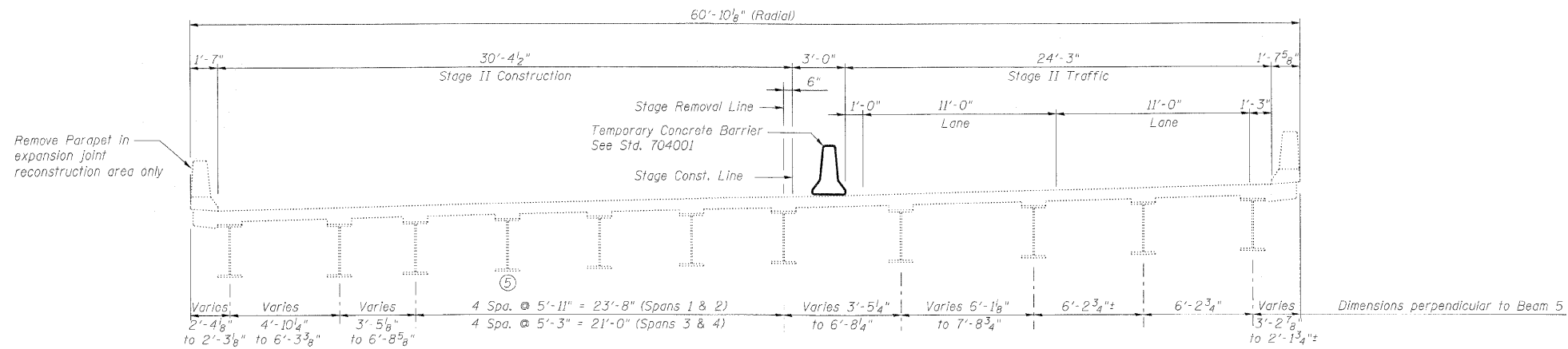

STAGE II CROSS SECTION
(Looking East)

Note:

For quantity of Temporary Concrete Barrier, see roadway plans.

STAGE CONSTRUCTION DETAILS
STRUCTURE NO. 016-0085

DESIGNED	MFB
CHECKED	MAC
DRAWN	VH
CHECKED	AAY

benesch

alfred benesch & company
Engineers • Surveyors • Planners
205 North Michigan Avenue, Suite 2400
Chicago, Illinois 60601
312-565-0450 Job No. 10050

SHEET NO. 3 9 SHEETS	F.A.I. RTE.	SECTION	COUNTY	TOTAL SHEETS	SHEET NO.
	290	(3031.1, ETC., 3838)RS-5	COOK	298	224
FED. ROAD DIST. NO.			ILLINOIS	FED. AID PROJECT	
CONTRACT NO. 60G52					

STATE OF ILLINOIS
DEPARTMENT OF TRANSPORTATION

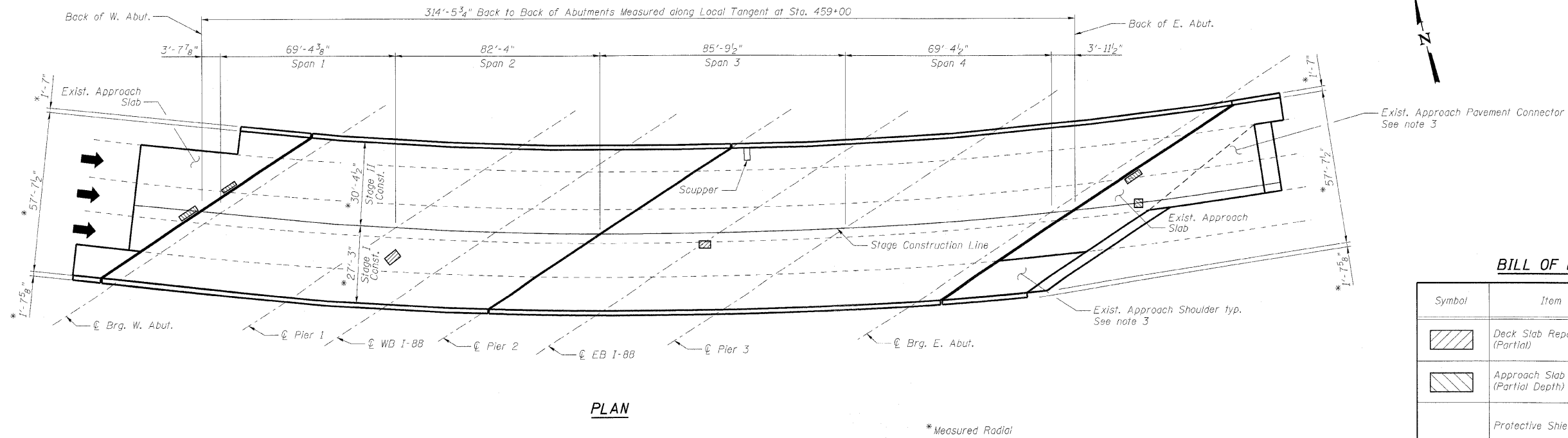

PLAN

* Measured Radial

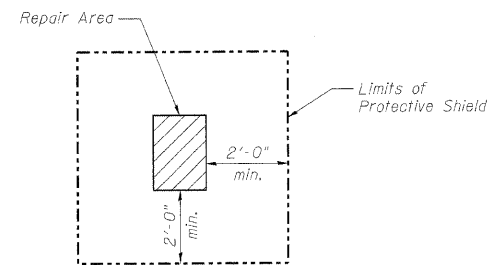

PROTECTIVE SHIELD DETAIL

BILL OF MATERIAL

Symbol	Item	Unit	Quantity
	Deck Slab Repair (Partial)	Sq. Yd.	5.6
	Approach Slab Repair (Partial Depth)	Sq. Yd.	10.0
	Protective Shield	Sq. Yd.	130

Notes:

- Deck and approach slab repair areas are estimated based on visual inspection completed in June 2009. Actual repair areas and locations shall be determined by the Engineer and shown on As-Built plans.
- Protective Shield, required for deck slab and/or parapet repairs, shall be installed according to Article 501.03 of the Standard Specifications. For limits of Protective Shield, see Protective Shield Detail on this sheet and Elevation on General Plan and Elevation sheet.
- The Engineer shall determine the type and quantity of Class A patching and the quantity of Mixture for Cracks, Joints and Flangeways. Estimated quantities are included in the overall Summary of Quantities in Roadway Plans.

BRIDGE DECK AND APPROACH
SLAB REPAIRS
STRUCTURE NO. 016-0085

DESIGNED	DMS/TJJ
CHECKED	EFS/AAY
DRAWN	RMG
CHECKED	AAY

benesch

alfred benesch & company
Engineers • Surveyors • Planners
205 North Michigan Avenue, Suite 2400
Chicago, Illinois 60601
312-565-0450 Job No. 10050

SHEET NO. 4 9 SHEETS	F.A.I. RTE.	SECTION	COUNTY	TOTAL SHEETS	SHEET NO.
	290	(3031.1, ETC., 3838)RS-5	COOK	298	225
FED. ROAD DIST. NO.			ILLINOIS	FED. AID PROJECT	
CONTRACT NO. 60G52					

STATE OF ILLINOIS
DEPARTMENT OF TRANSPORTATION

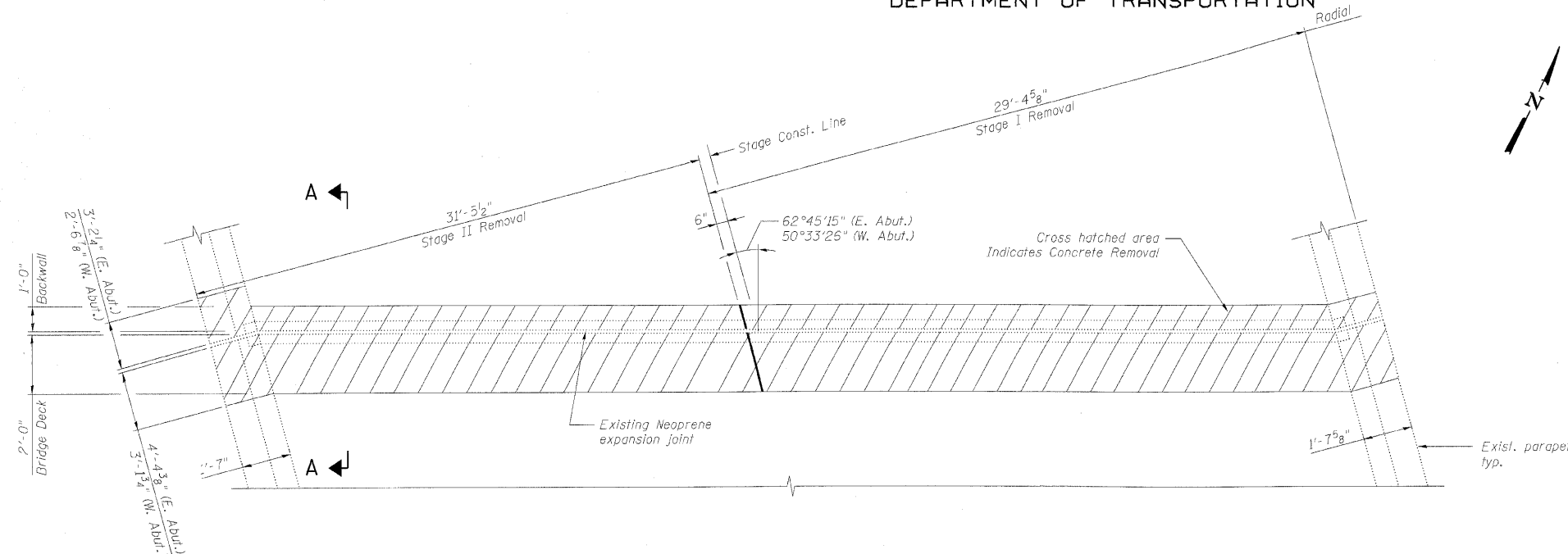

EXISTING PARTIAL PLAN AT WEST ABUTMENT
(Opposite Hand for East Abutment)

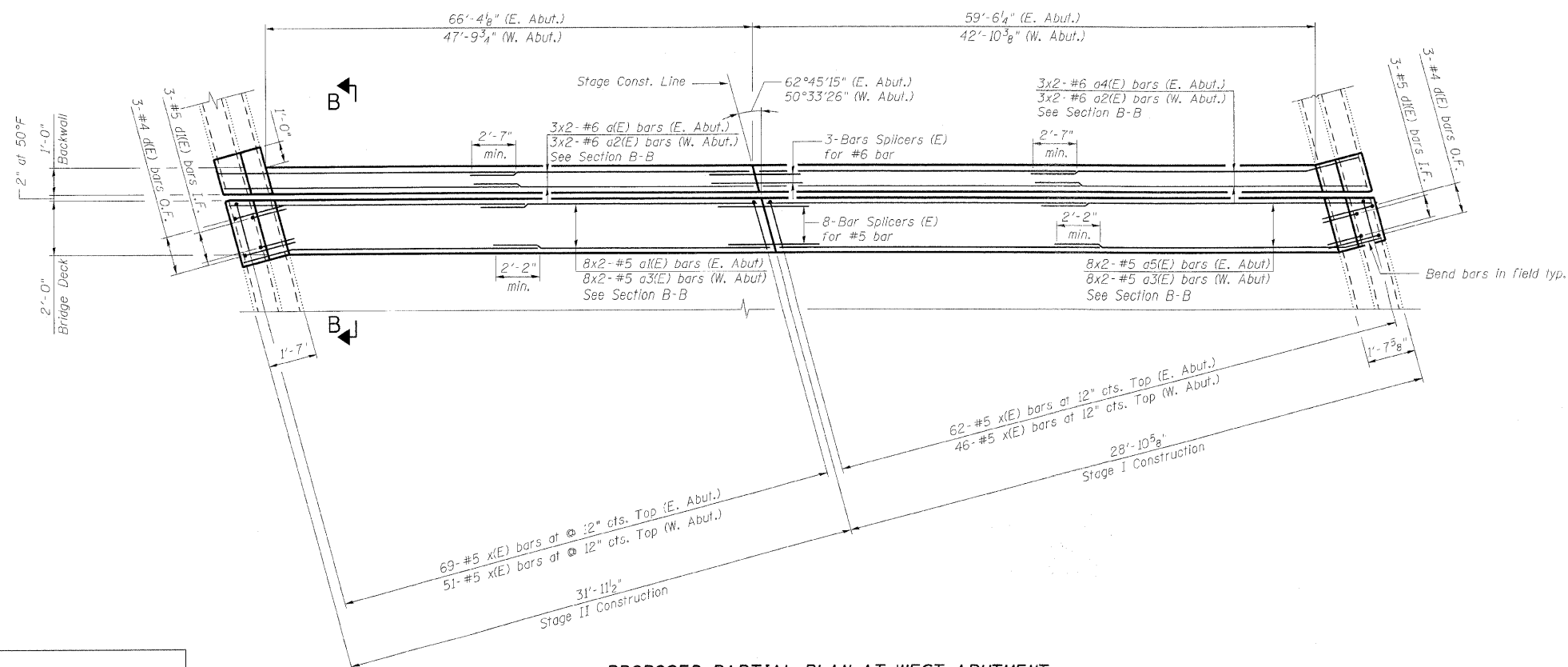

PROPOSED PARTIAL PLAN AT WEST ABUTMENT
(Opposite Hand for East Abutment)

BILL OF MATERIAL

Bar	No.	Size	Length	Shape
a1(E)	6	#6	35'-9"	—
a1(E)	16	#5	35'-9"	—
a2(E)	12	#6	26'-3"	—
a3(E)	32	#5	26'-3"	—
a4(E)	6	#6	32'-5"	—
a5(E)	16	#5	32'-5"	—
d(E)	12	#4	5'-3"	┌
d1(E)	12	#5	3'-11"	└
x(E)	228	#5	2'-3"	┌
Item	Unit	Total		
Concrete Removal	Cu. Yd.	30.7		
Concrete Superstructure	Cu. Yd.	30.7		
Reinforcement Bars, Epoxy Coated	Pound	3,730		

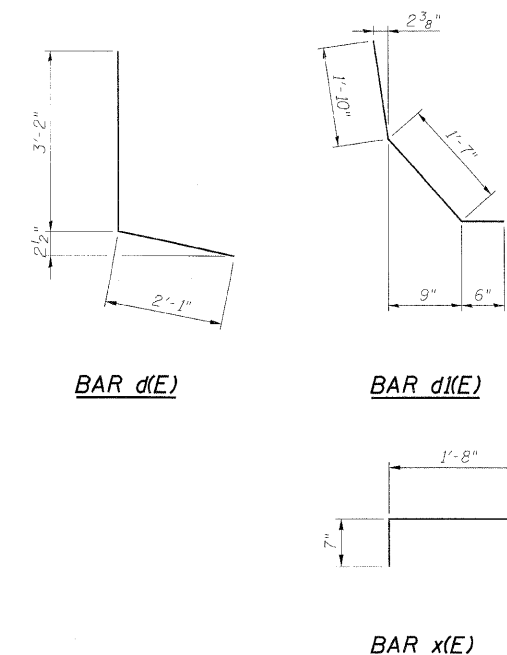

Notes:

1. Bars indicated thus 8x2-#5 etc. indicates 8 lines of bars with 2 lengths per line.
2. I.F. denotes Inside Face.
O.F. denotes Outside Face.
3. Work this sheet with Expansion Joint Details sheet and Bar Splicer Assembly Details sheet.
4. x(E) bar spacing measured along skew.

EXPANSION JOINT REPAIRS 1 of 2
STRUCTURE NO. 016-0085

DESIGNED -	TJJ
CHECKED -	AAY
DRAWN -	VH
CHECKED -	AAY

benesch

alfred benesch & company
Engineers • Surveyors • Planners
205 North Michigan Avenue, Suite 2400
Chicago, Illinois 60601
312-665-0450 Job No. 10050

SHEET NO. 5 9 SHEETS	F.A.I. RTE.	SECTION	COUNTY	TOTAL SHEETS	SHEET NO.
	290	(3031.1, ETC., 3838)RS-5	COOK	298	226
FED. ROAD DIST. NO.			ILLINOIS	FED. AID PROJECT	
			CONTRACT NO. 60G52		

STATE OF ILLINOIS
DEPARTMENT OF TRANSPORTATION

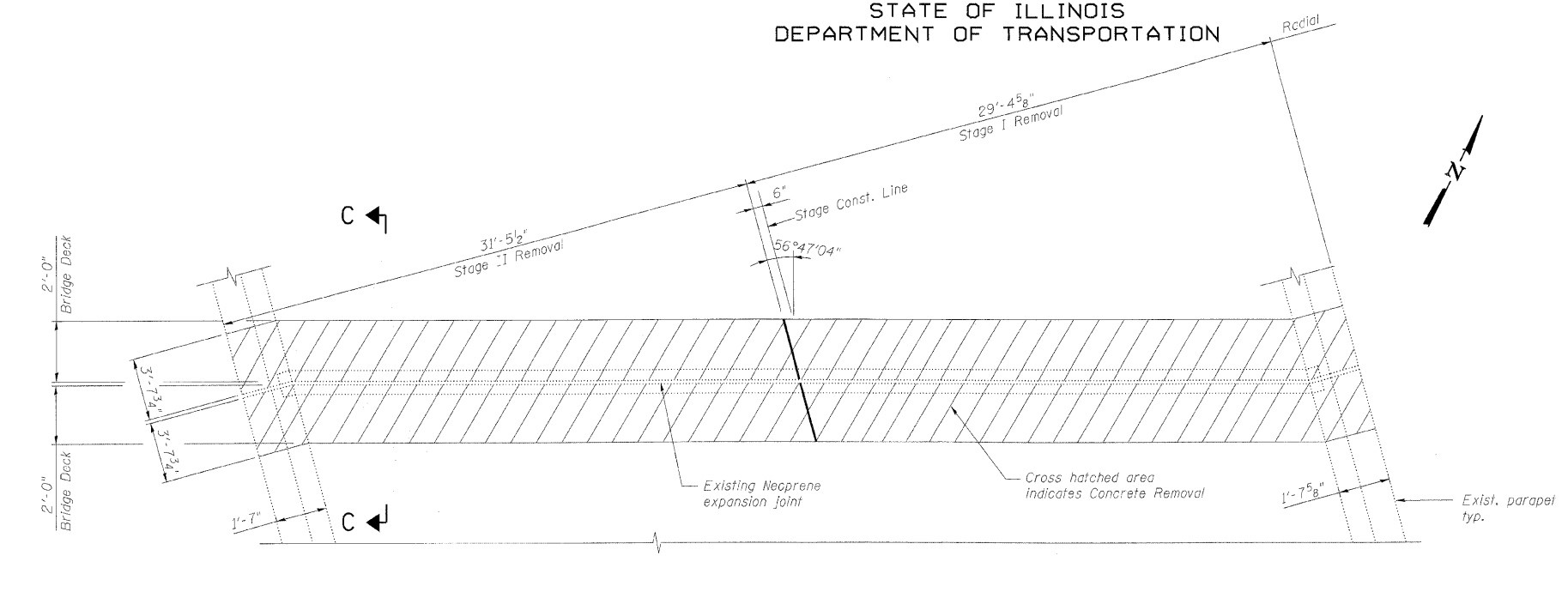

EXISTING PARTIAL PLAN AT PIER 2

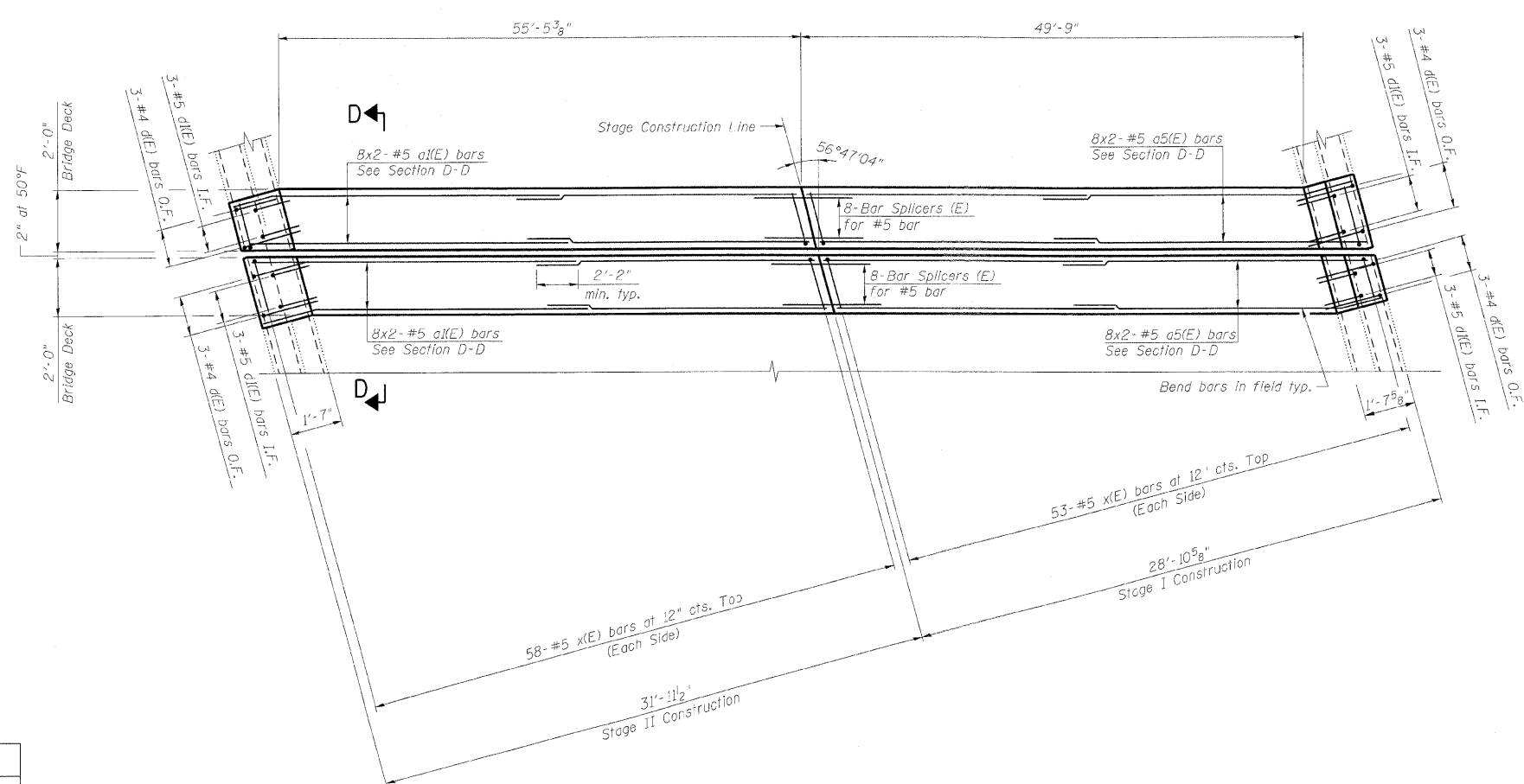

PROPOSED PARTIAL PLAN AT PIER 2

BILL OF MATERIAL

Bar	No.	Size	Length	Shape
a1(E)	32	#5	29'-11"	—
a5(E)	32	#5	26'-7"	—
d(E)	12	#4	5'-3"	┌
d1(E)	12	#5	3'-11"	┌
x(E)	222	#5	2'-3"	┌
Item		Unit	Total	
Concrete Removal		Cu. Yd.	15.0	
Concrete Superstructure		Cu. Yd.	15.0	
Reinforcement Bars, Epoxy Coated		Pound	2,450	

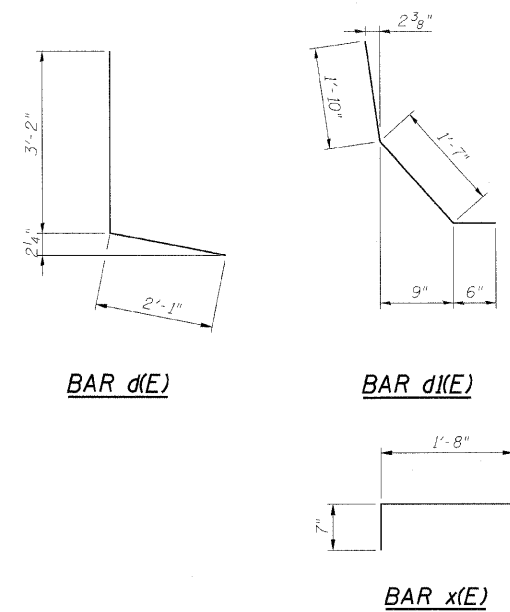

- Notes:**
1. Bars indicated thus 8x2-#5 etc. Indicates 8 lines of bars with 2 lengths per line.
 2. I.F. denotes Inside Face.
O.F. denotes Outside Face.
 3. Work this sheet with Expansion Joint Details sheet and Bar Splicer Assembly Details sheet.
 4. x(E) bar spacing measured along skew.

DESIGNED	TJJ
CHECKED	AAY
DRAWN	VH
CHECKED	AAY

benesch
alfred benesch & company
Engineers • Surveyors • Planners
205 North Michigan Avenue, Suite 2400
Chicago, Illinois 60601
312-565-0450 Job No. 10050

SHEET NO. 6 9 SHEETS	F.A.I. RTE.	SECTION	COUNTY	TOTAL SHEETS	SHEET NO.
	290	(3031.1, ETC., 3838)RS-5	COOK	298	227
FED. ROAD DIST. NO.			ILLINOIS	FED. AID PROJECT	
CONTRACT NO. 60G52					

EXPANSION JOINT REPAIRS 2 of 2
STRUCTURE NO. 016-0085

x:\100000s\10050\Engineering\Documents-Contract.2\SN_016_0085_188_TOLLWAY_0085-60G52-006-ExpJ-repair-2.dgn
 17:48:28
 11/12/2009

STATE OF ILLINOIS
DEPARTMENT OF TRANSPORTATION

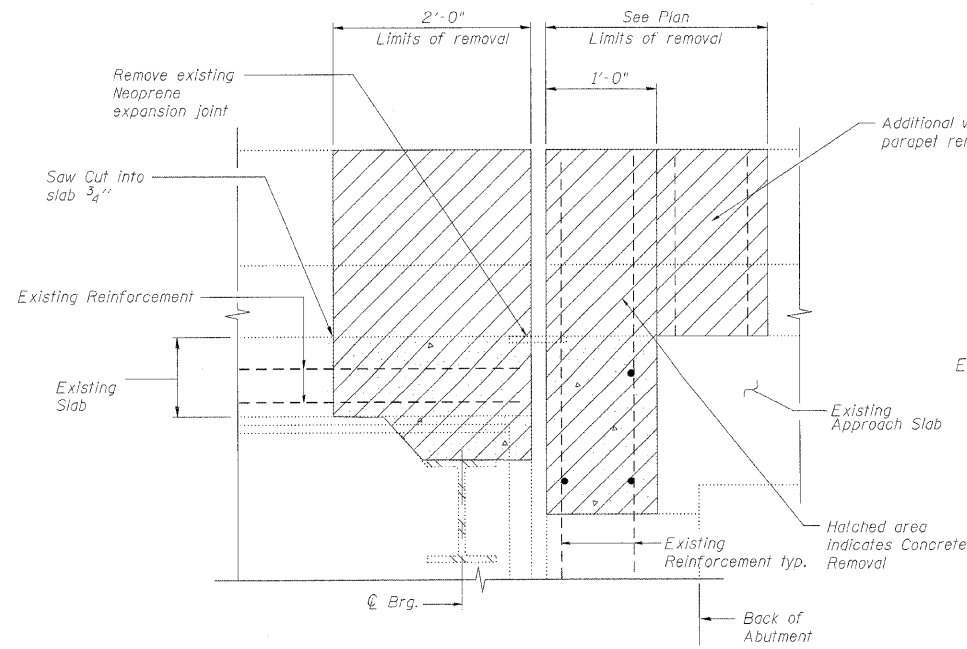

SECTION A-A

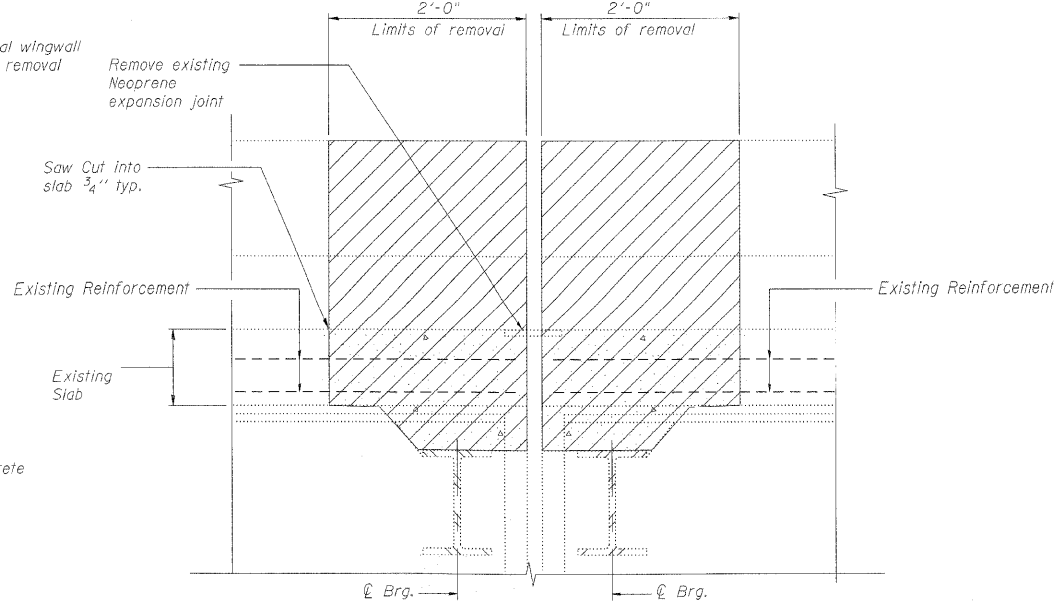

SECTION C-C

Notes:

- Existing reinforcement bars extending into the concrete removal area shall be blast-cleaned, straightened and incorporated into the new construction. Any reinforcement bars that are damaged during concrete removal shall be repaired or replaced with an approved bar splicer or anchorage system. Cost included with Concrete Removal.
- Existing reinforcement bars in the concrete removal area parallel to the expansion joints shall be removed.
- Removal and disposal of the existing expansion joints will not be paid for separately, but shall be included with the cost of Concrete Removal.
- If existing name plate falls within the limits of Concrete Removal, it shall be removed and reinstalled in its original location in accordance with IDOT Std. 515001. Cost included with Concrete Superstructure.
- If existing guardrail and/or end shoe fall within the limits of Concrete Removal, they shall be removed and reinstalled in their original location in accordance with District 1 Std. BM-21. Cost included with Concrete Superstructure.
- Work this sheet with Expansion Joint Repairs sheet.

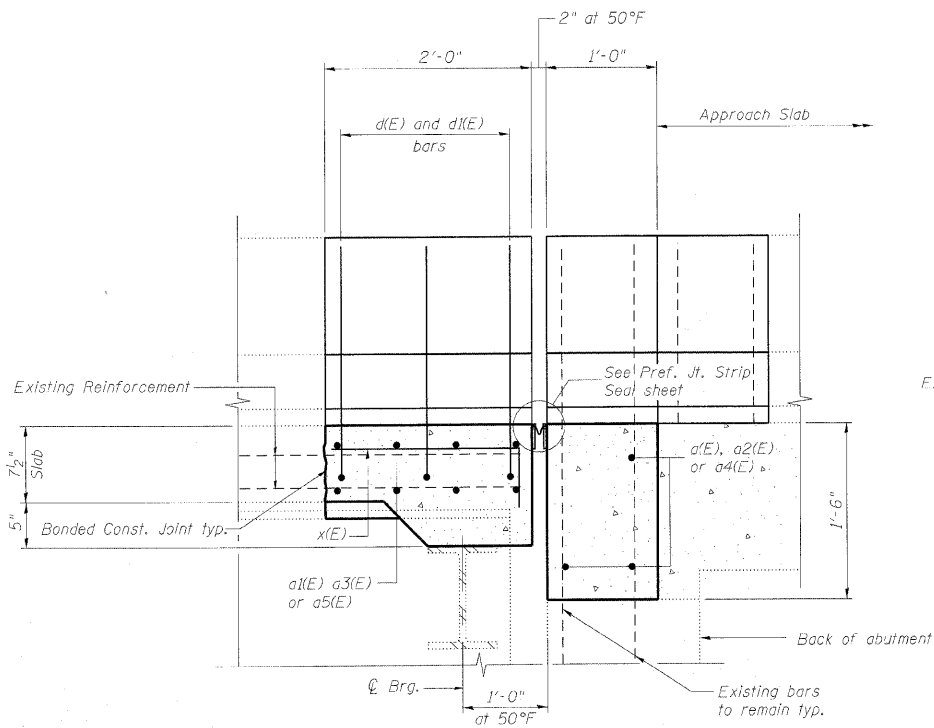

SECTION B-B

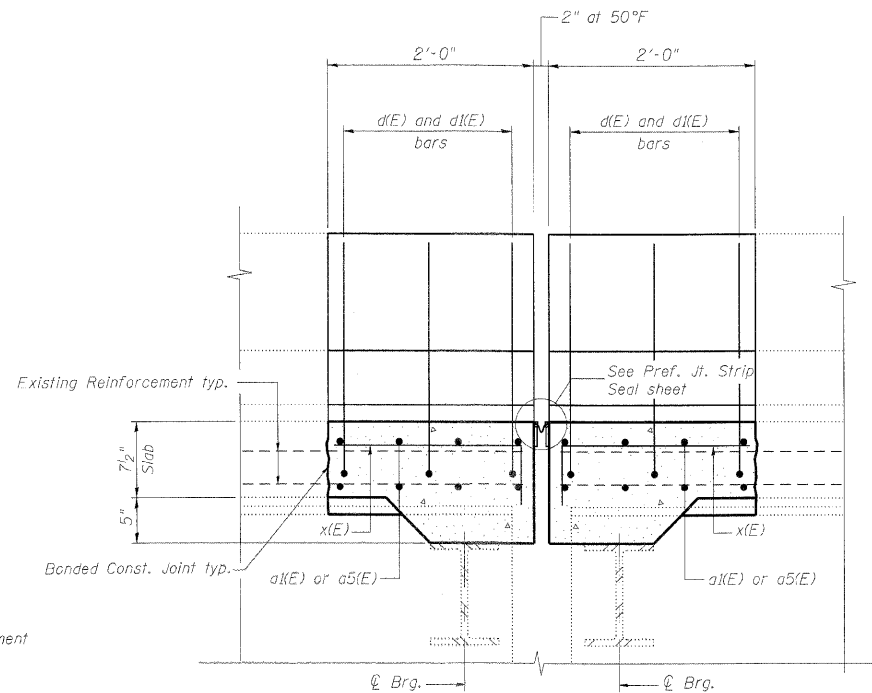

SECTION D-D

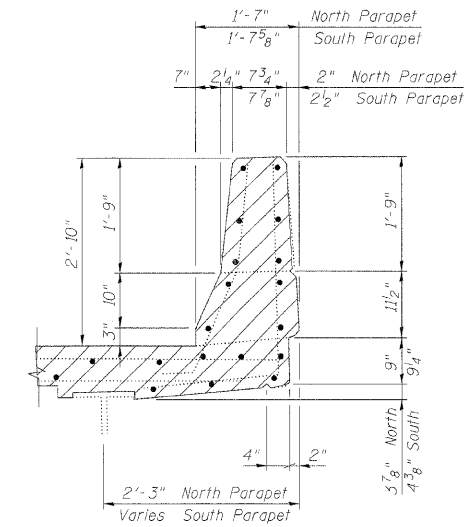

EXISTING PARAPET SECTION

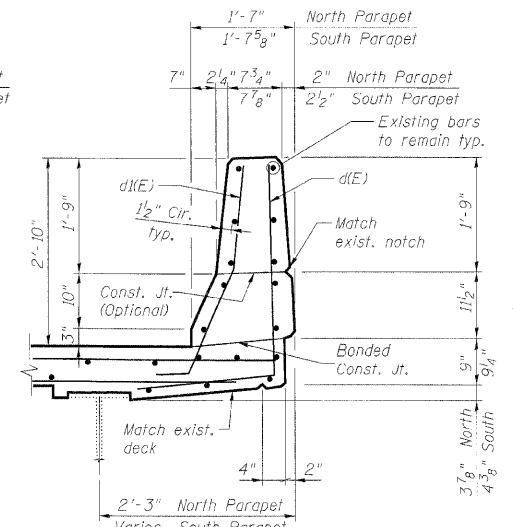

PROPOSED PARAPET SECTION

DESIGNED	TJJ
CHECKED	AAY
DRAWN	VH
CHECKED	AAY

EXPANSION JOINT DETAILS
STRUCTURE NO. 016-0085

benesch

alfred benesch & company
Engineers • Surveyors • Planners
205 North Michigan Avenue, Suite 2400
Chicago, Illinois 60601
312-565-0450 Job No. 10050

SHEET NO. 7 9 SHEETS	F.A.I. RTE.	SECTION	COUNTY	TOTAL SHEETS	SHEET NO.
	290	(3031.1, ETC., 3838)RS-5	COOK	298	228
FED. ROAD DIST. NO.			ILLINOIS FED. AID PROJECT		
CONTRACT NO. 60G52					

STATE OF ILLINOIS
DEPARTMENT OF TRANSPORTATION

* Granular or solid flux filled headed studs conforming to Article 1006.32 of the Std. Specs., automatically end welded.

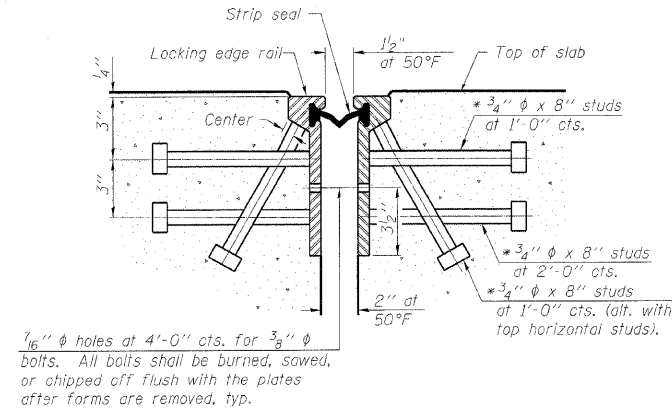

SECTION THRU
ROLLED RAIL JOINT

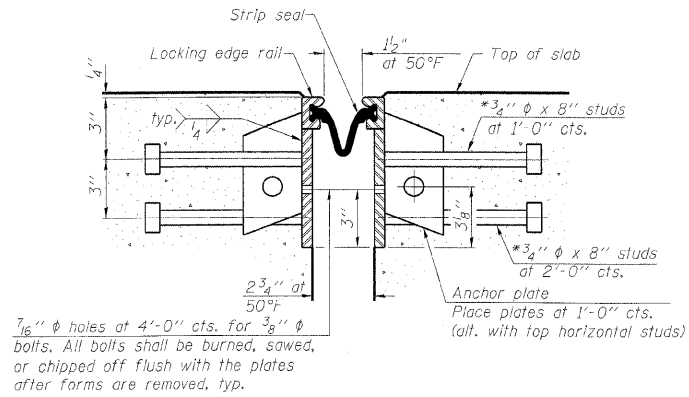

SECTION THRU
WELDED RAIL JOINT

Notes:

The strip seal shall be made continuous and shall have a minimum thickness of 1/4". The configuration of the strip seal shall match the configuration of the Locking Edge Rails. Open or "webbed" strip seal gland configurations are not permitted. The gland shall be sized for a maximum rated movement of 4 inches.

The height and thickness of the Locking Edge Rails shown are minimum dimensions. The actual configuration of the Locking Edge Rails and matching strip seal may vary from manufacturer to manufacturer. Flanged edge rails will not be allowed. Locking Edge Rails may be spliced at slope discontinuities and stage construction joints.

The manufacturer's recommended installation methods shall be followed. The joint opening and deck dimensions detailed on the superstructure are based on a rolled rail expansion joint. If the Contractor elects to use the welded rail expansion joint, the opening and deck dimensions shall be modified according to the dimensions detailed on this sheet. Required modifications shall be made at no additional cost to the State.

All steel components shall be galvanized after fabrication according to Article 520.03 of the Standard Specifications.

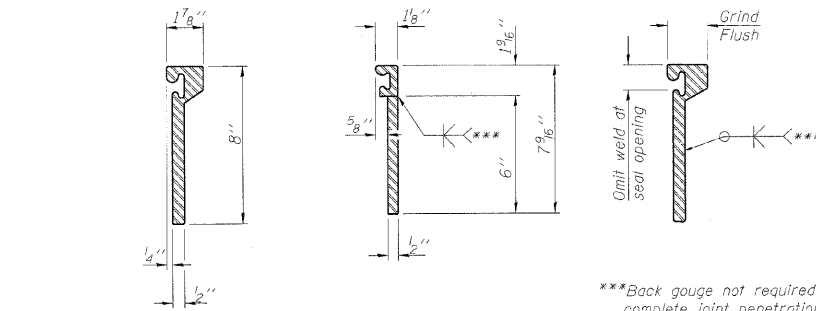

ROLLED
EXTRUDED RAIL WELDED RAIL

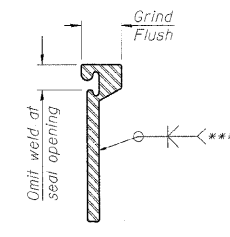

***Back gauge not required if complete joint penetration is verified by mock-up.

LOCKING EDGE
RAIL SPLICE

The inside of the locking edge rail groove shall be free of weld residue.

LOCKING EDGE RAILS

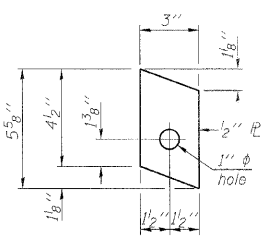

ANCHOR PLATE
(for welded rail)

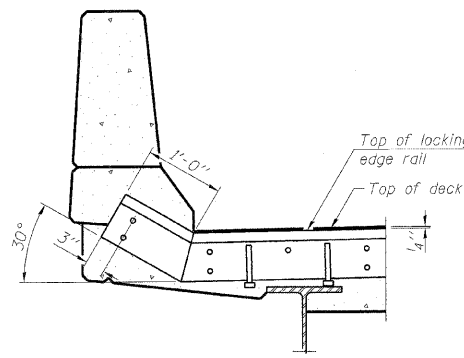

AT PARAPET

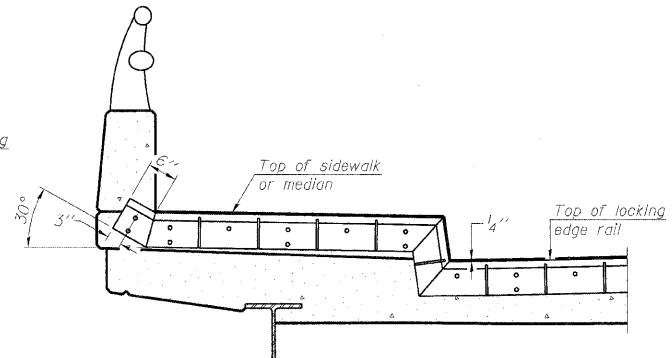

AT SIDEWALK OR MEDIAN

Shorter plates with a single row of studs at 12" cts. may be necessary on medians which are shallower than 9". See manufacturer's recommendation.

TYPICAL END TREATMENTS

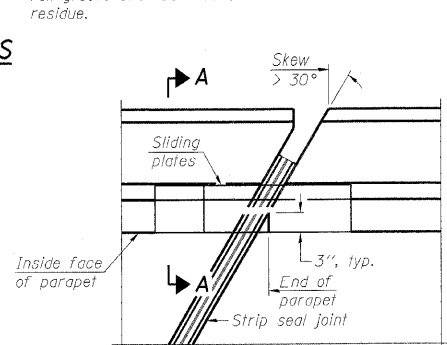

PLAN

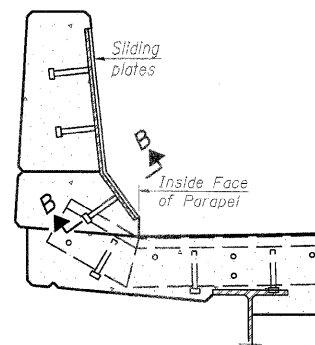

SECTION A-A

POINT BLOCK DETAILS
(for skews > 30°)

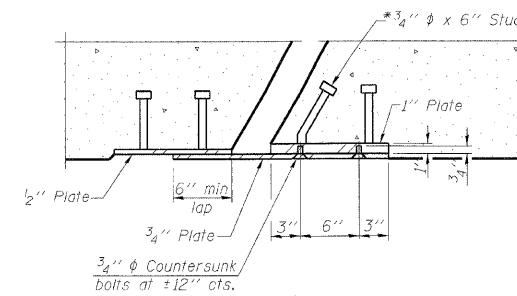

SECTION B-B

BILL OF MATERIAL

Item	Unit	Total
Preformed Joint Strip Seal	Foot	328.0

PREFORMED JOINT STRIP SEAL
STRUCTURE NO. 016-0085

DESIGNED	-	TJJ
CHECKED	-	AAY
DRAWN	-	RMG
CHECKED	-	AAY

EJ-SSJ

10-1-08

benesch

alfred benesch & company
Engineers • Surveyors • Planners
205 North Michigan Avenue, Suite 2400
Chicago, Illinois 60601
312-565-0450 Job No. 10050

SHEET NO. 8 9 SHEETS	F.A.I. RTE.	SECTION	COUNTY	TOTAL SHEETS	SHEET NO.
	290	(3031.1, ETC., 3838)RS-5	COOK	298	229
FED. ROAD DIST. NO.			ILLINOIS	CONTRACT NO. 60G52	
			FED. AID PROJECT		

STATE OF ILLINOIS
DEPARTMENT OF TRANSPORTATION

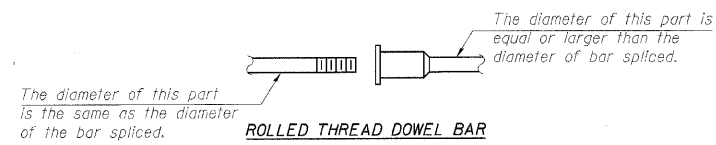

ROLLED THREAD DOWEL BAR



** ONE PIECE

Wire Connector

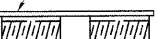

WELDED SECTIONS

BAR SPLICER ASSEMBLY ALTERNATIVES

**Heavy Hex Nuts conforming to ASTM A 563, Grade C, D or DH may be used.

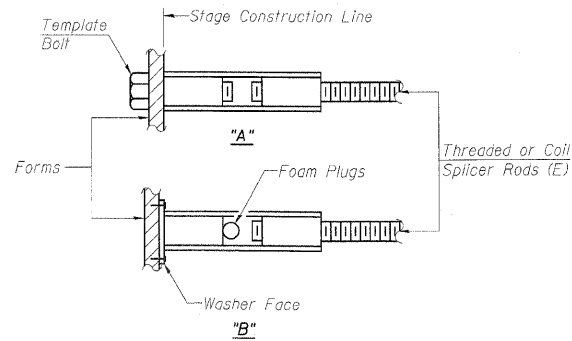

INSTALLATION AND SETTING METHODS

"A": Set bar splicer assembly by means of a template bolt.
"B": Set bar splicer assembly by nailing to wood forms or cementing to steel forms.
(E) : Indicates epoxy coating.

NOTES
Bar splicer assemblies shall be of an approved type and shall develop in tension at least 125 percent of the yield strength of the lapped reinforcement bars.
Splicer rods shall be of minimum 60 ksi yield strength, threaded or coiled full length.
All reinforcement bars shall be lapped and tied to the splicer rods or dowel bars.
Bar splicer assemblies shall be epoxy coated according to the requirements for reinforcement bars.
Other systems of similar design may be submitted to the Engineer for approval. Approval shall be based on certified test results from an approved testing laboratory that the proposed bar splicer assembly satisfies the following requirements:

- ① Minimum Capacity = $1.25 \times f_y \times A_t$
(Tension in kips)
 - ② Minimum *Pull-out Strength = $0.66 \times f_y \times A_t$
(Tension in kips)
- Where f_y = Yield strength of lapped reinforcement bars in ksi.
 A_t = Tensile stress area of lapped reinforcement bars.
* = 28 day concrete

BAR SPLICER ASSEMBLIES			
Bar Size to be Spliced	Splicer Rod or Dowel Bar Length	Strength Requirements	
		Min. Capacity kips - tension	Min. Pull-Out Strength kips - tension
#4	1'-8"	14.7	7.9
#5	2'-2"	23.0	12.3
#6	2'-7"	33.1	17.4
#7	3'-5"	45.1	23.8
#8	4'-6"	58.9	31.3
#9	5'-9"	75.0	39.6
#10	7'-3"	95.0	50.3
#11	9'-0"	117.4	61.8

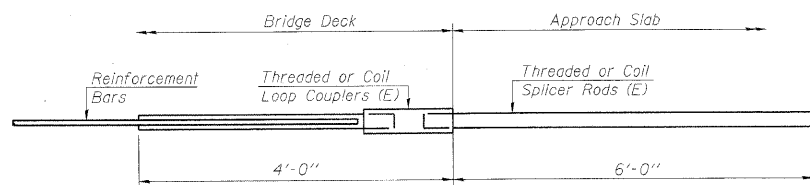

FOR INTEGRAL OR SEMI-INTEGRAL ABUTMENTS

Bar Splicer for #5 bar	
Min. Capacity =	23.0 kips - tension
Min. Pull-out Strength =	12.3 kips - tension
No. Required =	

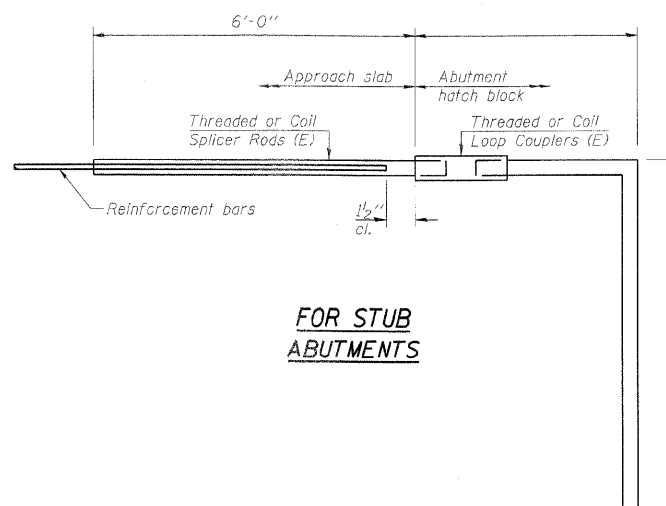

FOR STUB ABUTMENTS

Bar Splicer for #5 bar	
Min. Capacity =	23.0 kips - tension
Min. Pull-out Strength =	12.3 kips - tension
No. Required =	

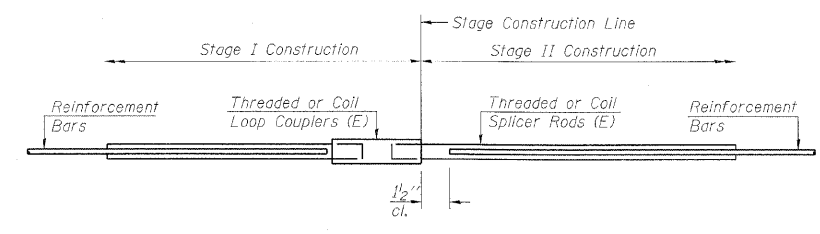

STANDARD

Bar Size	No. Assemblies Required	Location
#5	32	Deck
#6	6	Deck

**BAR SPLICER ASSEMBLY DETAILS
STRUCTURE NO. 016-0085**

DESIGNED -	TJJ
CHECKED -	AAY
DRAWN -	RMG
CHECKED -	AAY

BSD-1

10-1-08

benesch

alfred benesch & company
Engineers • Surveyors • Planners
205 North Michigan Avenue, Suite 2400
Chicago, Illinois 60601
312-565-0450 Job No. 10050

SHEET NO. 9 9 SHEETS	F.A.I. RTE.	SECTION	COUNTY	TOTAL SHEETS	SHEET NO.
	290	(3031.1, ETC., 3838)RS-5	COOK	298	230
FED. ROAD DIST. NO.			ILLINOIS	FED. AID PROJECT	
CONTRACT NO. 60G52					

STATE OF ILLINOIS
DEPARTMENT OF TRANSPORTATION

Existing Structure:
Existing bridge No. 016-0086 at Sta. 62+21.85 was built in 1952
as F.A. Route 131 - project U.I. 251 (21), section 052-3738.1.
The Structure is a three-span continuous W beam bridge with a 7" concrete deck.
It was widened with a new 7 1/2" concrete deck.

Stage construction shall be utilized to maintain traffic during construction.

No salvage

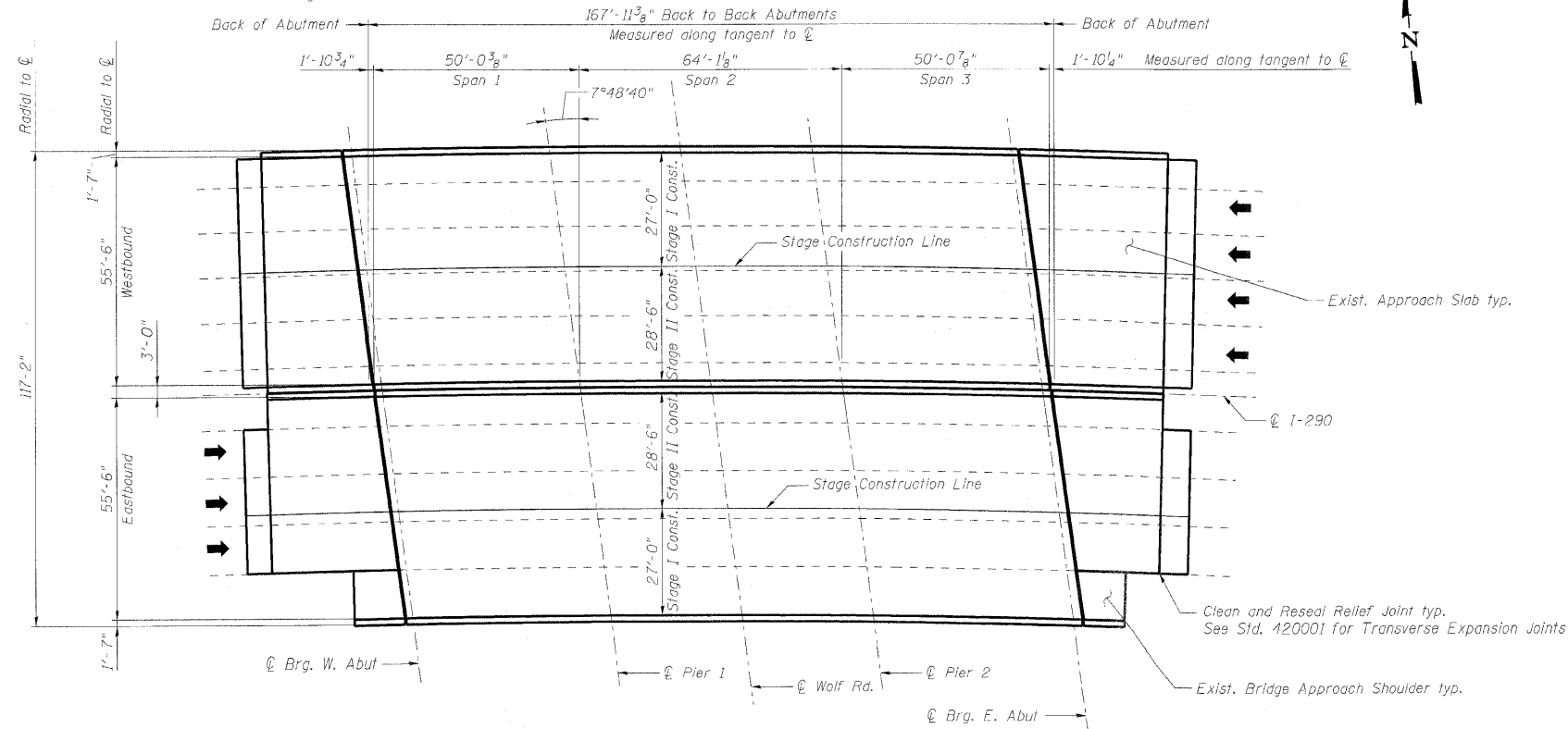

PLAN

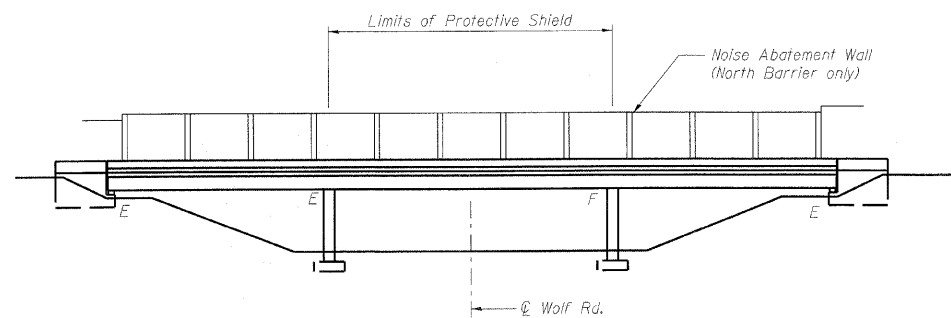

ELEVATION

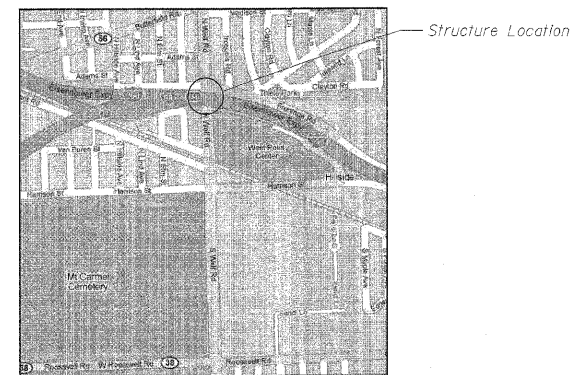

LOCATION SKETCH

DESIGN SPECIFICATIONS

2002 AASHTO Standard Specifications
for Highway Bridges, 17th Edition

DESIGN STRESSES

f'c = 3,500 psi
fy = 60,000 psi

SCOPE OF WORK

1. Repair bridge deck.
2. Repair approach slab.
3. Repair parapet with formed concrete repair.
4. Clean and reseal relief joints at the end of the approach slabs.
5. Replace preformed joint seal with silicone joint seal.
6. Apply concrete sealer to bridge deck, parapets, approach slabs, abutments seats and backwalls.



EXPIRATION DATE 11-30-10
DATE 11/16/09

GENERAL PLAN AND ELEVATION
I-290 OVER WOLF ROAD
COOK COUNTY
STATION 508+12
STRUCTURE NO. 016-0086

DESIGNED	DMS
CHECKED	EFS
DRAWN	RMG
CHECKED	KWS

benesch

alfred benesch & company
Engineers - Surveyors - Planners
205 North Michigan Avenue, Suite 2400
Chicago, Illinois 60601
312-565-0450 Job No. 10050

SHEET NO. 1 4 SHEETS	F.A.I. RTE.	SECTION	COUNTY	TOTAL SHEETS	SHEET NO.
	290	(3031.1, ETC., 3838)RS-5	COOK	298	231
FED. ROAD DIST. NO.			ILLINOIS	FED. AID PROJECT	
				CONTRACT NO. 60G52	

STATE OF ILLINOIS
DEPARTMENT OF TRANSPORTATION

GENERAL NOTES

1. Reinforcement bars shall conform to the requirements of ASTM A 706 Gr 60. See Special Provisions.
2. Reinforcement bars designated (E) shall be epoxy coated.
3. Plan dimensions and details relative to existing plans are subject to nominal construction variations. The Contractor shall field verify existing dimensions and details affecting new construction and make necessary approved adjustments prior to construction or ordering of materials. Such variations shall not be cause for additional compensation for a change in scope of the work, however, the Contractor will be paid for the quantity actually furnished at the unit price bid for the work.
4. Concrete Sealer shall be applied to the bridge deck, parapets, approach slabs, abutment seats and abutment backwalls. All surfaces to be sealed shall be cleaned thoroughly prior to sealer application. Cost included in Concrete Sealer.
5. The existing structural steel coating contains lead. The Contractor shall take appropriate precautions to deal with the presence of lead on this project.
6. Stage construction shall be utilized to maintain traffic during construction.

INDEX OF SHEETS

1. General Plan and Elevation
2. General Notes, Bill of Material and Index of Sheets
3. Stage Construction Details
4. Bridge Deck, Approach Slab and Parapet Repairs

TOTAL BILL OF MATERIAL

ITEM	UNIT	SUPER	SUB	TOTAL
Protective Shield	Sq. Yd.	127		127
Concrete Sealer	Sq. Ft.	26,094	1,280	27,374
Silicone Joint Sealer	Foot	237.0		237.0
Structural Repair of Concrete (Depth Greater Than 5 Inches)	Sq. Ft.	10		10
Approach Slab Repair (Partial Depth)	Sq. Yd.	20.6		20.6
Deck Slab Repair (Partial)	Sq. Yd.	38.3		38.3
Cleaning and Painting Exposed Rebar (Special)	Sq. Ft.	10		10
Clean & Reseal Relief Joint	Foot	144.0		144.0

**GENERAL NOTES, BILL OF MATERIAL
AND INDEX OF SHEETS
STRUCTURE NO. 016-0086**

DESIGNED	DMS
CHECKED	EFS
DRAWN	RMG
CHECKED	KWS

benesch

alfred benesch & company
Engineers • Surveyors • Planners
205 North Michigan Avenue, Suite 2400
Chicago, Illinois 60601
312-565-0450 Job No. 10050

SHEET NO. 2	F.A.I. RTE.	SECTION	COUNTY	TOTAL SHEETS	SHEET NO.
	290	(3031.1, ETC., 3838)RS-5	COOK	298	232
4 SHEETS	CONTRACT NO. 60G52				
FED. ROAD DIST. NO.		ILLINOIS	FED. AID PROJECT		

STATE OF ILLINOIS
DEPARTMENT OF TRANSPORTATION

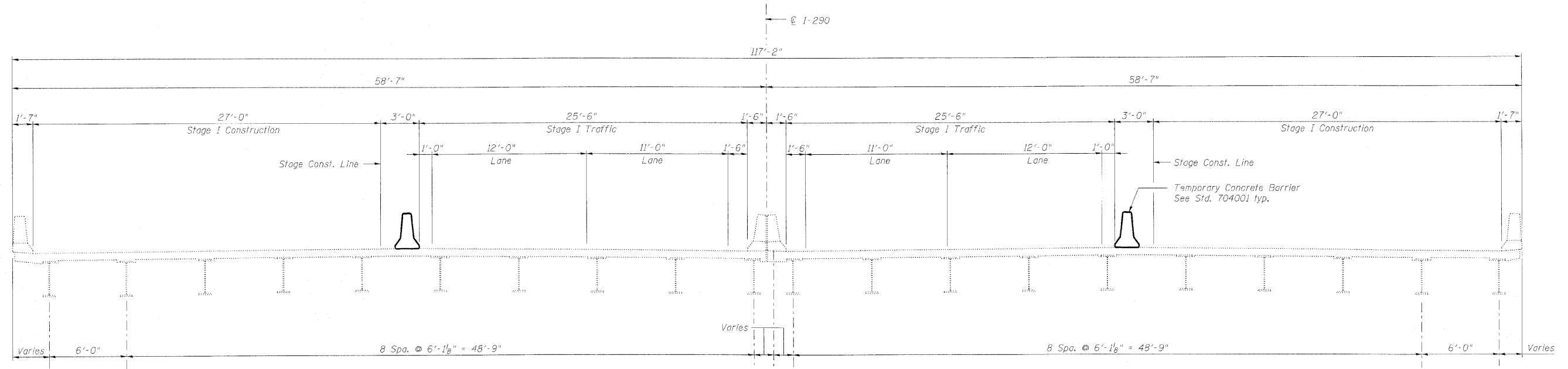

STAGE I CROSS SECTION
(Looking East)

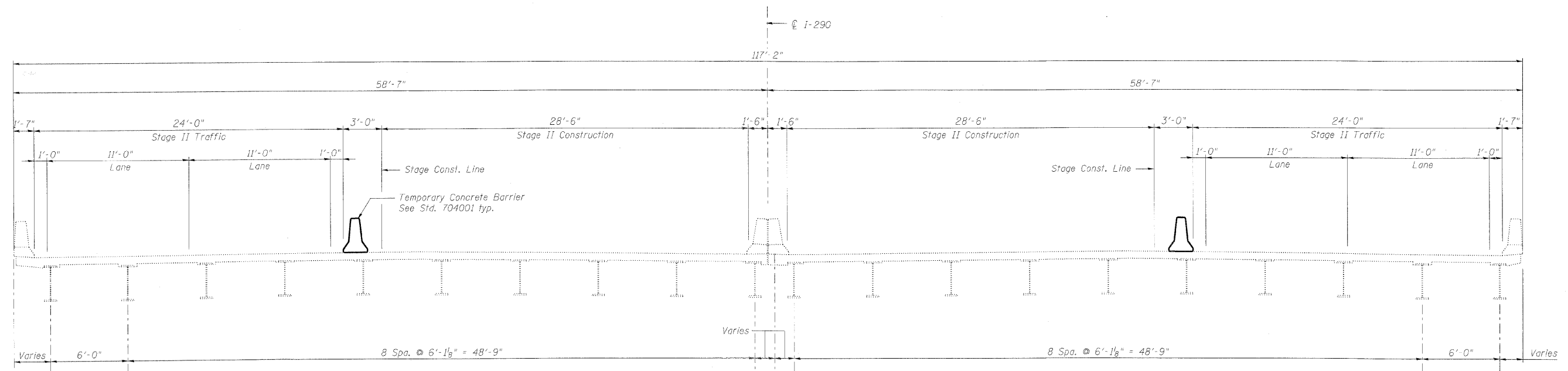

STAGE II CROSS SECTION
(Looking East)

Note:

For quantity of Temporary Concrete Barrier, see roadway plans.

STAGE CONSTRUCTION DETAILS
STRUCTURE NO. 016-0086

DESIGNED -	DMS
CHECKED -	MFB
DRAWN -	VH
CHECKED -	MFB

benesch

alfred benesch & company
Engineers • Surveyors • Planners
205 North Michigan Avenue, Suite 2400
Chicago, Illinois 60601
312-565-0450 Job No. 10050

SHEET NO. 3 4 SHEETS	F.A.I. RTE.	SECTION	COUNTY	TOTAL SHEETS	SHEET NO.
	290	(3031.1, ETC., 3838)RS-5	COOK	298	233
FED. ROAD DIST. NO.			ILLINOIS	FED. AID PROJECT	
CONTRACT NO. 60G52					

STATE OF ILLINOIS
DEPARTMENT OF TRANSPORTATION

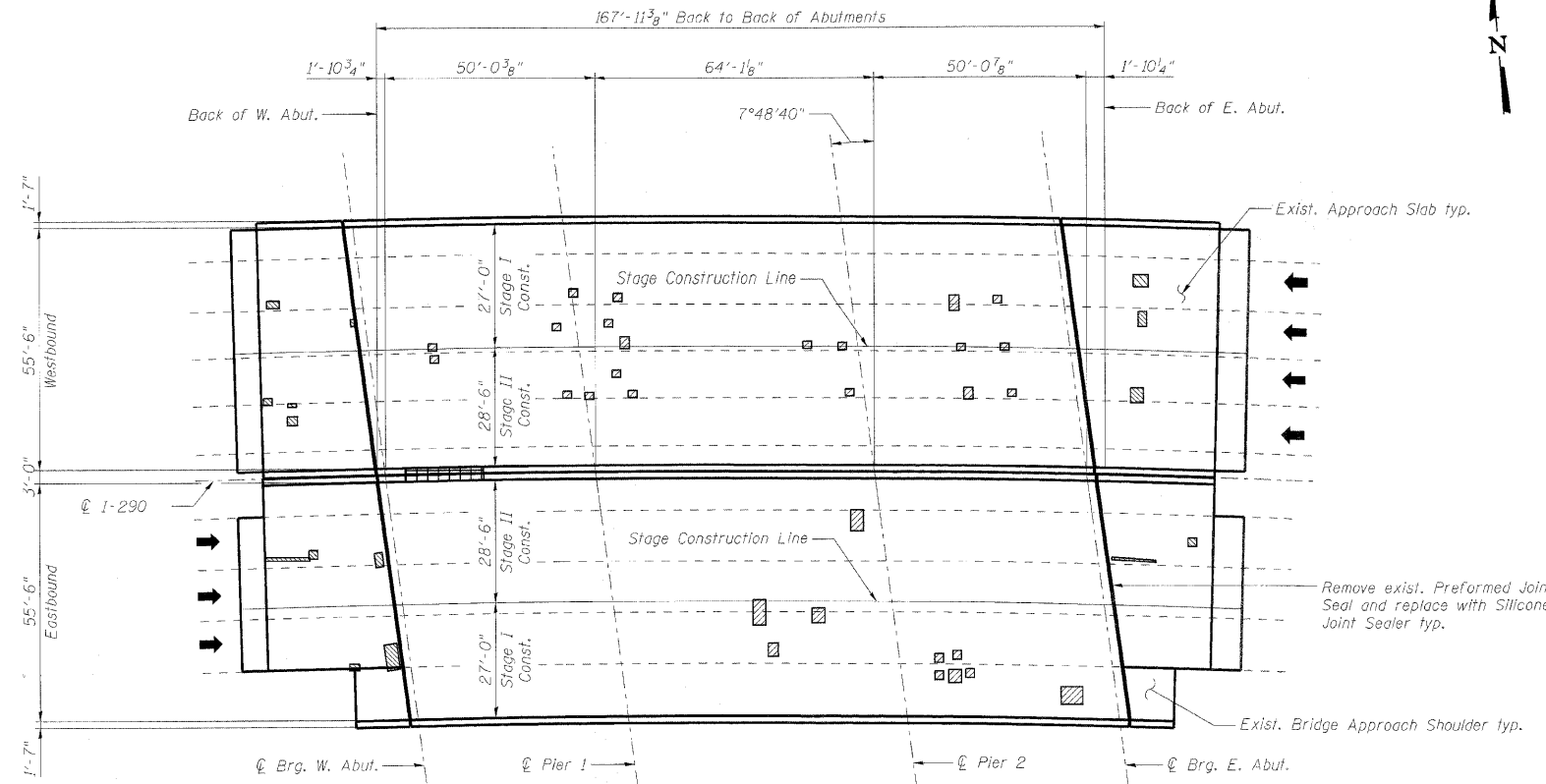

PLAN

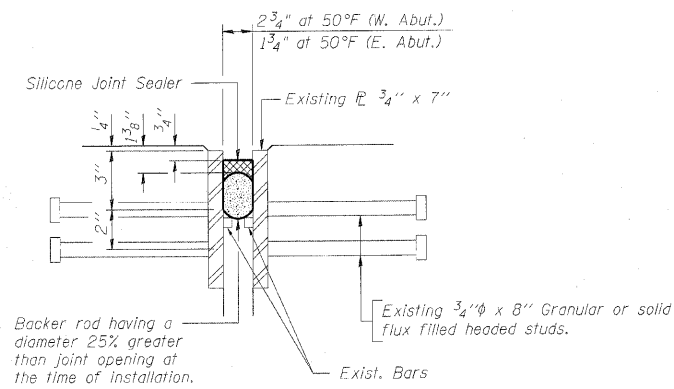

SILICONE JOINT SEALER DETAIL

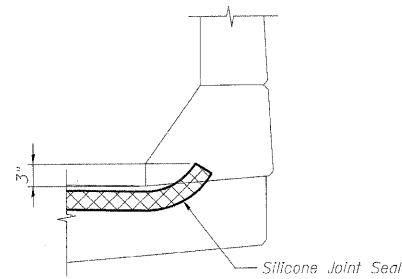

SILICONE JOINT SEAL TREATMENT AT PARAPET

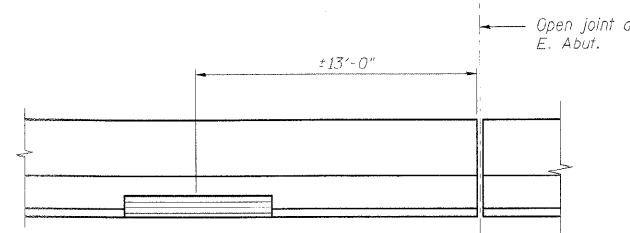

INSIDE ELEVATION - EASTBOUND MEDIAN PARAPET

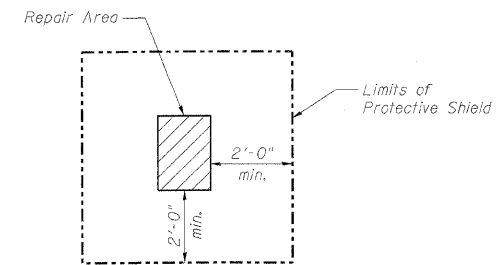

PROTECTIVE SHIELD DETAIL

BILL OF MATERIAL

Symbol	Item	Unit	Quantity
	Deck Slab Repair (Partial)	Sq. Yd.	38.3
	Approach Slab Repair (Partial Depth)	Sq. Yd.	20.6
	Structural Repair of Concrete (Depth Greater Than 5 Inches)	Sq. Ft.	10
	Cleaning & Painting Exposed Rebar (Special)	Sq. Ft.	10
	Protective Shield	Sq. Yd.	127
	Silicone Joint Sealer	Foot	237.0

Notes:

- Deck and approach slab repair areas are estimated based on visual inspection completed in June 2009. Actual repair areas and locations shall be determined by the Engineer and shown on As-Built plans.
- Protective Shield, required for deck slab and/or parapet repairs, shall be installed according to Article 501.03 of the Standard Specifications. For limits of Protective Shield, see Protective Shield Detail on this sheet and Elevation on General Plan and Elevation sheet.
- The Engineer shall determine extent, location & type of parapet repairs in the field. Actual repair areas and locations shall be determined by the Engineer and shown on As-Built plans.
- Existing Preformed Joint Seal shall be removed and all surfaces cleaned prior to installation of Silicone Joint Sealer. Cost included in Silicone Joint Sealer.
- The Contractor shall exercise extreme care with the existing conduit in sections of the parapet to be repaired and to protect and support the conduit. The Contractor will be required to repair any damage done to the conduit to the satisfaction of the Engineer. No splicing will be allowed to any cable damage resulting from this work, instead the Contractor will be required to repair the entire span of any damaged cable at no additional cost to the Department.

BRIDGE DECK,
APPROACH SLAB AND PARAPET REPAIRS
STRUCTURE NO. 016-0086

DESIGNED	DMS
CHECKED	EFS
DRAWN	RMG
CHECKED	KWS

benesch

alfred benesch & company
Engineers • Surveyors • Planners
205 North Michigan Avenue, Suite 2400
Chicago, Illinois 60601
312-565-0450 Job No. 10050

SHEET NO. 4 4 SHEETS	F.A.I. RTE.	SECTION	COUNTY	TOTAL SHEETS	SHEET NO.
	290	(3031.1, ETC., 3838)RS-5	COOK	298	234
FED. ROAD DIST. NO.			ILLINOIS	FED. AID PROJECT	
CONTRACT NO. 60G52					

STATE OF ILLINOIS
DEPARTMENT OF TRANSPORTATION

Existing Structure:
Existing Bridge No. 016-2758 was built in 2001. The structure is a three-span continuous, composite steel bridge with a 7 1/2" concrete deck.

Stage construction shall be utilized to maintain traffic during construction.

No salvage

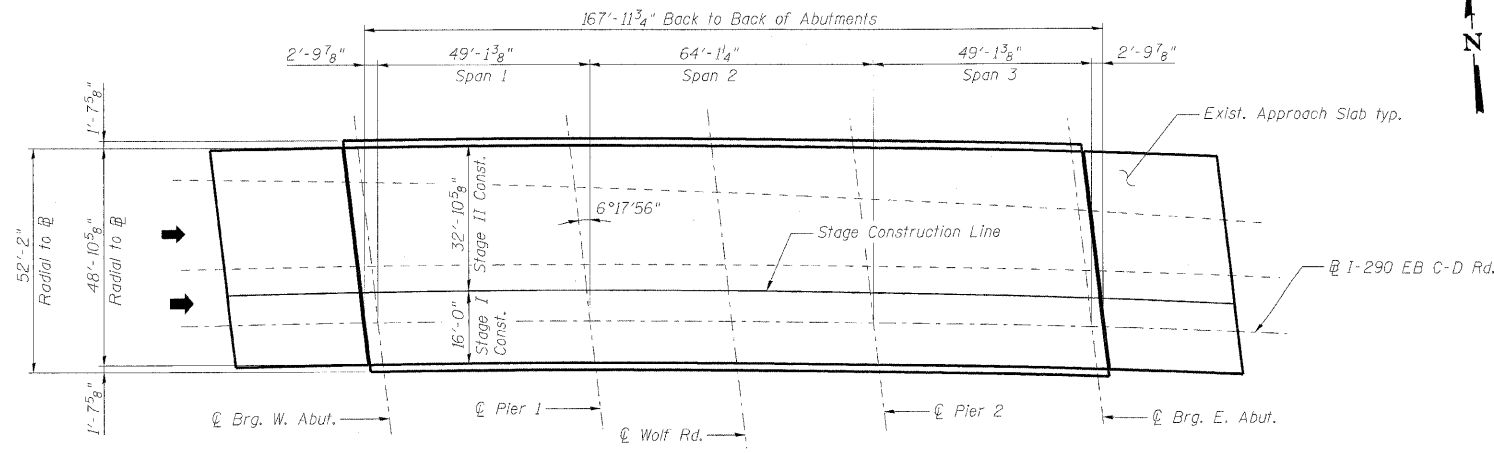

PLAN

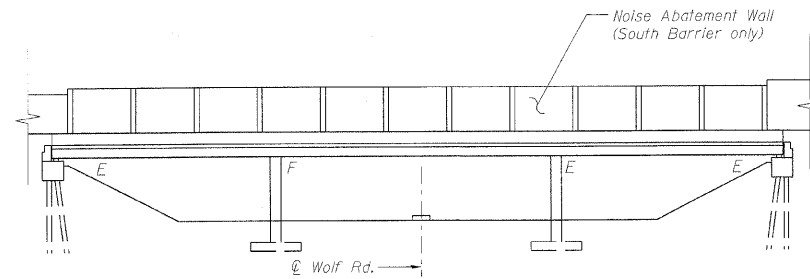

ELEVATION

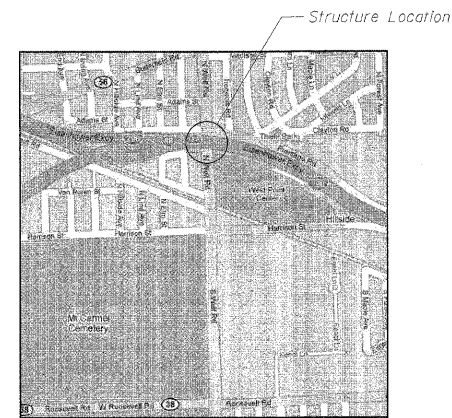

LOCATION SKETCH



EXPIRATION DATE: 11-30-10
DATE: 11/16/09

TOTAL BILL OF MATERIAL

ITEM	UNIT	SUPER	SUB	TOTAL
Concrete Sealer	Sq. Ft.	12,524		12,524

DESIGN SPECIFICATIONS

2002 AASHTO Standard Specifications for Highway Bridges, 17th Edition

DESIGN STRESSES

f'c = 3,500 psi
fy = 60,000 psi

SCOPE OF WORK

Apply concrete sealer to bridge deck, parapets and approach slabs.

GENERAL NOTES

- Plan dimensions and details relative to existing plans are subject to nominal construction variations. The Contractor shall field verify existing dimensions and details affecting new construction and make necessary approved adjustments prior to construction or ordering of materials. Such variations shall not be cause for additional compensation for a change in scope of the work, however, the Contractor will be paid for the quantity actually furnished at the unit price bid for the work.
- Concrete Sealer shall be applied to the bridge deck, parapets, and approach slabs. All surfaces to be sealed shall be cleaned thoroughly prior to sealer application. Cost included in Concrete Sealer.
- Stage construction shall be utilized to maintain traffic during construction.

GENERAL PLAN AND ELEVATION
I-290 EB C-D ROAD OVER WOLF ROAD
COOK COUNTY
STATION 507+54
STRUCTURE NO. 016-2758

DESIGNED	-	DMS
CHECKED	-	EFS
DRAWN	-	RMG
CHECKED	-	KWS

benesch

alfred benesch & company
Engineers • Surveyors • Planners
205 North Michigan Avenue, Suite 2400
Chicago, Illinois 60601
312-565-0450 Job No. 10050

SHEET NO. 1	F.A.I. RTE.	SECTION	COUNTY	TOTAL SHEETS	SHEET NO.
1 SHEETS	290	(3031.1, ETC., 3838)RS-5	COOK	298	235
FED. ROAD DIST. NO.			ILLINOIS	FED. AID PROJECT	
CONTRACT NO. 60G52					

STATE OF ILLINOIS
DEPARTMENT OF TRANSPORTATION

Existing Structure:
Single span WF beam bridge, with closed abutments-cantilever type
on spread footing 114'-0" wide by 36'-11" long, built as F.A. Route 131,
Section 052-3737.3 M.F.T. Sta. 79+51.60 in 1955. The bridge was
widened to 117'-2" in 1984.

Stage construction shall be utilized to maintain traffic during construction.

No salvage.

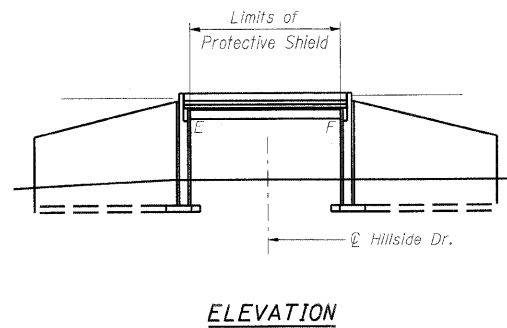
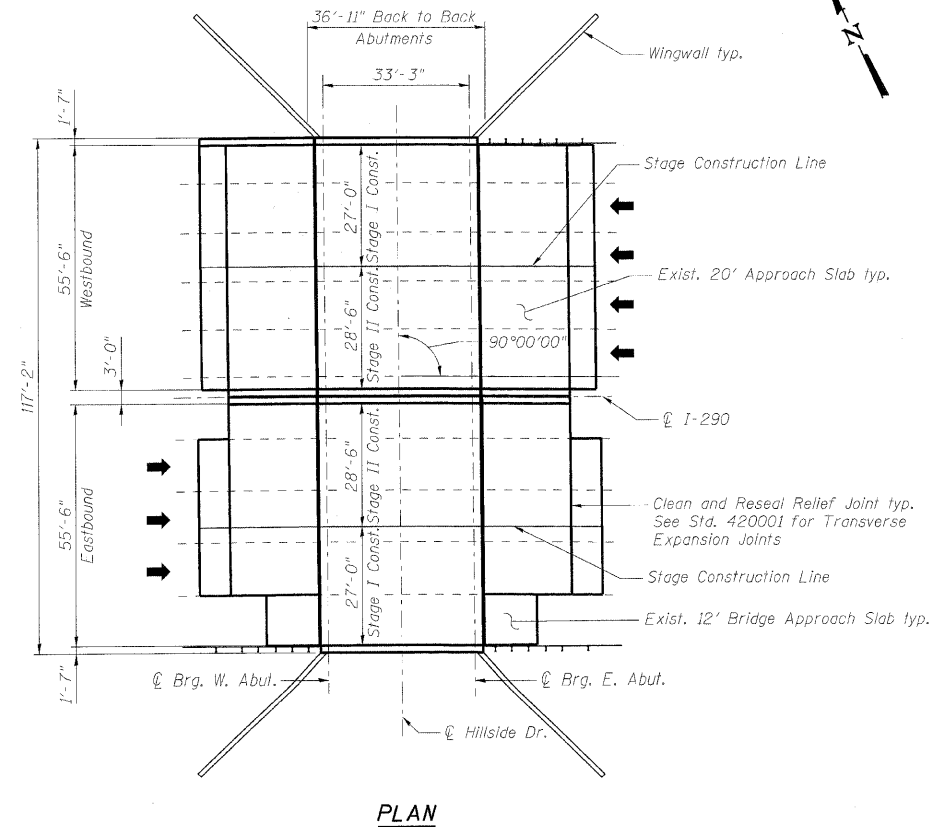

DESIGN SPECIFICATIONS

2002 AASHTO Standard Specifications
for Highway Bridges, 17th Edition

DESIGN STRESSES

$f'_c = 3,500 \text{ psi}$
 $f_y = 60,000 \text{ psi}$

SCOPE OF WORK

1. Repair bridge deck.
2. Repair approach slab.
3. Repair of abutments.
4. Clean and reseal relief joints at end of approach slabs.
5. Replace preformed joint seal with silicone joint seal.
6. Apply concrete sealer to bridge decks, parapets, approach slabs, abutment seats and backwalls.



EXPIRATION DATE 11-30-10
DATE 11/16/09

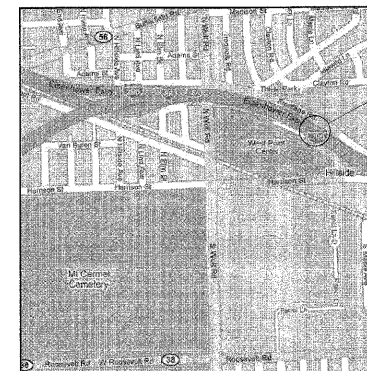

LOCATION SKETCH

GENERAL PLAN AND ELEVATION
I-290 OVER HILLSIDE DRIVE
COOK COUNTY
STATION 525+44
STRUCTURE NO. 016-0986

DESIGNED	DMS
CHECKED	EFB
DRAWN	RMG
CHECKED	KJN

benesch

alfred benesch & company
Engineers • Surveyors • Planners
205 North Michigan Avenue, Suite 2400
Chicago, Illinois 60601
312-565-0450 Job No. 10050

SHEET NO. 1 5 SHEETS	F.A.I. RTE.	SECTION	COUNTY	TOTAL SHEETS	SHEET NO.
	290	(3031.1, ETC., 3838)RS-5	COOK	298	236
FED. ROAD DIST. NO.			ILLINOIS	FED. AID PROJECT	
CONTRACT NO. 60G52					

STATE OF ILLINOIS
DEPARTMENT OF TRANSPORTATION

GENERAL NOTES

1. Reinforcement bars shall conform to the requirements of ASTM A 706 Gr 60. See Special Provisions.
2. Plan dimensions and details relative to existing plans are subject to nominal construction variations. The Contractor shall field verify existing dimensions and details affecting new construction and make necessary approved adjustments prior to construction or ordering of materials. Such variations shall not be cause for additional compensation for a change in scope of the work, however, the Contractor will be paid for the quantity actually furnished at the unit price bid for the work.
3. Concrete Sealer shall be applied to the bridge deck, parapets, approach slabs, abutment seats and abutment backwalls. All surfaces to be sealed shall be cleaned thoroughly prior to sealer application. Cost included in Concrete Sealer.
4. The existing structural steel coating contains lead. The Contractor shall take appropriate precautions to deal with the presence of lead on this project.
5. Stage construction shall be utilized to maintain traffic during construction.
6. The Contractor shall exercise care during removal of existing joints to ensure that the slab, beams and diaphragms integrity will not be detrimentally impacted. The Contractor shall repair any damage(s) to the slab, beams and diaphragms caused by his operation as directed by the Engineer at no additional cost to the Department.

INDEX OF SHEETS

1. General Plan and Elevation
2. General Notes, Bill of Material and Index of Sheets
3. Stage Construction Details
4. Bridge Deck and Approach Slab Repairs
5. Abutment Repair Details

TOTAL BILL OF MATERIAL

ITEM	UNIT	SUPER	SUB	TOTAL
Protective Shield	Sq. Yd.	85		85
Concrete Sealer	Sq. Ft.	8,588	790	9,378
Silicone Joint Sealer	Foot	222.0		222.0
Structural Repair of Concrete (Depth Equal to or Less Than 5 Inches)	Sq. Ft.		50	50
Approach Slab Repair (Partial Depth)	Sq. Yd.	20.0		20.0
Deck Slab Repair (Partial)	Sq. Yd.	10.0		10.0
Temporary Shoring & Cribbing	Each		6	6
Clean & Reseal Relief Joint	Foot	144.0		144.0

**GENERAL NOTES, BILL OF MATERIAL
AND INDEX OF SHEETS
STRUCTURE NO. 016-0986**

DESIGNED -	DMS
CHECKED -	EFS
DRAWN -	RMG
CHECKED -	KJN

benesch

alfred benesch & company
Engineers • Surveyors • Planners
205 North Michigan Avenue, Suite 2400
Chicago, Illinois 60601
312-565-0450 Job No. 10050

SHEET NO. 2	F.A.I. RTE.	SECTION	COUNTY	TOTAL SHEETS	SHEET NO.
	290	(3031.1, ETC., 3838)RS-5	COOK	298	237
5 SHEETS	CONTRACT NO. 60G52				
FED. ROAD DIST. NO.		ILLINOIS	FED. AID PROJECT		

STATE OF ILLINOIS
DEPARTMENT OF TRANSPORTATION

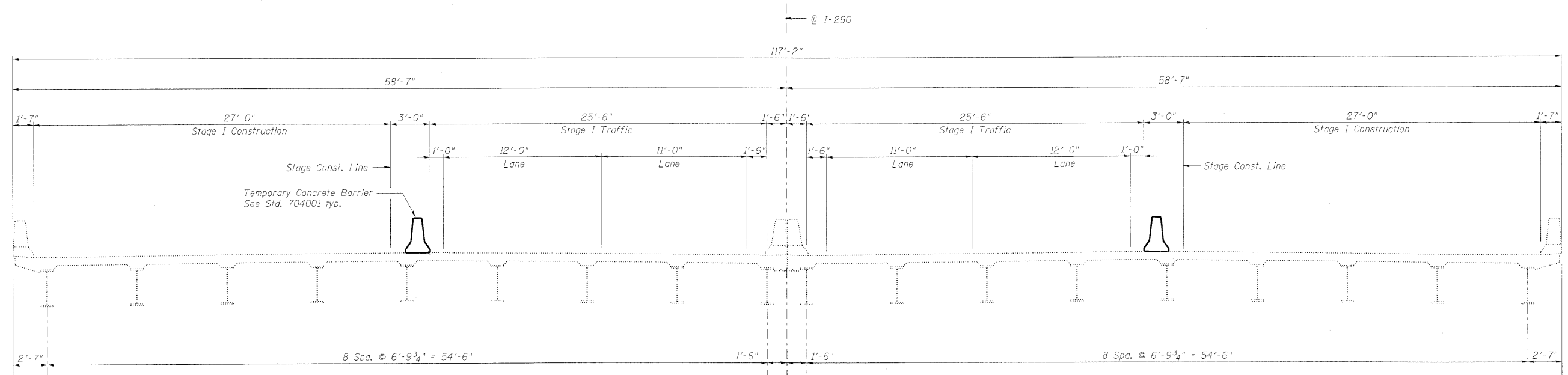

STAGE I CROSS SECTION
(Looking East)

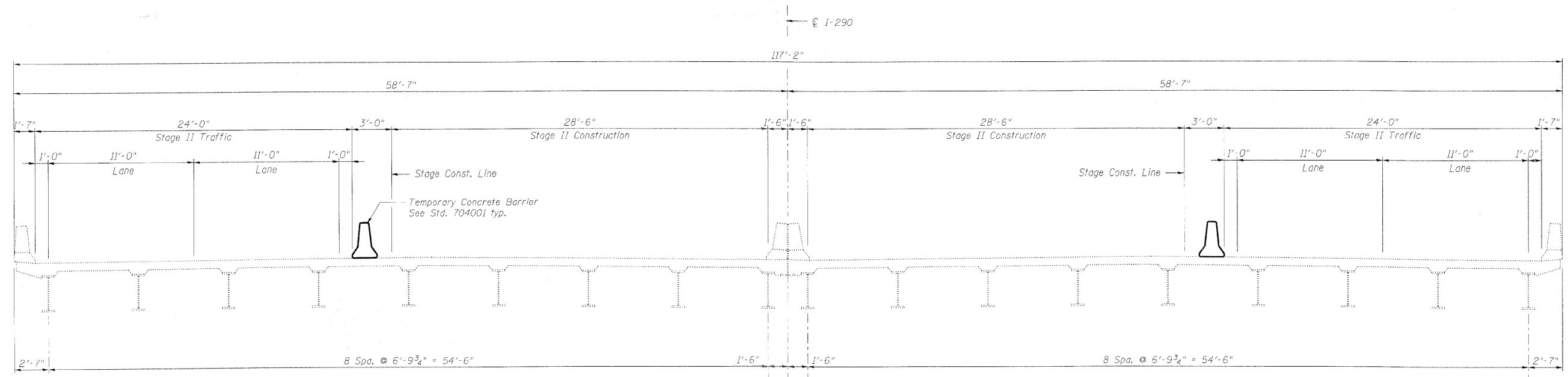

STAGE II CROSS SECTION
(Looking East)

Note:
For quantity of Temporary Concrete Barrier, see roadway plans.

STAGE CONSTRUCTION DETAILS
STRUCTURE NO. 016-0986

DESIGNED	DMS
CHECKED	MFB
DRAWN	VH
CHECKED	KJN

benesch

alfred benesch & company
Engineers • Surveyors • Planners
205 North Michigan Avenue, Suite 2400
Chicago, Illinois 60601
312-565-0450 Job No. 10050

SHEET NO. 3 5 SHEETS	F.A.I. RTE.	SECTION	COUNTY	TOTAL SHEETS	SHEET NO.
	290	(3031.1, ETC., 3838)RS-5	COOK	298	238
FED. ROAD DIST. NO.			ILLINOIS	FED. AID PROJECT	
CONTRACT NO. 60G52					

STATE OF ILLINOIS
DEPARTMENT OF TRANSPORTATION

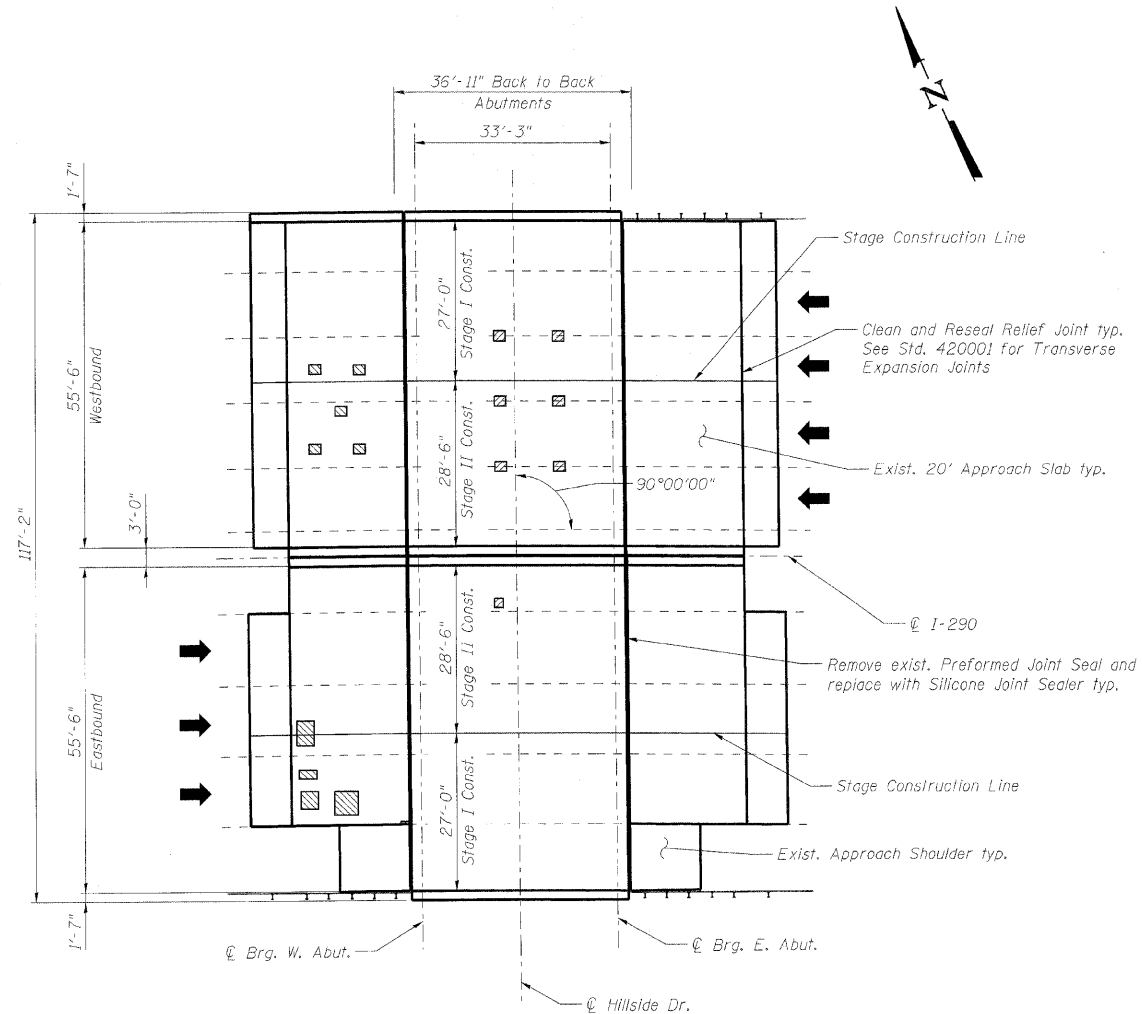

PLAN

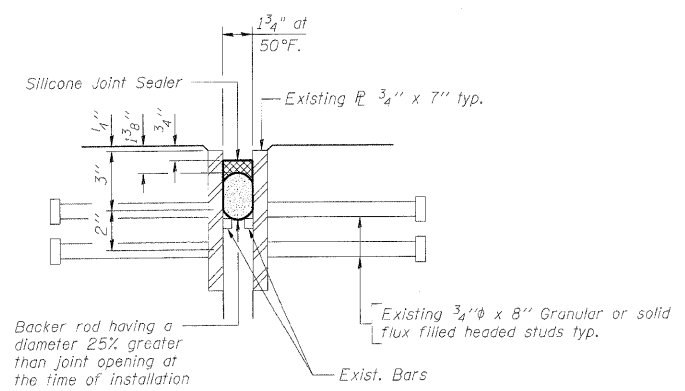

SILICONE JOINT SEALER DETAIL

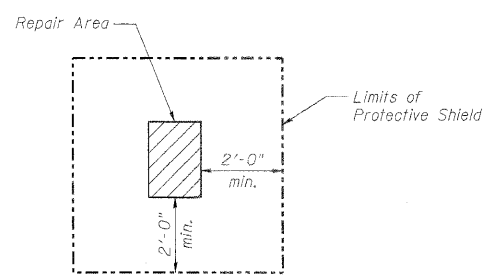

PROTECTIVE SHIELD DETAIL

BILL OF MATERIAL

Symbol	Item	Unit	Quantity
	Deck Slab Repair (Partial)	Sq. Yd.	10.0
	Approach Slab Repair (Partial Depth)	Sq. Yd.	20.0
	Protective Shield	Sq. Yd.	85
	Silicone Joint Sealer	Foot	222.0

Notes:

- Deck and approach slab repair areas are estimated based on visual inspection completed in June 2009. Actual repair areas and locations shall be determined by the Engineer in the field and shown on the As-Built plans.
- Protective Shield, required for deck slab and/or parapet repairs, shall be installed according to Article 501.03 of the Standard Specifications. For limits of Protective Shield, see Protective Shield Detail on this sheet and Elevation on General Plan and Elevation detail.
- Existing Preformed Joint Seal shall be removed and all surfaces cleaned prior to installation of Silicone Joint Sealer. Cost included in Silicone Joint Sealer.

BRIDGE DECK
AND APPROACH SLAB REPAIRS
STRUCTURE NO. 016-0986

DESIGNED -	DMS
CHECKED -	EF5
DRAWN -	RMG
CHECKED -	KJN

benesch

alfred benesch & company
Engineers • Surveyors • Planners
205 North Michigan Avenue, Suite 2400
Chicago, Illinois 60601
312-585-0450 Job No. 10050

SHEET NO. 4 5 SHEETS	F.A.I. RTE.	SECTION	COUNTY	TOTAL SHEETS	SHEET NO.
	290	(3031.1, ETC., 3838)RS-5	COOK	298	239
FED. ROAD DIST. NO.			ILLINOIS	FED. AID PROJECT	
CONTRACT NO. 60G52					

STATE OF ILLINOIS
DEPARTMENT OF TRANSPORTATION

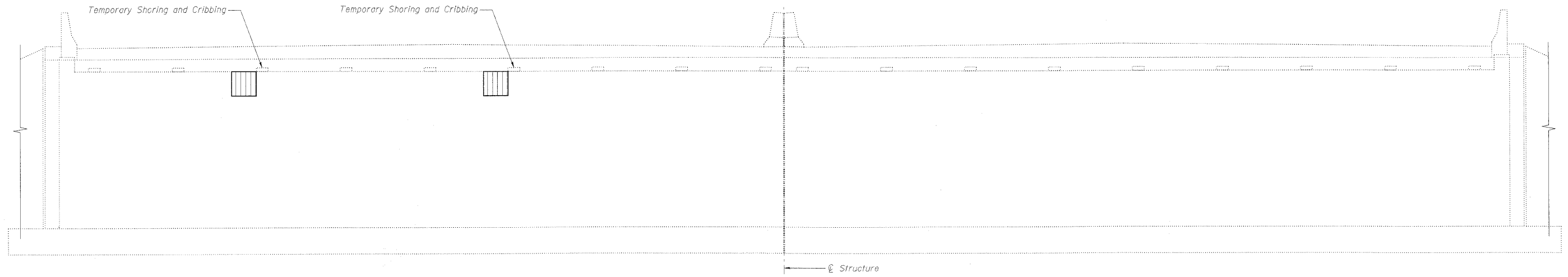

EAST ABUTMENT ELEVATION
(Looking East)

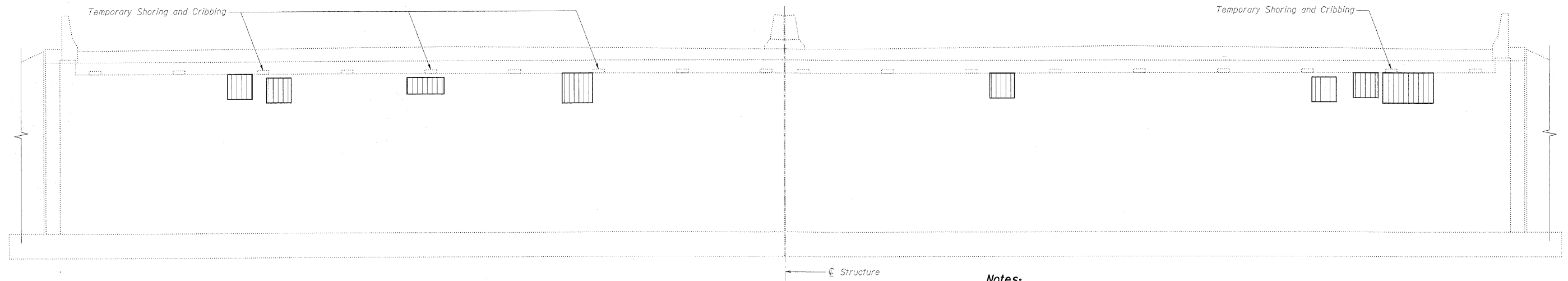

WEST ABUTMENT ELEVATION
(Looking West)

BILL OF MATERIAL

Symbol	Item	Unit	Quantity
	Structural Repair of Concrete (Depth Equal to or Less than 5 inches)	Sq. Ft.	50
	Temporary Shoring and Cribbing	Each	6

BEAM REACTIONS (KIPS)

DEAD LOAD	LIVE LOAD	IMPACT LOAD	TOTAL
17.5	32.0	9.6	59.1

Notes:

- The abutment repairs are estimated based on visual inspections completed in June 2009.
- Temporary Shoring and Cribbing shall be provided per the Special Provisions for "Structural Repair of Concrete" and "Temporary Shoring and Cribbing".
- Interference is expected from existing conduits. The Contractor shall remove and reerect or temporarily support the existing conduits to complete the work as detailed. When the work is completed the conduits shall be reconnected to the reconstructed abutment or pier utilizing the existing mounting brackets or new mounting brackets. All labor, equipment, and materials necessary for removing and reinstalling or temporarily supporting the existing conduits shall be included in the cost for Structural Repair of Concrete (Depth Equal to or Less than 5 Inches).
- The tabulated beam reactions were taken from the existing construction plans. The Contractor shall verify that the equipment used to support the beams is sufficient to carry these loads in addition to any temporary construction loads.

ABUTMENT REPAIR DETAILS
STRUCTURE NO. 016-0986

DESIGNED -	DMS
CHECKED -	EFS
DRAWN -	RMG
CHECKED -	KJN

benesch

alfred benesch & company
Engineers - Surveyors - Planners
205 North Michigan Avenue, Suite 2400
Chicago, Illinois 60601
312-565-0450 Job No. 10050

SHEET NO. 5 5 SHEETS	F.A.I. RTE.	SECTION	COUNTY	TOTAL SHEETS	SHEET NO.
		(3031.1, ETC., 3838)RS-5	COOK	298	240
FED. ROAD DIST. NO.			ILLINOIS	FED. AID PROJECT	
			CONTRACT NO. 60G52		

STATE OF ILLINOIS
DEPARTMENT OF TRANSPORTATION

Existing Structure:
Existing Bridge No. 016-2759 was built in 2002. The structure is a simple span composite steel bridge with a 7 1/2" concrete deck.

Stage construction shall be utilized to maintain traffic during construction.

No salvage

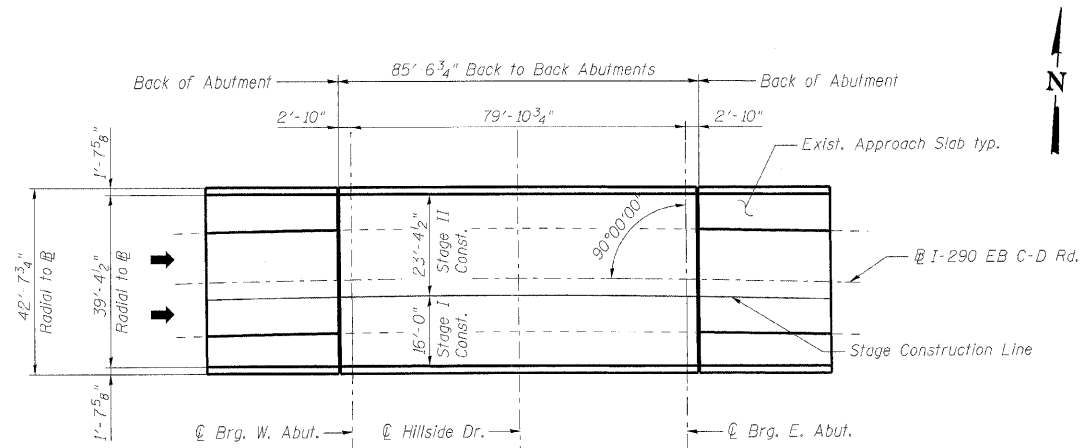

PLAN

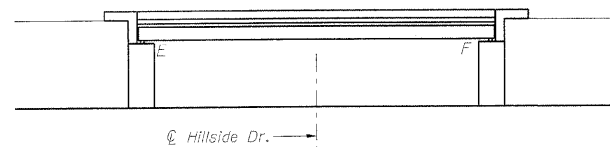

ELEVATION

TOTAL BILL OF MATERIAL

ITEM	UNIT	SUPER	SUB	TOTAL
Concrete Sealer	Sq. Ft.	5,442		5,442

DESIGN SPECIFICATIONS

2002 AASHTO Standard Specifications
for Highway Bridges, 17th Edition

DESIGN STRESSES

$f'_c = 3,500$ psi
 $f_y = 60,000$ psi

SCOPE OF WORK

Apply concrete sealer to bridge deck, parapets and approach slabs.

GENERAL NOTES

- Plan dimensions and details relative to existing plans are subject to nominal construction variations. The Contractor shall field verify existing dimensions and details affecting new construction and make necessary approved adjustments prior to construction or ordering of materials. Such variations shall not be cause for additional compensation for a change in scope of the work, however, the Contractor will be paid for the quantity actually furnished at the unit price bid for the work.
- Concrete Sealer shall be applied to the bridge deck, parapets, and approach slabs. All surfaces to be sealed shall be cleaned thoroughly prior to sealer application. Cost included in Concrete Sealer.
- Stage construction shall be utilized to maintain traffic during construction.

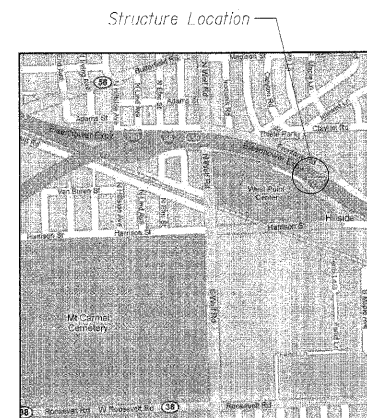

LOCATION SKETCH

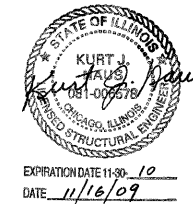

GENERAL PLAN AND ELEVATION
I-290 EB C-D ROAD OVER HILLSIDE DRIVE
COOK COUNTY
STATION 524+16
STRUCTURE NO. 016-2759

DESIGNED	DMS
CHECKED	EFS
DRAWN	RMG
CHECKED	KWS

benesch

alfred benesch & company
Engineers • Surveyors • Planners
205 North Michigan Avenue, Suite 2400
Chicago, Illinois 60601
312-565-0450 Job No. 10050

SHEET NO. 1	F.A.I. RTE.	SECTION	COUNTY	TOTAL SHEETS	SHEET NO.
1 SHEETS	290	(3031.1, ETC., 3838)RS-5	COOK	298	241
FED. ROAD DIST. NO.			ILLINOIS	FED. AID PROJECT	
CONTRACT NO. 60G52					

Existing Structure:
 Existing Bridge No. 016-0088 at Sta. 138+88.93 was built in 1952 as
 F.A. Rte. 131-Project U.I. 261(17) Section 062-3636.2 M.F.T. It is a
 three span continuous reinforced concrete slab Bridge, 107'-6" bk. to bk.
 abutments. The Bridge was widened to 130'-9" O. to O. in 2001.

Stage Construction shall be utilized to maintain traffic during construction.

No salvage.

STATE OF ILLINOIS
 DEPARTMENT OF TRANSPORTATION

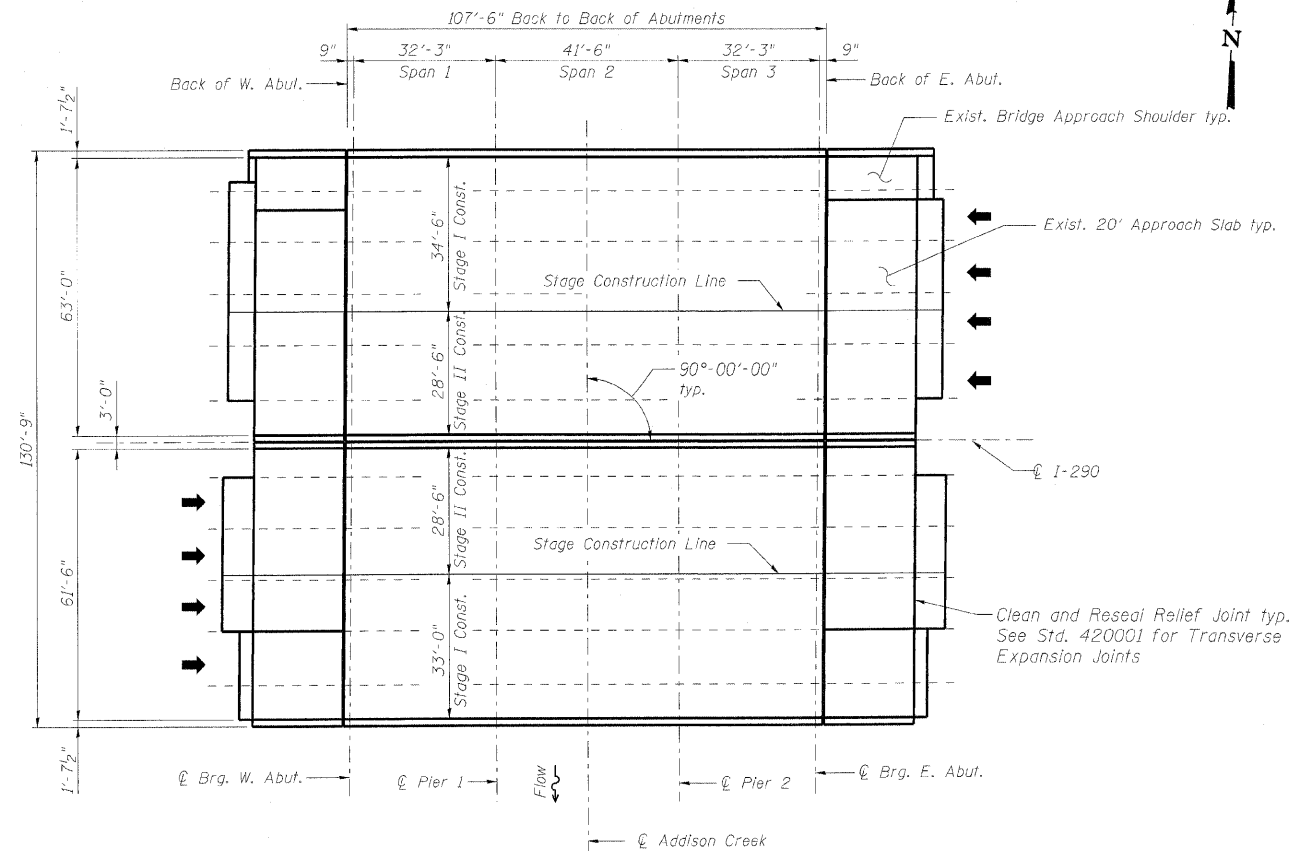

PLAN

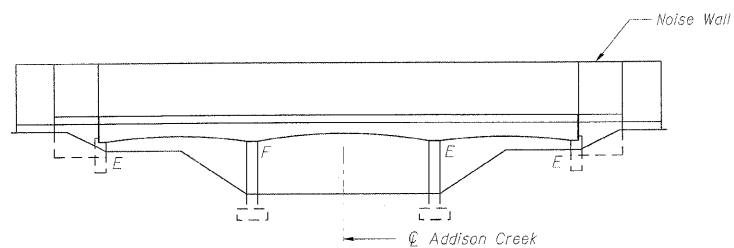

ELEVATION

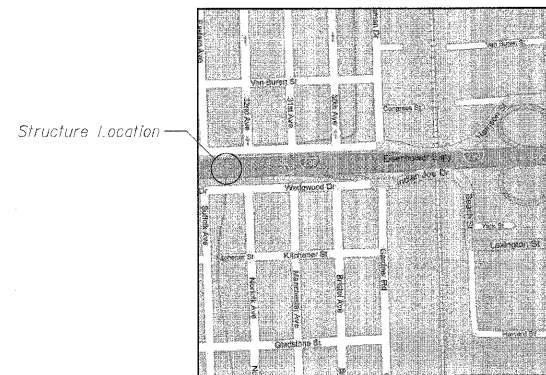

LOCATION SKETCH

DESIGN SPECIFICATIONS

2002 AASHTO Standard Specifications
 for Highway Bridges, 17th Edition

DESIGN STRESSES

$f'_c = 3,500$ psi
 $f_y = 60,000$ psi

SCOPE OF WORK

1. Repair bridge decks.
2. Repair approach slabs.
3. Repair median parapets with formed concrete repair.
4. Clean and reseal relief joints at end of approach slabs.
5. Replace preformed joint seals with silicone joint seals.
6. Apply concrete sealer to bridge decks, parapets, approach slabs, abutment seats and backwalls.



EXPIRATION DATE 11-30-10
 DATE 11/16/09

GENERAL PLAN AND ELEVATION
 I-290 OVER ADDISON CREEK
 COOK COUNTY
 STATION 594+10
 STRUCTURE NO. 016-0088

DESIGNED	DMS
CHECKED	EFS
DRAWN	RMG
CHECKED	KJN

benesch

alfred benesch & company
 Engineers • Surveyors • Planners
 205 North Michigan Avenue, Suite 2400
 Chicago, Illinois 60601
 312-565-0450 Job No. 10050

SHEET NO. 1 4 SHEETS	F.A.I. RTE.	SECTION	COUNTY	TOTAL SHEETS	SHEET NO.
	290	(3031.1, ETC., 3838)RS-5	COOK	298	242
FED. ROAD DIST. NO.			ILLINOIS	FED. AID PROJECT	
CONTRACT NO. 60G52					

x:\100000\10050\Engineering_Documents_Contract\2\SN\016_0088_Addison_Creek\0088-60G52-001-gpr.dgn 17:50:30 11/12/2009

STATE OF ILLINOIS
DEPARTMENT OF TRANSPORTATION

GENERAL NOTES

1. Reinforcement bars shall conform to the requirements of ASTM A 706 Gr 60. See Special Provisions.
2. Plan dimensions and details relative to existing plans are subject to nominal construction variations. The Contractor shall field verify existing dimensions and details affecting new construction and make necessary approved adjustments prior to construction or ordering of materials. Such variations shall not be cause for additional compensation for a change in scope of the work, however, the Contractor will be paid for the quantity actually furnished at the unit price bid for the work.
3. Concrete Sealer shall be applied to the bridge deck, top and inside faces of parapets, approach slabs, abutment seats and abutment backwalls. All surfaces to be sealed shall be cleaned thoroughly prior to sealer application. Cost included in Concrete Sealer.
4. Stage construction shall be utilized to maintain traffic during construction.

INDEX OF SHEETS

1. General Plan and Elevation
2. General Notes, Bill of Material and Index of Sheets
3. Stage Construction Details
4. Bridge Deck and Approach Slab Repairs

TOTAL BILL OF MATERIAL

ITEM	UNIT	SUPER	SUB	TOTAL
Concrete Sealer	Sq. Ft.	18,001	600	18,601
Silicone Joint Sealer	Foot	228.0		228.0
Structural Repair of Concrete (Depth Greater Than 5 Inches)	Sq. Ft.	32		32
Approach Slab Repair (Partial Depth)	Sq. Yd.	24.4		24.4
Deck Slab Repair (Partial)	Sq. Yd.	18.6		18.6
Clean & Reseal Relief Joint	Foot	189.0		189.0

**GENERAL NOTES, BILL OF MATERIAL
AND INDEX OF SHEETS
STRUCTURE NO. 016-0088**

DESIGNED -	DMS
CHECKED -	EFS
DRAWN -	RMG
CHECKED -	KJN

benesch

alfred benesch & company
Engineers - Surveyors - Planners
205 North Michigan Avenue, Suite 2400
Chicago, Illinois 60601
312-565-0450 Job No. 10050

SHEET NO. 2	F.A.I. RTE.	SECTION	COUNTY	TOTAL SHEETS	SHEET NO.
	290	(3031.1, ETC., 3838)RS-5	COOK	298	243
4 SHEETS	CONTRACT NO. 60G52				
FED. ROAD DIST. NO.		ILLINOIS	FED. AID PROJECT		

STATE OF ILLINOIS
DEPARTMENT OF TRANSPORTATION

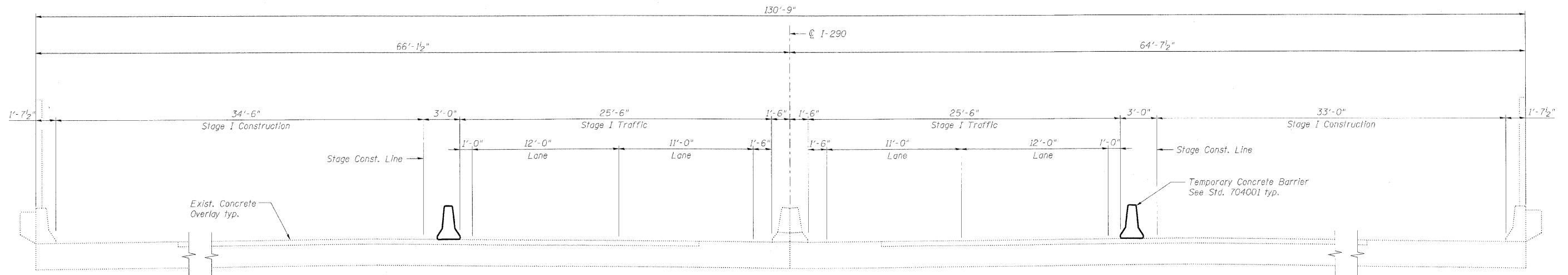

STAGE I CROSS SECTION
(Looking East)

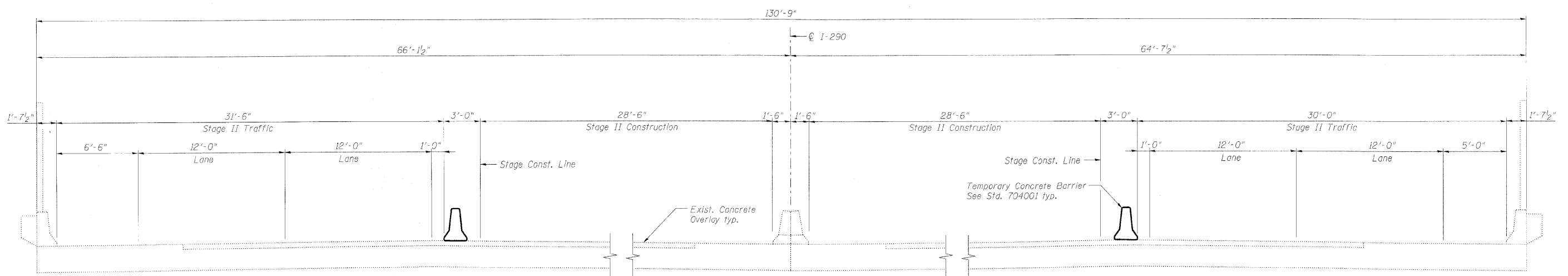

STAGE II CROSS SECTION
(Looking East)

Note:
For quantity of Temporary Concrete Barrier, see roadway plans.

STAGE CONSTRUCTION DETAILS
STRUCTURE NO. 016-0088

DESIGNED -	MFB
CHECKED -	MAC
DRAWN -	VH
CHECKED -	KJN

benesch

alfred benesch & company
Engineers • Surveyors • Planners
205 North Michigan Avenue, Suite 2400
Chicago, Illinois 60601
312-665-0450 Job No. 10050

SHEET NO. 3 4 SHEETS	F.A.I. RTE.	SECTION	COUNTY	TOTAL SHEETS	SHEET NO.
	290	(3031.1, ETC., 3838)RS-5	COOK	298	244
FED. ROAD DIST. NO.			ILLINOIS	FED. AID PROJECT	
CONTRACT NO. 60G52					

STATE OF ILLINOIS
DEPARTMENT OF TRANSPORTATION

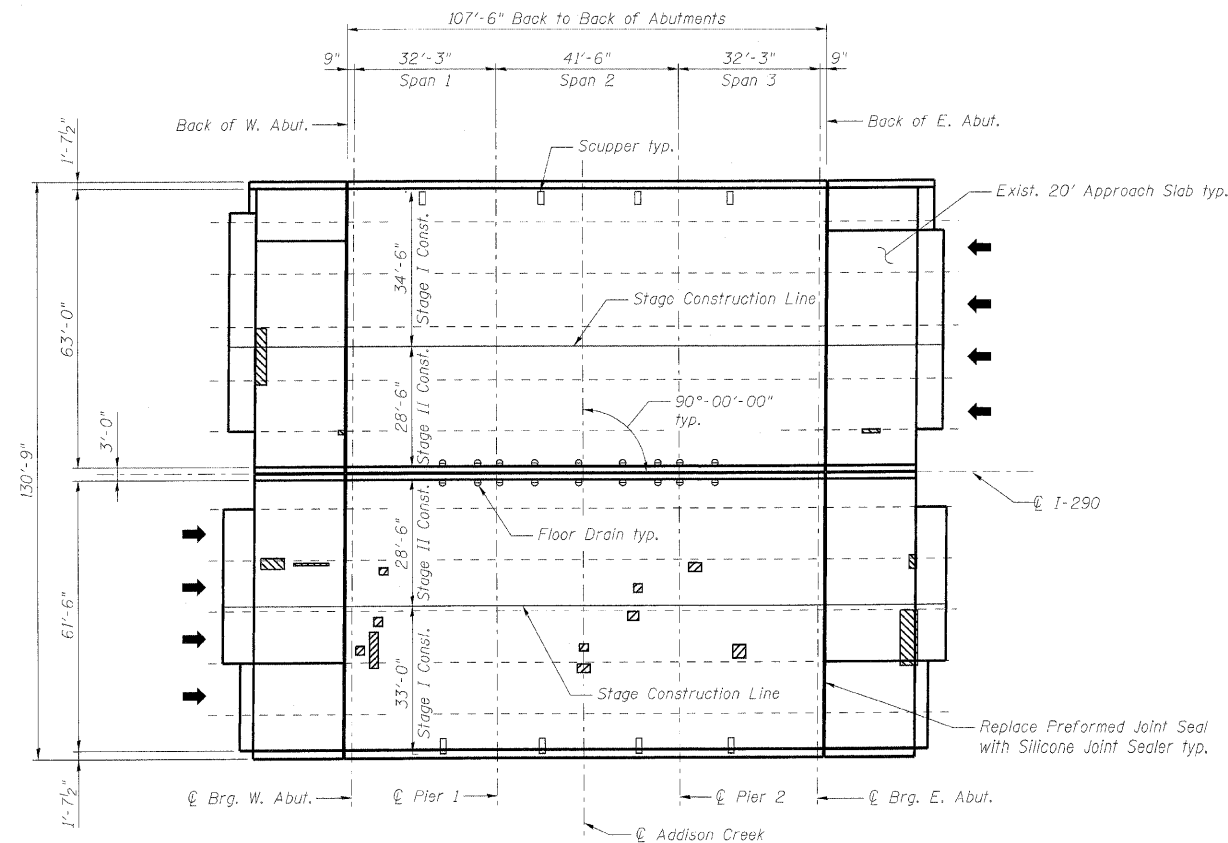
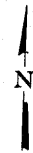

PLAN

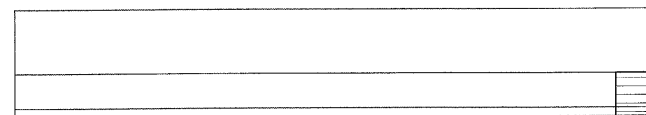

INSIDE ELEVATION - EASTBOUND MEDIAN PARAPET

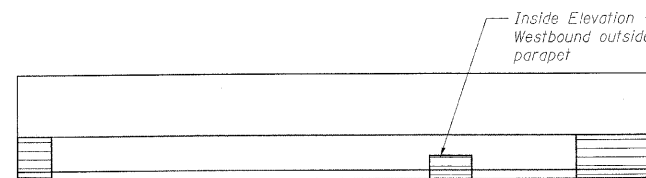

INSIDE ELEVATION - WESTBOUND MEDIAN PARAPET
(Unless Noted Otherwise)

DESIGNED	DMS
CHECKED	EFS
DRAWN	RMG
CHECKED	KJN

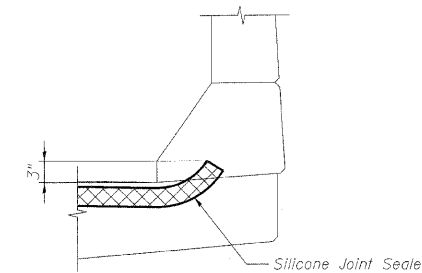

SILICONE JOINT SEALER
TREATMENT AT PARAPET

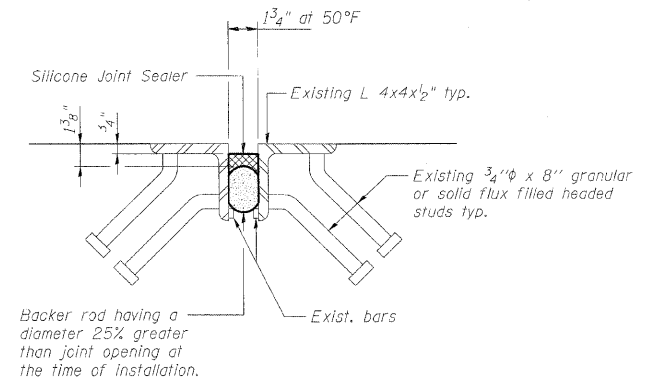

SILICONE JOINT SEALER DETAIL

BILL OF MATERIAL

Symbol	Item	Unit	Quantity
	Deck Slab Repair (Partial)	Sq. Yd.	18.6
	Structural Repair of Concrete (Depth Greater than 5 Inches)	Sq. Ft.	32
	Approach Slab Repair (Partial Depth)	Sq. Yd.	24.4
	Silicone Joint Sealer	Foot	228.0

Notes:

- Deck and approach slab repair areas are estimated based on visual inspection completed in June 2009. Actual repair areas and locations shall be determined by the Engineer and shown on As-Built plans.
- Deck drains (downspouts, floor drains and scuppers) shall be cleaned with the bridge deck prior to application of the Concrete Sealer. Cost of cleaning the deck drains is included with Concrete Sealer.
- Cost of Removal of existing preformed joint seal is included with Silicone Joint Sealer.

BRIDGE DECK AND APPROACH SLAB REPAIRS
STRUCTURE NO. 016-0088

benesch

alfred benesch & company
Engineers - Surveyors - Planners
205 North Michigan Avenue, Suite 2400
Chicago, Illinois 60601
312-565-0450 Job No. 10050

SHEET NO. 4 4 SHEETS	F.A.I. RTE.	SECTION	COUNTY	TOTAL SHEETS	SHEET NO.
	290	(3031.1, ETC., 3838)RS-5	COOK	298	245
FED. ROAD DIST. NO.			ILLINOIS	FED. AID PROJECT	
CONTRACT NO. 60G52					

STATE OF ILLINOIS
DEPARTMENT OF TRANSPORTATION

Existing Structure:
Existing Bridge No. 016-0090 at Sta. 22+27.21 F.A.I. Rte. 290 was built in 1958 as F.A. Rte. I-Project I-01-4(11), Section 062-3434.1-150. It is a two span continuous composite wide flange beam bridge, 199'-7" bk. to bk. closed abutments cantilever type and solid pier on spread footing. The Bridge was widened in 1984 to 104'-0" O. to O.

Stage construction shall be utilized to maintain traffic during construction.

No salvage.

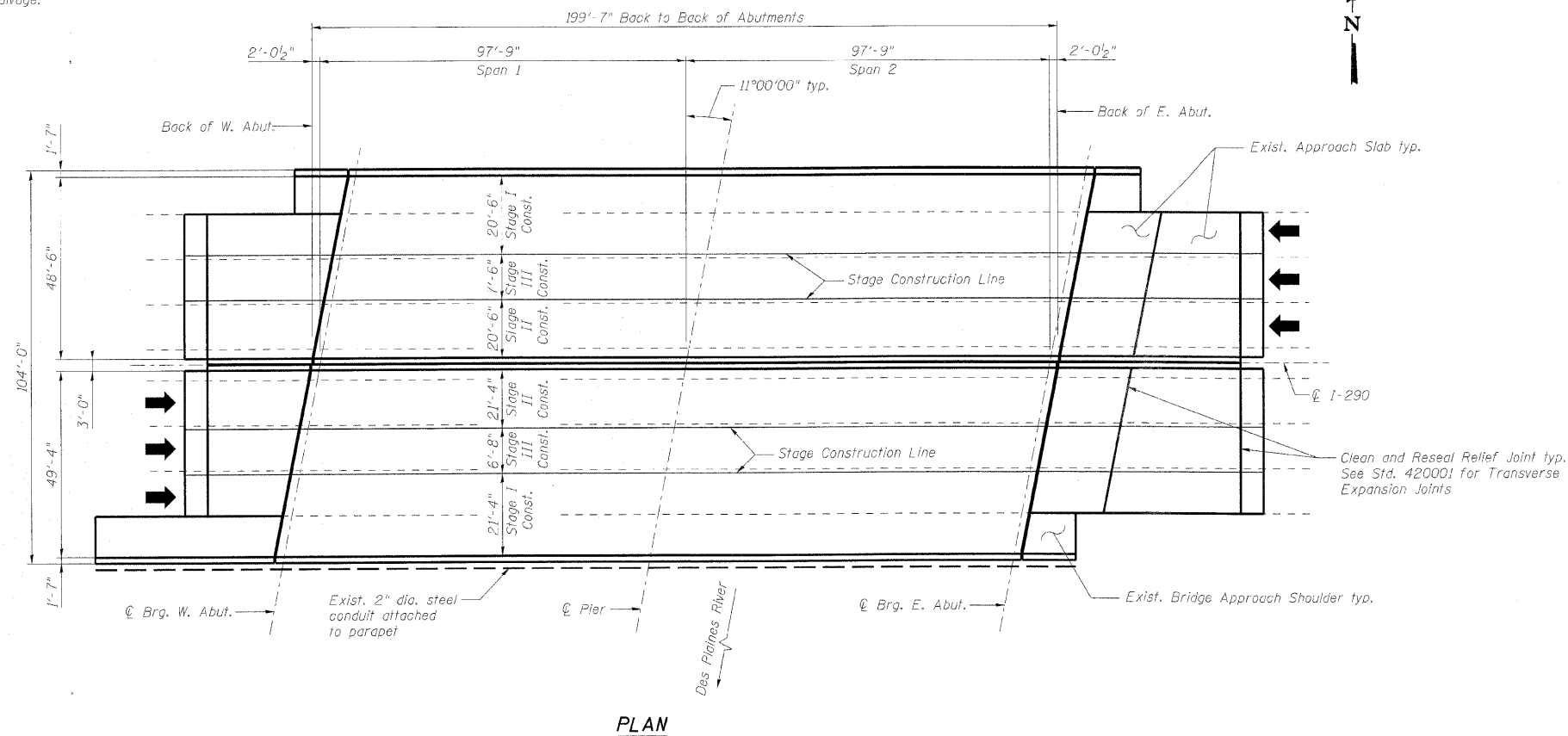

PLAN

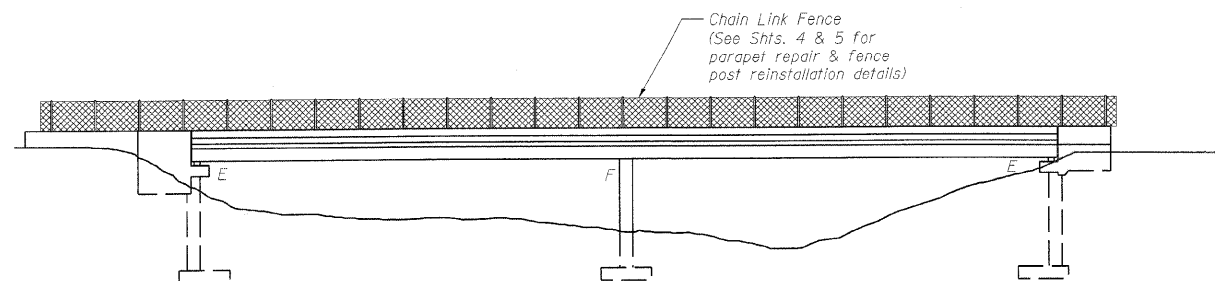

ELEVATION

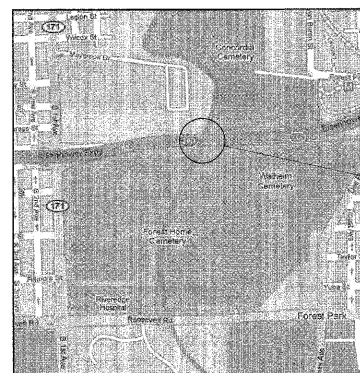

LOCATION SKETCH

DESIGN SPECIFICATIONS

2002 AASHTO Standard Specifications for Highway Bridges, 17th Edition

DESIGN STRESSES

$f'_c = 3,500$ psi
 $f_y = 60,000$ psi

SCOPE OF WORK

1. Repair bridge decks.
2. Repair approach slabs.
3. Remove and reinstall chain link fence posts and base plates, including concrete repair along eastbound outside parapet.
4. Clean and reseal relief joints at end of approach slabs.
5. Replace preformed joint seals with silicone joint seals.
6. Apply concrete sealer to bridge decks, parapets, approach slabs, abutment seats and backwalls.



EXPIRATION DATE 11-30-10
DATE 11/16/09

GENERAL PLAN AND ELEVATION
I-290 OVER DES PLAINES RIVER
COOK COUNTY
STATION 721+68
STRUCTURE NO. 016-0090

DESIGNED	-	DMS
CHECKED	-	EFS
DRAWN	-	RMG
CHECKED	-	KJN

benesch

alfred benesch & company
Engineers • Surveyors • Planners
205 North Michigan Avenue, Suite 2400
Chicago, Illinois 60601
312-565-0450 Job No. 10050

SHEET NO. 1 5 SHEETS	F.A.I. RTE.	SECTION	COUNTY	TOTAL SHEETS	SHEET NO.
	290	(3031.1, ETC., 3838)RS-5	COOK	298	246
FED. ROAD DIST. NO.			ILLINOIS	FED. AID PROJECT	
				CONTRACT NO. 60G52	

STATE OF ILLINOIS
DEPARTMENT OF TRANSPORTATION

GENERAL NOTES

Reinforcement bars shall conform to the requirements of ASTM A 706 Gr 60. See Special Provisions.

Plan dimensions and details relative to existing plans are subject to nominal construction variations. The Contractor shall field verify existing dimensions and details affecting new construction and make necessary approved adjustments prior to construction or ordering of materials. Such variations shall not be cause for additional compensation for a change in scope of the work, however, the Contractor will be paid for the quantity actually furnished at the unit price bid for the work.

Concrete Sealer shall be applied to the bridge decks, top and inside faces of parapets, approach slabs, abutment seats and abutment backwalls. All surfaces to be sealed shall be cleaned thoroughly prior to sealer application. Cost included in Concrete Sealer.

Stage construction shall be utilized to maintain traffic during construction.

INDEX OF SHEETS

1. General Plan and Elevation
2. General Notes, Bill of Material and Index of Sheets
3. Stage Construction Details
4. Bridge Deck and Approach Slab Repairs
5. Chain Link Fence Post and Bridge Parapet Repairs

TOTAL BILL OF MATERIAL

ITEM	UNIT	SUPER	SUB	TOTAL
Concrete Sealer	Sq. Ft.	28,100	1,327	29,427
Silicone Joint Sealer	Foot	199.5		199.5
Approach Slab Repair (Partial Depth)	Sq. Yd.	49.0		49.0
Deck Slab Repair (Partial)	Sq. Yd.	10.0		10.0
Clean & Reseal Relief Joint	Foot	217.5		217.5
Remove and Reinstall Chain Link Fence Post	Each	7		7

**GENERAL NOTES, BILL OF MATERIAL
AND INDEX OF SHEETS
STRUCTURE NO. 016-0090**

DESIGNED -	DMS
CHECKED -	EFS
DRAWN -	RMG
CHECKED -	KJN

benesch

alfred benesch & company
Engineers • Surveyors • Planners
205 North Michigan Avenue, Suite 2400
Chicago, Illinois 60601
312-565-0450 Job No. 10050

SHEET NO. 2 5 SHEETS	F.A.I. RTE.	SECTION	COUNTY	TOTAL SHEETS	SHEET NO.
	290	(3031.1, ETC., 3838)RS-5	COOK	298	247
FED. ROAD DIST. NO.			ILLINOIS	CONTRACT NO. 60G52	
FED. ROAD DIST. NO.			ILLINOIS	FED. AID PROJECT	

STATE OF ILLINOIS
DEPARTMENT OF TRANSPORTATION

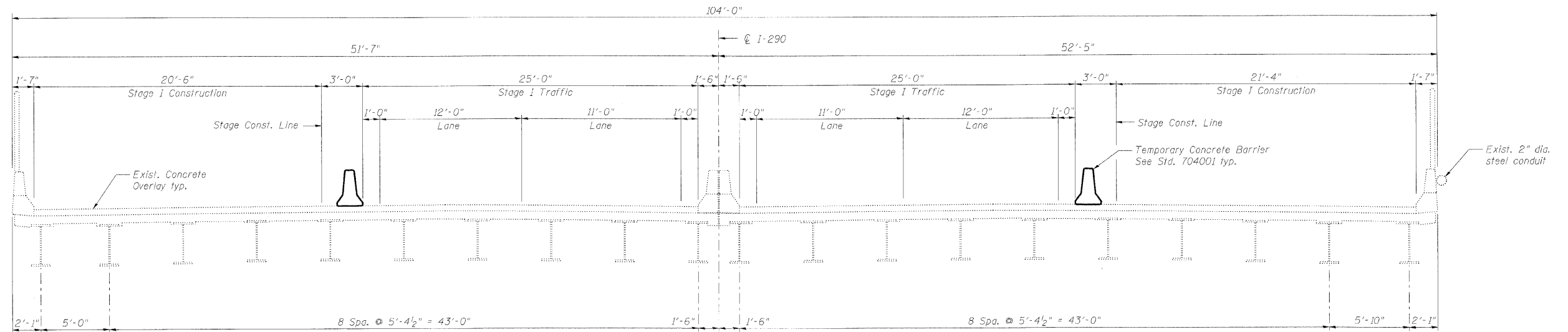

STAGE I CROSS SECTION
(Looking East)

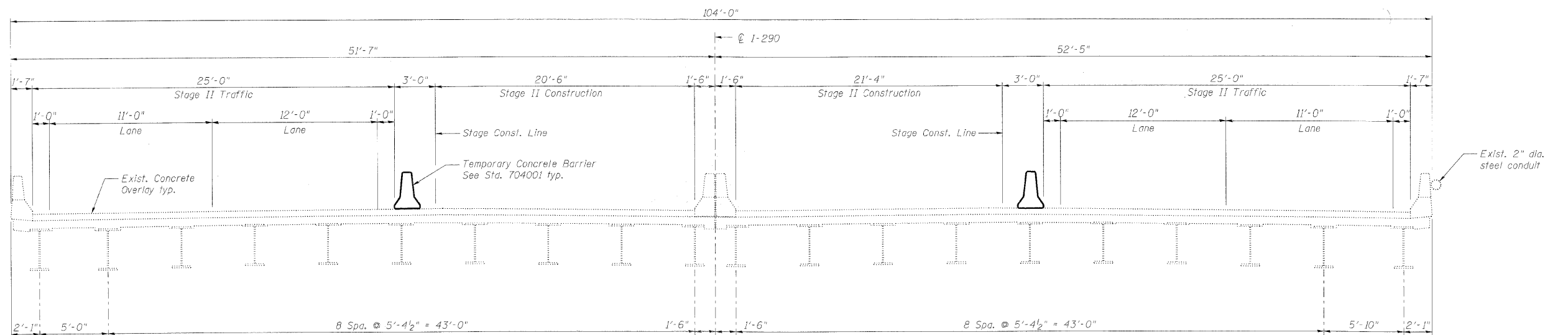

STAGE II CROSS SECTION
(Looking East)

Note:
For quantity of Temporary Concrete Barrier, see roadway plans.

Stage III Note:

Bridge deck and approach slab repairs between Stage I and Stage II construction lines shall be performed over a weekend using IDOT District 1 Std. TC-25 Center Lane Closure. See Maintenance of Traffic Plans. Concrete for Stage III patching shall be Class PP-2.

STAGE CONSTRUCTION DETAILS
STRUCTURE NO. 016-0090

DESIGNED	MFB
CHECKED	MAC
DRAWN	VH
CHECKED	KJN

benesch

alfred benesch & company
Engineers • Surveyors • Planners
205 North Michigan Avenue, Suite 2400
Chicago, Illinois 60601
312-565-0450 Job No. 10050

SHEET NO. 3 5 SHEETS	F.A.I. RTE.	SECTION	COUNTY	TOTAL SHEETS	SHEET NO.
	290	(3031.1, ETC., 3838)RS-5	COOK	298	248
FED. ROAD DIST. NO.			ILLINOIS	FED. AID PROJECT	
CONTRACT NO. 60G52					

STATE OF ILLINOIS
DEPARTMENT OF TRANSPORTATION

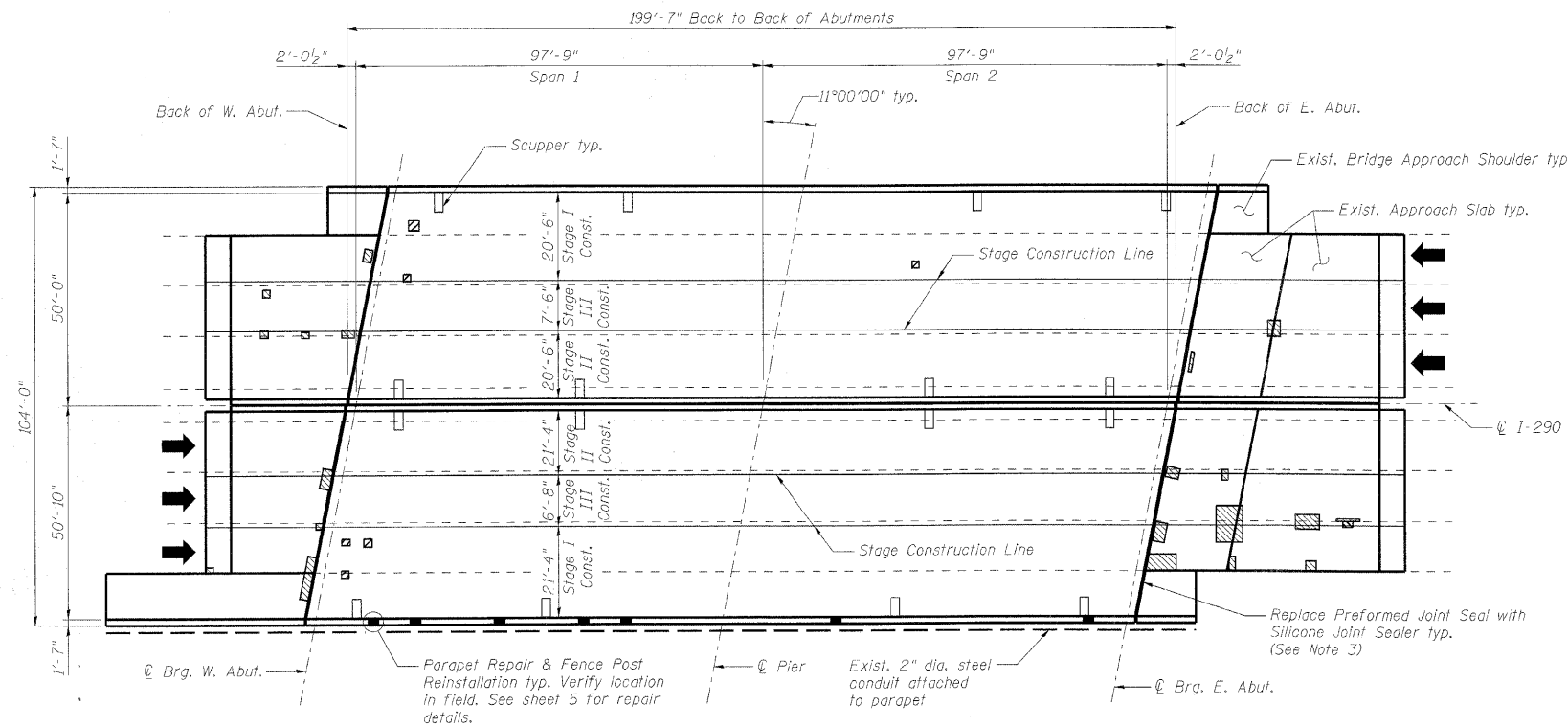

Stage III Note:

Bridge deck and approach slab repairs between Stage I and Stage II construction lines shall be performed over a weekend using IDOT District 1 Std. TC-25 Center Lane Closure. See Maintenance of Traffic Plans. Concrete for Stage III patching shall be Class PP-2.

BILL OF MATERIAL

Symbol	Item	Unit	Quantity
	Deck Slab Repair (Partial)	Sq. Yd.	10.0
	Approach Slab Repair (Partial Depth)	Sq. Yd.	49.0
	Silicone Joint Sealer	Foot	199.5

PLAN

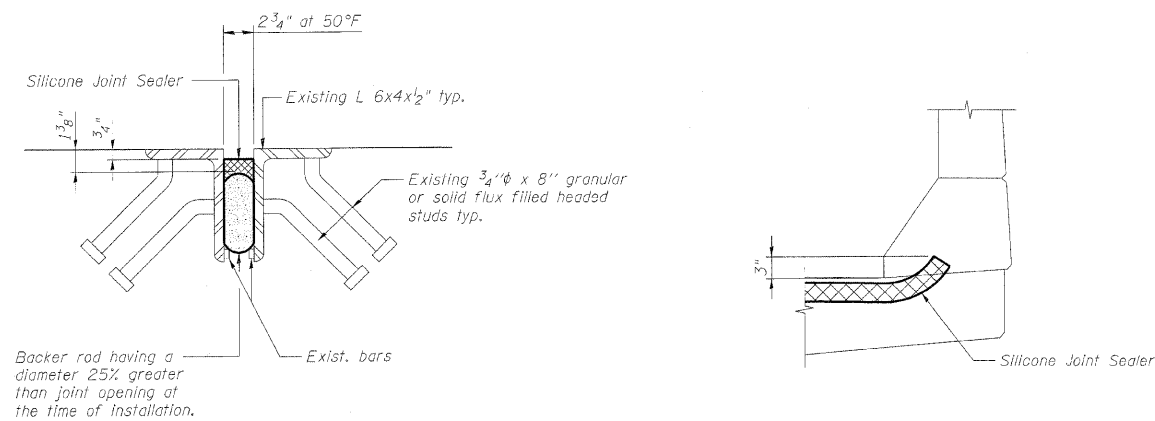

SILICONE JOINT SEALER DETAIL

SILICONE JOINT SEALER TREATMENT AT PARAPET

Notes:

- Deck and approach slab repair areas are estimated based on visual inspection completed in June 2009. Actual repair areas and locations shall be determined by the Engineer and shown on As-Built plans.
- Deck drains (downspouts, floor drains and scuppers) shall be cleaned with the bridge deck prior to application of the Concrete Sealer. Cost of cleaning the deck drains is included with Concrete Sealer.
- The construction joint between the approach slab and backwall closure pour, adjacent to the existing preformed joint seal, shall be cleaned and sealed with hot-poured joint sealer according to Section 452 of the Std. Specifications. Cost included with "Concrete Sealer".
- Cost of Removal of existing preformed joint seal is included with Silicone Joint Sealer.

DESIGNED	DMS
CHECKED	EFS
DRAWN	RMG
CHECKED	KJN

benesch

alfred benesch & company
Engineers • Surveyors • Planners
205 North Michigan Avenue, Suite 2400
Chicago, Illinois 60601
312-565-0450 Job No. 10050

SHEET NO. 4 5 SHEETS	F.A.I. RTE.	SECTION	COUNTY	TOTAL SHEETS	SHEET NO.
	290	(3031.1, ETC., 3838)RS-5	COOK	298	249
FED. ROAD DIST. NO.			ILLINOIS FED. AID PROJECT		
CONTRACT NO. 60G52					

**BRIDGE DECK AND APPROACH SLAB REPAIRS
STRUCTURE NO. 016-0090**

x:\10000s\10050\Engineering\Documents\Contract_2\SN_016_0090_Des.Plaines_River\0090-60G52-004-deckrepair.dgn

17:51:11

11/12/2009

STATE OF ILLINOIS
DEPARTMENT OF TRANSPORTATION

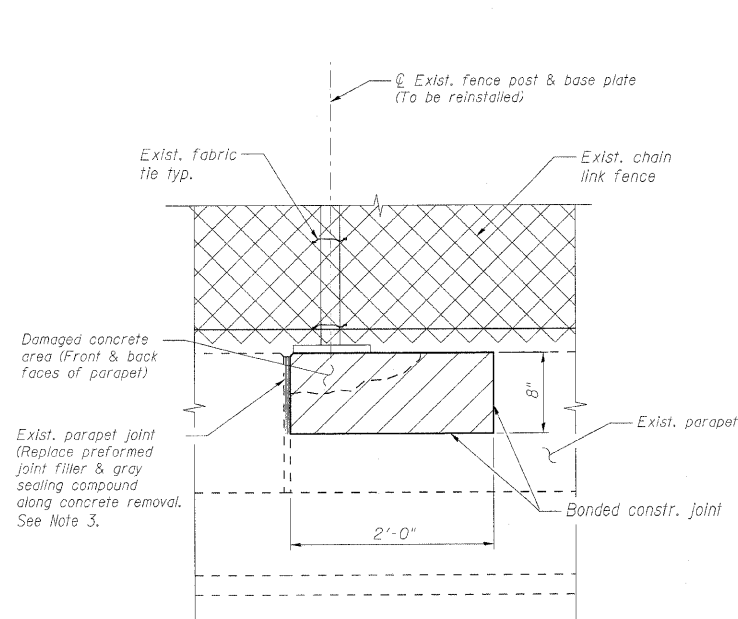

INSIDE ELEVATION - REPAIR AT PARAPET JOINT
(2 Locations)

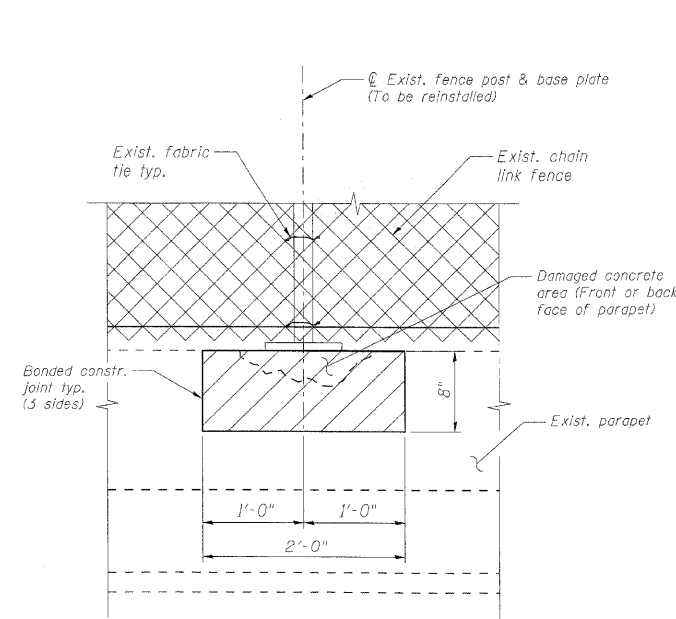

INSIDE ELEVATION - REPAIR AWAY FROM PARAPET JOINT
(5 Locations)

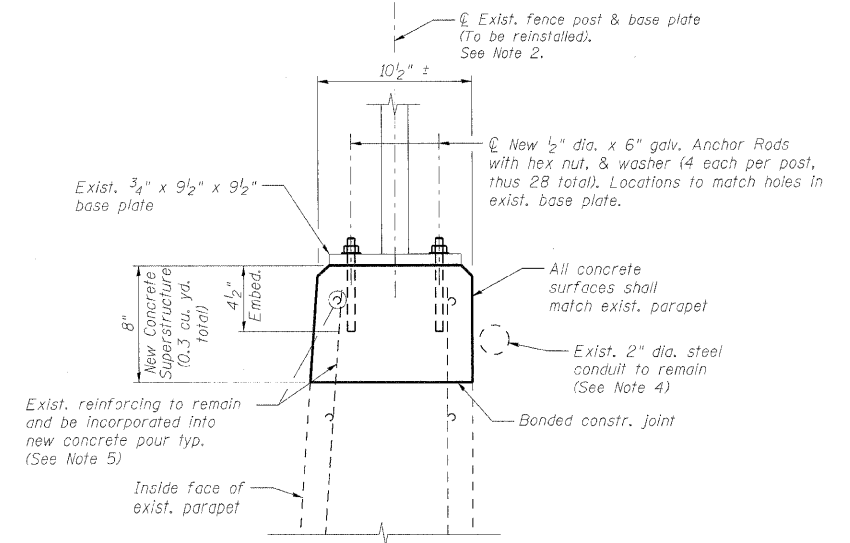

TYPICAL SECTION AT PARAPET REPAIR

Notes:

1. Work this sheet with sheets 1 and 4.
2. The existing fence post and base plate have twisted, causing localized damage to the existing concrete parapet and several anchor rods. The existing fence post and base plate shall be removed and reinstalled with the new concrete parapet repair. The fence post and base plate shall be realigned and centered across the parapet to match the existing non-damaged fence posts and base plates. The new anchor rods shall be cast-in-place. Drilling and setting of the anchor rods is prohibited.
3. The existing parapet joint shall be replaced using a 1/2" Preformed Self-Expanding Cork Joint Filler according to Article 1051.07 of the Std. Spec., and non-staining gray one component non-sag elastomeric gun grade polyurethane sealant meeting the requirements of ASTM C-290, Type S, Grade NS, Class 25, Use T, to match the existing joint installation.
4. The Contractor shall exercise extreme care with the existing steel conduit attached to the back face of the parapet to be removed, and to protect and support the conduit. The Contractor will be required to repair any damage done to the conduit to the satisfaction of the Engineer. No splicing will be allowed to any cable damage resulting from this work. Instead the Contractor will be required to repair the entire span of any damaged cable at no additional cost to the Department.
5. Existing reinforcement bars extending into the concrete removal area shall be cleaned, straightened and incorporated into the new construction. Any reinforcement bars that are damaged during concrete removal shall be repaired or replaced with an approved bar splicer or anchorage system. Cost included with "Remove and Reinstall Chain Link Fence Post".
6. The Contractor shall ensure that all concrete parapet to be removed is contained and not allowed to fall into the Des Plaines River. If Protective Shield is necessary, then the cost shall be included in "Remove and Reinstall Chain Link Fence Post".
7. The cost of concrete removal, concrete superstructure, preformed joint filler, gray sealing compound, chain link fence fabric ties, threaded anchor rods, nuts and washers is included with "Remove and Reinstall Chain Link Fence Post". See Special Provision.

 Limits of Concrete Removal & Replacement (See Note 6)

BILL OF MATERIAL

ITEM	UNIT	QUANTITY
Remove and Reinstall Chain Link Fence Post	Each	7

**CHAIN LINK FENCE POST
AND BRIDGE PARAPET REPAIRS
STRUCTURE NO. 016-0090**

DESIGNED	-	KJN
CHECKED	-	KWS
DRAWN	-	RMG
CHECKED	-	KJN

benesch

alfred benesch & company
Engineers • Surveyors • Planners
205 North Michigan Avenue, Suite 2400
Chicago, Illinois 60601
312-565-0450 Job No. 10050

SHEET NO. 5	F.A.I. RTE.	SECTION	COUNTY	TOTAL SHEETS	SHEET NO.
5 SHEETS					
FED. ROAD DIST. NO.			ILLINOIS FED. AID PROJECT		



DES PLAINES RIVER

FAI I-290 WB

FAI I-290 EB

TYP. EX SENSOR AND LEAD-IN CABLE TO BE REPLACED

EX. SENSOR

EX. CONDUIT ON GURADRAIL BEHIND BARRELS

ISLAND

PUMP STATION

NOTE:
 IDOT RECORD PLAN PROVIDED FOR INFORMATION ONLY. THE CONTRACTOR IS RESPONSIBLE FOR VERIFYING THE LOCATION AND EXTENT OF WORK ASSOCIATED WITH REPLACEMENT OF SURFACE SENSORS AND SUBSURFACE PROBE, LEAD-IN CABLES AND RELATED WORK.

LEGEND

□ EX. SURFACE SENSOR

⊗ RPU

ROADWAY WEATHER INFORMATION SYSTEM (RWIS)

I-290 OVER DES PLAINES RIVER

SCALE: 1 INCH = 20 FEET FOREST PARK, IL

FILE NAME -	DESIGNED - GHT	REVISED -
...\\Signal\app\In_ABC_C2_HIDS.dgn	DRAWN - TMB	REVISED -
USER NAME - majewski	CHECKED - MPV	REVISED -
PLOT DATE - 11/13/2009	DATE - 10/16/09	REVISED -

benesch

**STATE OF ILLINOIS
DEPARTMENT OF TRANSPORTATION**

ROADWAY WEATHER INFORMATION SYSTEM SENSOR			
SCALE: N.T.S.	SHEET NO. 2 OF 1 SHEETS	STA.	TO STA.

F.A.I. RTE.	SECTION	COUNTY	TOTAL SHEETS	SHEET NO.
290	(3031.1, ETC., 3838)RS-5	COOK	298	251
FED. ROAD DIST. NO.			ILLINOIS FED. AID PROJECT	
			CONTRACT NO. 60652	

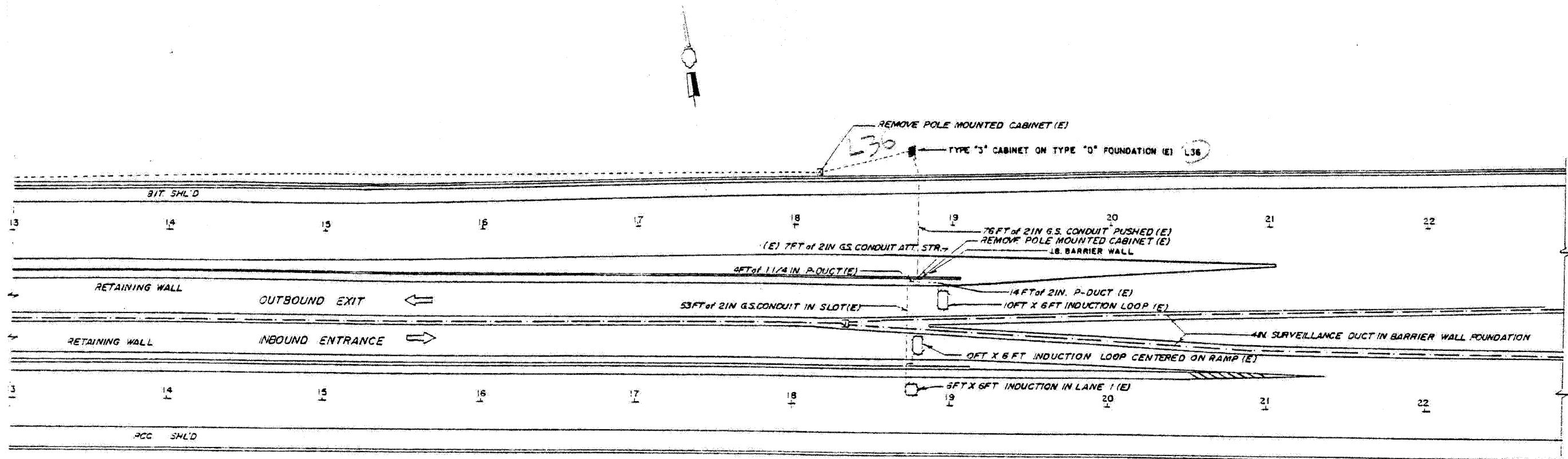

- INDUCTION LOOP
- POLYETHYLENE DUCT
- G.S. CONDUIT
- PULL POINT
- HANDHOLE
- HEAVY DUTY HAND HOLE
- T.S. CABINET
- SERVICE INSTALLATION
- (E) EXISTING FACILITIES
- (R) REMOVE EXISTING FACILITIES

NOTE:

IDOT RECORD PLANS PROVIDED FOR INFORMATIONAL PURPOSES ONLY. THE CONTRACTOR IS RESPONSIBLE FOR VERIFYING THE LOCATION AND EXTENT OF WORK ASSOCIATED WITH REPLACEMENT OF INDUCTION LOOPS, LEAD-IN CABLE AND RELATED WORK.

SUMMARY OF QUANTITIES (THIS SHEET)		
DESCRIPTION	UNIT	QUANTITY
ELECTRIC CABLE IN CONDUIT, LEAD-IN, NO. 18 4/C, TWISTED, SHIELDED	LF	377
INDUCTION LOOP	LF	104

FILE NAME =	DESIGNED - GHT	REVISED -
...signals\prpIn_ABC_C2_ts_02.dgn	DRAWN - TMB	REVISED -
USER NAME = tblank	CHECKED - MPM	REVISED -
PLOT DATE = 11/12/2009	DATE - 10/16/09	REVISED -

benesch

**STATE OF ILLINOIS
DEPARTMENT OF TRANSPORTATION**

**TRAFFIC SURVEILLANCE
AUSTIN AVE INSTALLATION (2 OF 2)**

SCALE: N.T.S. SHEET NO. 2 OF 16 SHEETS STA. TO STA.

F.A.I. RTE.	SECTION	COUNTY	TOTAL SHEETS	SHEET NO.
290	(3031.1, ETC., 3838)RS-5	COOK	298	253
FED. ROAD DIST. NO. ILLINOIS FED. AID PROJECT			CONTRACT NO. 60652	

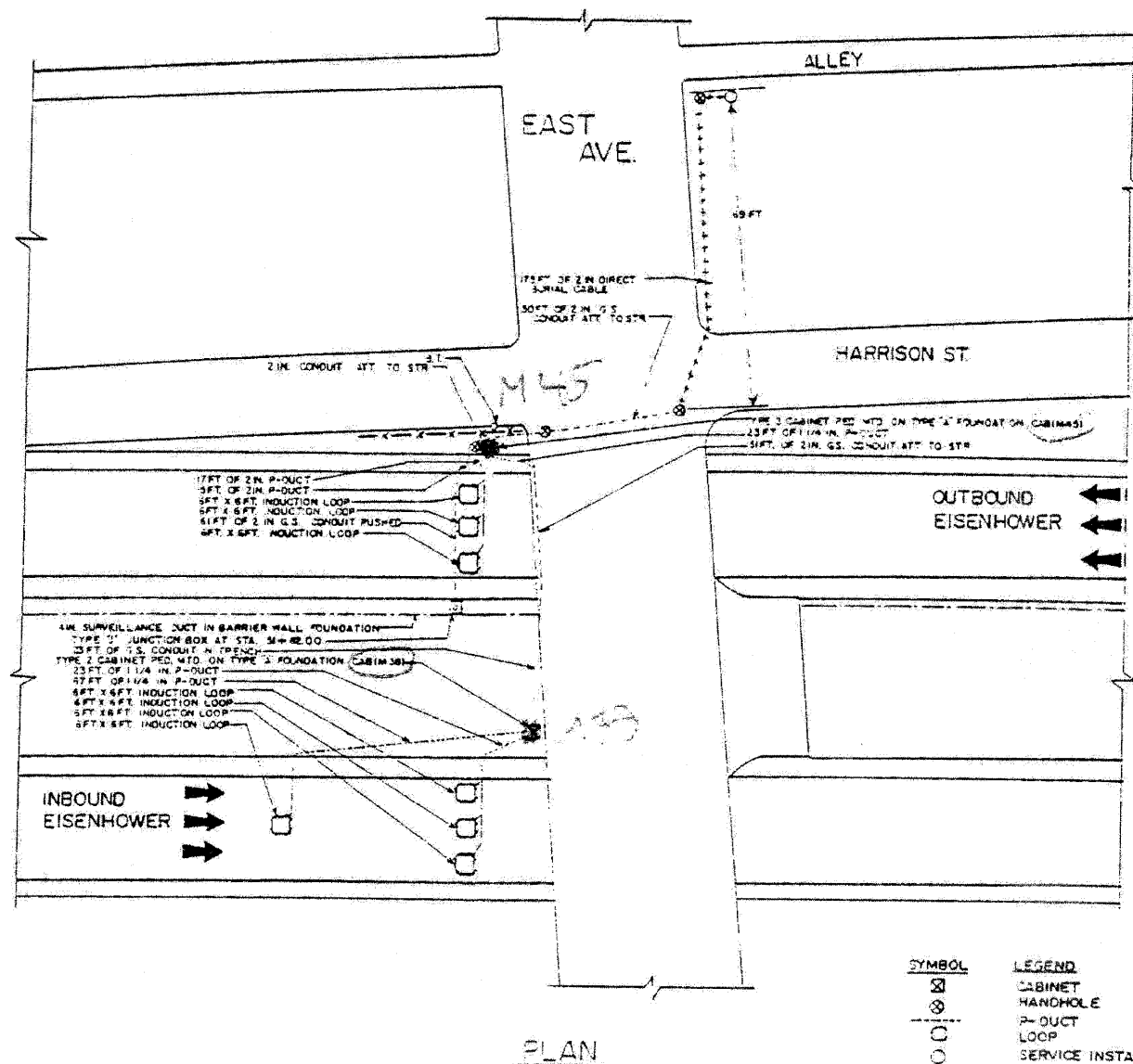

SYMBOL	LEGEND
⊗	CABINET
⊙	HANDHOLE
—○—	P-DUCT
○	LOOP
○	SERVICE INSTALLATION
—○—	G.S. CONDUIT
⊕	JUNCTION BOX
+++++	DIRECT BURIAL CABLE
-X-X-X-	FENCE

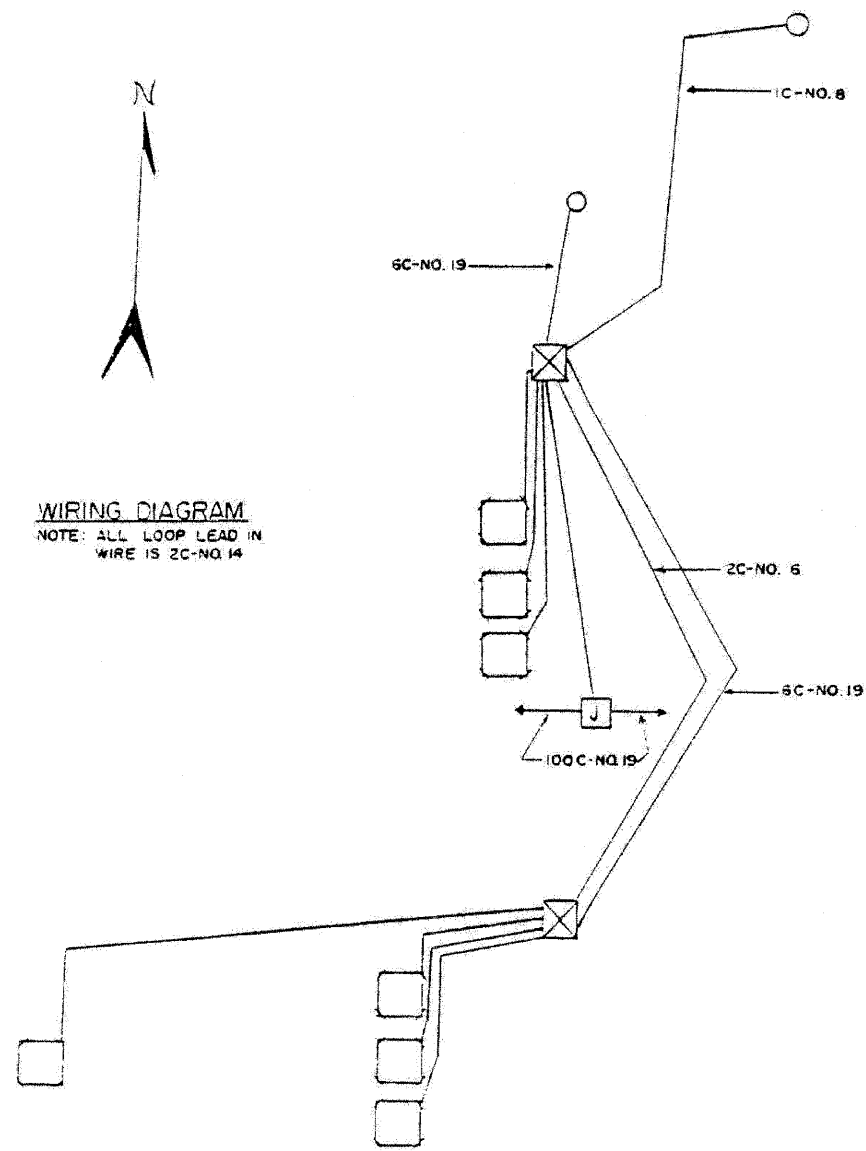

NOTE:
IDOT RECORD PLANS PROVIDED FOR INFORMATIONAL PURPOSES ONLY. THE CONTRACTOR IS RESPONSIBLE FOR VERIFYING THE LOCATION AND EXTENT OF WORK ASSOCIATED WITH REPLACEMENT OF INDUCTION LOOPS, LEAD-IN CABLE AND RELATED WORK.

SUMMARY OF QUANTITIES (THIS SHEET)		
DESCRIPTION	UNIT	QUANTITY
ELECTRIC CABLE IN CONDUIT, LEAD-IN, NO. 18 4/C, TWISTED, SHIELDED	LF	214
INDUCTION LOOP	LF	266

FILE NAME =	DESIGNED - GHT	REVISED -
...:\signals\prpIn_ABC.C2_ts_03.dgn	DRAWN - TMB	REVISED -
USER NAME = tblank	CHECKED - MPM	REVISED -
PLOT DATE = 11/12/2009	DATE - 10/16/09	REVISED -

benesch

**STATE OF ILLINOIS
DEPARTMENT OF TRANSPORTATION**

TRAFFIC SURVEILLANCE EAST AVE INSTALLATION		
SCALE: N.T.S.	SHEET NO. 3 OF 16 SHEETS	STA. TO STA.

F.A.I. RTE.	SECTION	COUNTY	TOTAL SHEETS	SHEET NO.
290	(3031.1, ETC., 3838)RS-5	COOK	298	254
FED. ROAD DIST. NO. ILLINOIS FED. AID PROJECT			CONTRACT NO. 60G52	

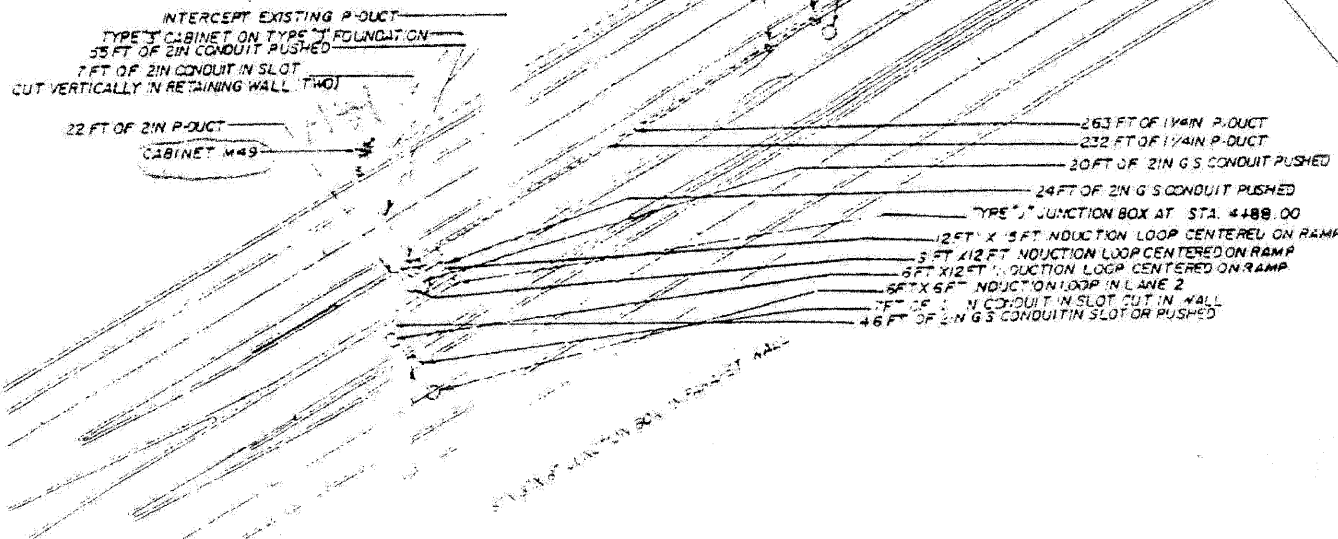
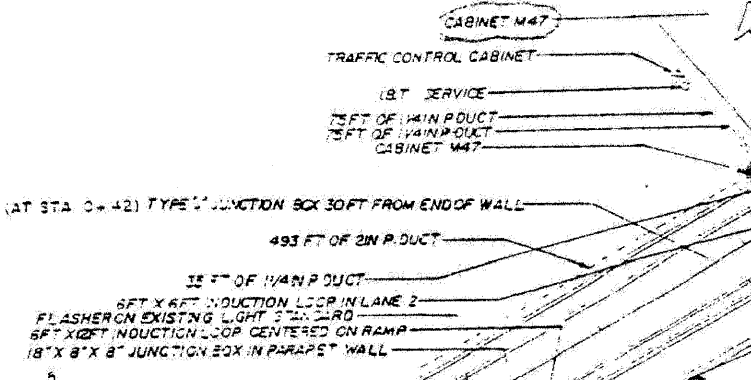
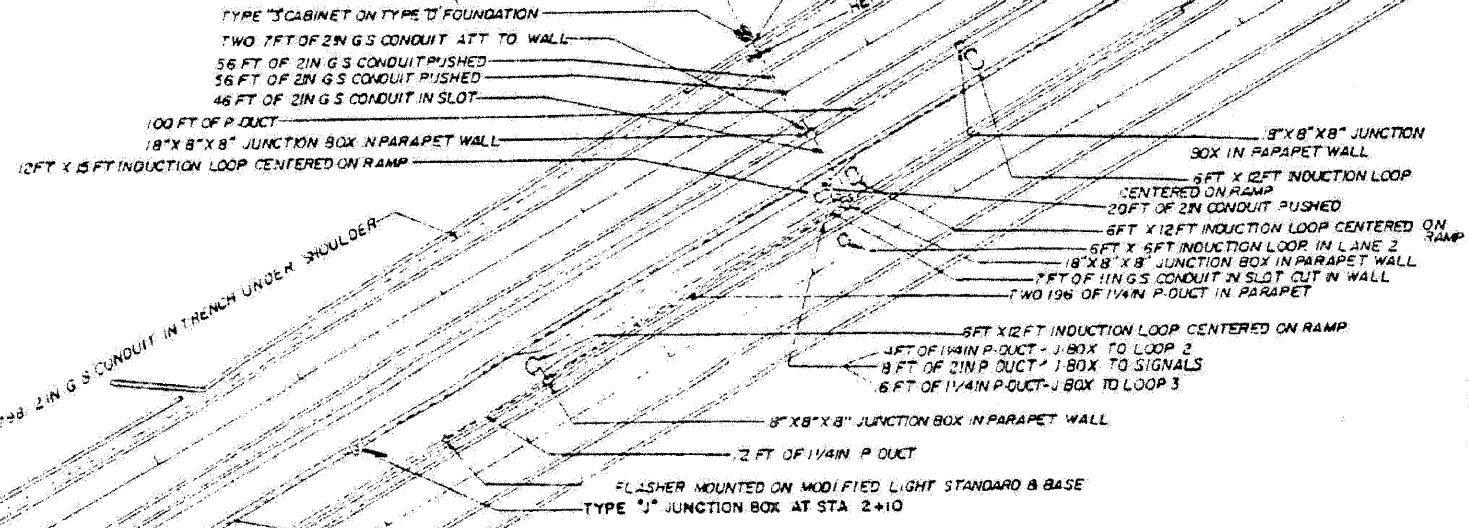
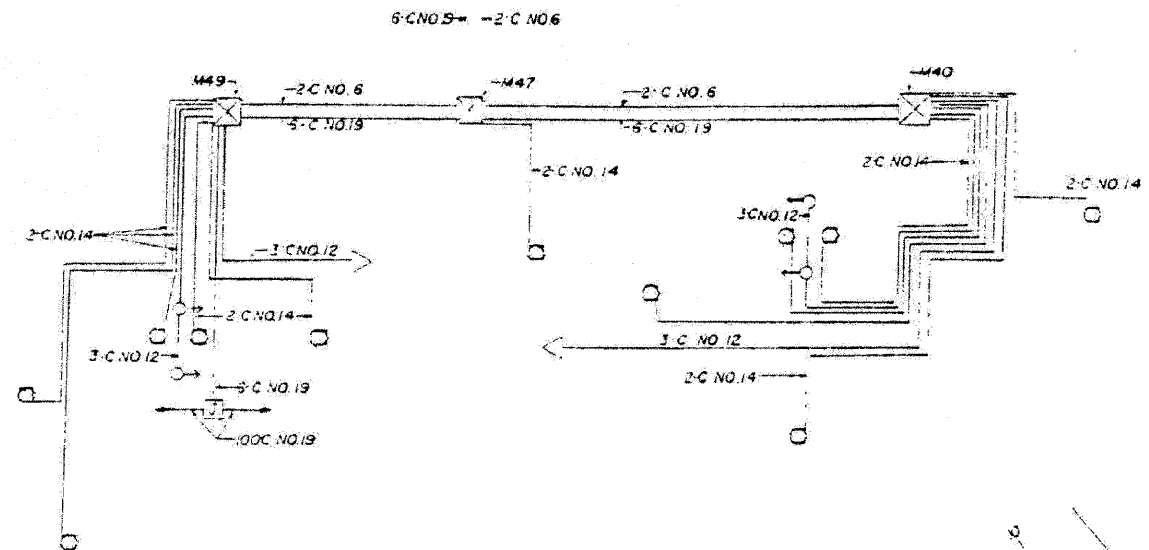

- LEGEND**
- INDUCTION LOOP
 - ⊗ T'S C CABINET
 - POLYETHYLENE DUCT
 - - - G S CONDUIT
 - HAND HOLE
 - ⊕ JUNCTION BOX TYPE "J"
 - RAMP SIGNALS
 - ◁ FLASHER
 - ⊕ HEAVY DUTY HANDHOLE

NOTE:
 IDOT RECORD PLANS PROVIDED FOR INFORMATIONAL PURPOSES ONLY. THE CONTRACTOR IS RESPONSIBLE FOR VERIFYING THE LOCATION AND EXTENT OF WORK ASSOCIATED WITH REPLACEMENT OF INDUCTION LOOPS, LEAD-IN CABLE AND RELATED WORK.

SUMMARY OF QUANTITIES (THIS SHEET)		
DESCRIPTION	UNIT	QUANTITY
ELECTRIC CABLE IN CONDUIT, LEAD-IN, NO. 18 4/C, TWISTED, SHIELDED	LF	1203
INDUCTION LOOP	LF	507

FILE NAME =	DESIGNED - GHT	REVISED -
...signals\ppr\in_abc.c2_ss_04.dgn	DRAWN - TMB	REVISED -
USER NAME = colank	CHECKED - MPM	REVISED -
PLOT DATE = 11/12/2009	DATE - 10/16/09	REVISED -

benesch

**STATE OF ILLINOIS
DEPARTMENT OF TRANSPORTATION**

**TRAFFIC SURVEILLANCE
HARLEM AVE INSTALLATION**

SCALE: N.T.S. SHEET NO. 4 OF 16 SHEETS STA. TO STA.

F.A.T. RTE.	SECTION	COUNTY	TOTAL SHEETS	SHEET NO.
290	130311, ETC., 3838RS-5	COOK	298	255
FED. ROAD DIST. NO. ILLINOIS FED. AID PROJECT			CONTRACT NO. 60652	

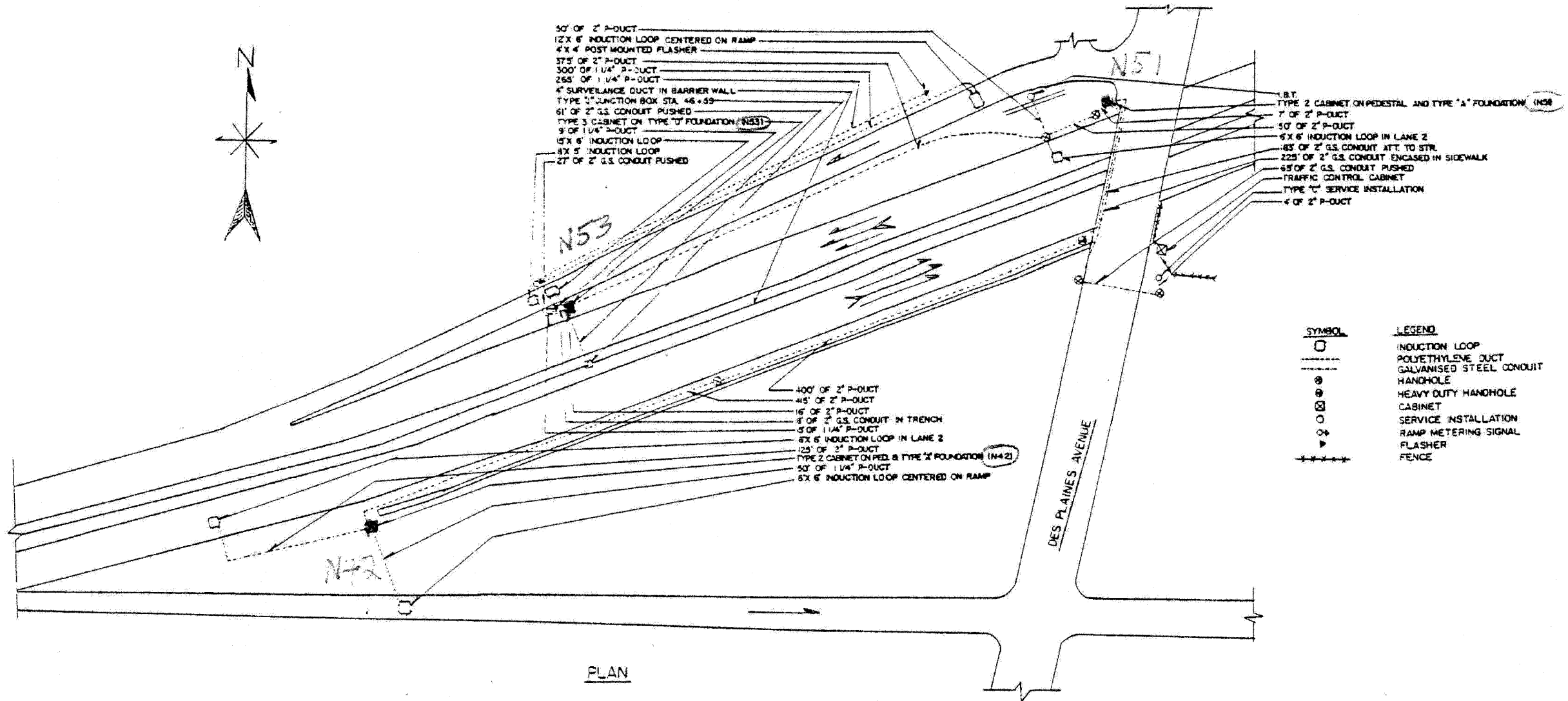

SYMBOL	LEGEND
○	INDUCTION LOOP
---	POLYETHYLENE DUCT
⊗	GALVANISED STEEL CONDUIT
⊙	HANDHOLE
⊗	HEAVY DUTY HANDHOLE
⊙	CABINET
⊙	SERVICE INSTALLATION
⊙	RAMP METERING SIGNAL
⊙	FLASHER
---	FENCE

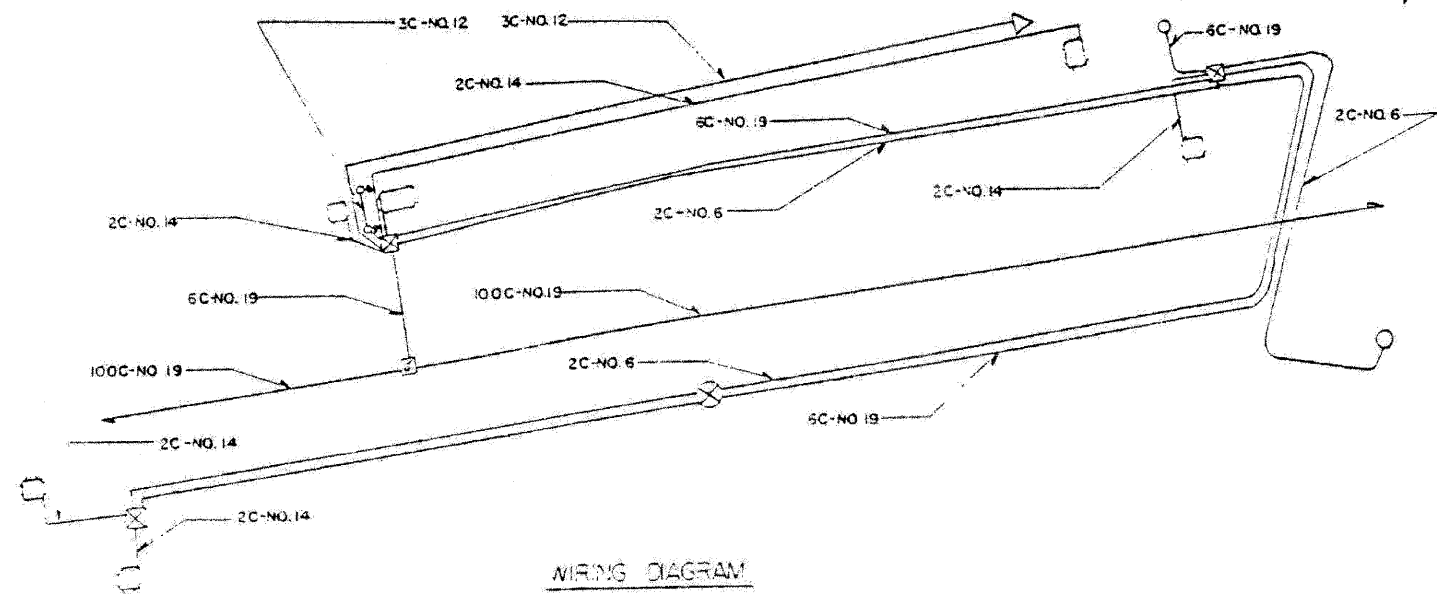

NOTE:
 IDOT RECORD PLANS PROVIDED FOR INFORMATIONAL PURPOSES ONLY. THE CONTRACTOR IS RESPONSIBLE FOR VERIFYING THE LOCATION AND EXTENT OF WORK ASSOCIATED WITH REPLACEMENT OF INDUCTION LOOPS, LEAD-IN CABLE AND RELATED WORK.

SUMMARY OF QUANTITIES (THIS SHEET)		
DESCRIPTION	UNIT	QUANTITY
ELECTRIC CABLE IN CONDUIT, LEAD-IN, NO. 18 4/C, TWISTED, SHIELDED	LF	224
INDUCTION LOOP	LF	934

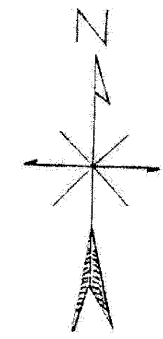
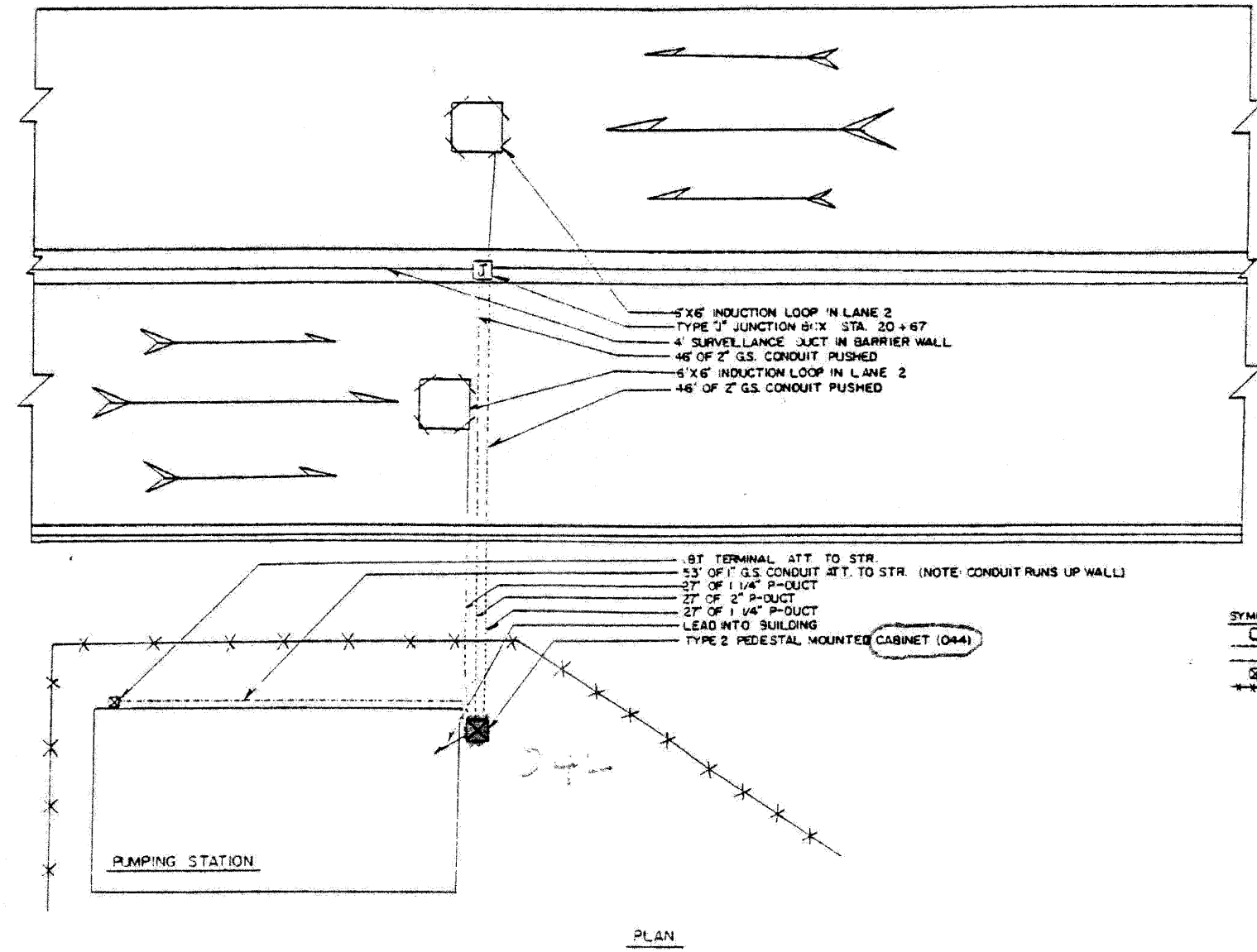
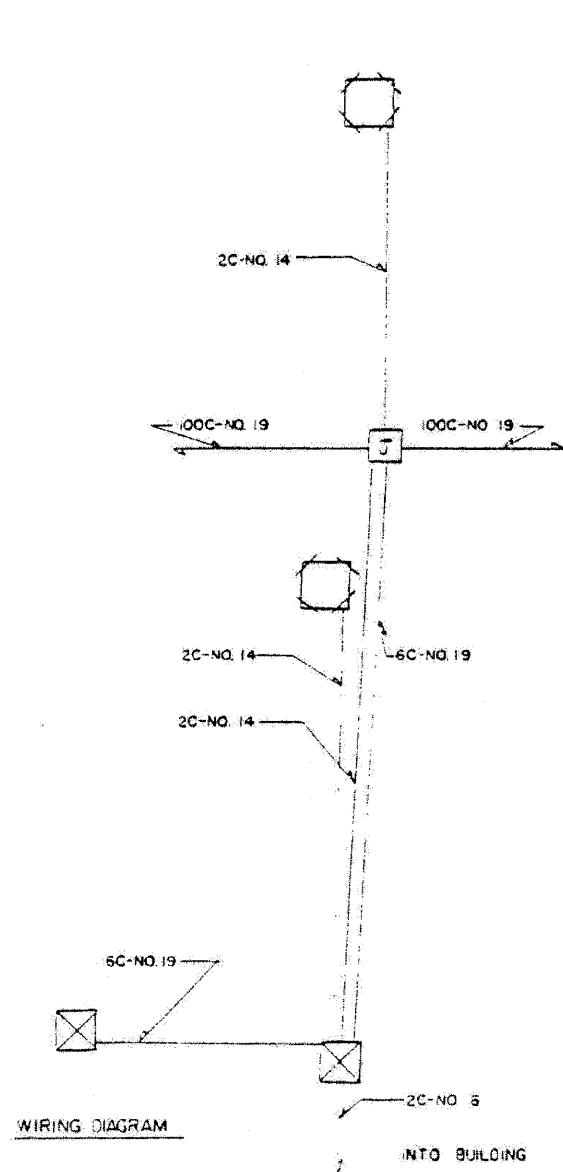

SYMBOL	LEGEND
	INDUCTION LOOP
	POLYETHYLENE DUCT
	GALVANISED STEEL CONDUIT
	CABINET
	FENCE

NOTE:
 IDOT RECORD PLANS PROVIDED FOR INFORMATIONAL PURPOSES ONLY. THE CONTRACTOR IS RESPONSIBLE FOR VERIFYING THE LOCATION AND EXTENT OF WORK ASSOCIATED WITH REPLACEMENT OF INDUCTION LOOPS, LEAD-IN CABLE AND RELATED WORK.

SUMMARY OF QUANTITIES (THIS SHEET)		
DESCRIPTION	UNIT	QUANTITY
ELECTRIC CABLE IN CONDUIT, LEAD-IN, NO. 18 4/C, TWISTED, SHIELDED	LF	122
INDUCTION LOOP	LF	76

FILE NAME =	DESIGNED - GHT	REVISED -
...signals\p\pln_abc_c2_ts_06.dgn	DRAWN - TMB	REVISED -
USER NAME = tblank	CHECKED - MPM	REVISED -
PLOT DATE = 11/12/2009	DATE - 10/16/09	REVISED -

benesch

**STATE OF ILLINOIS
 DEPARTMENT OF TRANSPORTATION**

**TRAFFIC SURVEILLANCE
 DES PLAINES RIVER INSTALLATION**

SCALE: N.T.S. SHEET NO. 6 OF 16 SHEETS STA. TO STA.

F.A.I. RTE.	SECTION	COUNTY	TOTAL SHEETS	SHEET NO.
290	(3031.1, ETC., 3838)RS-5	COOK	298	257
FED. ROAD DIST. NO. ILLINOIS FED. AID PROJECT			CONTRACT NO. 60G52	

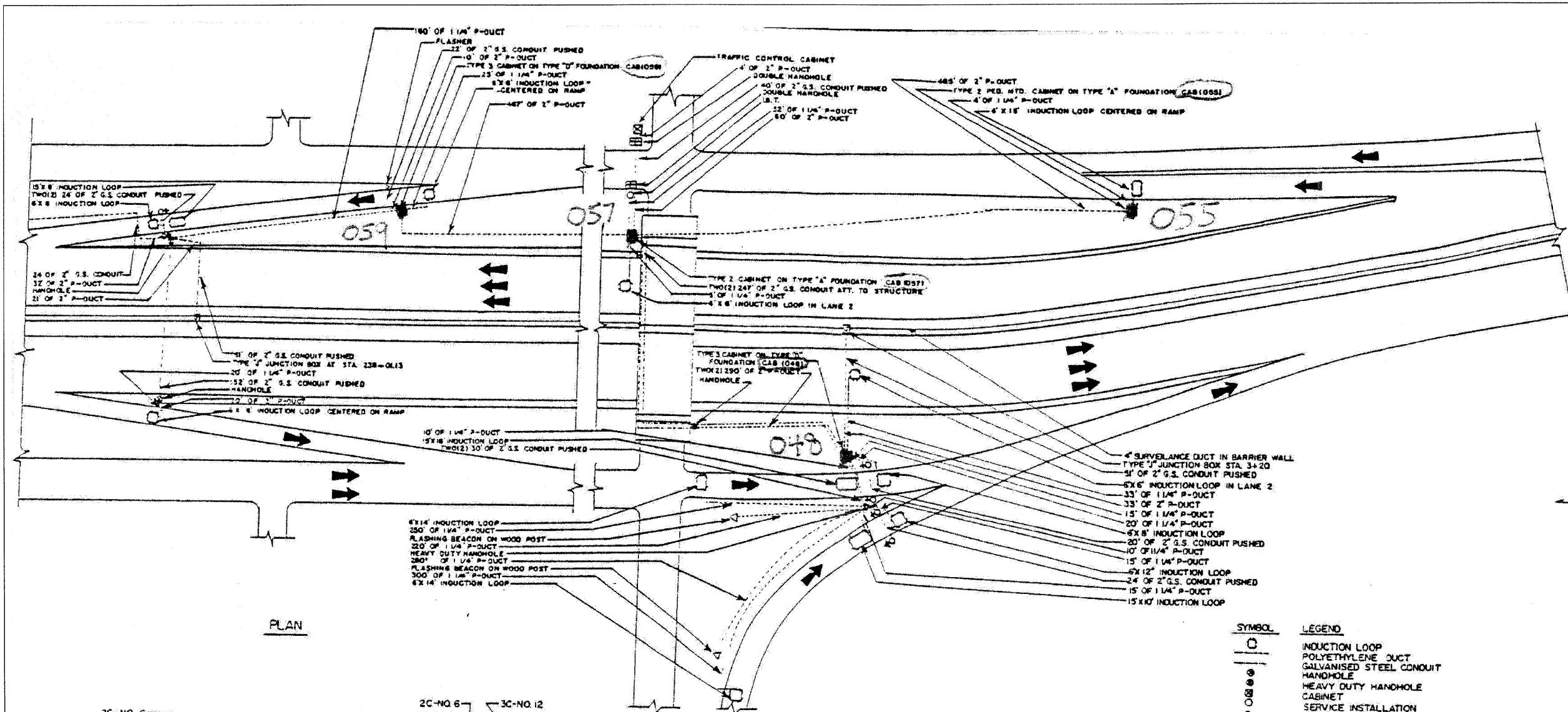

PLAN

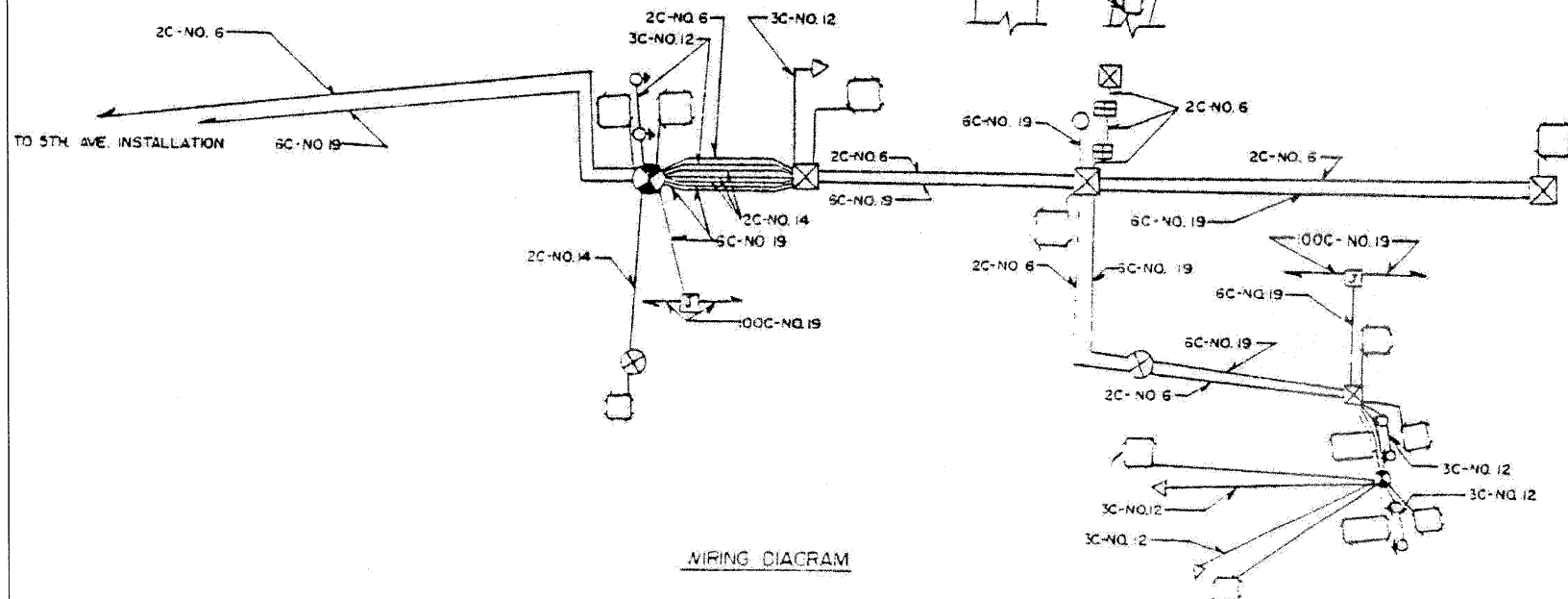

WIRING DIAGRAM

SYMBOL	LEGEND
	INDUCTION LOOP
	POLYETHYLENE DUCT
	GALVANISED STEEL CONDUIT
	HANDHOLE
	HEAVY DUTY HANDHOLE
	CABINET
	SERVICE INSTALLATION
	RAMP METERING SIGNAL
	FLASHER
	DOUBLE HANDHOLE

NOTE:
 IDOT RECORD PLANS PROVIDED FOR INFORMATIONAL PURPOSES ONLY. THE CONTRACTOR IS RESPONSIBLE FOR VERIFYING THE LOCATION AND EXTENT OF WORK ASSOCIATED WITH REPLACEMENT OF INDUCTION LOOPS, LEAD-IN CABLE AND RELATED WORK.

SUMMARY OF QUANTITIES (THIS SHEET)		
DESCRIPTION	UNIT	QUANTITY
ELECTRIC CABLE IN CONDUIT, LEAD-IN, NO. 18 4/C, TWISTED, SHIELDED	LF	1457
INDUCTION LOOP	LF	508

NOTE
 ALL LOOP LEAD IN CABLE IS 2C-NO. 14

FILE NAME =	DESIGNED - GHT	REVISED -
...signola\prp\in_ABC_C2-ts.07.dgn	DRAWN - TMB	REVISED -
USER NAME = tblank	CHECKED - MPM	REVISED -
PLOT DATE = 11/12/2009	DATE - 10/16/09	REVISED -

benesch
 STATE OF ILLINOIS
 DEPARTMENT OF TRANSPORTATION

**TRAFFIC SURVEILLANCE
 FIRST AVE INSTALLATION**
 SCALE: N.T.S. SHEET NO. 7 OF 16 SHEETS STA. TO STA.

F.A.I. RTE.	SECTION	COUNTY	TOTAL SHEETS	SHEET NO.
290	(3031.1, ETC., 3838)RS-5	COOK	298	258
CONTRACT NO. 60052				
FED. ROAD DIST. NO. ILLINOIS FED. AID PROJECT				

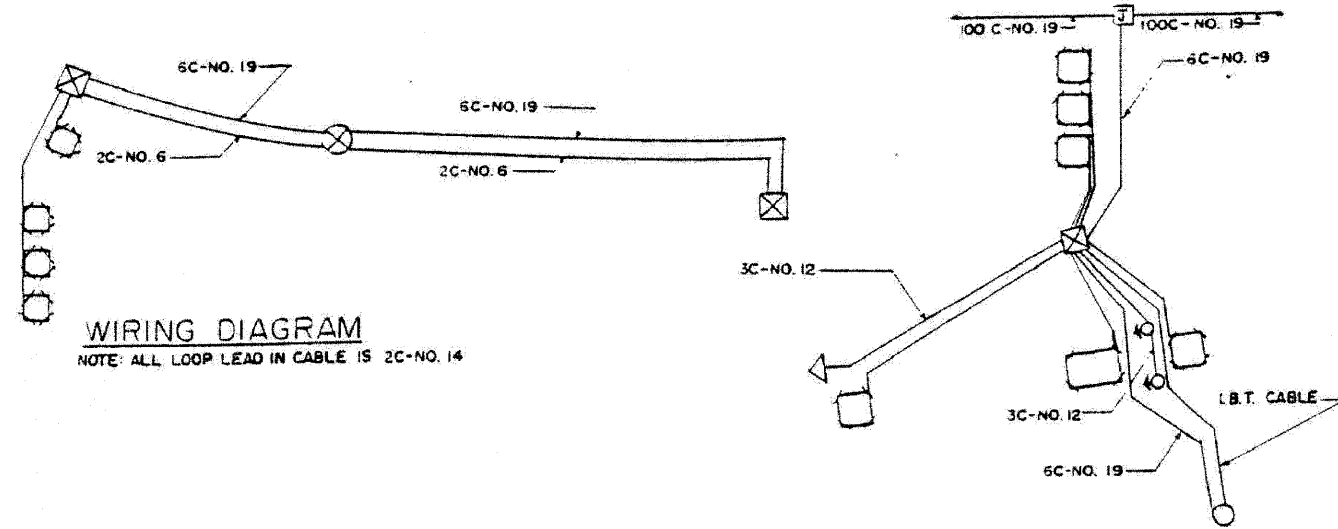
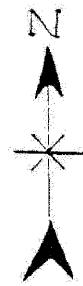

SYMBOL	LEGEND
○	INDUCTION LOOP
—	POLYETHYLENE DUCT
---	G.S. CONDUIT
⊗	HANDHOLE
⊕	HEAVY DUTY HANDHOLE
⊙	CABINET
○	SERVICE INSTALLATION
△	RAMP SIGNAL
—X—X—	FLASHER
—X—X—	FENCE

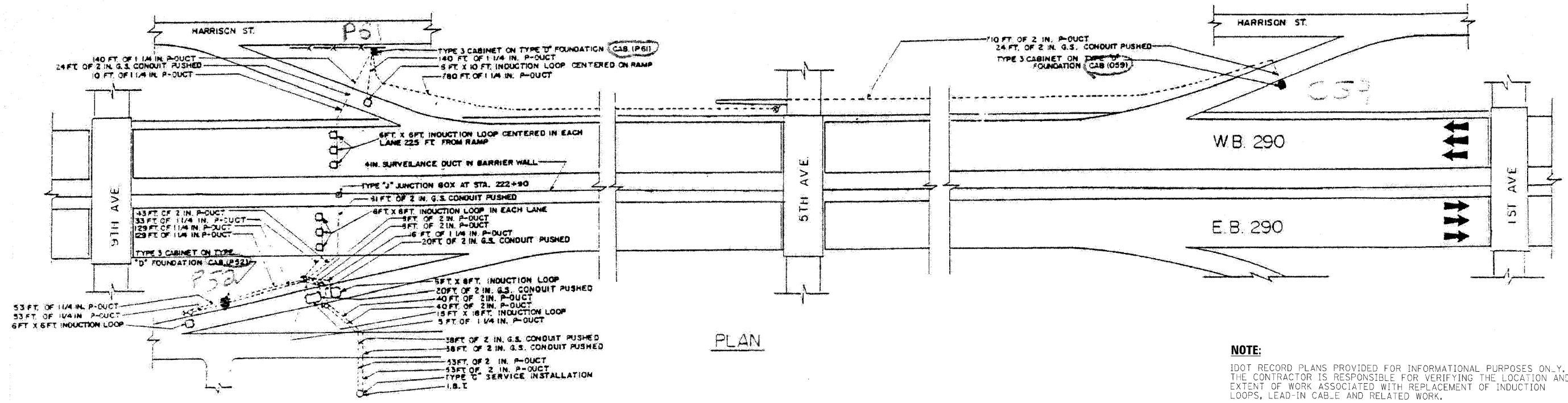

PLAN

NOTE:
 IDOT RECORD PLANS PROVIDED FOR INFORMATIONAL PURPOSES ONLY. THE CONTRACTOR IS RESPONSIBLE FOR VERIFYING THE LOCATION AND EXTENT OF WORK ASSOCIATED WITH REPLACEMENT OF INDUCTION LOOPS, LEAD-IN CABLE AND RELATED WORK.

SUMMARY OF QUANTITIES (THIS SHEET)		
DESCRIPTION	UNIT	QUANTITY
ELECTRIC CABLE IN CONDUIT, LEAD-IN, NO. 18 4/C, TWISTED, SHIELDED	LF	1316
INDUCTION LOOP	LF	378

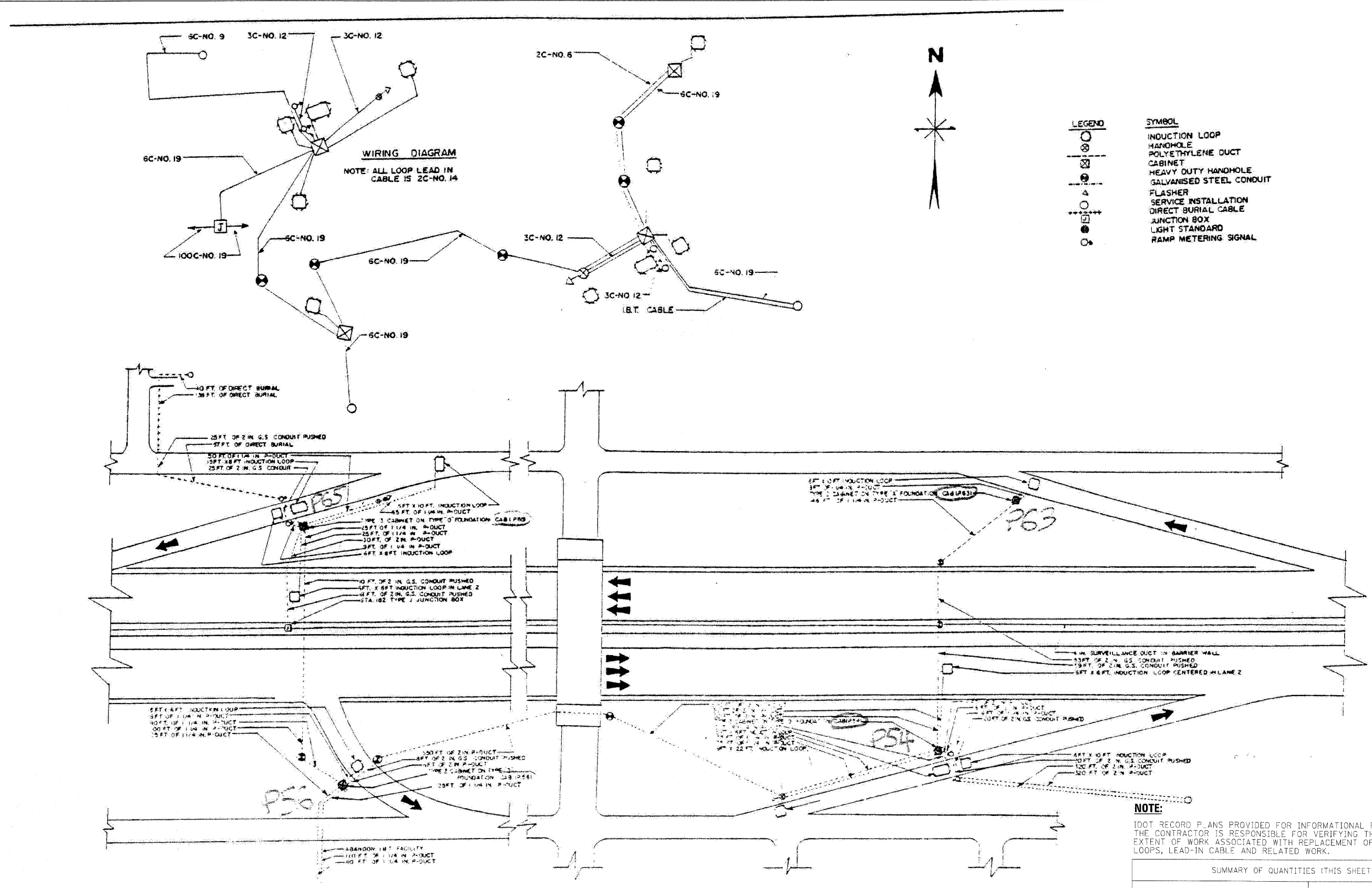

NOTE:
 IDOT RECORD P-ANS PROVIDED FOR INFORMATIONAL PURPOSES ONLY. THE CONTRACTOR IS RESPONSIBLE FOR VERIFYING THE LOCATION AND EXTENT OF WORK ASSOCIATED WITH REPLACEMENT OF INDUCTION LOOPS, LEAD-IN CABLE AND RELATED WORK.

SUMMARY OF QUANTITIES (THIS SHEET)		
DESCRIPTION	UNIT	QUANTITY
ELECTRIC CABLE IN CONDUIT, LEAD-IN, NO. 18 4/C, TWISTED, SHIELDED	LF	302
INDUCTION LOOP	LF	399

FILE NAME =	DESIGNED - GHT	REVISED -
...:\signal\prp\In_ABC_C21_vs_291.dgn	DRAWN - TWB	REVISED -
USER NAME = tblank	CHECKED - MPM	REVISED -
PLOT DATE = 11/12/2009	DATE - 10/16/09	REVISED -

benesch

**STATE OF ILLINOIS
 DEPARTMENT OF TRANSPORTATION**

**TRAFFIC SURVEILLANCE
 17TH AVE INSTALLATION**

SCALE: N.T.S. SHEET NO. 9 OF 16 SHEETS STA. TO STA.

F.A.I. RTE.	SECTION	COUNTY	TOTAL SHEETS	SHEET NO.
290	(3031.1, ETC., 383B)RS-5	COOK	298	260
CONTRACT NO. 60G52				
FED. ROAD DIST. NO. ILLINOIS FED. AID PROJECT				

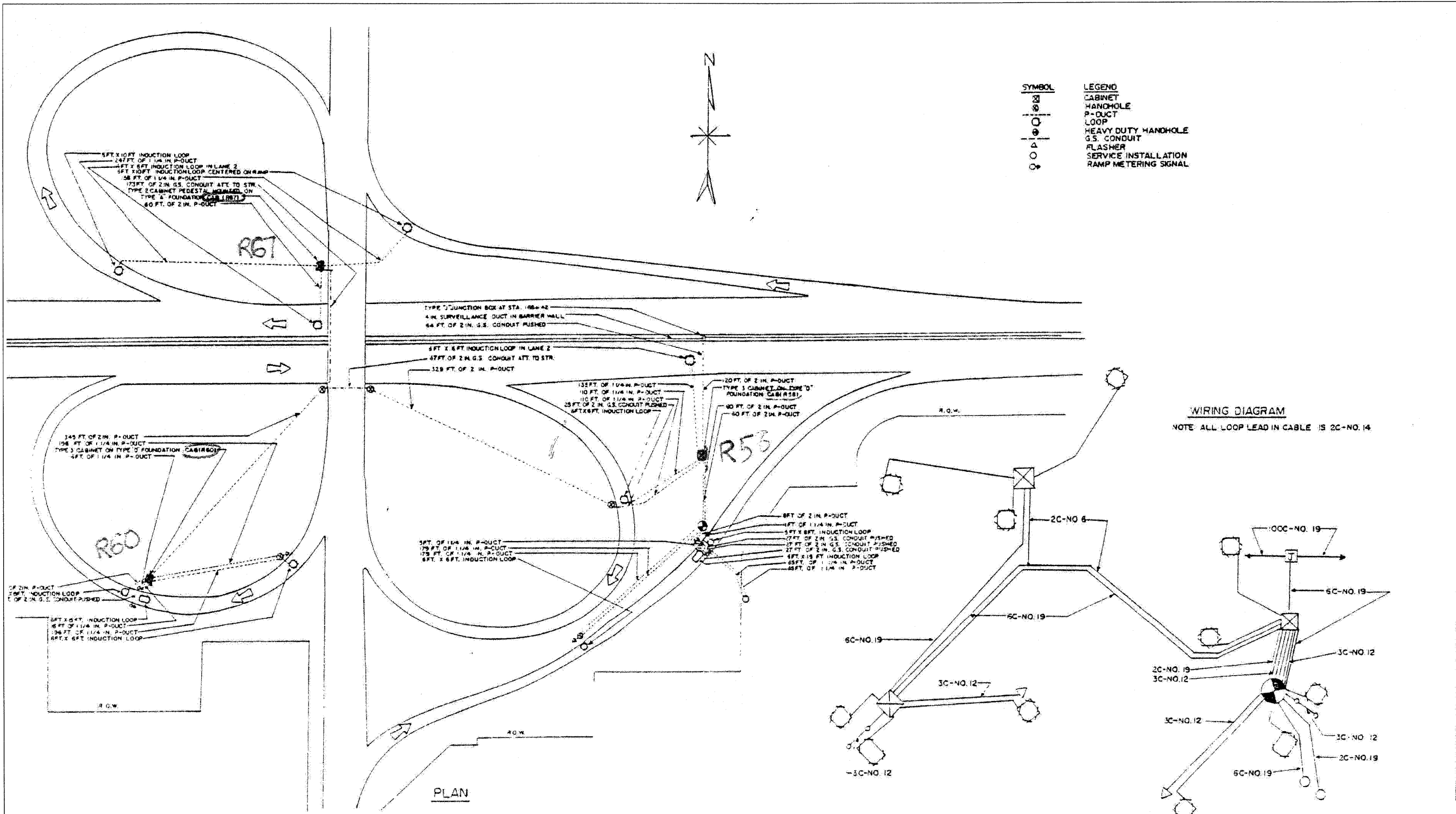

WIRING DIAGRAM
NOTE: ALL LOOP LEAD IN CABLE IS 2C-NO. 14

NOTE:
IDOT RECORD PLANS PROVIDED FOR INFORMATIONAL PURPOSES ONLY. THE CONTRACTOR IS RESPONSIBLE FOR VERIFYING THE LOCATION AND EXTENT OF WORK ASSOCIATED WITH REPLACEMENT OF INDUCTION LOOPS, LEAD-IN CABLE AND RELATED WORK.

SUMMARY OF QUANTITIES (THIS SHEET)		
DESCRIPTION	UNIT	QUANTITY
ELECTRIC CABLE IN CONDUIT, LEAD-IN, NO. 18 4/C, TWISTED, SHIELDED	LF	1503
INDUCTION LOOP	LF	369

FILE NAME =	DESIGNED - GHT	REVISED -
...signals\corp\in_abc_c2.ta.10.dgn	DRAWN - TMB	REVISED -
USER NAME = tblank	CHECKED - MPM	REVISED -
PLOT DATE = 11/12/2009	DATE - 10/16/09	REVISED -

benesch

**STATE OF ILLINOIS
DEPARTMENT OF TRANSPORTATION**

**TRAFFIC SURVEILLANCE
25TH AVE INSTALLATION**

SCALE: N.T.S. SHEET NO. 10 OF 16 SHEETS STA. TO STA.

F.A.I. RTE.	SECTION	COUNTY	TOTAL SHEETS	SHEET NO.
290	(3031.1, ETC., 3838)RS-5	COOK	298	261
CONTRACT NO. 60G52				
FED. ROAD DIST. NO. ILLINOIS FED. AID PROJECT				

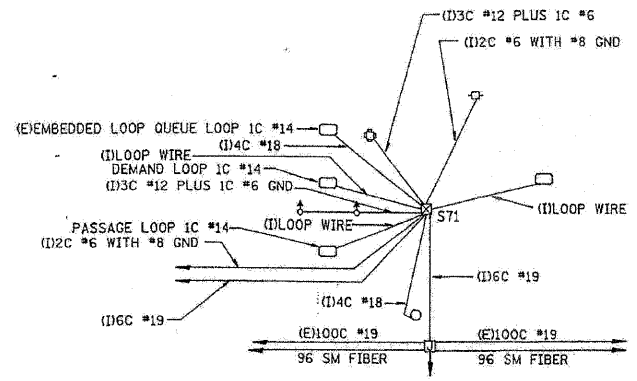
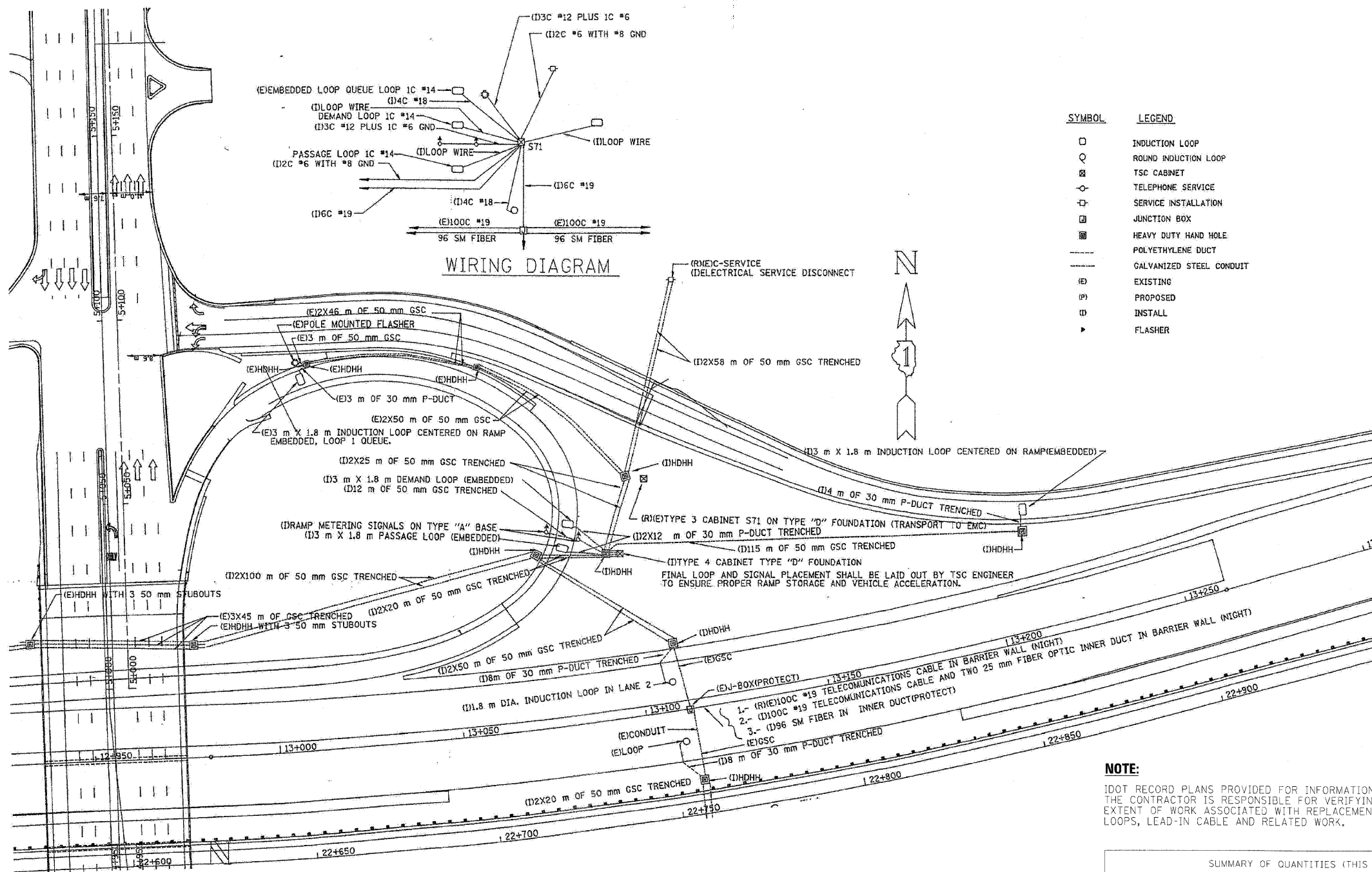

SYMBOL	LEGEND
○	INDUCTION LOOP
⊙	ROUND INDUCTION LOOP
⊠	TSC CABINET
⊕	TELEPHONE SERVICE
⊖	SERVICE INSTALLATION
⊞	JUNCTION BOX
⊟	HEAVY DUTY HAND HOLE
---	POLYETHYLENE DUCT
---	GALVANIZED STEEL CONDUIT
(E)	EXISTING
(P)	PROPOSED
(I)	INSTALL
▶	FLASHER

NOTE:
 IDOT RECORD PLANS PROVIDED FOR INFORMATIONAL PURPOSES ONLY. THE CONTRACTOR IS RESPONSIBLE FOR VERIFYING THE LOCATION AND EXTENT OF WORK ASSOCIATED WITH REPLACEMENT OF INDUCTION LOOPS, LEAD-IN CABLE AND RELATED WORK.

SUMMARY OF QUANTITIES (THIS SHEET)		
DESCRIPTION	UNIT	QUANTITY
ELECTRIC CABLE IN CONDUIT, LEAD-IN, NO. 18 4/C, TWISTED, SHIELDED	LF	448
INDUCTION LOOP	LF	72

FILE NAME =	DESIGNED - GHT	REVISED -
...:\signals\prp\in_abc_c2_ts_12.dgn	DRAWN - TMB	REVISED -
USER NAME = tblank	CHECKED - MPM	REVISED -
PLOT DATE = 11/12/2009	DATE - 10/16/09	REVISED -

benesch

**STATE OF ILLINOIS
 DEPARTMENT OF TRANSPORTATION**

**TRAFFIC SURVEILLANCE
 MANHEIM RD INSTALLATION (1 OF 3)**

SCALE: N.T.S. SHEET NO. 12 OF 16 SHEETS STA. TO STA.

F.A.I. RTE.	SECTION	COUNTY	TOTAL SHEETS	SHEET NO.
290	(3031.1, ETC., 3838RS-5)	COOK	298	263
FED. ROAD DIST. NO. ILLINOIS FED. AID PROJECT			CONTRACT NO. 60652	

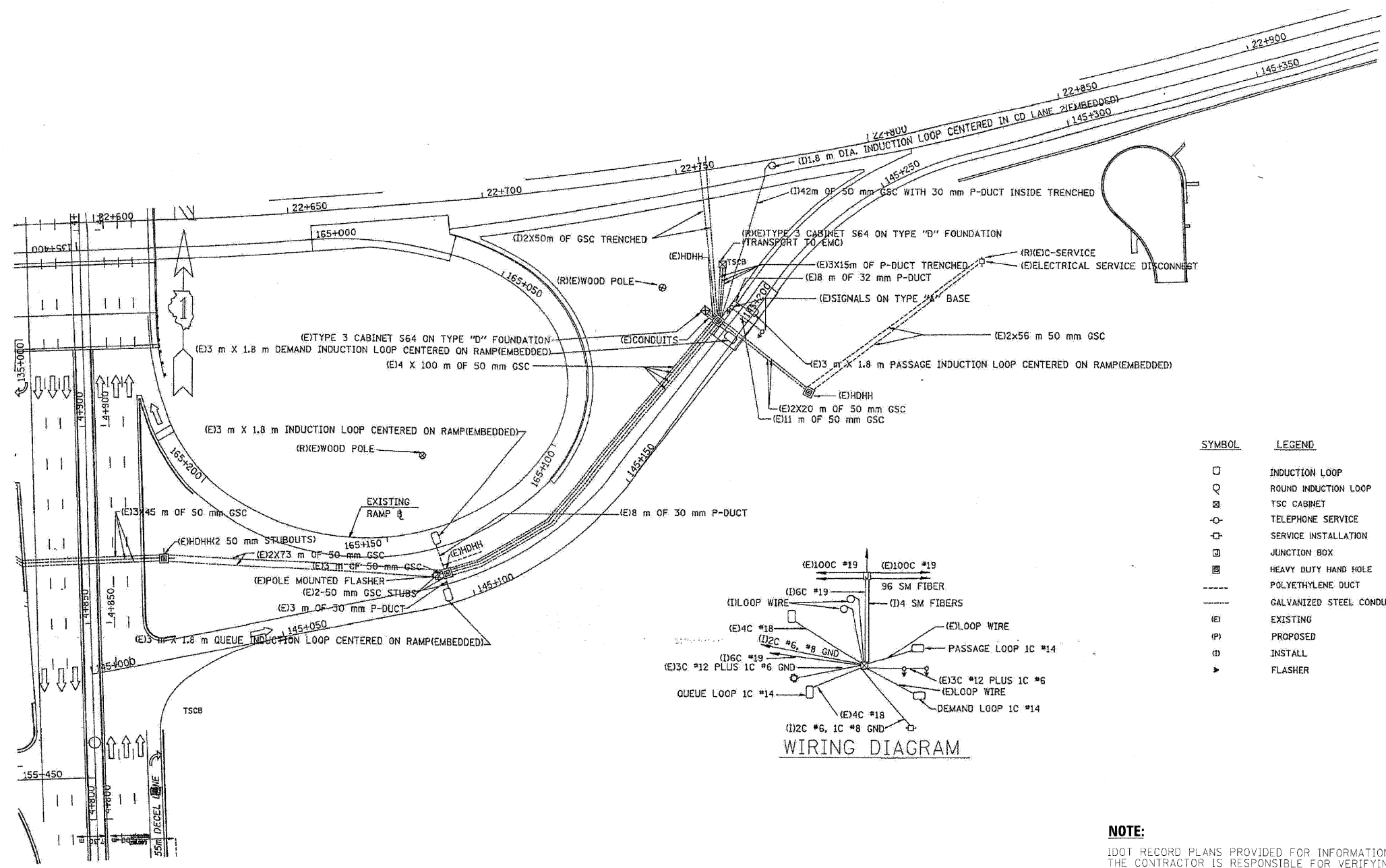

SYMBOL	LEGEND
□	INDUCTION LOOP
○	ROUND INDUCTION LOOP
⊠	TSC CABINET
⊖	TELEPHONE SERVICE
⊕	SERVICE INSTALLATION
⊞	JUNCTION BOX
⊟	HEAVY DUTY HAND HOLE
---	POLYETHYLENE DUCT
---	GALVANIZED STEEL CONDUIT
(E)	EXISTING
(P)	PROPOSED
(I)	INSTALL
▶	FLASHER

NOTE:
 IDOT RECORD PLANS PROVIDED FOR INFORMATIONAL PURPOSES ONLY. THE CONTRACTOR IS RESPONSIBLE FOR VERIFYING THE LOCATION AND EXTENT OF WORK ASSOCIATED WITH REPLACEMENT OF INDUCTION LOOPS, LEAD-IN CABLE AND RELATED WORK.

SUMMARY OF QUANTITIES (THIS SHEET)		
DESCRIPTION	UNIT	QUANTITY
ELECTRIC CABLE IN CONDUIT, LEAD-IN, NO. 18 4/C, TWISTED, SHIELDED	LF	198
INDUCTION LOOP	LF	21

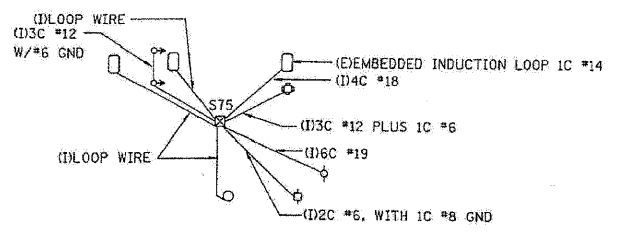
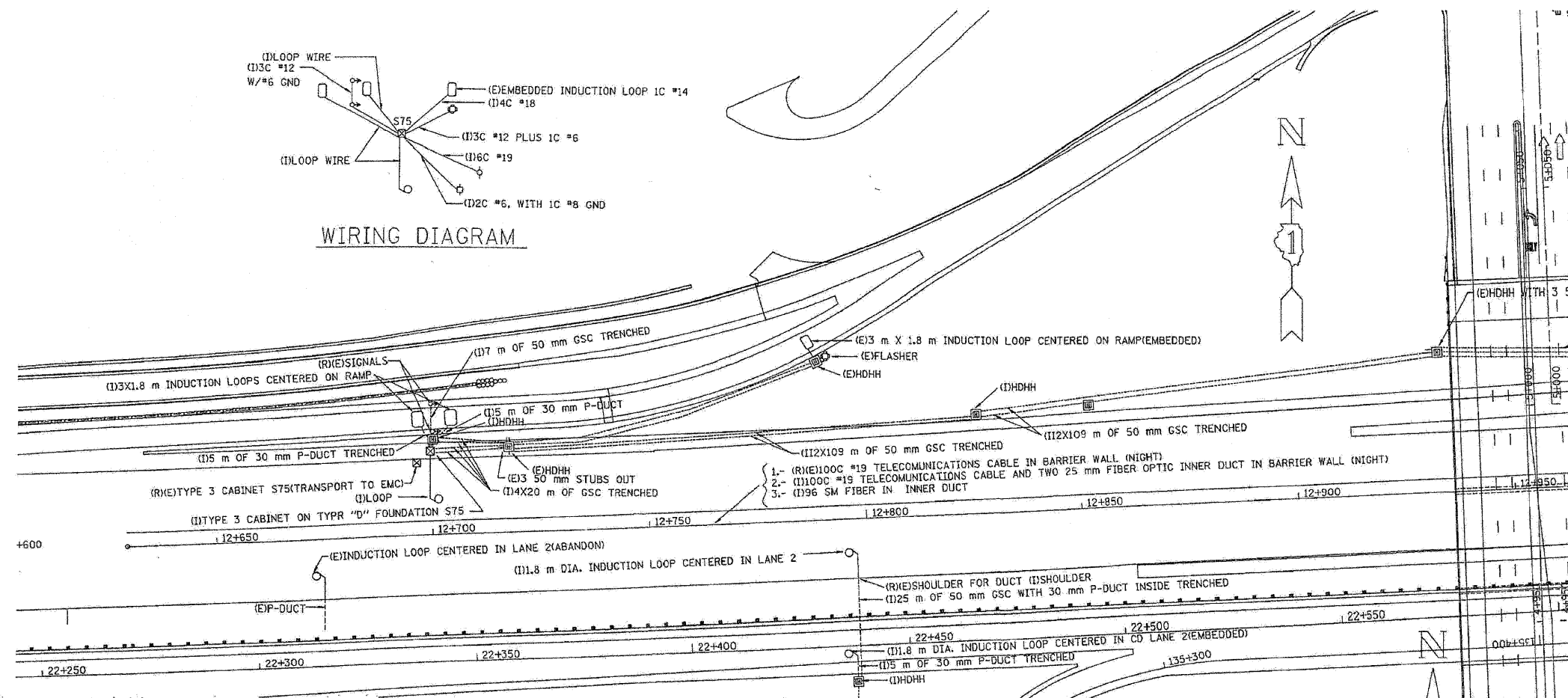

SYMBOL	LEGEND
○	INDUCTION LOOP
⊙	ROUND INDUCTION LOOP
⊗	TSC CABINET
○-○	TELEPHONE SERVICE
□-□	SERVICE INSTALLATION
⊠	JUNCTION BOX
⊞	HEAVY DUTY HAND HOLE
---	POLYETHYLENE DUCT
---	GALVANIZED STEEL CONDUIT
(E)	EXISTING
(P)	PROPOSED
(I)	INSTALL
▶	FLASHER

NOTE:
 IDOT RECORD PLANS PROVIDED FOR INFORMATIONAL PURPOSES ONLY. THE CONTRACTOR IS RESPONSIBLE FOR VERIFYING THE LOCATION AND EXTENT OF WORK ASSOCIATED WITH REPLACEMENT OF INDUCTION LOOPS, LEAD-IN CABLE AND RELATED WORK.

SUMMARY OF QUANTITIES (THIS SHEET)		
DESCRIPTION	UNIT	QUANTITY
ELECTRIC CABLE IN CONDUIT, LEAD-IN, NO. 18 4/C, TWISTED, SHIELDED	LF	96
INDUCTION LOOP	LF	84

FILE NAME =	DESIGNED - GHT	REVISED -
...signals\ppp\in_abc_c2_ts_14.dgn	DRAWN - TMB	REVISED -
USER NAME = tblank	CHECKED - MPM	REVISED -
PLOT DATE = 11/12/2009	DATE - 10/16/09	REVISED -

benesch

**STATE OF ILLINOIS
DEPARTMENT OF TRANSPORTATION**

**TRAFFIC SURVEILLANCE
MANHEIM RD INSTALLATION (3 OF 3)**

SCALE: N.T.S. SHEET NO. 14 OF 16 SHEETS STA. TO STA.

F.A.I. RTE.	SECTION	COUNTY	TOTAL SHEETS	SHEET NO.
290	13031.I, ETC., 3838)RS-5	COOK	298	265
FED. ROAD DIST. NO. ILLINOIS FED. AID PROJECT			CONTRACT NO. 60652	

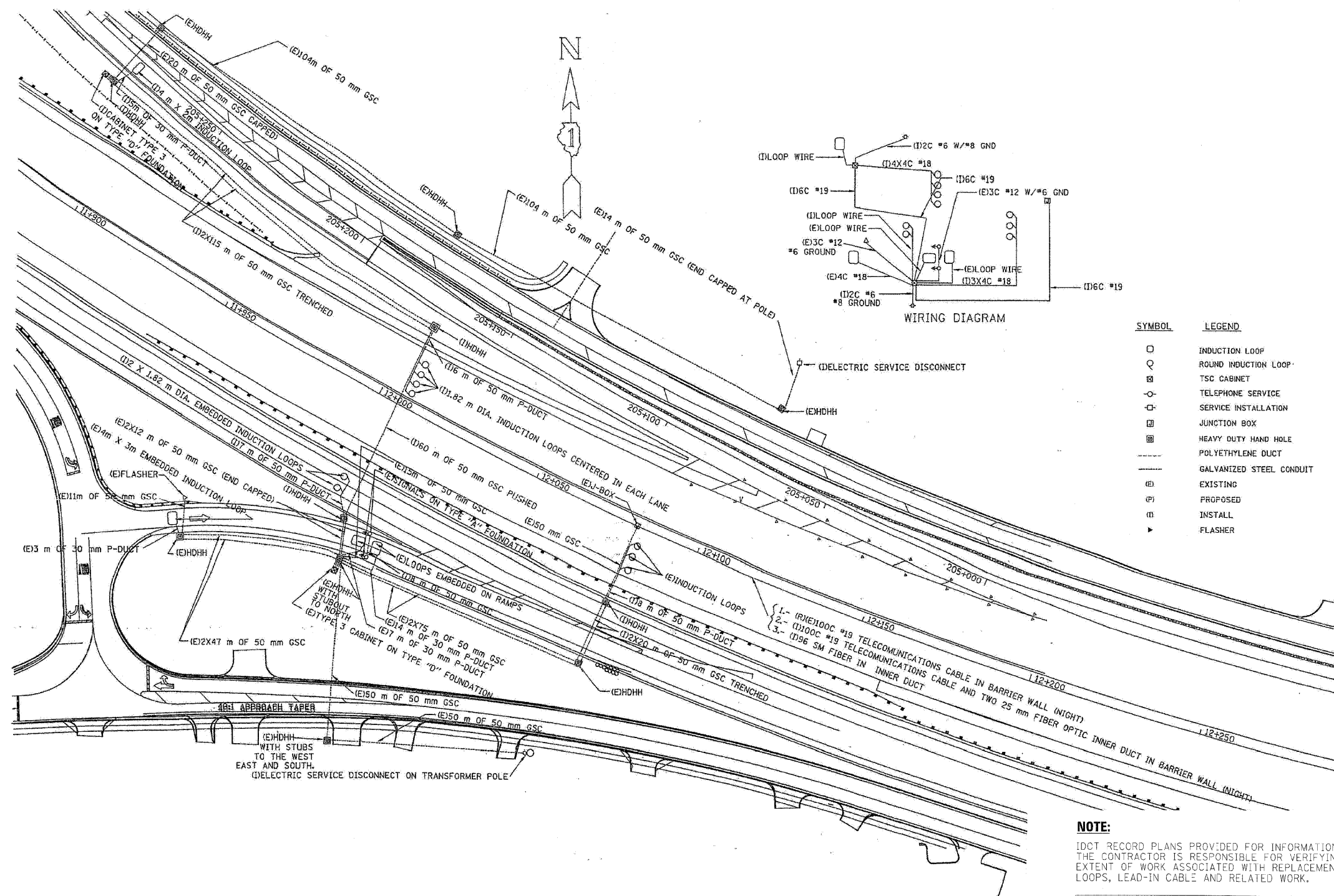

NOTE:
 IDOT RECORD PLANS PROVIDED FOR INFORMATIONAL PURPOSES ONLY. THE CONTRACTOR IS RESPONSIBLE FOR VERIFYING THE LOCATION AND EXTENT OF WORK ASSOCIATED WITH REPLACEMENT OF INDUCTION LOOPS, LEAD-IN CABLE AND RELATED WORK.

SUMMARY OF QUANTITIES (THIS SHEET)		
DESCRIPTION	UNIT	QUANTITY
ELECTRIC CABLE IN CONDUIT, LEAD-IN, NO. 18 4/C, TWISTED, SHIELDED	LF	2687
INDUCTION LOOP	LF	276

FILE NAME =	DESIGNED - GHT	REVISED -
...signals\prp\in.ABC.C2-ts_16.dgn	DRAWN - TMB	REVISED -
USER NAME = tblank	CHECKED - MPM	REVISED -
PLT DATE = 11/12/2009	DATE - 10/16/09	REVISED -

benesch

**STATE OF ILLINOIS
 DEPARTMENT OF TRANSPORTATION**

**TRAFFIC SURVEILLANCE
 W. OF MANHEIM RD HILLSIDE INSTALLATION**

SCALE: N.T.S. SHEET NO. 15 OF 16 SHEETS STA. TO STA.

F.A.I. RTE.	SECTION	COUNTY	TOTAL SHEETS	SHEET NO.
290	(3031.1, ETC., 3838RS-5)	COOK	298	266
CONTRACT NO. 60652				
FED. ROAD DIST. NO. ILLINOIS FED. AID PROJECT				

F.A. RTE.	SECTION	COUNTY	TOTAL SHEETS	SHEET NO.
STA.	TO STA.			
FED. ROAD DIST. NO.		ILLINOIS FED. AID PROJECT		

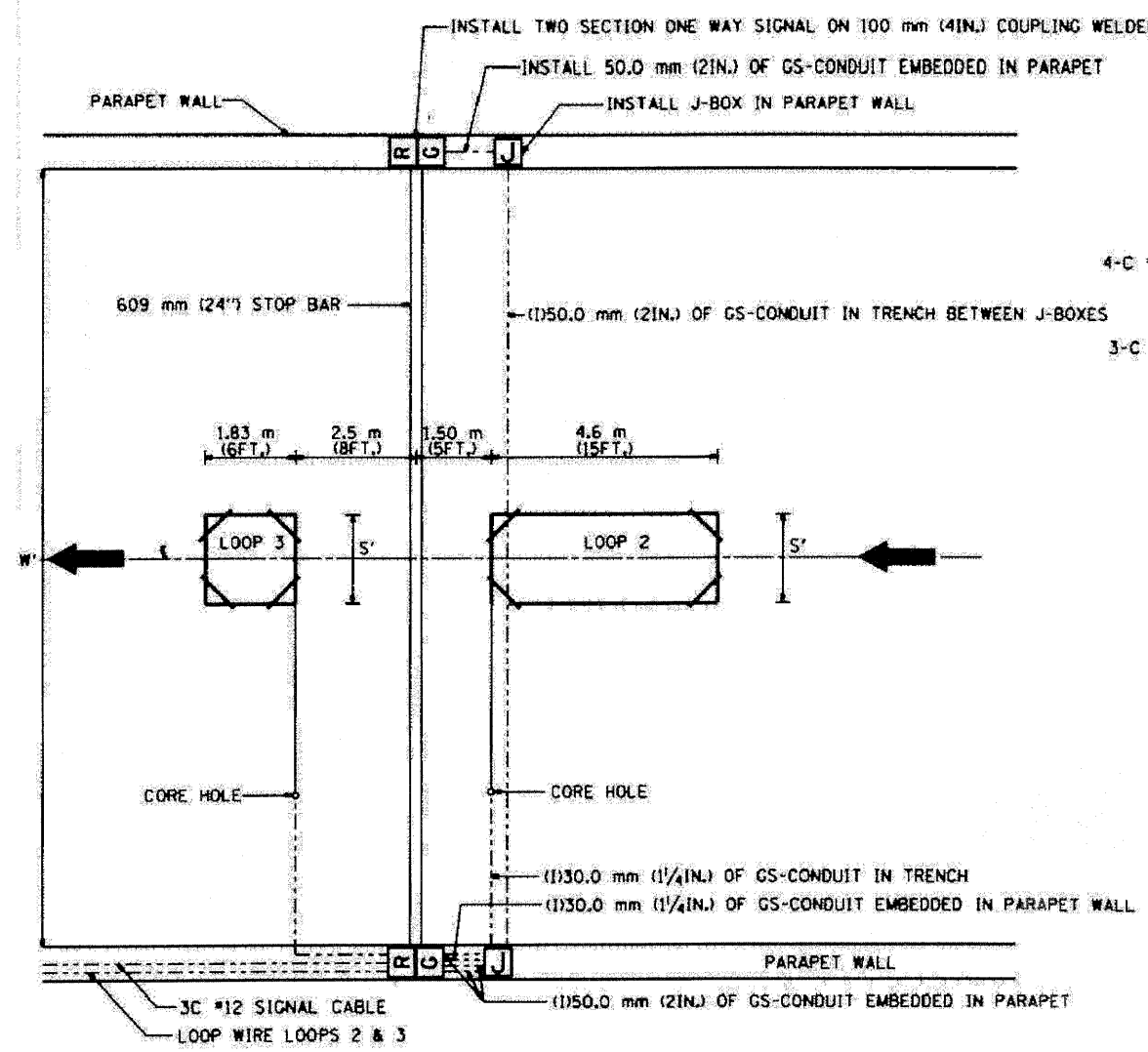

TYPICAL LOOP LAYOUT

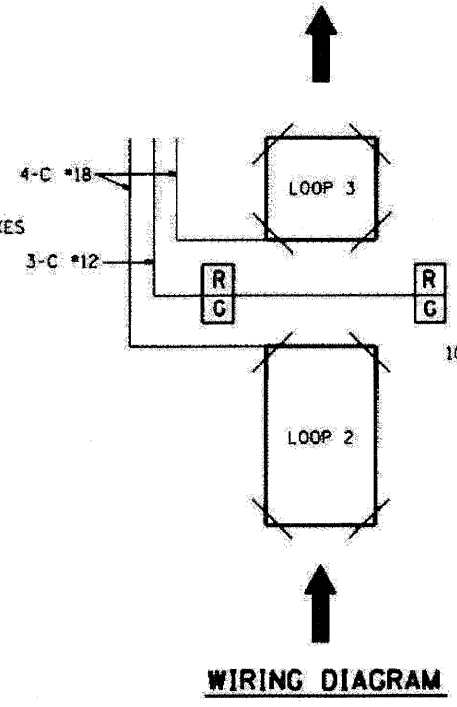

WIRING DIAGRAM

- NOTES**
1. EACH LOOP SHALL BE SPliced TO A 4-C NO.18 TWISTED SHIELDED LEAD IN WHEN 45 m (150FT.) OR MORE FROM CABINET.
 2. LOOPS SHALL BE SPliced IN HANDHOLES OR J-BOX ONLY, OTHERWISE WRITTEN PERMISSION SHALL BE OBTAINED FROM TSC ENGINEER.
 3. LOOPS SHALL NOT BE SPliced IN SERIES.
 4. EACH LOOP LEAD IN SHALL BE IDENTIFIED AND PERMANENTLY COLOR CODED IN THE COREHOLE, HANDHOLE & CABINETS THRU WHICH THEY ENTER OR PASS AND TAGGED WITH THE CORRECT NOMENCLATURES.

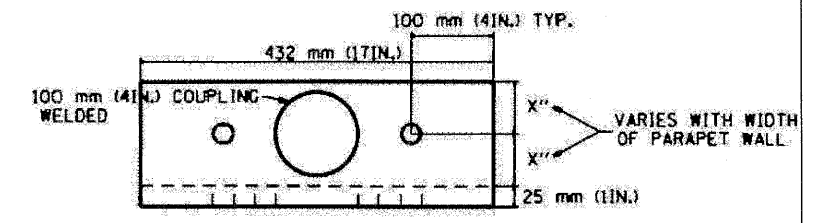

TOP

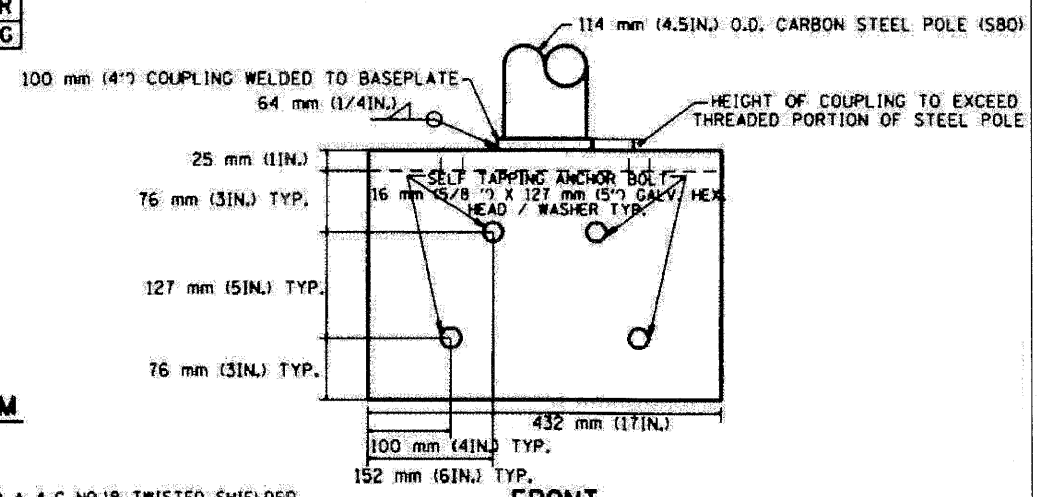

FRONT

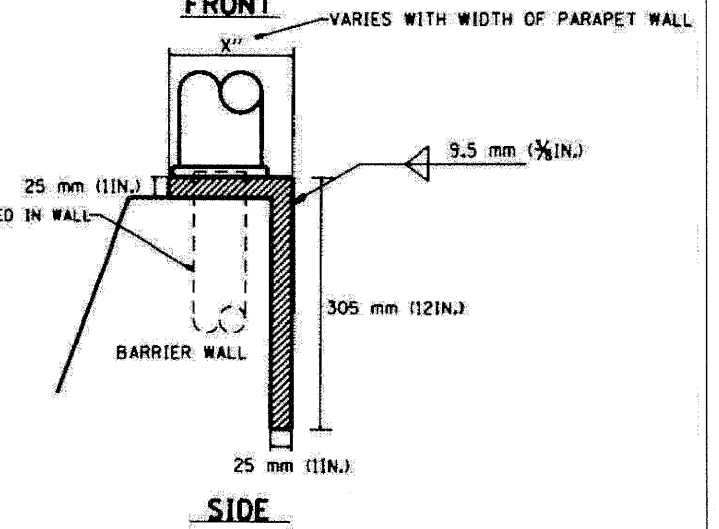

SIDE

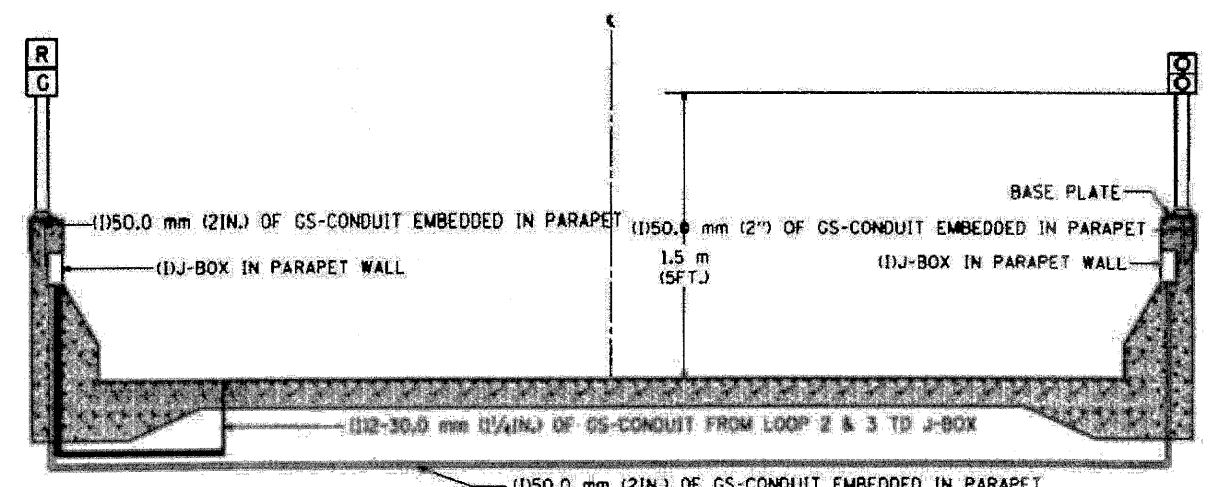

SECTION

WIDTH (W)	WIDTH (S)
3.7 m (12')	2.5 m (8')
4.0 m (13')	2.8 m (9')
4.3 m (14')	3.1 m (10')
4.6 m (15')	3.4 m (11')
4.9 m (16')	3.7 m (12')
5.2 m (17')	4.0 m (13')
5.5 m (18')	4.3 m (14')
5.8 m (19')	4.6 m (15')
6.1 m (20')	4.9 m (16')
6.4 m (21')	5.2 m (17')
6.7 m (22')	5.5 m (18')
7.0 m (23')	5.8 m (19')
7.3 m (24')	6.1 m (20')
7.6 m (25')	6.4 m (21')

REVISIONS		ILLINOIS DEPARTMENT OF TRANSPORTATION TRAFFIC SYSTEMS CENTER TYPICAL RAMP METERING TYPE 3 BARRIER WALL INSTALLATION
NO.	DATE	
1.	6/94	SCALE: VERT. NONE HORIZ. NONE DATE: 6-22-94
2.	2/96	
3.	3/96	
4.	2/98	
		DRAWN BY: G.M. CHECKED BY: R.L.

TRAFFIC SYSTEMS CENTER (TY-1TSC-400#3)

FILE NAME *	DESIGNED - GHT	REVISED -
...:\pp\in_ABC\22_TS_DET_03.dgn	DRAWN - TMB	REVISED -
USER NAME * tblank	CHECKED - MPM	REVISED -
PLOT DATE * 11/12/2009	DATE - 10/16/09	REVISED -

benesch

**STATE OF ILLINOIS
DEPARTMENT OF TRANSPORTATION**

**TRAFFIC SYSTEMS CENTER
DETAIL SHEETS**

SCALE: N.T.S.	SHEET NO. 3 OF 16 SHEETS	STA. TO STA.
---------------	--------------------------	--------------

F.A. RTE.	SECTION	COUNTY	TOTAL SHEETS	SHEET NO.
290	13031J, ETC., 3830RS-5	COOK	298	270
FED. ROAD DIST. NO.		ILLINOIS FED. AID PROJECT		
		CONTRACT NO. 60G52		

F.A. RTE.	SECTION	COUNTY	TOTAL SHEETS	SHEET NO.
STA.	TO STA.			
FED. ROAD DIST. NO.	ILLINOIS FED. AID PROJECT			

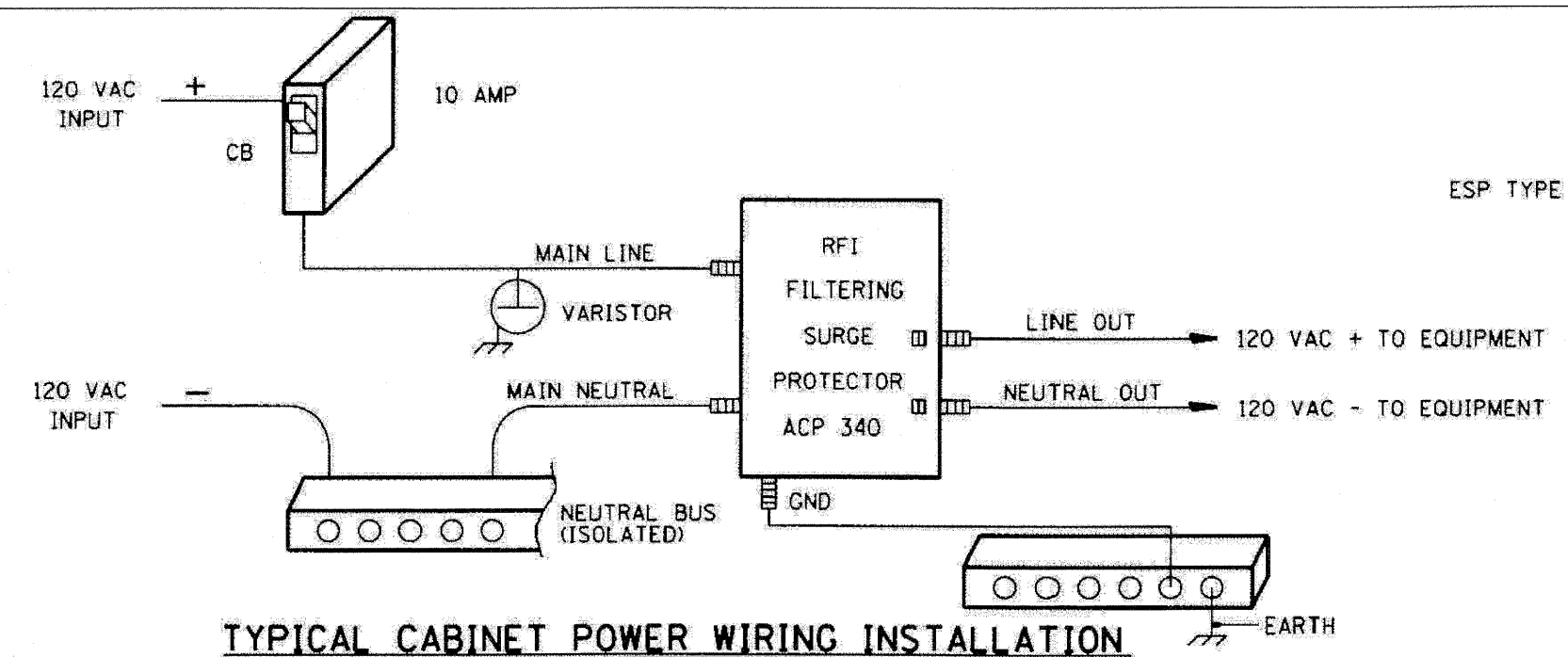

ESP TYPE 2 CABINET PEDESTAL MOUNTED

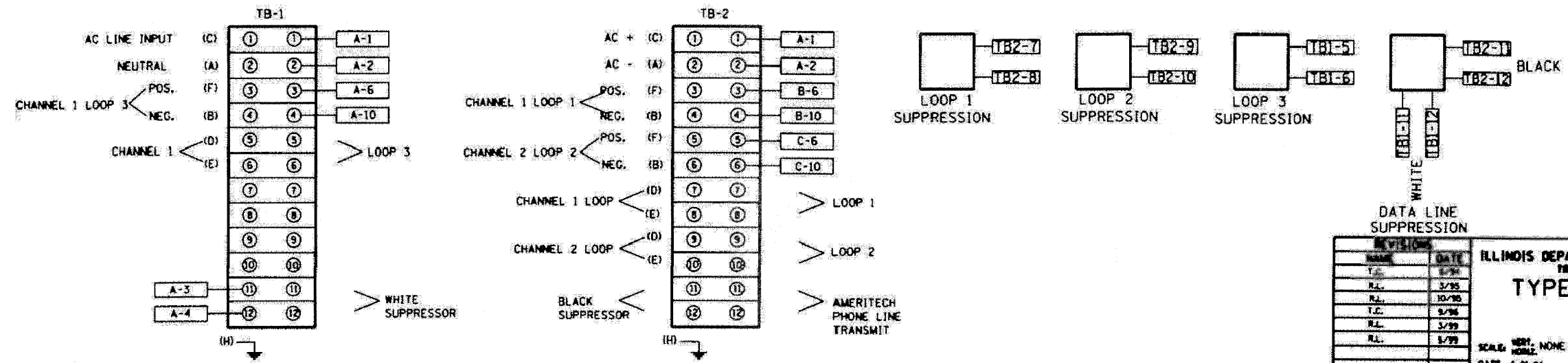
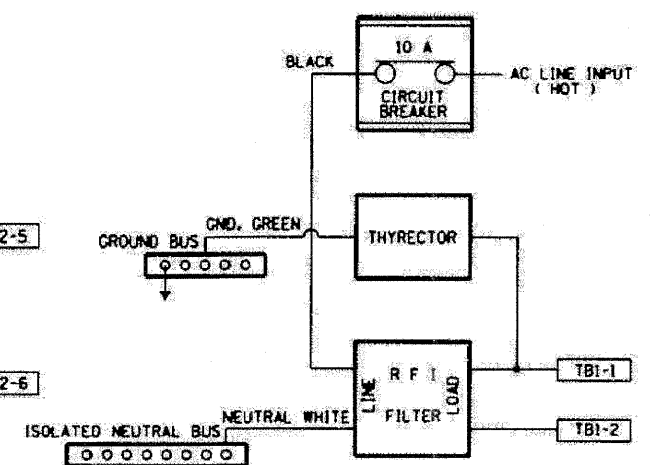
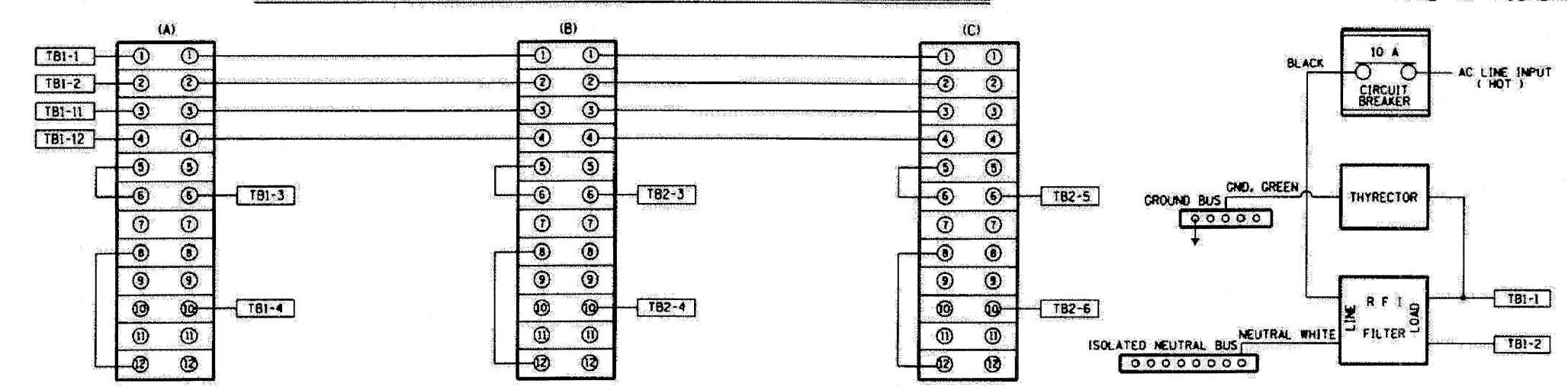
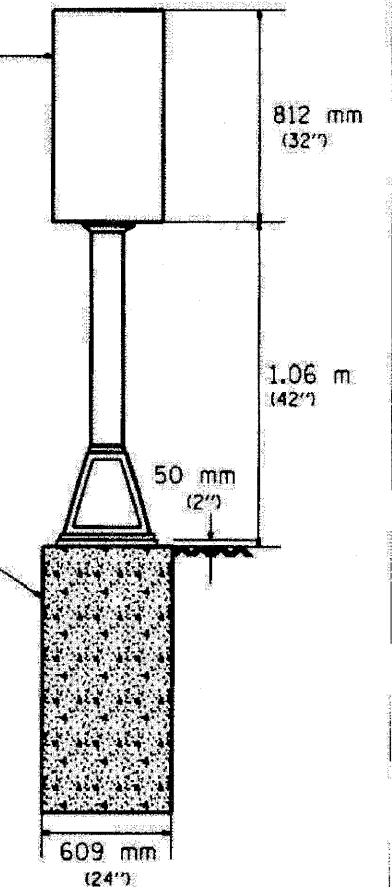

REVISIONS		DATE	DRAWN BY	CHECKED BY
NO.	DESCRIPTION			
1		8/94		
2		3/95		
3		10/98		
4		8/98		
5		3/99		
6		8/99		

ILLINOIS DEPARTMENT OF TRANSPORTATION
TRAFFIC SYSTEMS CENTER
TYPE II CABINET WIRING

SCALE: NONE
DATE: 6-21-94

DRAWN BY: G.M.
CHECKED BY: T.C.

TRAFFIC SYSTEMS CENTER (TY-1TSC-400*5)

FILE NAME -	DESIGNED - GHT	REVISED -
...prpIn_ABC_C2_TS_DET_04.dgn	DRAWN - TMB	REVISED -
USER NAME = tblank	CHECKED - MPM	REVISED -
PLT DATE = 11/12/2009	DATE - 10/16/09	REVISED -

benesch

STATE OF ILLINOIS
DEPARTMENT OF TRANSPORTATION

TRAFFIC SYSTEMS CENTER
DETAIL SHEETS

SCALE: N.T.S. SHEET NO. 4 OF 16 SHEETS STA. TO STA.

F.A. RTE.	SECTION	COUNTY	TOTAL SHEETS	SHEET NO.
290	(3031, ETC., 3838RS-5	COOK	298	271
FED. ROAD DIST. NO.	ILLINOIS FED. AID PROJECT		CONTRACT NO. 60652	

BACK VIEW OF TONE RACK

F.A.I. RTE.	SECTION	COUNTY	TOTAL SHEETS	SHEET NO.
STA. _____ TO STA. _____		ILLINOIS FED. AID PROJECT		
FED. ROAD DIST. NO. _____				

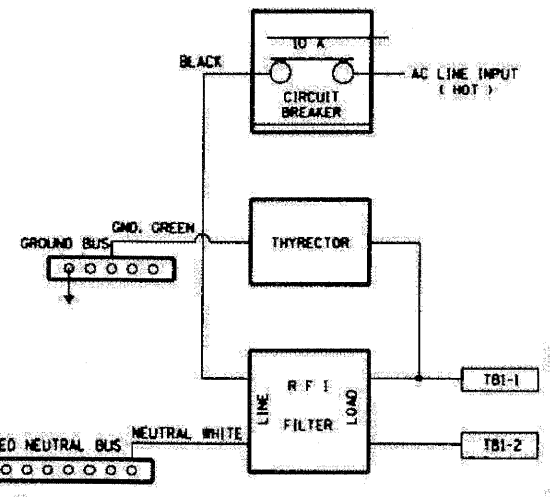
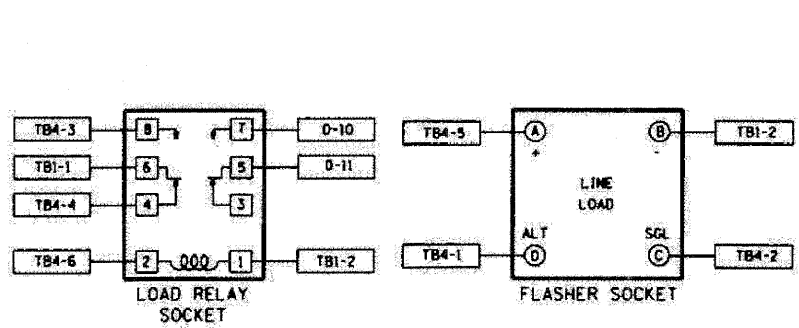
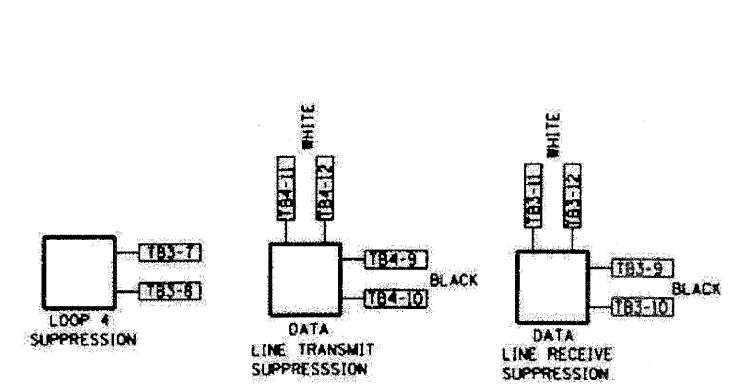
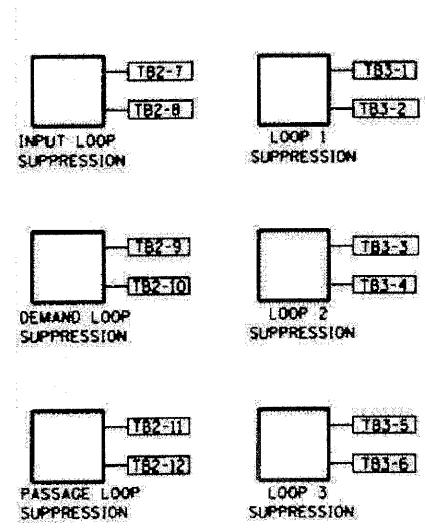
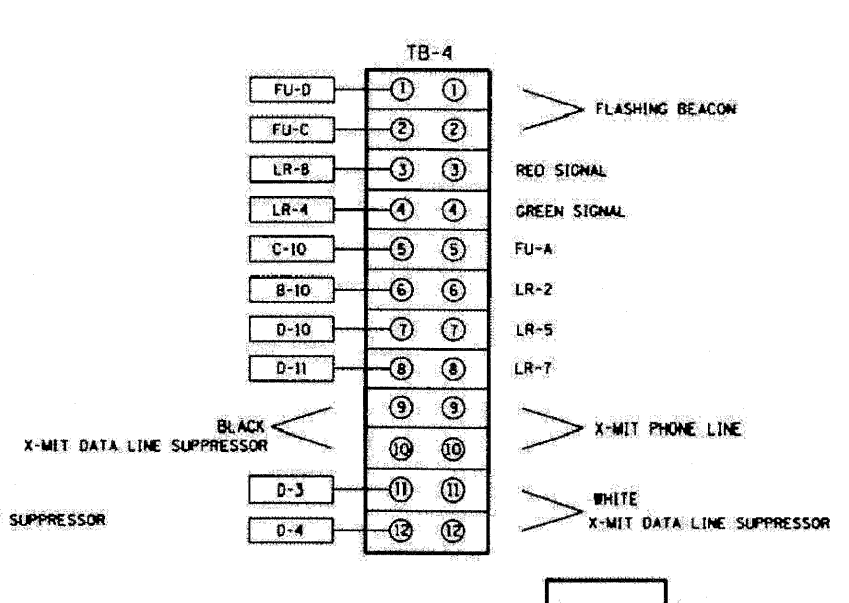
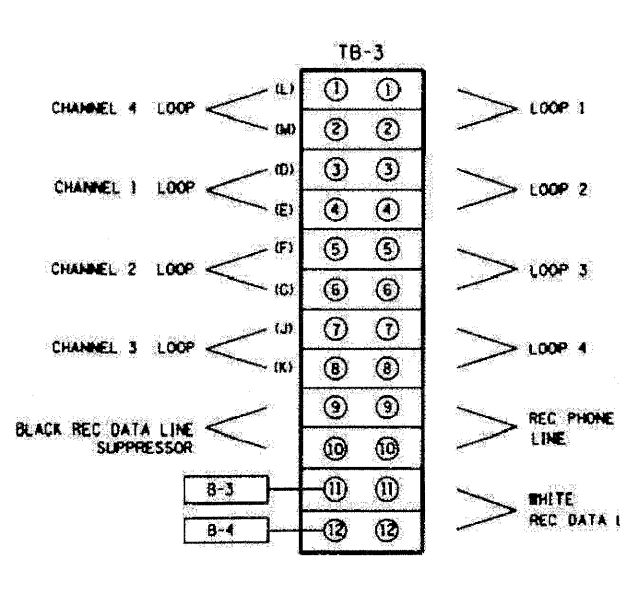
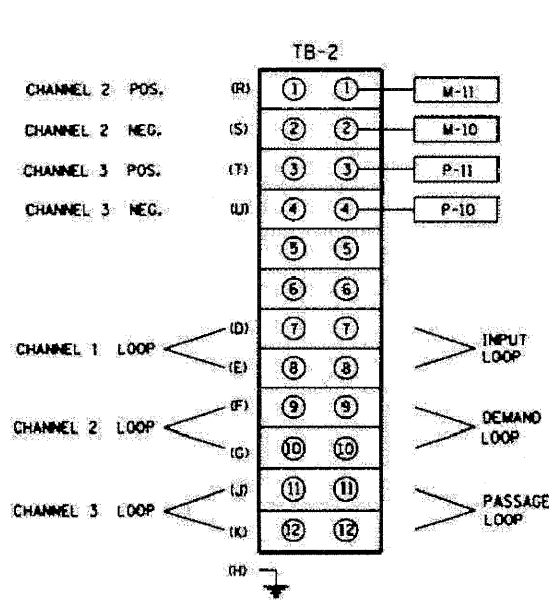
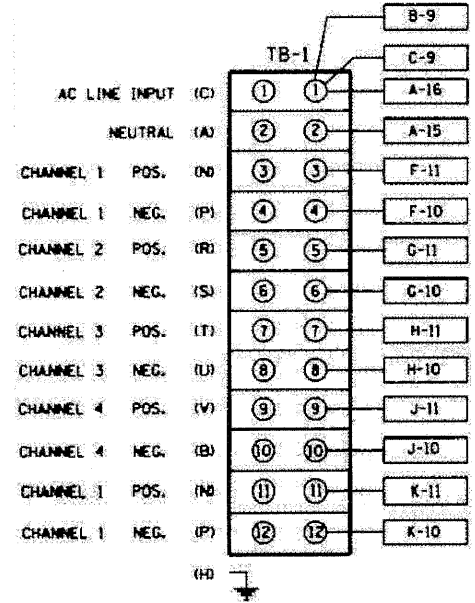
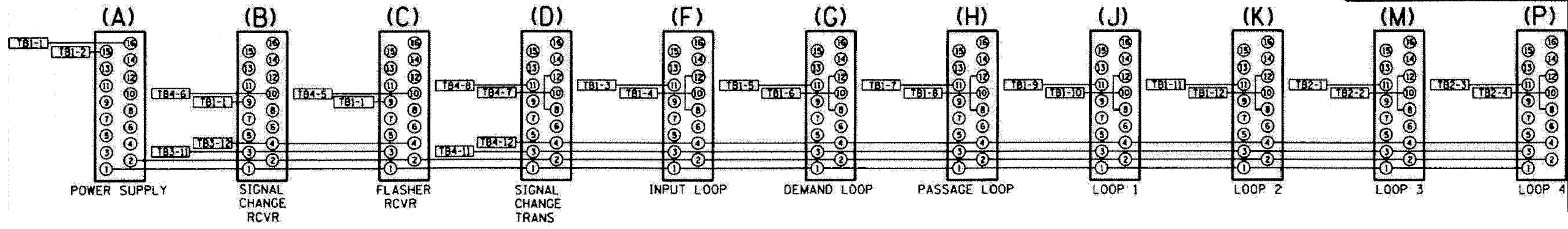

REVISIONS		ILLINOIS DEPARTMENT OF TRANSPORTATION TRAFFIC SYSTEMS CENTER	
NAME	DATE	METERING CABINET WIRING DIAGRAM SCALE: VERT. NONE HORIZ. NONE DATE 6/21/94 DRAWN BY G.M. CHECKED BY T.C.	
T.C.	6/94		
R.A.	3/95		
R.A.	5/95		

TRAFFIC SYSTEMS CENTER (TY-1TSC-400*8)

FILE NAME =	DESIGNED - GHT	REVISED -
...\\ppp\in_abc\02_TS_DET_05.dgn	DRAWN - TMB	REVISED -
USER NAME = tblank	CHECKED - MPM	REVISED -
PLOT DATE = 11/12/2009	DATE - 10/16/09	REVISED -

benesch

STATE OF ILLINOIS
DEPARTMENT OF TRANSPORTATION

TRAFFIC SYSTEMS CENTER
DETAIL SHEETS

SCALE: N.T.S. SHEET NO. 5 OF 16 SHEETS STA. TO STA.

F.A.I. RTE.	SECTION	COUNTY	TOTAL SHEETS	SHEET NO.
290	130311, ETC., 3838/R5-5	COOK	298	272
FED. ROAD DIST. NO. _____			ILLINOIS FED. AID PROJECT	
			CONTRACT NO. 60G52	

F.A.I. RTE.	SECTION	COUNTY	TOTAL SHEETS	SHEET NO.
STA.	TO STA.			
FED. ROAD DIST. NO.	ILLINOIS FED. AID PROJECT			

BACK VIEW OF TONE RACK

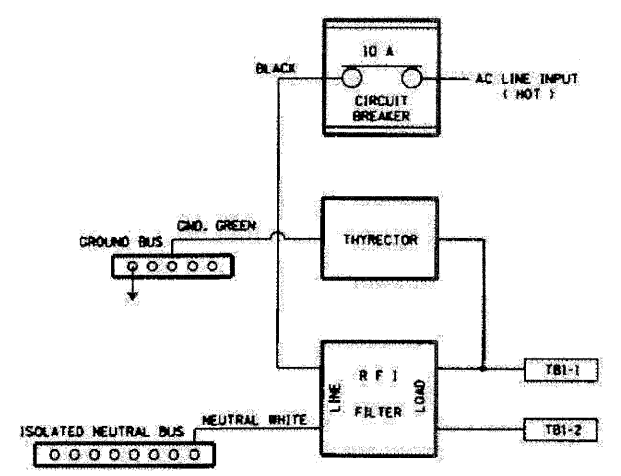
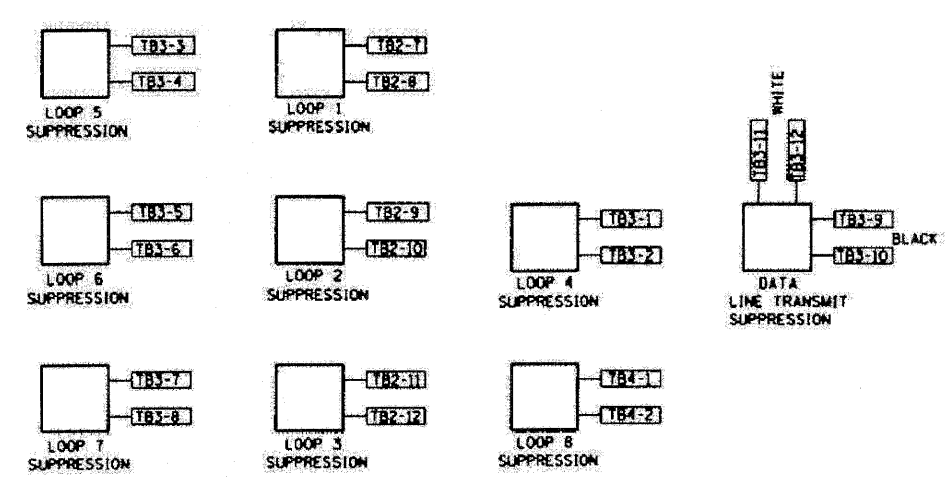
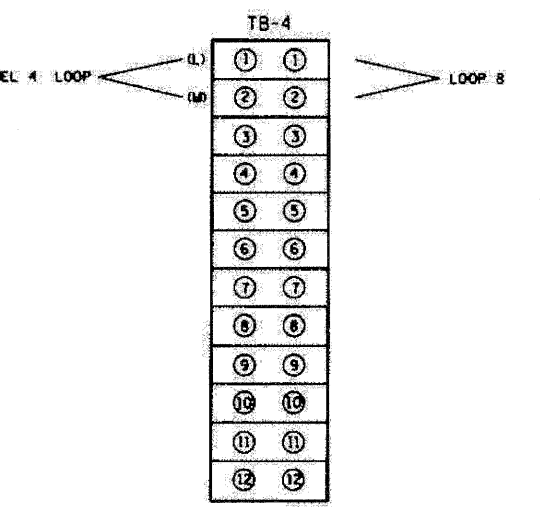
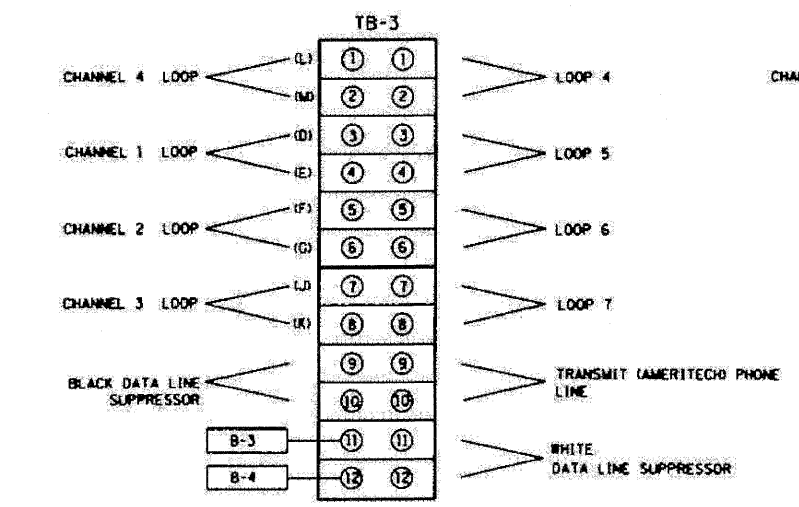
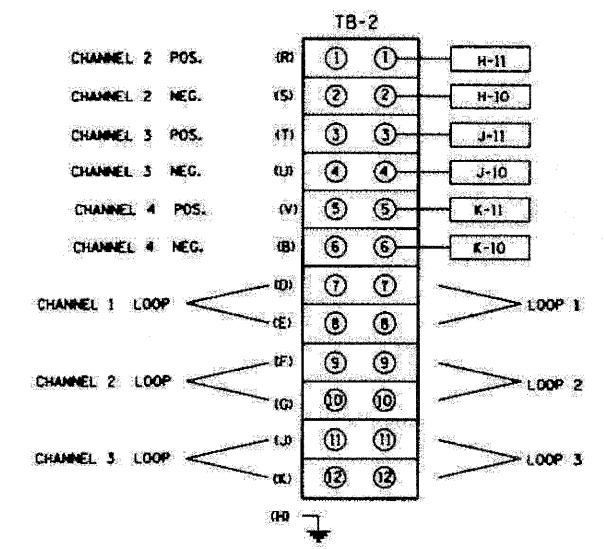
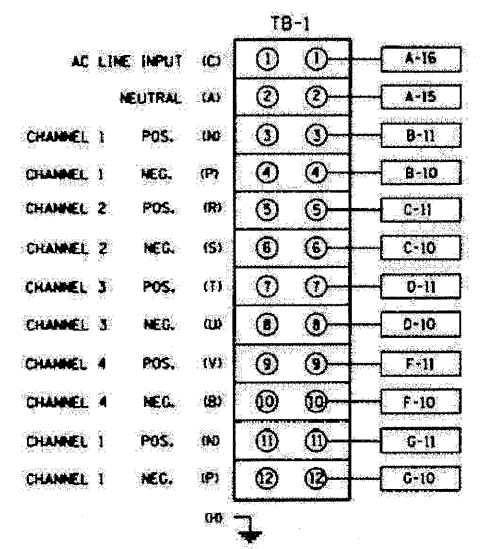
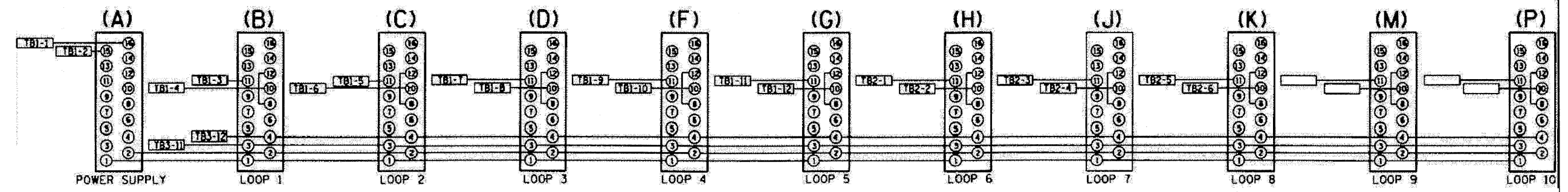

CABINET NO.		ILLINOIS DEPARTMENT OF TRANSPORTATION TRAFFIC SYSTEMS CENTER
REVISIONS	DATE	
		TYPE 3 CABINET WIRING DIAGRAM
SCALE: NONE	DATE: 10/17/95	DRAWN BY: G.M. CHECKED BY: R.L.

TRAFFIC SYSTEMS CENTER (TY-1TSC-400*13)

FILE NAME =	DESIGNED - GHT	REVISED -
...prpIn_ABC_C2_TS_DET_06.dgn	DRAWN - TMB	REVISED -
USER NAME = tblank	CHECKED - MPM	REVISED -
PLOT DATE = 11/12/2009	DATE - 10/16/09	REVISED -

benesch

STATE OF ILLINOIS
DEPARTMENT OF TRANSPORTATION

TRAFFIC SYSTEMS CENTER DETAIL SHEETS	
SCALE: N.T.S.	SHEET NO. 6 OF 16 SHEETS
STA.	TO STA.

F.A.I. RTE.	SECTION	COUNTY	TOTAL SHEETS	SHEET NO.
290	(3031, ETC., 3838)RS-5	COOK	298	273
FED. ROAD DIST. NO.			ILLINOIS FED. AID PROJECT	
			CONTRACT NO. 60652	

F.A.I. RTE.	SECTION	COUNTY	TOTAL SHEETS	SHEET NO.
STA.	TO STA.			
FED. ROAD DIST. NO.		ILLINOIS FED. AID PROJECT		

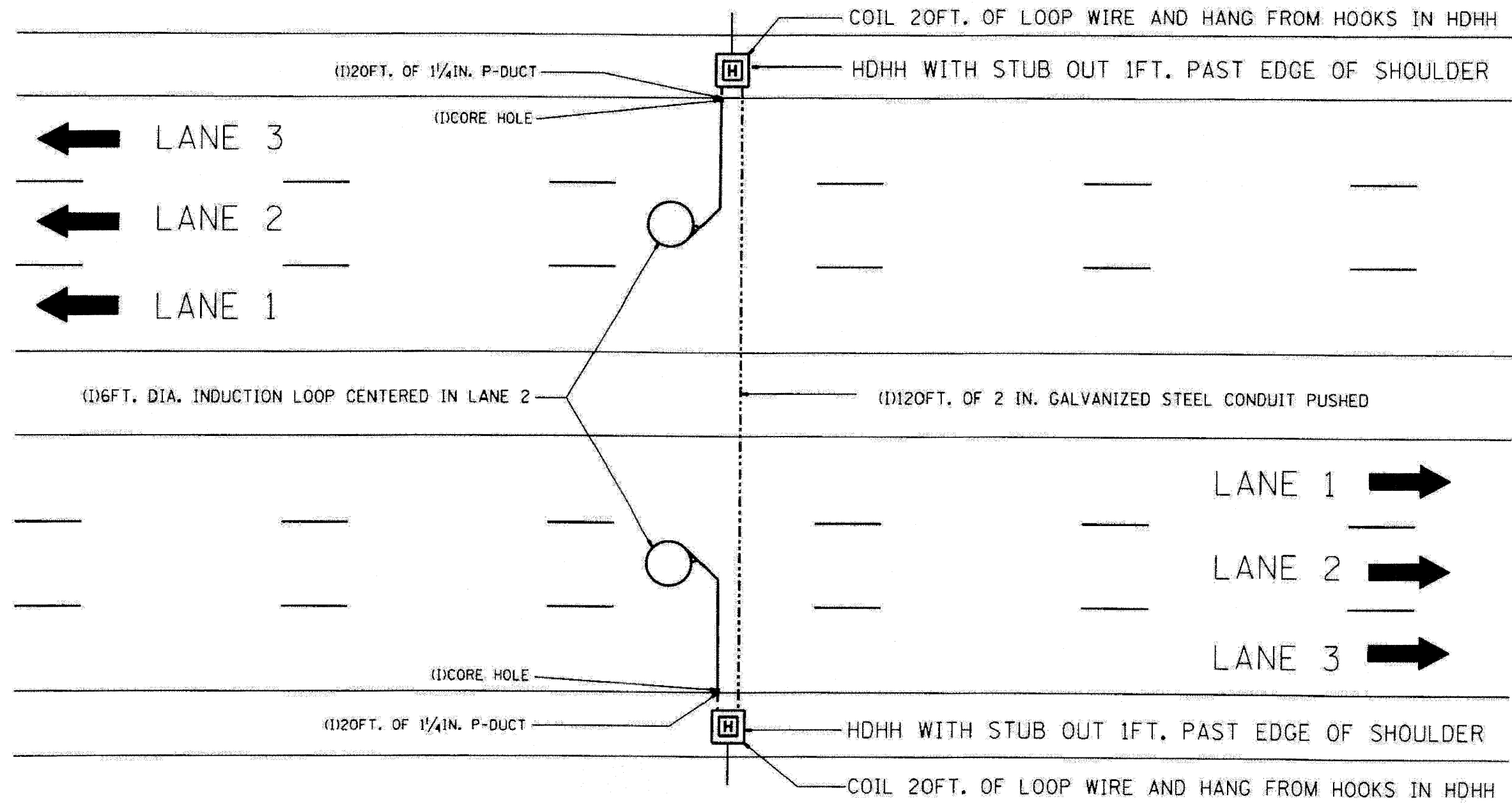

NOTE:
 THE COST OF LOOP WIRE IN HDHH IS INCIDENTAL TO THE INDUCTION LOOP,
 IT SHALL NOT BE MEASURE FOR PAYMENT.
 INSTALL AT STATIONS.

REVISIONS		ILLINOIS DEPARTMENT OF TRANSPORTATION
NO.	DATE	
		ONE LANE COUNT STATION

SCALE: VERT. NONE
 DATE: 01-31-07
 DRAWN BY: C.K.
 CHECKED BY: J.C.

TRAFFIC SYSTEMS CENTER (TY-1TSC-400*31)

FILE NAME =	DESIGNED - GHT	REVISED -
...prpln_ABC.C2.TS.DET.07.dgn	DRAWN - TMB	REVISED -
USER NAME = t6.lank	CHECKED - MPM	REVISED -
PLOT DATE = 11/12/2009	DATE - 10/16/09	REVISED -

benesch

**STATE OF ILLINOIS
 DEPARTMENT OF TRANSPORTATION**

TRAFFIC SYSTEMS CENTER DETAIL SHEETS	
SCALE: N.T.S.	SHEET NO. 7 OF 16 SHEETS STA. TO STA.

F.A.I. RTE.	SECTION	COUNTY	TOTAL SHEETS	SHEET NO.
290	13031.1, ETC., 3838RS-5	COOK	298	274
FED. ROAD DIST. NO.		ILLINOIS FED. AID PROJECT		
		CONTRACT NO. 60G52		

F.A. RTE.	SECTION	COUNTY	TOTAL SHEETS	SHEET NO.
STA.	TO STA.			
FED. ROAD DIST. NO.	ILLINOIS FED. AID PROJECT			

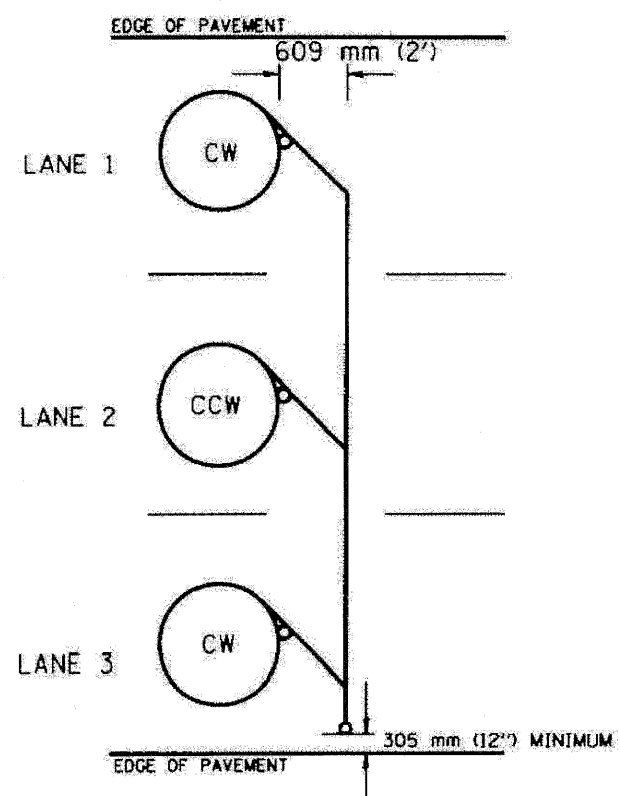

**TYPICAL 1.83 m (6FT.) DIA. INDUCTION LOOP CORE DRILL
LAYOUT FOR MULTIPLE LANE ROADWAY**

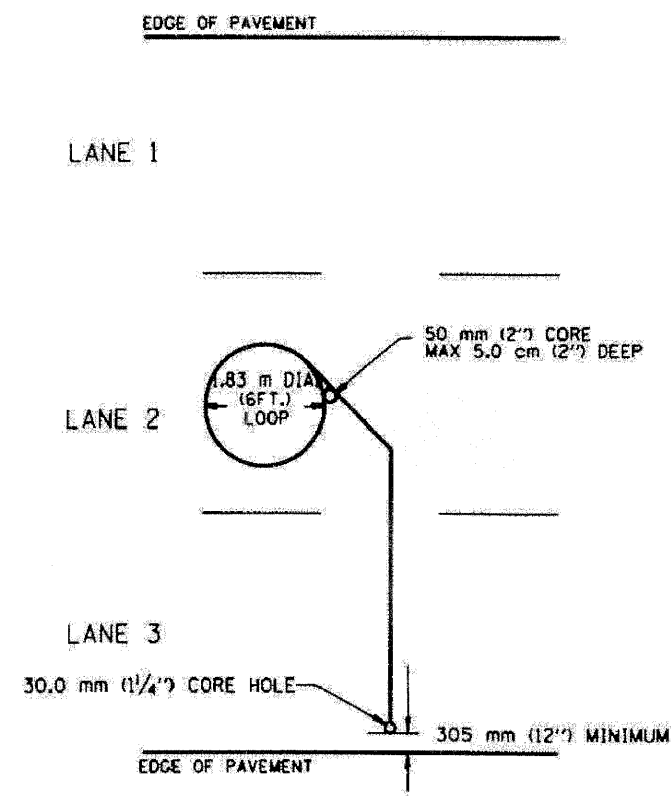

**TYPICAL 1.83 m (6') DIA. INDUCTION LOOP
LAYOUT FOR LANE 2**

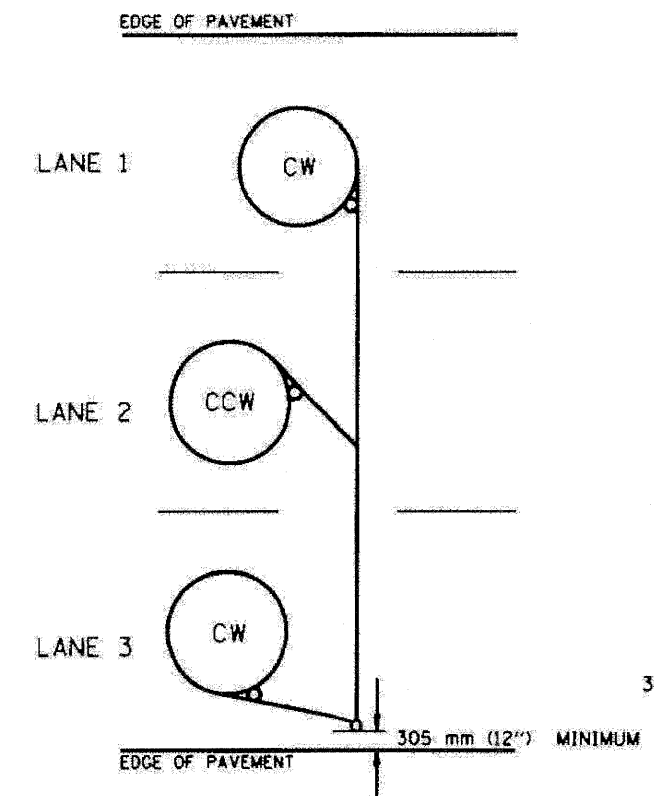

**TYPICAL 1.83 m (6') DIA. INDUCTION LOOP CORE DRILL
LAYOUT FOR MULTIPLE LANE ROADWAY**

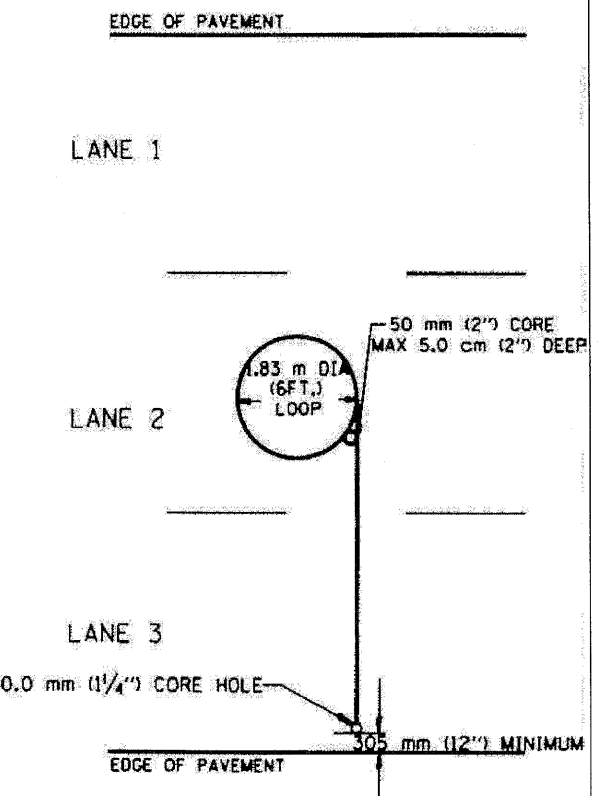

**TYPICAL 1.83 m (6') DIA. INDUCTION LOOP
LAYOUT FOR LANE 2**

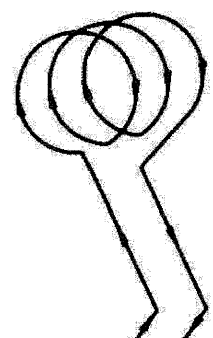

WIRING DETAILS

- NOTES**
1. EACH LOOP SHALL BE SPLICED TO A 4-C NO.18 TWISTED SHIELDED LEAD IN WHEN 45 m (150FT.) OR MORE FROM CABINET.
 2. LOOPS SHALL BE SPLICED IN HANDHOLES ONLY, OTHERWISE WRITTEN PERMISSION SHALL BE OBTAINED FROM TSC ENGINEER.
 3. LOOPS SHALL NOT BE SPLICED IN SERIES.
 4. EACH LOOP LEAD IN SHALL BE IDENTIFIED AND PERMANENTLY COLOR CODED IN THE COREHOLE, HANDHOLE & CABINETS THRU WHICH THEY ENTER OR PASS AND TAGGED WITH THE CORRECT NOMENCLATURES.

REVISIONS		ILLINOIS DEPARTMENT OF TRANSPORTATION TRAFFIC SYSTEMS CENTER EXISTING ROUND LOOP INSTALLATION	
NO.	DATE	SCALE	DATE

TRAFFIC SYSTEMS CENTER (TY-1TSC-418*1)

FILE NAME =	DESIGNED - GHT	REVISED -
...\\ppln-abc.c2.ts-det.09.wgn	DRAWN - TMB	REVISED -
USER NAME = tblank	CHECKED - MPM	REVISED -
PLOT DATE = 11/12/2009	DATE - 10/16/09	REVISED -

benesch

**STATE OF ILLINOIS
DEPARTMENT OF TRANSPORTATION**

TRAFFIC SYSTEMS CENTER DETAIL SHEETS	
SCALE: N.T.S.	SHEET NO. 9 OF 16 SHEETS
STA.	TO STA.

F.A.I. RTE.	SECTION	COUNTY	TOTAL SHEETS	SHEET NO.
290	(30311, ETC., 3838RS-5	COOK	298	276
FED. ROAD DIST. NO. ILLINOIS FED. AID PROJECT			CONTRACT NO. 60G52	

F.A. RTE.	SECTION	COUNTY	TOTAL SHEETS	SHEET NO.
STA.	TO STA.			
FED. ROAD DIST. NO.	ILLINOIS FED. AID PROJECT			

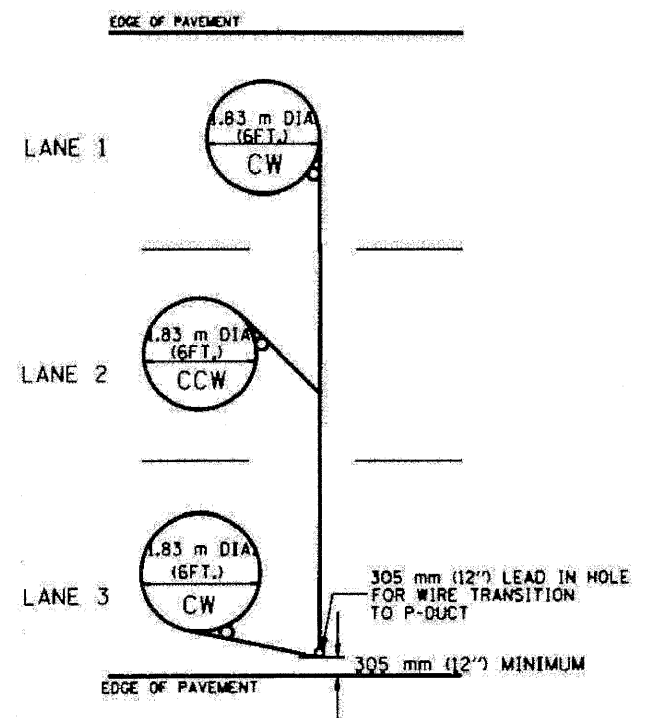

TYPICAL 1.83 m (6FT.) DIA. INDUCTION LOOP CORE DRILL LAYOUT FOR MULTIPLE LANE ROADWAY

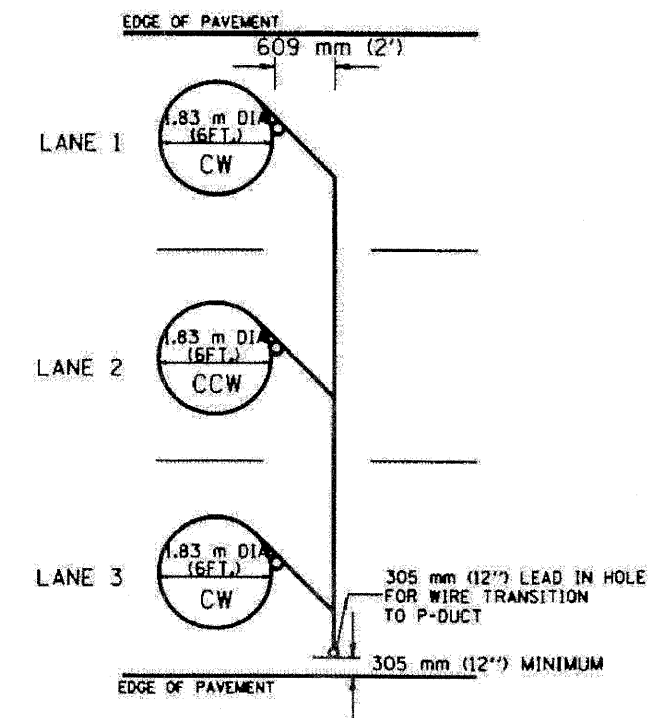

TYPICAL 1.83 m (6FT.) DIA. INDUCTION LOOP CORE DRILL LAYOUT FOR MULTIPLE LANE ROADWAY

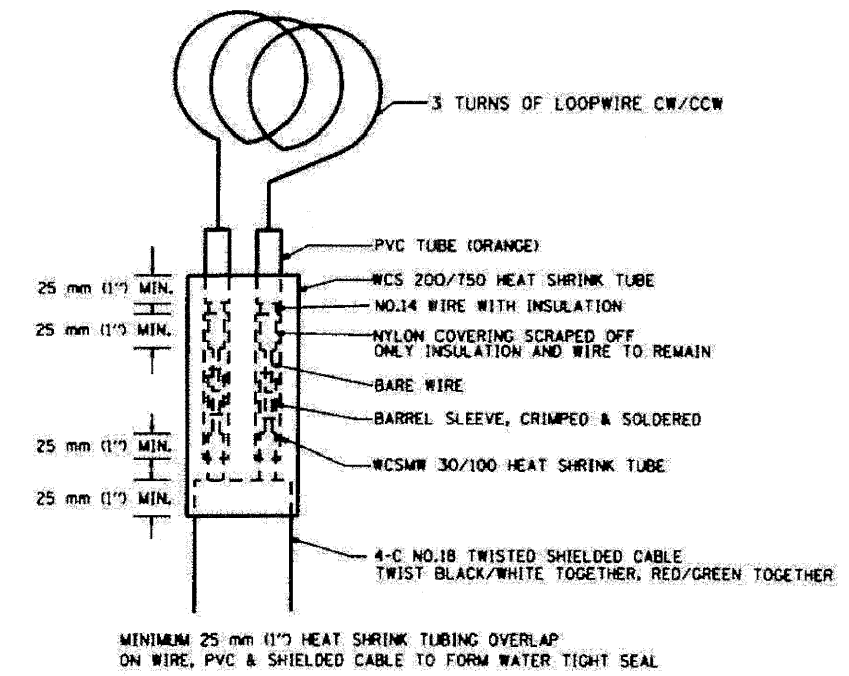
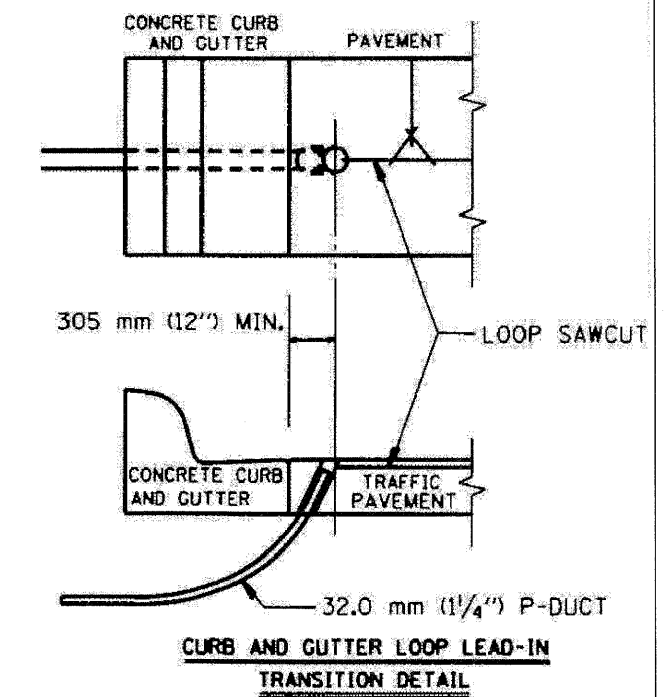

LOOP SPLICING REQUIREMENTS

- NOTES
1. EACH LOOP SHALL BE SPLICED TO A 4-C NO.18 TWISTED SHIELDED LEAD IN WHEN 45 m (150FT.) OR MORE FROM CABINET.
 2. LOOPS SHALL BE SPLICED IN HANDHOLES ONLY, OTHERWISE WRITTEN PERMISSION SHALL BE OBTAINED FROM TSC ENGINEER.
 3. LOOPS SHALL NOT BE SPLICED IN SERIES.
 4. EACH LOOP LEAD IN SHALL BE IDENTIFIED AND PERMANENTLY COLOR CODED IN THE COREHOLE, HANDHOLE & CABINETS THRU WHICH THEY ENTER OR PASS AND TAGGED WITH THE CORRECT NOMENCLATURES.

DESIGNED	GHT	REVISION	DATE	ILLINOIS DEPARTMENT OF TRANSPORTATION TRAFFIC SYSTEMS CENTER EXISTING ROUND INDUCTION LOOP TYPICALS SCALE: NONE DATE: 5-22-94 DRAWN BY: G.M. CHECKED BY: R.L.
DRAWN	TMB	REVISION	DATE	
CHECKED	MPM	REVISION	DATE	
DATE	10/16/09	REVISION	DATE	

TRAFFIC SYSTEMS CENTER (TY-1TSC-418#2)

FILE NAME	DESIGNED - GHT	REVISION	
\\prg\in\ABC\C2_TS_DET_10.dgn	DRAWN - TMB	REVISION	
USER NAME = tblank	CHECKED - MPM	REVISION	
PLOT DATE = 11/12/2009	DATE - 10/16/09	REVISION	

benesch

STATE OF ILLINOIS
DEPARTMENT OF TRANSPORTATION

SCALE: N.T.S.	SHEET NO. 10 OF 16 SHEETS	STA.	TO STA.
---------------	---------------------------	------	---------

F.A. RTE.	SECTION	COUNTY	TOTAL SHEETS	SHEET NO.
290	(3031.I, ETC., 3838)RS-5	COOK	298	277
FED. ROAD DIST. NO.			ILLINOIS FED. AID PROJECT	
			CONTRACT NO. 60G52	

F.A. RTE.	SECTION	COUNTY	TOTAL SHEETS	SHEET NO.
STA.	TO STA.			
FED. ROAD DIST. NO.	ILLINOIS FED. AID PROJECT			

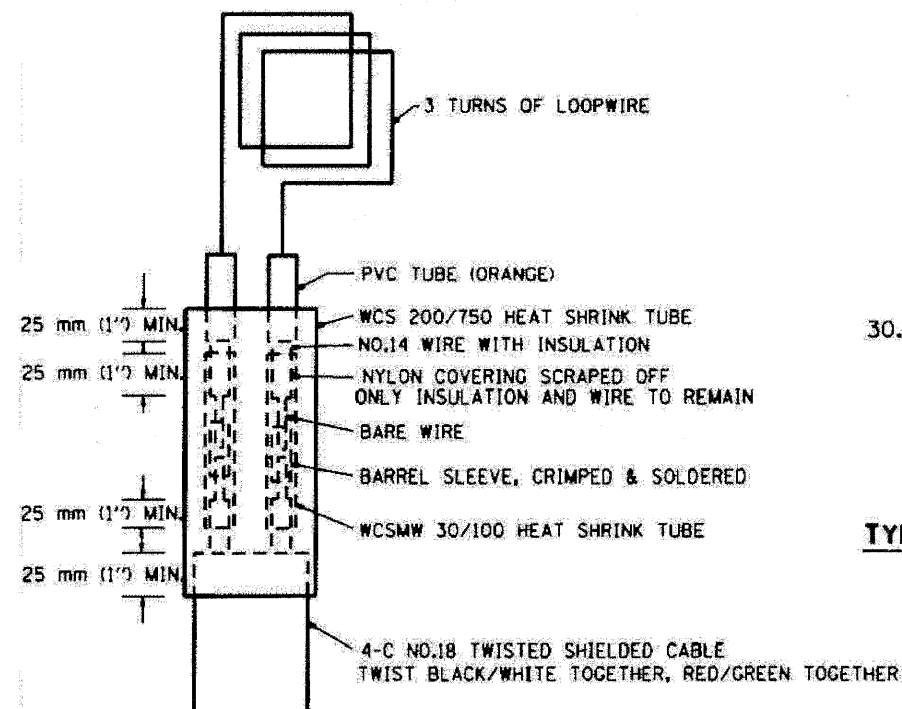

MINIMUM 25 mm (1") HEAT SHRINK TUBING OVERLAP ON WIRE, PVC & SHIELDED CABLE TO FORM WATER TIGHT SEAL

LOOP SPLICING REQUIREMENTS

WIDTH (W)	WIDTH (S)
3.7 m (12')	2.5 m (8')
4.0 m (13')	2.8 m (9')
4.3 m (14')	3.1 m (10')
4.6 m (15')	3.4 m (11')
4.9 m (16')	3.7 m (12')
5.2 m (17')	4.0 m (13')
5.5 m (18')	4.3 m (14')
5.8 m (19')	4.6 m (15')
6.1 m (20')	4.9 m (16')
6.4 m (21')	5.2 m (17')
6.7 m (22')	5.5 m (18')
7.0 m (23')	5.8 m (19')
7.3 m (24')	6.1 m (20')
7.6 m (25')	6.4 m (21')

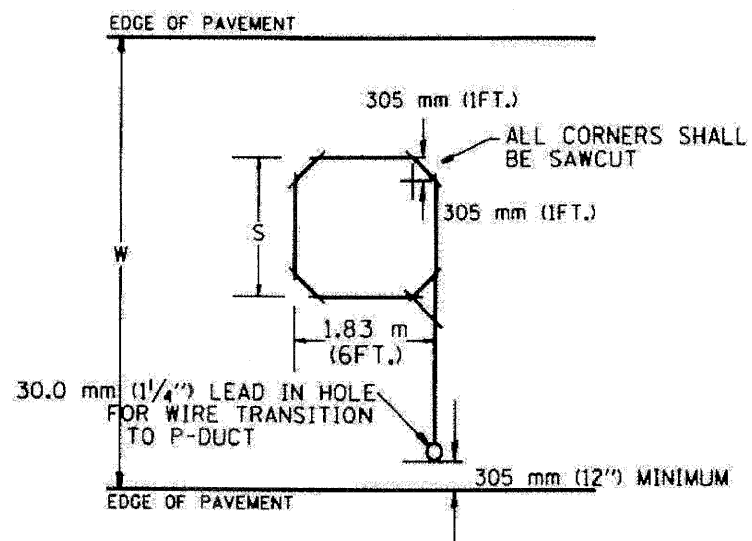

TYPICAL "S" FT. BY 1.83 m (6FT.) INDUCTION LOOP SAWCUT LAYOUT FOR RAMP

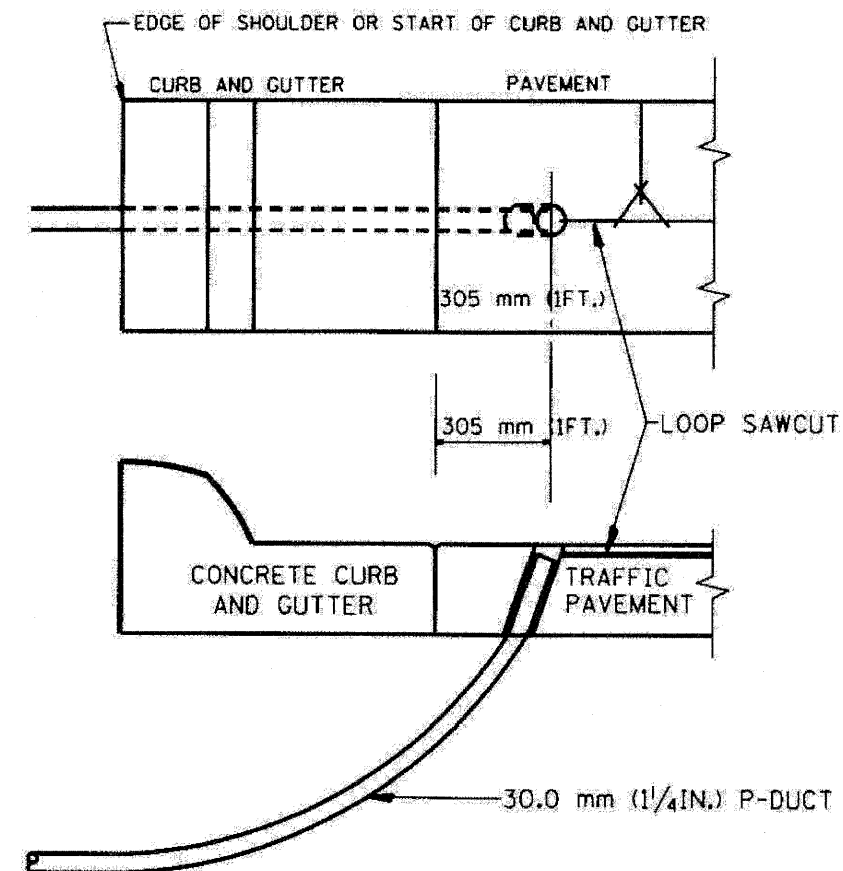

CURB AND GUTTER LOOP LEAD-IN TRANSITION DETAIL

NOTES

1. EACH LOOP SHALL BE SPLICED TO A 4-C NO.18 TWISTED SHIELDED LEAD IN WHEN 45 m (150FT.) OR MORE FROM CABINET.
2. LOOPS SHALL BE SPLICED IN HANDHOLES ONLY, OTHERWISE WRITTEN PERMISSION SHALL BE OBTAINED FROM TSC ENGINEER.
3. LOOPS SHALL NOT BE SPLICED IN SERIES.
4. EACH LOOP LEAD IN SHALL BE IDENTIFIED AND PERMANENTLY COLOR CODED IN THE COREHOLE, HANDHOLE & CABINETS THRU WHICH THEY ENTER OR PASS AND TAGGED WITH THE CORRECT NOMENCLATURES.

REVISED		ILLINOIS DEPARTMENT OF TRANSPORTATION TRAFFIC SYSTEMS CENTER
DATE	BY	
6/94	R.L.	RECTANGULAR INDUCTION LOOP TYPICAL
11/95	T.C.	
05/96	R.L.	
10/96	T.C.	
SCALE: VERT. NONE HORIZ. NONE		DATE 6-22-94
DRAWN BY: G.M.		CHECKED BY: R.L.

TRAFFIC SYSTEMS CENTER (TY-1TSC-418*3)

FILE NAME =	DESIGNED - GHT	REVISED -
...prpIn_ABC_C2_TS_DET_11.dgn	DRAWN - TMB	REVISED -
USER NAME = tblank	CHECKED - MPW	REVISED -
PLOT DATE = 11/12/2009	DATE - 10/16/09	REVISED -

benesch

**STATE OF ILLINOIS
DEPARTMENT OF TRANSPORTATION**

**TRAFFIC SYSTEMS CENTER
DETAIL SHEETS**

SCALE: N.T.S. SHEET NO. 11 OF 16 SHEETS STA. TO STA.

F.A. RTE.	SECTION	COUNTY	TOTAL SHEETS	SHEET NO.
290	(3031), ETC., 3838RS-5	COOK	298	278
FED. ROAD DIST. NO.			ILLINOIS FED. AID PROJECT	
			CONTRACT NO. 60652	

F.A. RTE.	SECTION	COUNTY	TOTAL SHEETS	SHEET NO.
STA.	TO STA.			
FED. ROAD DIST. NO.	ILLINOIS FED. AID PROJECT			

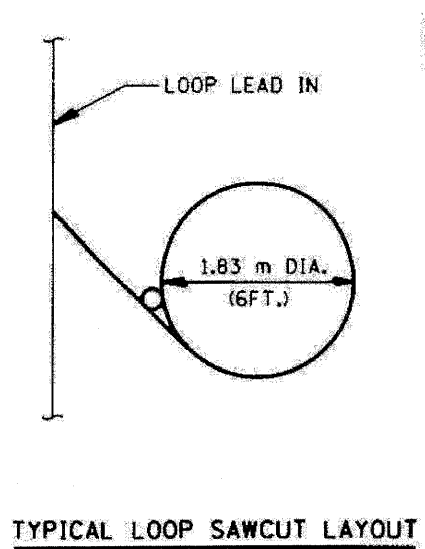

TYPICAL LOOP SAWCUT LAYOUT

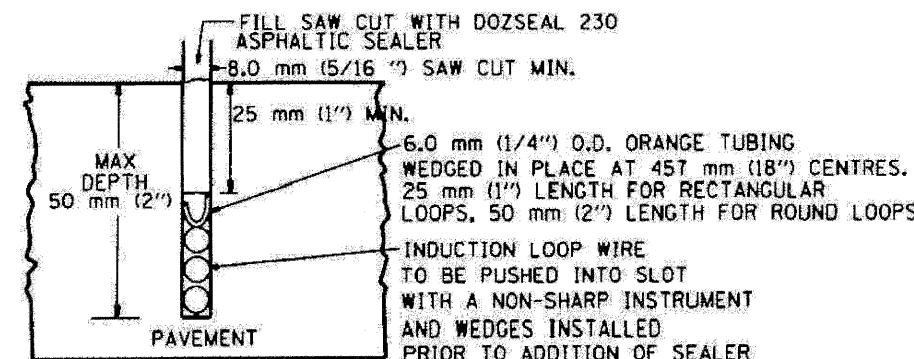
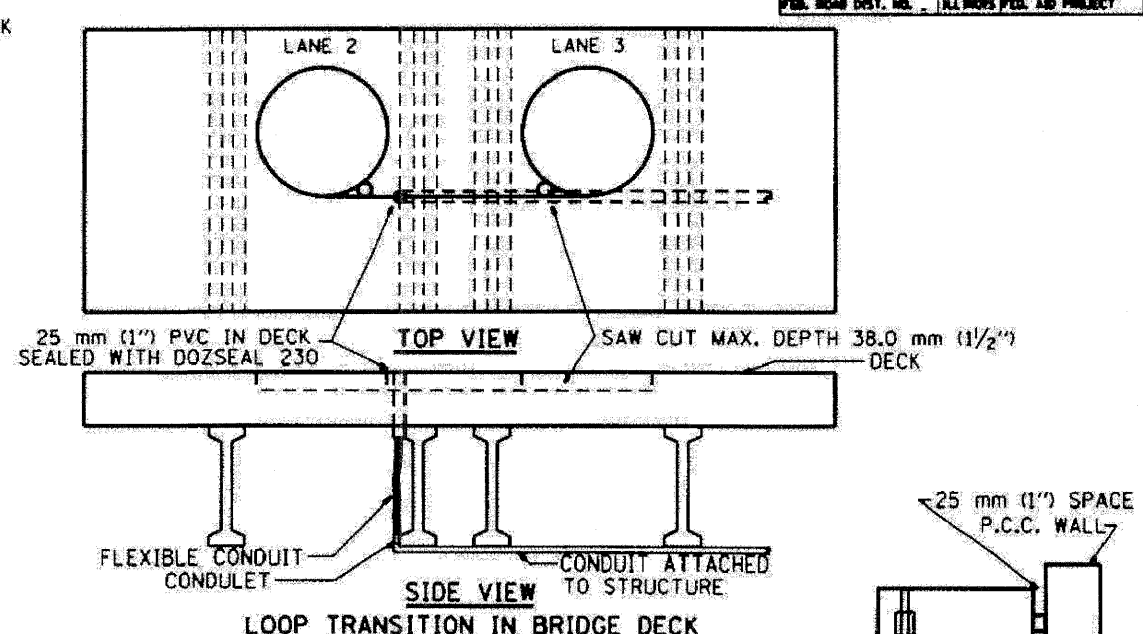
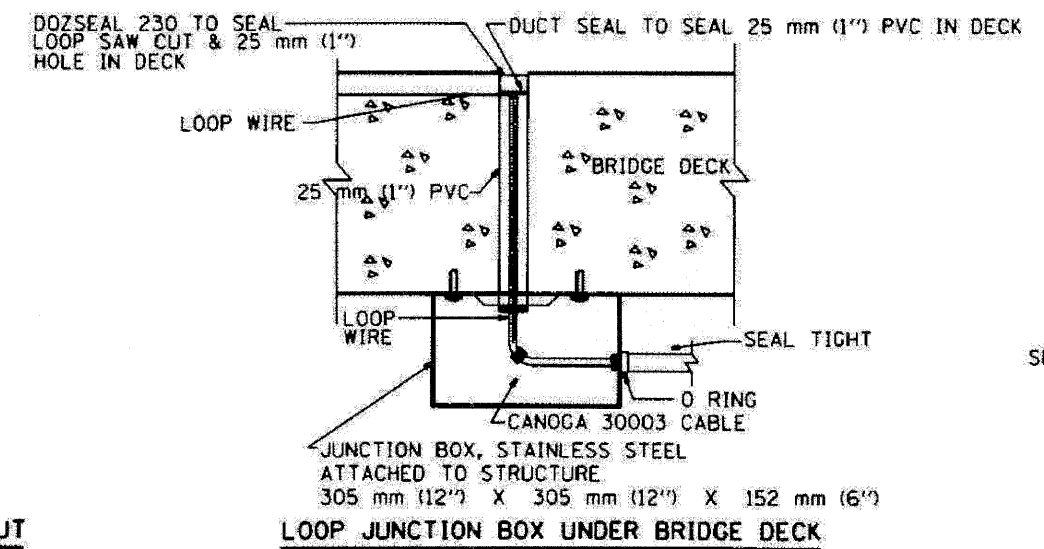

LOOP CROSS SECTION IN PAVEMENT

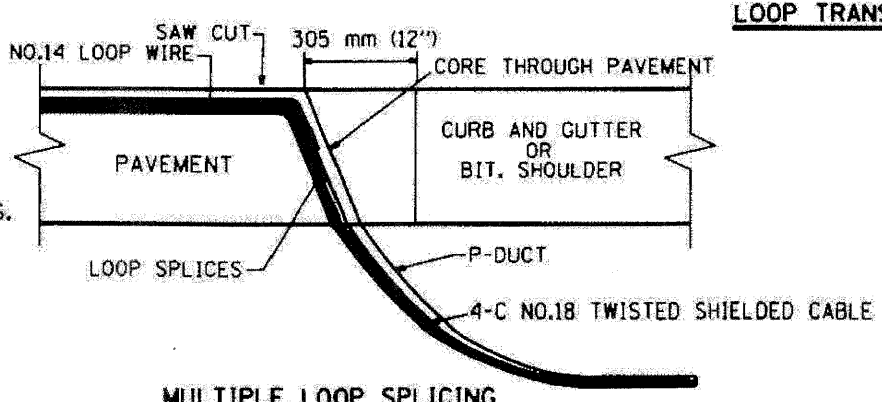

MULTIPLE LOOP SPlicing

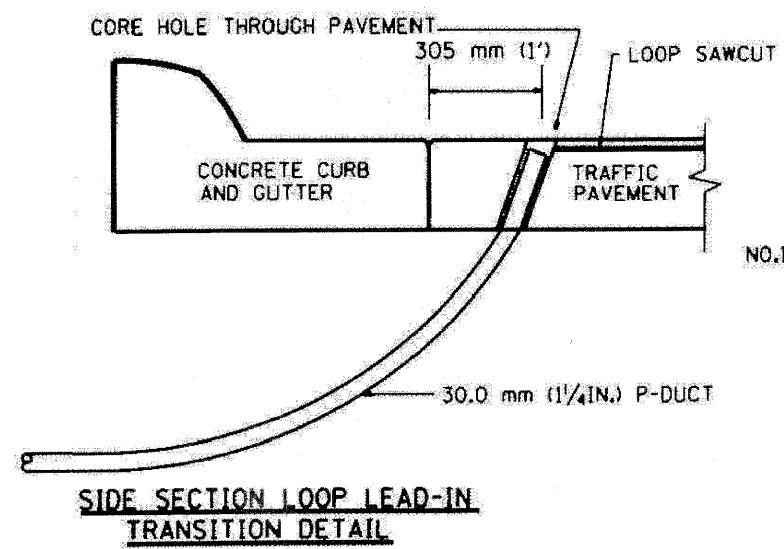

SIDE SECTION LOOP LEAD-IN TRANSITION DETAIL

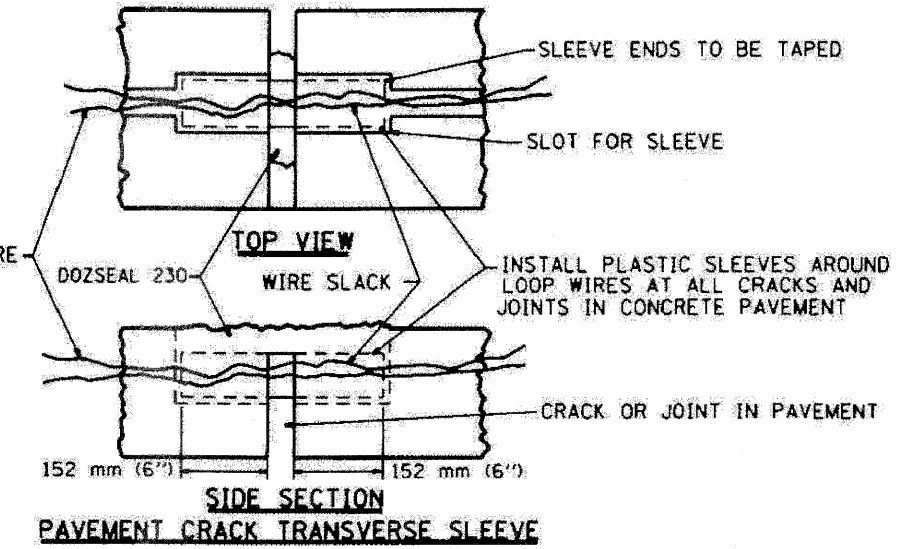

SIDE SECTION PAVEMENT CRACK TRANSVERSE SLEEVE

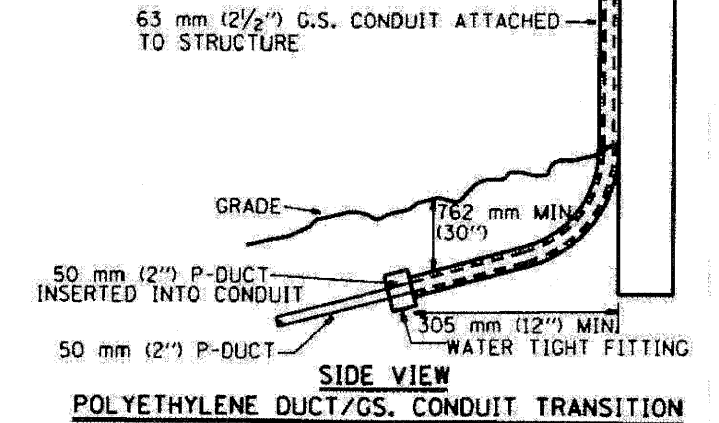

SIDE VIEW POLYETHYLENE DUCT/GS. CONDUIT TRANSITION

REVISIONS		DATE	ILLINOIS DEPARTMENT OF TRANSPORTATION TRAFFIC SYSTEMS CENTER
NO.	DESCRIPTION		
1.		5/78	LOOP, CONDUIT & DUCT INSTALLATION DETAILS SCALE: VERT. NONE DATE: 6-22-84 DRAWN BY: G.A. CHECKED BY: R.L.
2.		5/78	
3.		11/78	
4.		02/79	
5.		10/79	

TRAFFIC SYSTEMS CENTER (TY-1TSC-418*4)

FILE NAME =	DESIGNED - GHT	REVISED -
\\prip1n\arc_c2_ts_det_12.dgn	DRAWN - TMB	REVISED -
USER NAME = tblank	CHECKED - MPM	REVISED -
PLOT DATE = 11/12/2009	DATE - 10/16/09	REVISED -

benesch

STATE OF ILLINOIS
DEPARTMENT OF TRANSPORTATION

TRAFFIC SYSTEMS CENTER
DETAIL SHEETS

SCALE: N.T.S. SHEET NO. 12 OF 16 SHEETS STA. TO STA.

F.A. RTE.	SECTION	COUNTY	TOTAL SHEETS	SHEET NO.
290	(3031.1, ETC., 3838RS-5	COOK	298	279
FED. ROAD DIST. NO.			ILLINOIS FED. AID PROJECT	

F.A.I. RTE.	SECTION	COUNTY	TOTAL SHEETS	SHEET NO.
STA.	TO STA.			
FED. ROAD DIST. NO.	ILLINOIS FED. AID PROJECT			

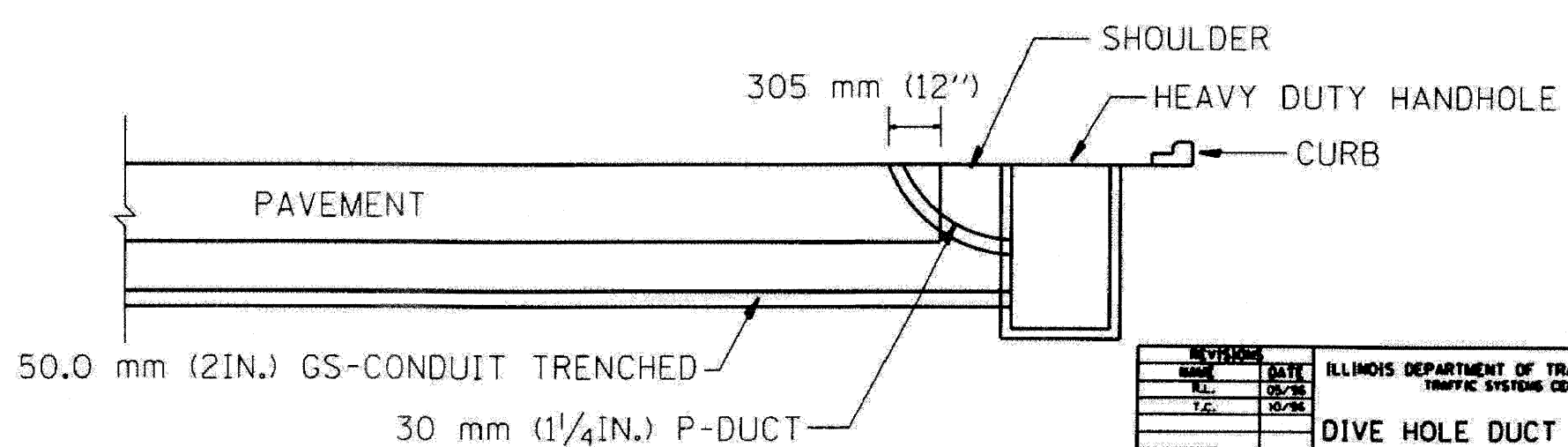
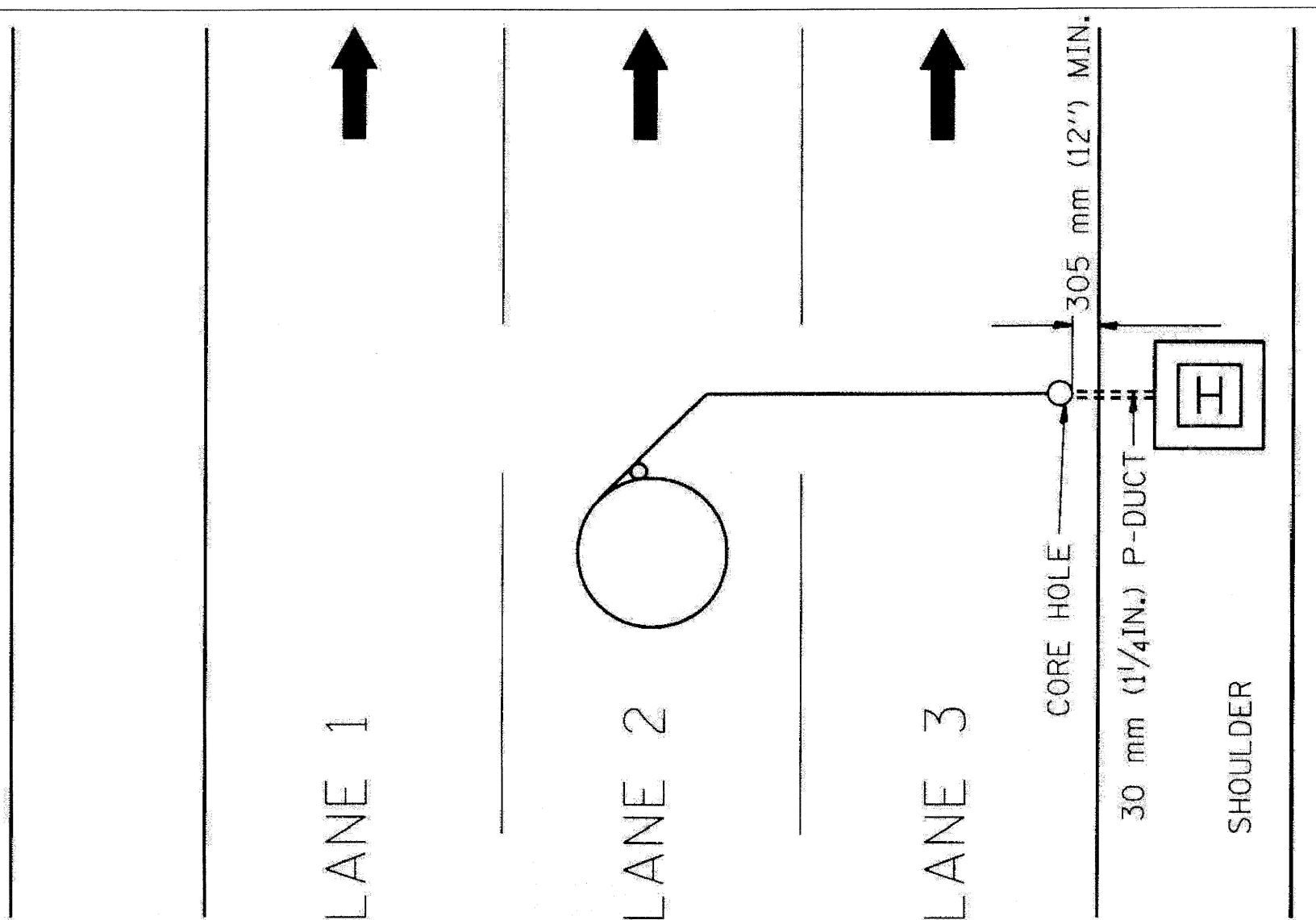

REVISIONS		ILLINOIS DEPARTMENT OF TRANSPORTATION TRAFFIC SYSTEMS CENTER	
NO.	DATE		
1.	05/98		
2.	10/98		

SCALE: NOT NONE
DATE: 11/7/98

DRAWN BY: G.M.
CHECKED BY: R.L.

TRAFFIC SYSTEMS CENTER (TY-1TSC-418#8)

FILE NAME =	DESIGNED - GHT	REVISED -
...prpIn_ABC.C2.TS.DET.13.dgn	DRAWN - TMB	REVISED -
USER NAME = tblank	CHECKED - MPW	REVISED -
PLOT DATE = 11/12/2009	DATE - 10/16/09	REVISED -

benesch

**STATE OF ILLINOIS
DEPARTMENT OF TRANSPORTATION**

**TRAFFIC SYSTEMS CENTER
DETAIL SHEETS**

SCALE: N.T.S. SHEET NO. 13 OF 16 SHEETS STA. TO STA.

F.A.I. RTE.	SECTION	COUNTY	TOTAL SHEETS	SHEET NO.
290	(3031.1, ETC., 3838)RS-5	COOK	298	280
FED. ROAD DIST. NO.	ILLINOIS FED. AID PROJECT			
			CONTRACT NO. 60052	

F.A.I. SITE	SECTION	COUNTY	TOTAL SHEETS	SHEET NO.
STA.	TO STA.			
FED. ROAD DIST. NO.	ILLINOIS FED. AID PROJECT			

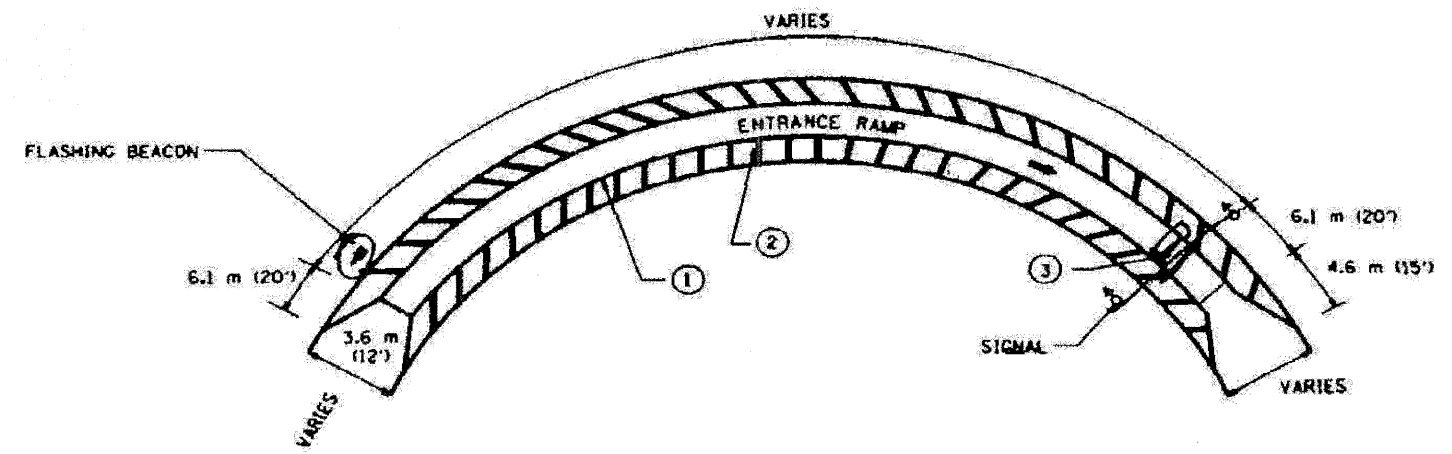
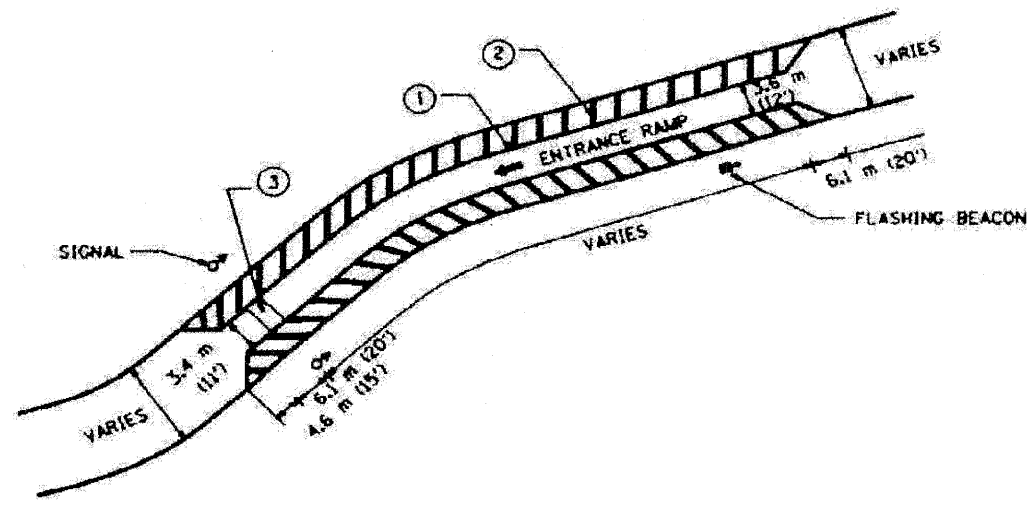

- PAVEMENT MARKING**
- ① 305 mm (12") WHITE CHANNEL MARKINGS
 - ② 203 mm (8") WHITE CROSS-HATCHING AT 3.05 m (10') INTERVALS
 - ③ 609 mm (24") WHITE STOP BAR CENTERED BETWEEN SIGNALS

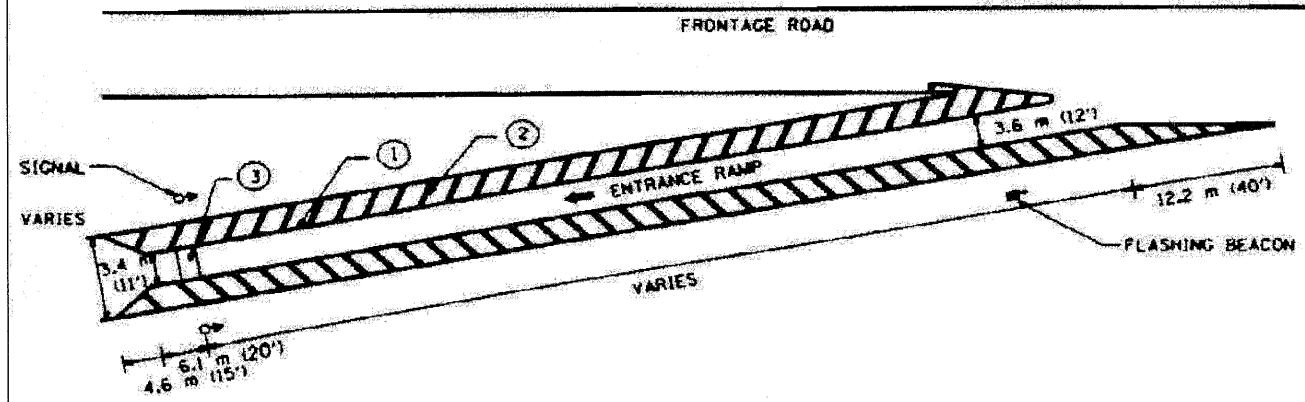

REVISIONS	
NO.	DATE

ILLINOIS DEPARTMENT OF TRANSPORTATION
 TRAFFIC SYSTEMS CENTER
**TYPICAL RAMP
 METERING STRIPING**
 SCALE: VERT. NONE
 DATE: 8-22-94
 DRAWN BY: C.M.
 CHECKED BY: R.L.

TRAFFIC SYSTEMS CENTER (TY-ITSC-500#1)

FILE NAME =	DESIGNED - GHT	REVISED -
w:\prp\in_abc\c2_ts_det_16.dgn	DRAWN - TMB	REVISED -
USER NAME = tblank	CHECKED - MPM	REVISED -
PILOT DATE = 11/12/2009	DATE - 10/16/09	REVISED -

benesch

**STATE OF ILLINOIS
 DEPARTMENT OF TRANSPORTATION**

TRAFFIC SYSTEMS CENTER DETAIL SHEETS	
SCALE: N.T.S.	SHEET NO. 15 OF 16 SHEETS
STA.	TO STA.

F.A.I. SITE	SECTION	COUNTY	TOTAL SHEETS	SHEET NO.
290	13031.J, ETC., 3838)RS-5	COOK	298	282
FED. ROAD DIST. NO.			ILLINOIS FED. AID PROJECT	
			CONTRACT NO. 60652	

LOOP DETECTOR NOTES

- EACH PAIR OF LOOP WIRES SHALL BE PLACED IN A SEPARATE EMPTY COILABLE NONMETALLIC CONDUIT FROM THE EDGE OF PAVEMENT TO THE HANDHOLE. SPACING BETWEEN THE HOLES DRILLED IN THE PAVEMENT SHALL NOT BE LESS THAN 6" (150 mm). EMPTY COILABLE NONMETALLIC CONDUIT SHALL BE INCLUDED IN THE COST OF THE LOOP WIRE.
- THE NUMBER OF LOOP TURNS SHALL BE AS RECOMMENDED BY THE AMPLIFIER MANUFACTURER. ALL ADJACENT SIDES OF THE LOOPS SHALL BE INSTALLED IN SUCH A WAY THAT THE CURRENT FLOW IS IN THE SAME DIRECTION TO REINFORCE ITS MAGNETIC FIELDS FOR SMALL VEHICLE DETECTION.
- EACH LOOP LEAD-IN SHALL BE IDENTIFIED AND PERMANENTLY TAGGED IN THE HANDHOLE. EACH LEAD-IN CABLE TAG SHALL INDICATE THE LOCATION OF THE LOOP, LOOP ROTATION (CLOCKWISE/COUNTERCLOCKWISE), LOOP LEAD-IN DIRECTION (IN OR OUT), LOOP CABLE NUMBER AND LOCATION IN CABINET, AND NUMBER OF TURNS IN THE DETECTOR LOOPS IN WATER PROOF INK AS INDICATED ON THE DISTRICT 1 STANDARD TRAFFIC SIGNAL DESIGN DETAIL. THE CONTRACTOR SHALL MARK LOOP LOCATIONS ON RECORD DRAWINGS AND PRESENT TO THE ENGINEER AFTER FINAL INSPECTION. LOOPS SHALL BE MARKED BY LANE AND LOOP NUMBER. SEE DETAIL BELOW.
- ALL LOOP CABLE SHALL BE FASTENED WITH PLASTIC TIE WRAP TO THE HANDHOLE HOOKS.
- IN ASPHALT PAVEMENT, LOOPS SHOULD BE PLACED IN THE BINDER AND DIVEHOLES MARKED AT THE CURB WITH A SAW-CUT. THE SAW-CUT SHALL BE CUT IN ACCORDANCE WITH LOCAL AND E.P.A. DUST CONTROL REQUIREMENTS. DETECTOR LOOP(S) SHALL NOT BE INSTALLED IN WET CONDITIONS AND THE SAW-CUTS MUST BE FREE OF DEBRIS AND RESIDUE SUCH AS DUST AND WATER WHICH IS TO BE ACHIEVED BY THE USE OF COMPRESSED AIR, WIRE BRUSHING AND HEAT DRYING ACCORDING TO SEALANT MANUFACTURER REQUIREMENTS. THE DETECTOR WIRE SHALL BE HELD IN PLACE BY THE USE OF FORM WEDGES. WEDGES SHALL BE SPACED NO MORE THAN 18" (450 mm) APART.
- LOOP SPLICES SHALL BE SOLDERED USING A SOLDERING IRON. BLOW TORCHES OR OTHER DEVICES WHICH OXIDIZE COPPER CABLE SHALL NOT BE ALLOWED FOR SOLDERING OPERATIONS. SEE DETAIL BELOW RIGHT.
- PREFORMED DETECTOR LOOPS SHALL BE USED, AS SHOWN ON THE PLANS, WHERE NEW CONCRETE PAVEMENT IS PROPOSED. THE INSTALLATION OF PREFORMED LOOPS SHALL BE IN ACCORDANCE WITH THE DISTRICT 1 SPECIFICATIONS OR AS DIRECTED BY THE ENGINEER.

LOOP LEAD-IN CABLE TAG

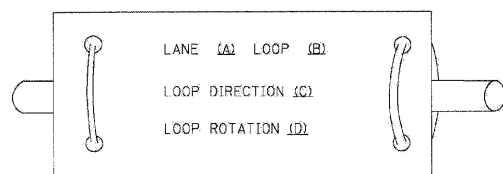

- LANE 1 IS THE LANE CLOSEST TO THE CENTERLINE OF THE ROADWAY
- LOOP #1 IS THE LOOP IN THE LANE CLOSEST TO THE INTERSECTION.
- LABEL LOOP CABLE "IN" OR LOOP CABLE "OUT".
- LABEL LOOP CABLE CLOCKWISE OR LOOP CABLE COUNTERCLOCKWISE.

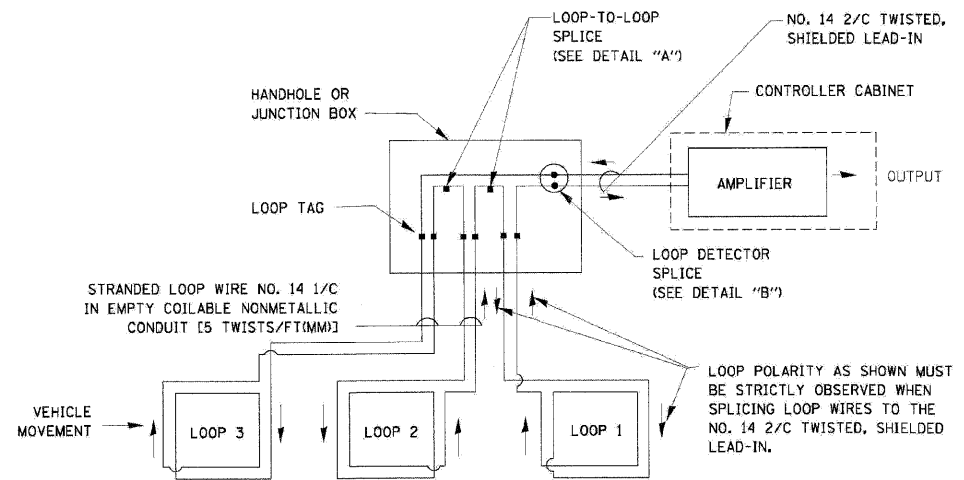

DETECTOR LOOP WIRING SCHEMATIC

- LOOPS SHALL BE SPLICED IN SERIES.
- SAW-CUTS SHALL BE A MINIMUM WIDTH OF 5/16" (8 mm).
- SAW-CUT DEPTHS SHALL BE 3" (75 mm). IF IN CONCRETE, THE SAW-CUT DEPTH SHALL BE TO THE TOP OF THE REINFORCEMENT.
- LOOP CORNERS SHALL BE DRILLED WITH A 2" (50 mm) DIAMETER CORE.

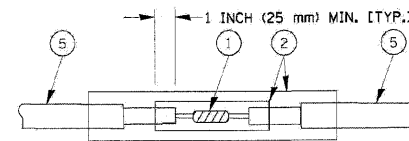

**DETAIL "A"
LOOP-TO-LOOP SPLICE**

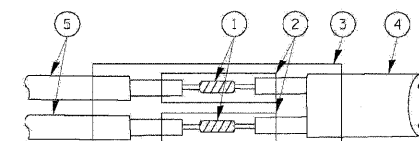

**DETAIL "B"
LOOP-TO-CONTROLLER SPLICE**

TYPE I LOOP

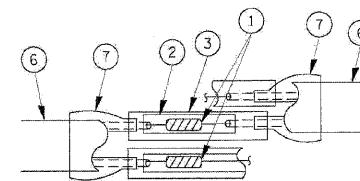

**DETAIL "A"
LOOP-TO-LOOP SPLICE**

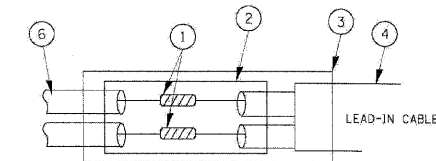

**DETAIL "B"
LOOP-TO-CONTROLLER SPLICE**

LOOP DETECTOR SPLICE

- WESTERN UNION SPLICE SOLDERED WITH ROSIN CORE FLUX. ALL EXPOSED SURFACES OF THE SOLDER SHALL BE SMOOTH.
- WCSMW 30/100 HEAT SHRINK TUBE, MINIMUM LENGTH 3" (75 mm), UNDERWATER GRADE.
- WCS 200/750 HEAT SHRINK TUBE, MINIMUM LENGTH 6" (150 mm), UNDERWATER GRADE.
- NO. 14 2/C TWISTED, SHIELDED CABLE.
- LOOP CONDUCTOR WITH FLEXIBLE PLASTIC TUBE.
- PREFORMED LOOP
- XL POLYOLEFIN 2 CONDUCTOR BREAKOUT SEALS, TYCO CBR-2 OR APPROVED EQUAL

FILE NAME =	USER NAME =	DESIGNED - DAD	REVISED -	STATE OF ILLINOIS DEPARTMENT OF TRANSPORTATION	DISTRICT ONE STANDARD TRAFFIC SIGNAL DESIGN DETAILS	F.A.I. RTE.	SECTION	COUNTY	TOTAL SHEETS	SHEET NO.	
...	...	DRAWN - BCK	REVISED -			SCALE:	SHEET NO. 1 OF 6 SHEETS	STA.	TO STA.	FED. ROAD DIST. NO.	ILLINOIS FED. AID PROJECT
		CHECKED - DAD	REVISED -			CONTRACT NO.					
		DATE - 10/28/09	REVISED -								

FILE NAME =	DESIGNED - GHT	REVISED -	benesch	STATE OF ILLINOIS DEPARTMENT OF TRANSPORTATION	DISTRICT ONE - DETECTOR LOOP REPLACEMENT I-290 (CENTER RAMPS) @ ILL RTE 43	F.A.I. RTE.	SECTION	COUNTY	TOTAL SHEETS	SHEET NO.	
...	DRAWN - TMB	REVISED -				SCALE: N.T.S.	SHEET NO. OF SHEETS	STA.	TO STA.	FED. ROAD DIST. NO.	ILLINOIS FED. AID PROJECT
USER NAME =	CHECKED - MPM	REVISED -				CONTRACT NO. 60652					
PLOT DATE = 11/13/2009	DATE - 10/16/09	REVISED -									

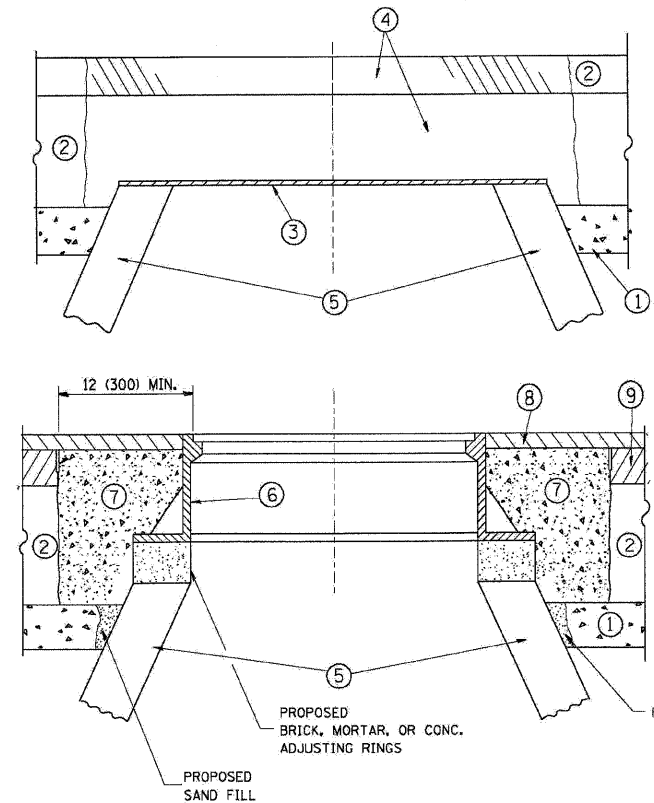

CONSTRUCTION PROCEDURES

STAGE 1 (BEFORE PAVEMENT MILLING)

- A) REMOVE A MINIMUM OF 12 (300) OF THE PAVEMENT FROM AROUND THE STRUCTURE.
- B) REMOVE THE EXISTING FRAME AND LID FROM THE STRUCTURE.
- C) COVER THE STRUCTURE OPENING WITH A 36 (900) DIAMETER METAL PLATE.
- D) BACKFILL WITH CRUSHED STONE AND A MINIMUM 1/2 (40) THICK HMA SURFACE MIX APPROVED BY THE ENGINEER.

STAGE 2 (AFTER PAVEMENT MILLING)

- A) REMOVE THE HMA SURFACE MIX AND CRUSHED STONE.
- B) INSTALL THE FRAME AND LID; ADJUST THE FRAME TO ITS FINAL SURFACE ELEVATION.
- C) THE SURROUNDING SPACE SHALL BE FILLED WITH CLASS SI CONCRETE, OR HMA SURFACE COURSE OR HMA BINDER COURSE TO THE ELEVATION OF THE SURFACE OF THE EXISTING BASE COURSE OR THE BINDER COURSE.

THE PROCEDURE EXPLAINED ABOVE SHALL CONFORM TO THE APPLICABLE PORTIONS OF SECTIONS 353, 406, 602, AND 603 OF THE STANDARD SPECIFICATIONS.

LEGEND

- ① SUB-BASE GRANULAR MATERIAL
- ② EXISTING PAVEMENT
- ③ 36 (900) DIAMETER METAL PLATE
- ④ PROPOSED CRUSHED STONE AND HMA SURFACE MIX
- ⑤ EXISTING STRUCTURE
- ⑥ FRAME AND LID (SEE NOTES)
- ⑦ CLASS SI CONCRETE, HMA SURFACE COURSE OR HMA BINDER COURSE
- ⑧ PROPOSED HMA SURFACE COURSE
- ⑨ PROPOSED HMA BINDER COURSE

NOTES:

EXISTING BROKEN FRAMES AND LIDS SHALL BE REMOVED AND DISPOSED OF BY THE CONTRACTOR AND SHALL BE REPLACED AS DIRECTED BY THE ENGINEER. REPLACEMENT FRAMES AND LIDS WILL BE PAID FOR IN ACCORDANCE WITH ARTICLE 109.04 OF THE STANDARD SPECIFICATIONS UNLESS A SEPARATE PAY ITEM HAS BEEN PROVIDED.

IF THE EXISTING LIDS ARE OPEN, THE FRAME WILL BE ADJUSTED TO THE ELEVATION OF THE MILLED PAVEMENT SURFACE PRIOR TO THE MILLING OPERATION. THE FRAME WILL NOT BE REMOVED AND COVERED BY THE METAL PLATE.

CITY OF CHICAGO CASTINGS ARE THE PROPERTY OF THE CITY AND THE CONTRACTOR SHALL NOTIFY THE CITY FOR REMOVAL AND DISPOSITION OF THE CASTINGS.

THE METAL PLATE USED TO COVER THE STRUCTURE SHALL REMAIN THE PROPERTY OF THE CONTRACTOR.

WHEN STRUCTURES ARE TO BE ADJUSTED OR RECONSTRUCTED, THE LOWERING AND RAISING OF THE FRAMES AND LIDS WILL NOT BE PAID FOR SEPARATELY BUT WILL BE INCLUDED IN THE COST OF THE CORRESPONDING PAY ITEM.

LOCATION OF STRUCTURES:

THE CONTRACTOR WILL BE REQUIRED TO KEEP A RECORD OF THE LOCATIONS OF THE BURIED STRUCTURES ACCORDING TO THE STATION AND DISTANCE LEFT OR RIGHT OF THE CENTERLINE OF PAVEMENT. UPON COMPLETION OF THE WORK, THE CONTRACTOR WILL DELIVER THE RECORD TO THE ENGINEER.

BASIS OF PAYMENT: THIS WORK WILL BE PAID FOR AT THE CONTRACT UNIT PRICE PER EACH FOR "FRAMES AND LIDS TO BE ADJUSTED, SPECIAL" NEW FRAMES AND LIDS, WHEN SPECIFIED, WILL BE PAID FOR SEPARATELY.

DETAILS FOR FRAMES AND LIDS ADJUSTMENT WITH MILLING

BD-08

ALL DIMENSIONS ARE IN INCHES (MILLIMETERS) UNLESS OTHERWISE SHOWN

FILE NAME =	DESIGNED - AJP	REVISED -
...\\corp\in_abc_c2_01_80-8.dgn	DRAWN - TMB	REVISED -
USER NAME = colank	CHECKED - JMM	REVISED -
PLOT DATE = 11/12/2009	DATE - 10/16/09	REVISED -

benesch

**STATE OF ILLINOIS
DEPARTMENT OF TRANSPORTATION**

FRAMES AND LIDS ADJUSTMENT WITH MILLING

SCALE: N.T.S. SHEET NO. 1 OF 15 SHEETS STA. TO STA.

F.A.I. RTE.	SECTION	COUNTY	TOTAL SHEETS	SHEET NO.
290	(3031.I, ETC., 383B/RS-5	COOK	298	284
FED. ROAD DIST. NO.			ILLINOIS FED. AID PROJECT	
			CONTRACT NO. 60652	

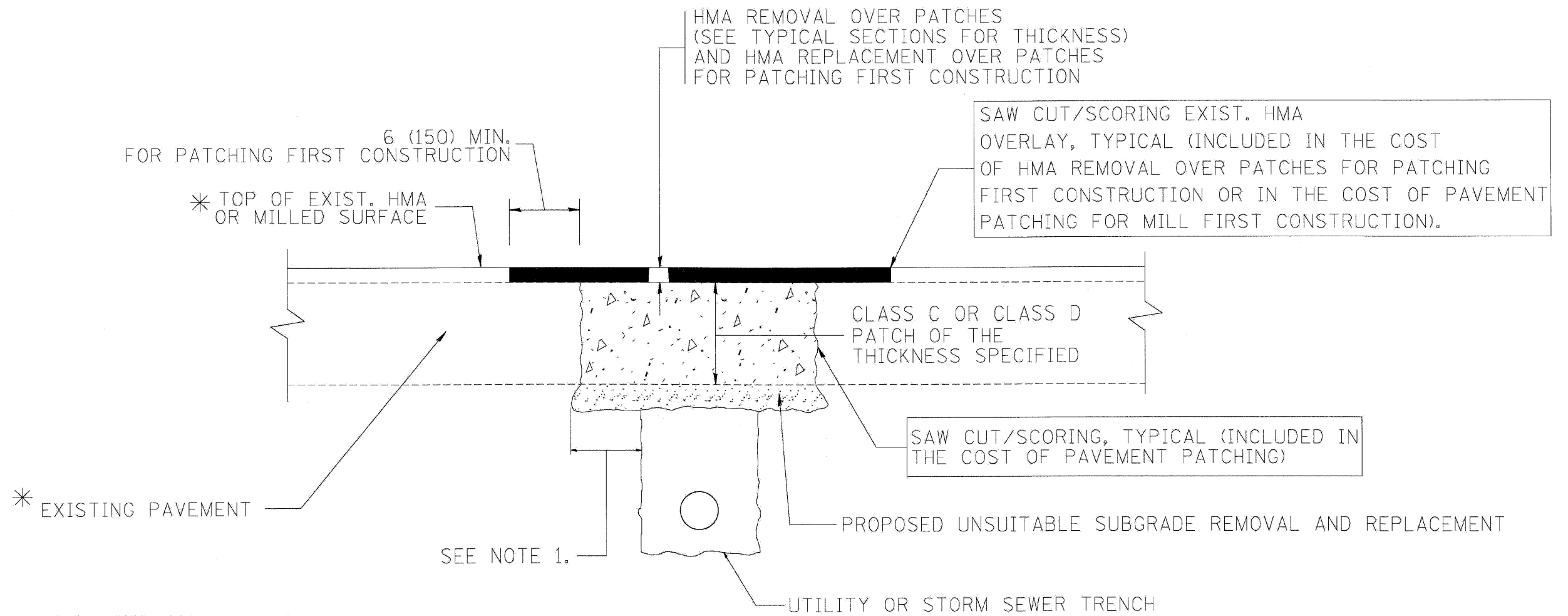

* SEE TYPICAL SECTIONS FOR THICKNESS AND MATERIALS

NOTES:

1. THE WIDTH OF THE FULL DEPTH PATCH OVER A TRENCH SHALL BE 12 (300) WIDER ON EACH SIDE OF THE TRENCH.
2. FOR METHOD OF MEASUREMENT AND BASIS OF PAYMENT, SEE RECURRING SPECIAL PROVISION "PATCHING WITH HOT-MIX ASPHALT OVERLAY REMOVAL".

SEQUENCE OF CONSTRUCTION (PATCHING FIRST)

1. REMOVE THE EXISTING HMA MATERIAL OVER THE AREA TO BE PATCHED.
2. REMOVE AND REPLACE WITH CLASS C OR D PATCH.
3. REPLACE HMA MATERIAL OVER THE AREA TO BE PATCHED.

SEQUENCE OF CONSTRUCTION (MILLING FIRST)

1. MILL HMA FIRST IF THERE IS AT LEAST 4 1/2 INCHES OR MORE OF HMA MATERIAL ON TOP OF THE EXISTING PAVEMENT OR IF THE PAVEMENT IS FULL DEPTH HMA. A MINIMUM OF 2 INCHES OF HMA MATERIAL SHALL BE IN PLACE AFTER MILLING.
2. REMOVE AND REPLACE WITH FULL DEPTH CLASS D PATCHES TO TOP OF MILLED SURFACE.

BD-22

ALL DIMENSIONS ARE IN INCHES (MILLIMETERS) UNLESS OTHERWISE SHOWN.

FILE NAME =	DESIGNED - AJP	REVISED -
...prpIn_ABC_C2_01_80-22.dgn	DRAWN - TMB	REVISED -
USER NAME = tblank	CHECKED - JMM	REVISED -
PLOT DATE = 11/12/2009	DATE - 10/16/09	REVISED -

benesch

**STATE OF ILLINOIS
DEPARTMENT OF TRANSPORTATION**

PAVEMENT PATCHING FOR HMA SURFACED PAVEMENT

SCALE: N.T.S. SHEET NO. 2 OF 15 SHEETS STA. TO STA.

F.A.I. RTE.	SECTION	COUNTY	TOTAL SHEETS	SHEET NO.
290	(3031.1, ETC., 3838)RS-5	COOK	298	285
FED. ROAD DIST. NO. ILLINOIS FED. AID PROJECT			CONTRACT NO. 60G52	

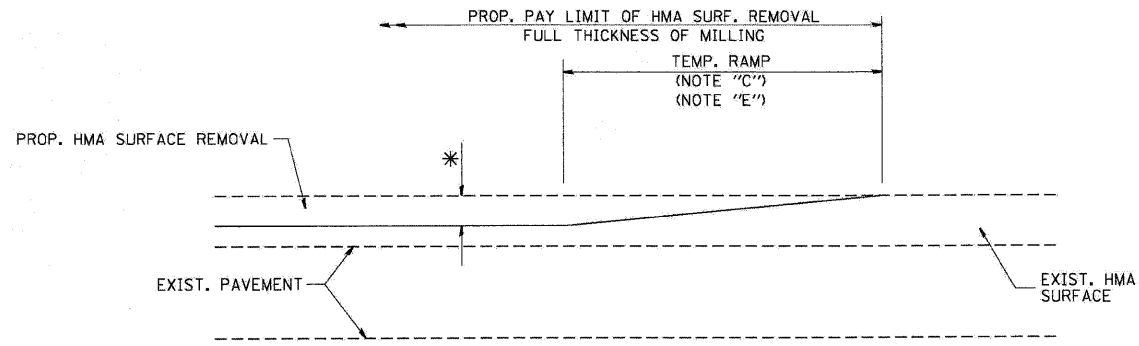

MILLED TEMPORARY RAMP
(FOR BUTT JOINT AND HMA TAPER SEE DETAIL BELOW)

OPTION 1

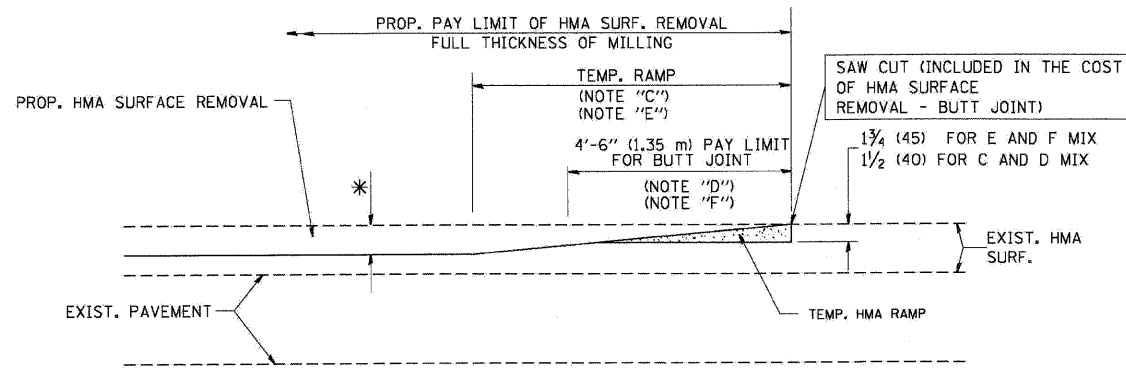

HMA CONSTRUCTED TEMPORARY RAMP
(FOR BUTT JOINT AND HMA TAPER SEE DETAIL BELOW)

OPTION 2
TYPICAL TEMPORARY RAMP

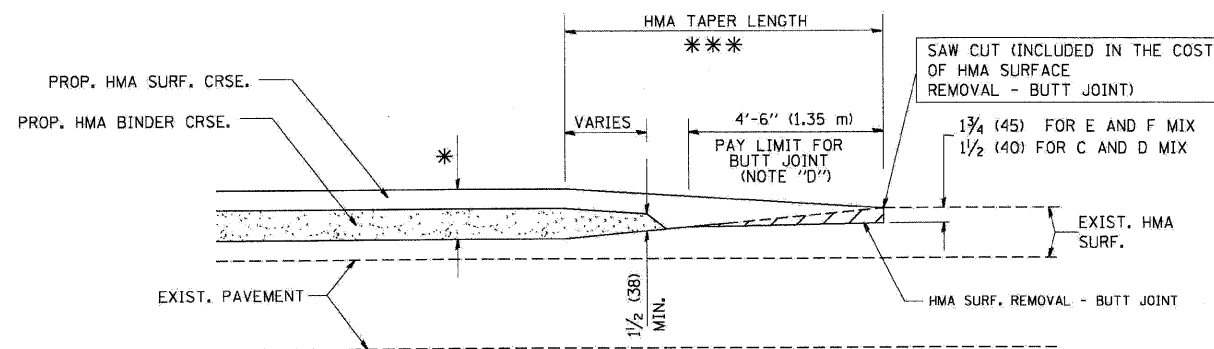

BUTT JOINT AND HMA TAPER
TYPICAL BUTT JOINT AND HMA TAPER FOR MILLING AND RESURFACING

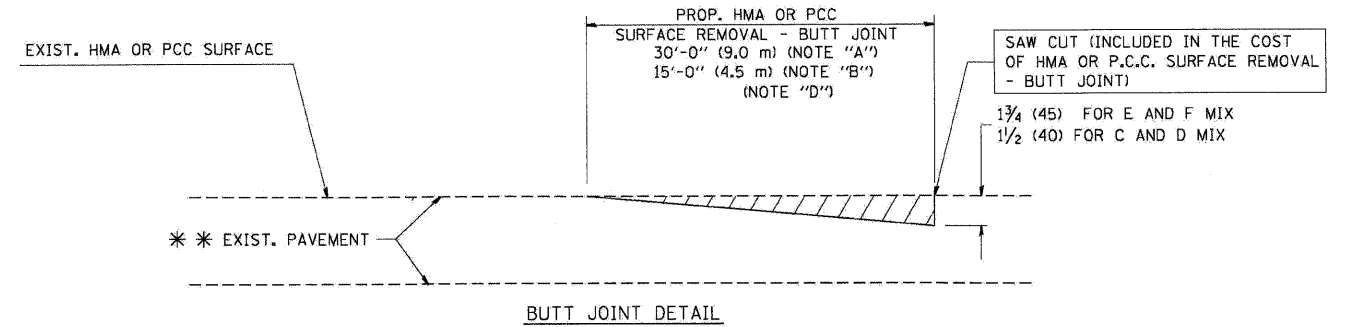

BUTT JOINT DETAIL

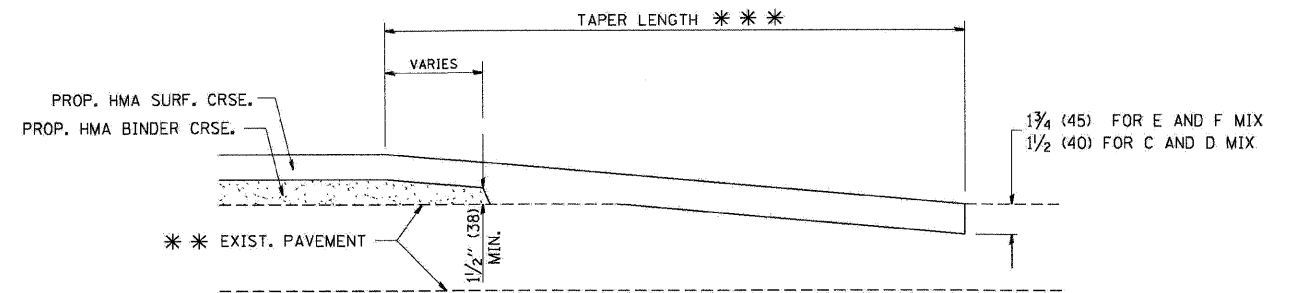

HMA TAPER DETAIL

TYPICAL BUTT JOINT AND HMA TAPER FOR RESURFACING ONLY

* * * PC CONCRETE, HMA OR HMA RESURFACED PAVEMENT.

NOTES

- A: MAINLINE ROADWAYS AND MAJOR SIDE ROADS.
- B: MINOR SIDE ROADS.
- C: THE TEMP. RAMP SHALL BE CONSTRUCTED IMMEDIATELY UPON REMOVAL OF THE EXISTING HMA SURFACE.
- D: THE BUTT JOINT SHALL BE CONSTRUCTED IMMEDIATELY PRIOR TO PLACING THE PROPOSED HMA COURSES.
- E: TAPER THE TEMP. RAMP AT A RATE OF 3'-0" (900 mm) PER 1 INCH (25 mm) OF MILLING THICKNESS.
- F: INSTALLATION AND REMOVAL OF THE 4'-6" (1.35 m) TEMP. RAMP IS INCLUDED IN COST OF HMA SURFACE REMOVAL - BUTT JOINT
- G: SEE ARTICLE 406.08 AND 406.14 OF THE STANDARD SPECIFICATIONS FOR "HMA AND/OR PCC SURFACE REMOVAL, BUTT JOINT".
- * SEE TYPICAL SECTIONS FOR MILLING THICKNESS.
- * * * 20'-0" (6.1 m) PER 1 (25) RESURFACING (NOTE "A")
10'-0" (3.0 m) PER 1 (25) RESURFACING (NOTE "B")

BASIS OF PAYMENT:

THE BUTT JOINT WILL BE PAID FOR AT THE CONTRACT UNIT PRICE PER SQUARE YARD (SQUARE METER) FOR "HOT-MIX ASPHALT SURFACE REMOVAL - BUTT JOINT" OR FOR "PORTLAND CEMENT CONCRETE SURFACE REMOVAL - BUTT JOINT".

BD-32

ALL DIMENSIONS ARE IN INCHES (MILLIMETERS) UNLESS OTHERWISE SHOWN.

FILE NAME =	DESIGNED - AJP	REVISED -
...\\ppp\in\ARC_C2_JL_80-32.dgn	DRAWN - TMB	REVISED -
USER NAME = tblank	CHECKED - JMM	REVISED -
PLOT DATE = 11/12/2009	DATE - 10/16/09	REVISED -

benesch

**STATE OF ILLINOIS
DEPARTMENT OF TRANSPORTATION**

BUTT JOINTS AND HMA TAPER

SCALE: N.T.S. SHEET NO. 3 OF 15 SHEETS STA. TO STA.

F.A.I. RTE.	SECTION	COUNTY	TOTAL SHEETS	SHEET NO.
290	(3031.1, ETC., 3838)RS-5	COOK	298	286
FED. ROAD DIST. NO. ILLINOIS FED. AID PROJECT			CONTRACT NO. 60G52	

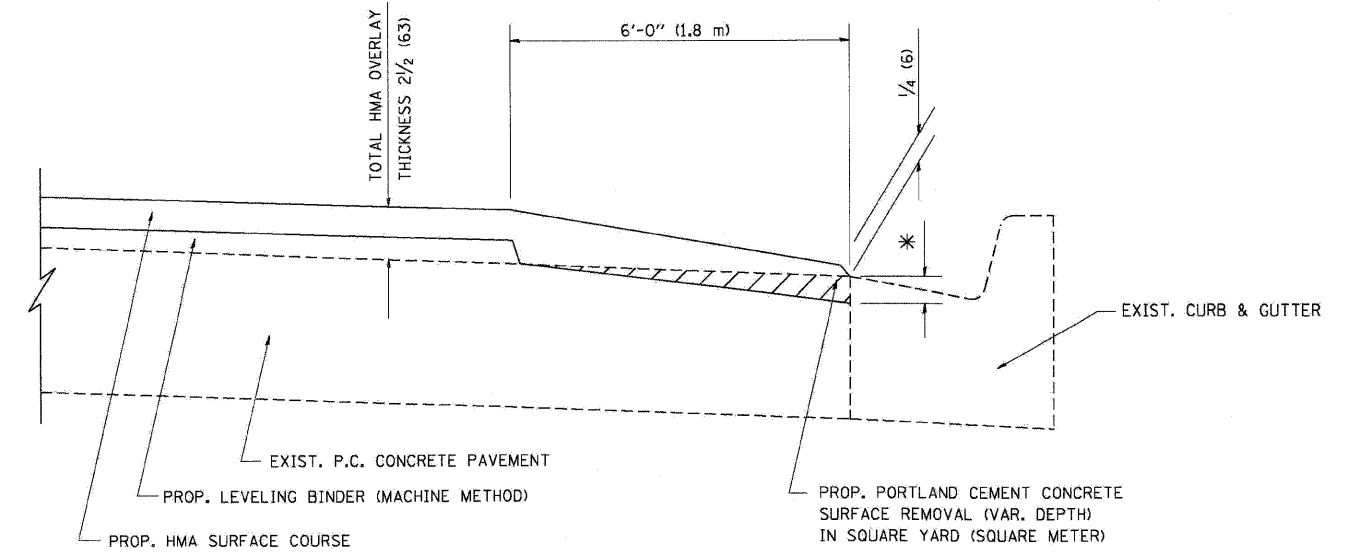

HMA TAPER AT
EDGE OF P.C.C PAVEMENT

HMA SURFACE	THICKNESS	LEVELING BINDER	THICKNESS	* MILLING AT GUTTER FLAG
C OR D	1 1/2 (38)	1	(25)	1/4 (33)
F	1 3/4 (44)	3/4	(19)	1/2 (38)

BD-33

ALL DIMENSIONS ARE IN INCHES (MILLIMETERS) UNLESS OTHERWISE SHOWN.

FILE NAME =	DESIGNED - AJP	REVISED -
...\\corp1n\ABC_C2.D1.BD-33.dgn	DRAWN - TMB	REVISED -
USER NAME = tblank	CHECKED - JMM	REVISED -
PLOT DATE = 11/12/2009	DATE - 10/16/09	REVISED -

benesch

**STATE OF ILLINOIS
DEPARTMENT OF TRANSPORTATION**

HMA TAPER AT EDGE OF PCC PAVEMENT

SCALE: N.T.S. SHEET NO. 4 OF 15 SHEETS STA. TO STA.

F.A.I. RTE.	SECTION	COUNTY	TOTAL SHEETS	SHEET NO.
290	(3031.1, ETC., 3838)RS-5	COOK	298	287
FED. ROAD DIST. NO. ILLINOIS FED. AID PROJECT			CONTRACT NO. 60G52	

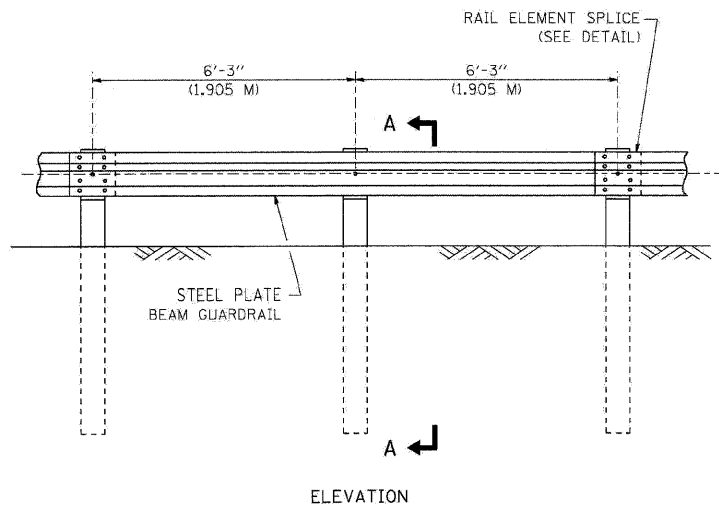

ELEVATION
TYPE A
6'-3" (1.905 M) TYPICAL POST SPACING

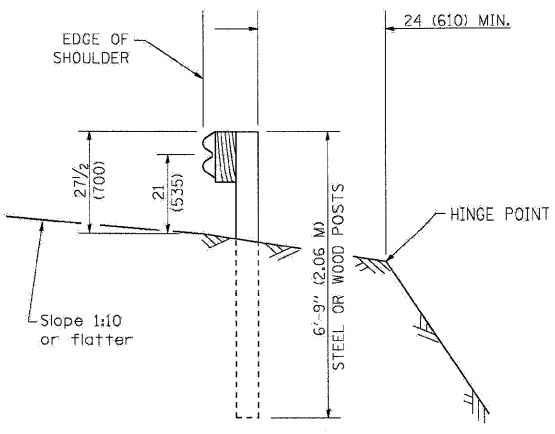

SECTION A-A

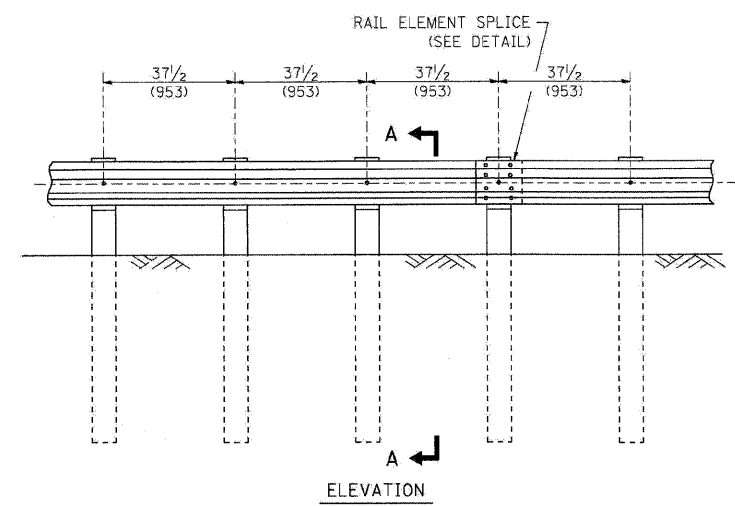

ELEVATION
TYPE A
37 1/2 (953) CLOSED POST SPACING

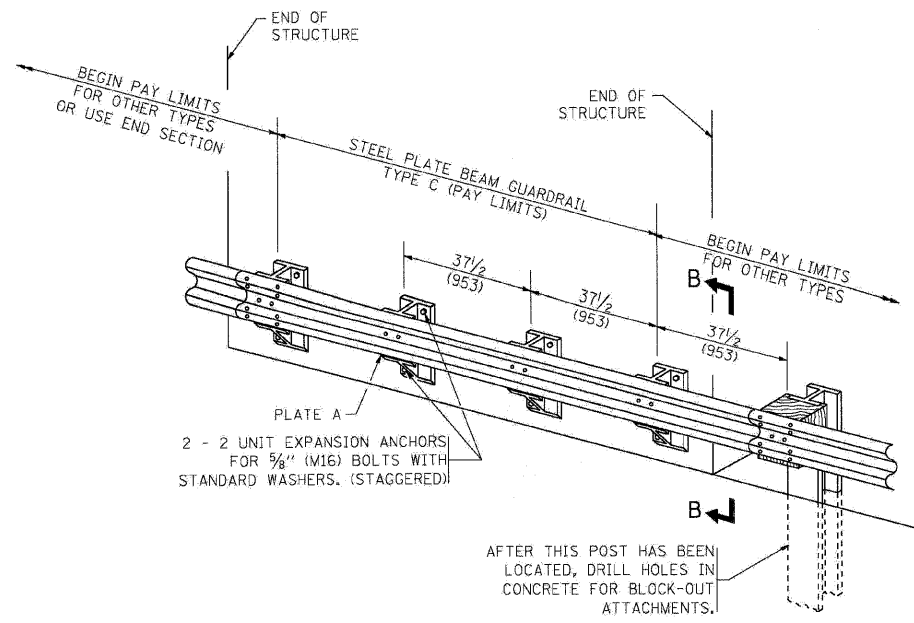

TYPE C
37 1/2 (953) BLOCK-OUT SPACING

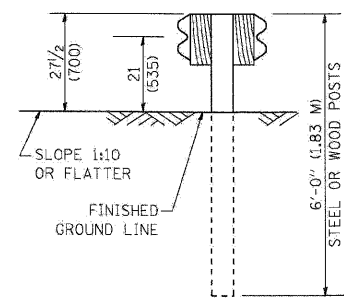

SECTION C-C

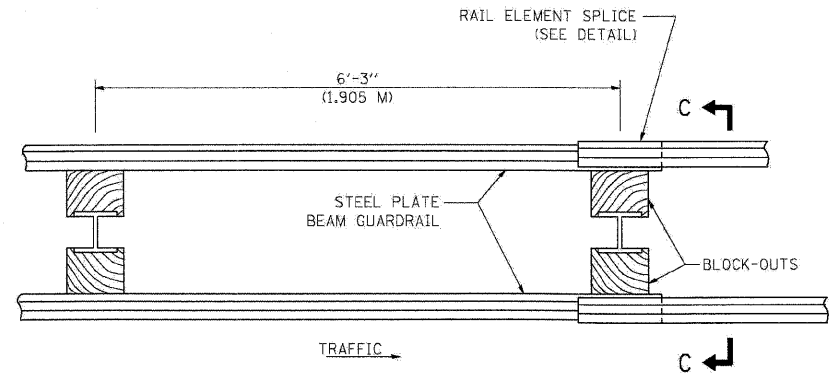

PLAN
TYPE D
DOUBLE STEEL PLATE BEAM GUARDRAIL
6'-3" (1.905 M) TYPICAL POST SPACING

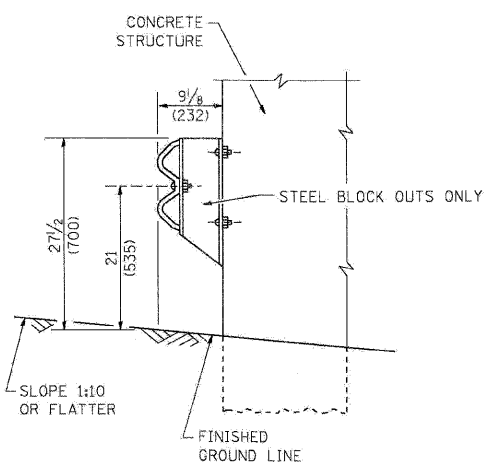

SECTION B-B

GENERAL NOTES

ALL SLOPE RATIOS ARE EXPRESSED AS UNITS OF VERTICAL DISPLACEMENT TO UNITS OF HORIZONTAL DISPLACEMENT (V:H).
ALL DIMENSIONS ARE IN INCHES (MILLIMETERS) UNLESS OTHERWISE SHOWN.
THE EXISTING STEEL POSTS MAY BE DRILLED TO MATCH THE BOLT PATTERN SHOWN HEREIN FOR THE WOOD BLOCK-OUT, OR A NEW STEEL POST SHALL BE PROVIDED.
THIS DETAIL IS APPLICABLE TO THE GUARDRAIL SYSTEM USED PRIOR TO JANUARY 1, 2007. FOR DETAILS ON THE MIDWEST GUARDRAIL SYSTEM, SEE STANDARD 630001.

BM-21

FILE NAME =	DESIGNED - AJP	REVISED -
...:\prip\in_ABC_C22.D1.BM-21A.dgn	DRAWN - TMB	REVISED -
USER NAME = tblank	CHECKED - JMM	REVISED -
PLOT DATE = 11/12/2009	DATE - 10/16/09	REVISED -

benesch

**STATE OF ILLINOIS
DEPARTMENT OF TRANSPORTATION**

REMOVE AND REERECT GUARDRAIL

SCALE: N.T.S. SHEET NO. 5 OF 15 SHEETS STA. TO STA.

F.A.I. RTE.	SECTION	COUNTY	TOTAL SHEETS	SHEET NO.
290	(3031.1, ETC., 3838)RS-S	COOK	298	288
FED. ROAD DIST. NO. ILLINOIS FED. AID PROJECT			CONTRACT NO. 60652	

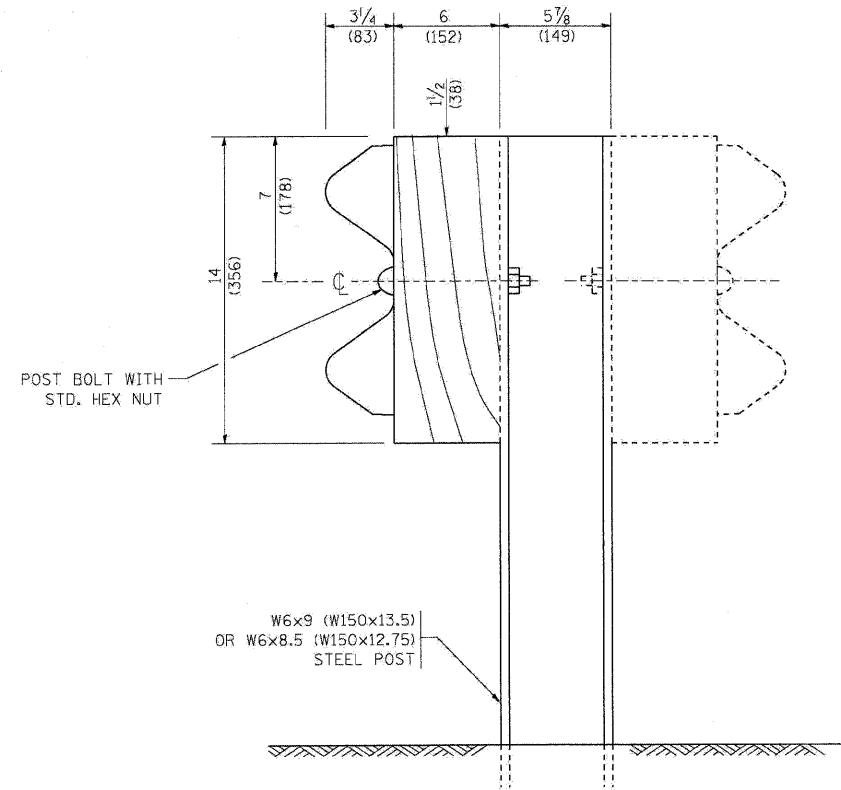

STEEL POST CONSTRUCTION

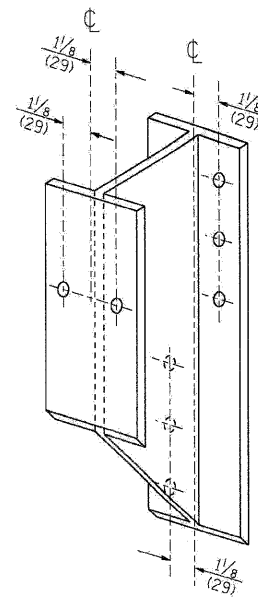

STEEL BLOCK-OUT DETAIL

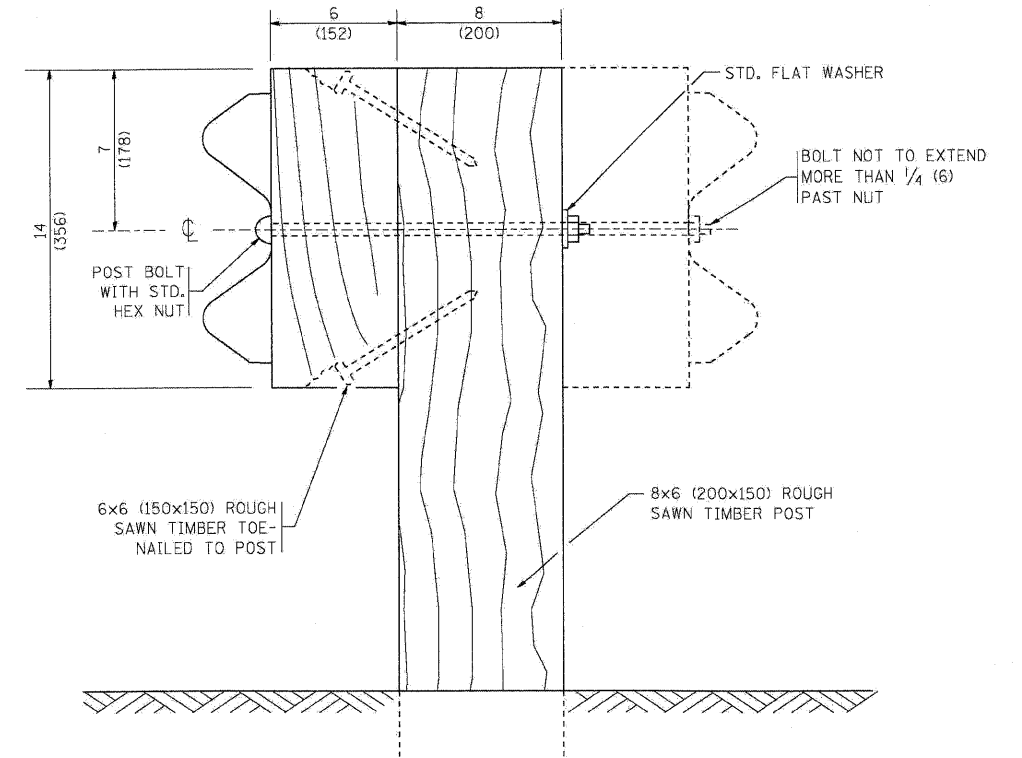

WOOD POST CONSTRUCTION

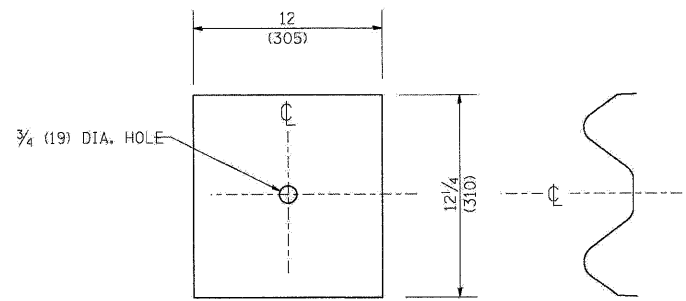

NOTE:

PLATE A SHALL BE PLACED BETWEEN RAIL ELEMENT AND BLOCK-OUT AT NON-SPLICE MOUNTING POINTS ONLY WHEN STEEL BLOCK-OUTS ARE USED.

PLATE A

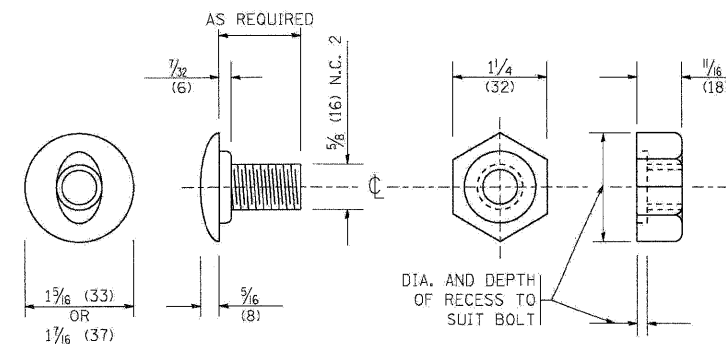

POST OR SPLICE BOLT & NUT

FILE NAME =	DESIGNED - AJP	REVISED -
...prp1n_ABC_C2_01_BM-21B.dgn	DRAWN - TMB	REVISED -
USER NAME = tblank	CHECKED - JMM	REVISED -
PLOT DATE = 11/12/2009	DATE - 10/16/09	REVISED -

benesch

**STATE OF ILLINOIS
DEPARTMENT OF TRANSPORTATION**

REMOVE AND REERECT GUARDRAIL

SCALE: N.T.S. SHEET NO. 6 OF 15 SHEETS STA. TO STA.

F.A.I. RT.C.	SECTION	COUNTY	TOTAL SHEETS	SHEET NO.
290	13031.1, ETC., 38381RS-5	COOK	298	289
FED. ROAD DIST. NO. ILLINOIS FED. AID PROJECT			CONTRACT NO. 60G52	

PLACE STANDARD END SHOE BETWEEN SPLICE PLATE AND RAIL ELEMENT

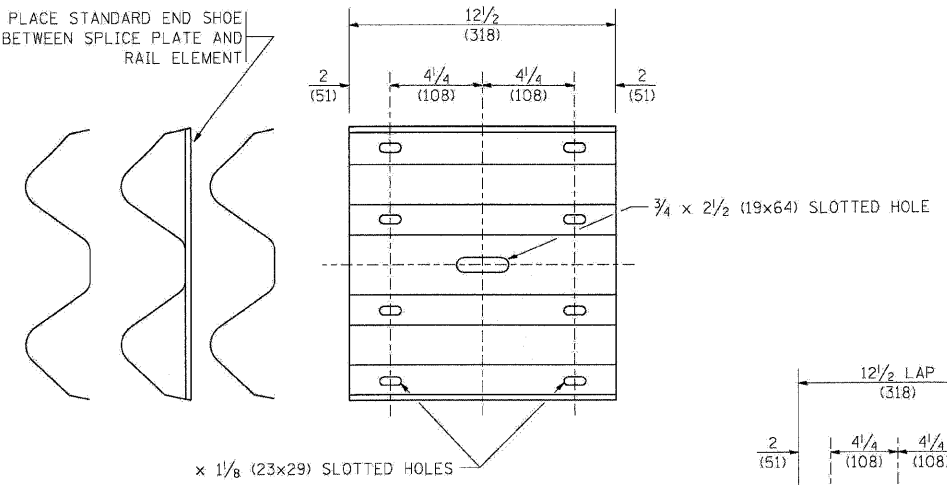

SPLICE PLATE

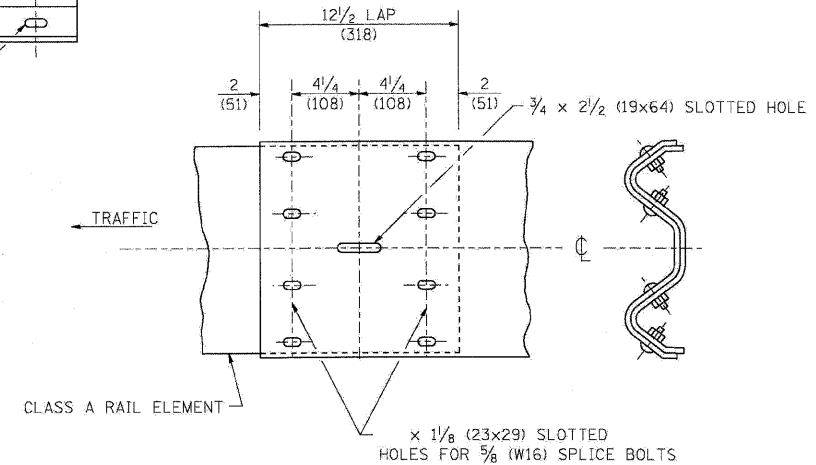

RAIL ELEMENT SPLICE

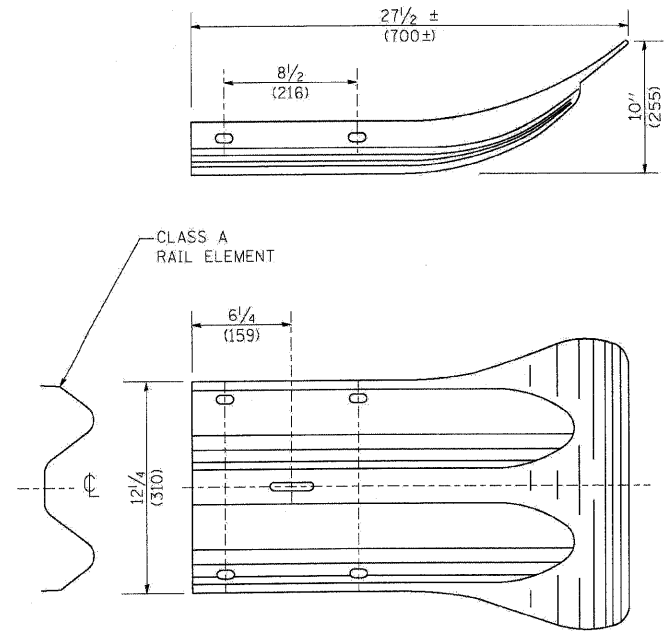

END SECTION

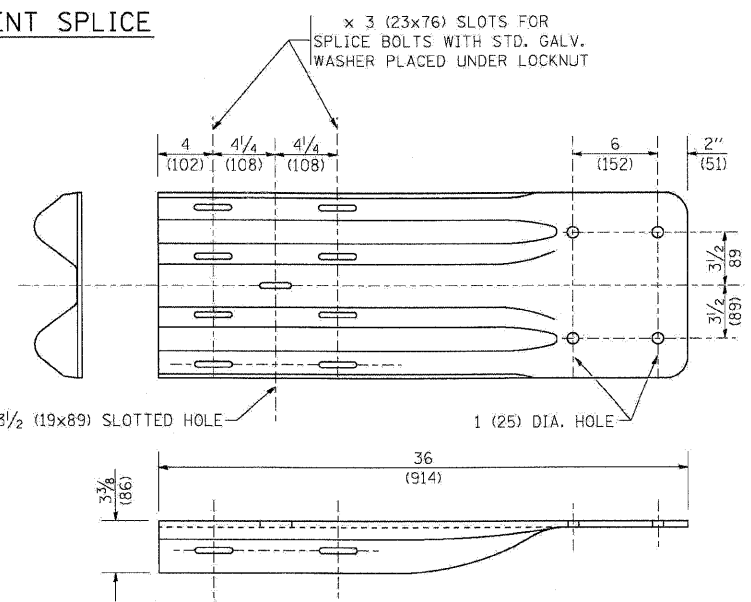

END SHOE

NOTE:
 WHEN END SHOE IS ATTACHED TO A BRIDGE PARAPET WHICH HAS AN EXPANSION JOINT, THE BOLTS SHALL BE PROVIDED WITH A LOCKNUT OR DOUBLE NUT AND SHALL BE TIGHTENED ONLY TO A POINT THAT WILL ALLOW GUARDRAIL MOVEMENT.
 THE STANDARD END SHOE SHALL BE ATTACHED TO THE CONCRETE WITH PRE-DRILLED OR SELF-DRILLING ANCHOR BOLTS. THE ANCHOR CONE SHALL BE SET FLUSH WITH THE SURFACE OF THE CONCRETE.
 EXTERNALLY THREADED STUDS PROTRUDING FROM THE SURFACE OF THE CONCRETE WILL NOT BE PERMITTED.

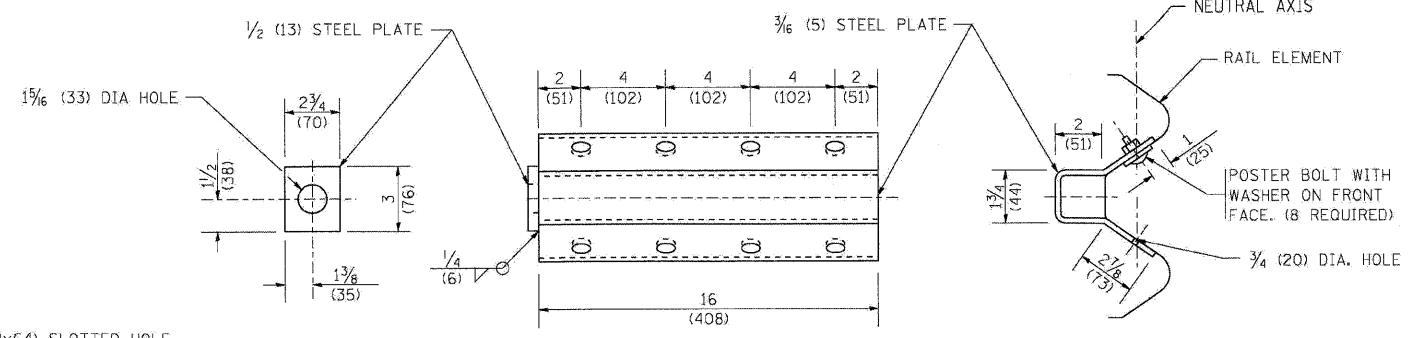

NOTE:
 ANCHOR PLATE T SHALL BE USED TO ATTACH CABLE ASSEMBLY TO GUARDRAIL WHEN REQUIRED ON TRAFFIC BARRIER TERMINALS.

ANCHORE PLATE T DETAILS

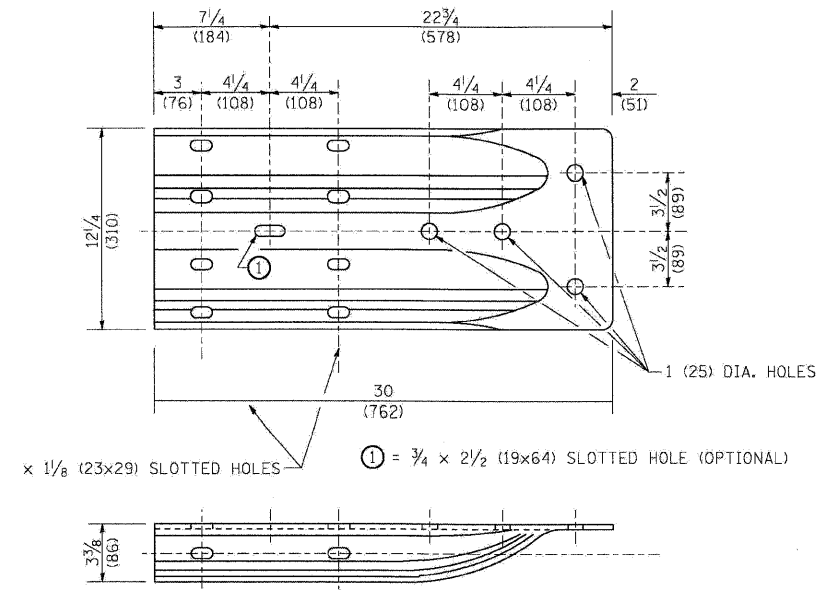

ALTERNATE END SHOE

FILE NAME =	DESIGNED - AJP	REVISED -
...pprpln_ABC.C2.DL.BM-21C.dgn	DRAWN - TMB	REVISED -
USER NAME = tblank	CHECKED - JMM	REVISED -
PLOT DATE = 11/12/2009	DATE - 10/16/09	REVISED -

benesch

**STATE OF ILLINOIS
 DEPARTMENT OF TRANSPORTATION**

REMOVE AND REERECT GUARDRAIL			
SCALE: N.T.S.	SHEET NO. 7 OF 15 SHEETS	STA.	TO STA.

F.A.I. RTE.	SECTION	COUNTY	TOTAL SHEETS	SHEET NO.
290	(3031.1, ETC., 3838)RS-5	COOK	298	290
FED. ROAD DIST. NO.			ILLINOIS FED. AID PROJECT	
			CONTRACT NO. 60G52	

BM-21

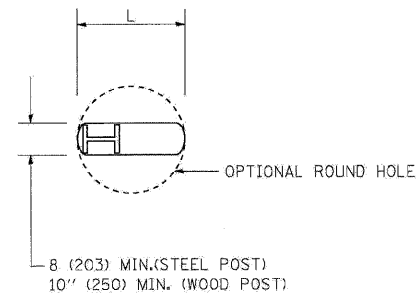

PLAN

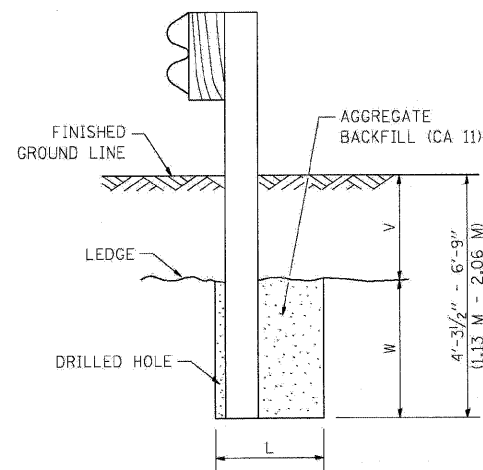

NOTE:
LEDGE LINE IS TOP OF ROCK LEDGE OR HARD SLAG FILL.

ELEVATION

FOOTING FOR POST WHEN IMPERVIOUS MATERIAL IS ENCOUNTERED

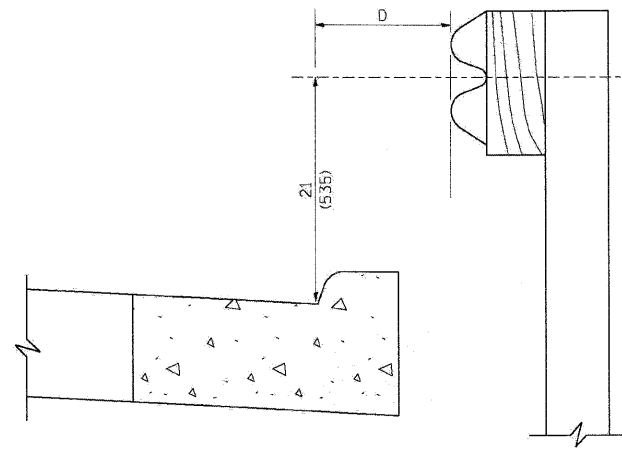

NOTE:

IF IT IS NECESSARY FOR D TO BE MORE THAN 12 (300) AND LESS THAN 10'-0" (3.0 M) TYPE M-2 (M-5) CURB AND CUTTER (STD. 606001) SHALL BE USED IN FRONT OF AND IN ADVANCE OF THE GUARDRAIL.

GUARDRAIL PLACED BEHIND CURB

(D = 0 DESIRABLE TO 12 (300) MAXIMUM)

V	W	L	
		STEEL POST	WOOD POST
0 - 18 (0 - 460)	24 (610)	21 (530)	23 (580)
>18 - 41.5 (> 460 - 825)	12 (305)	8 (203)	10 (250)
>41.5 - 53.5 (> 825 - 1.13 M)	12 - 0 (350 - 0)	8 (203)	10 (250)

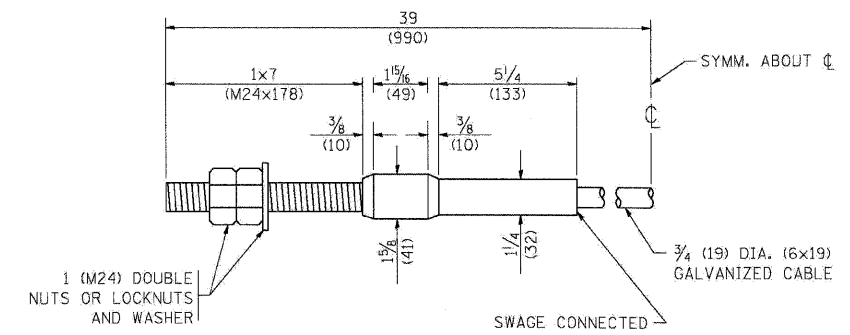
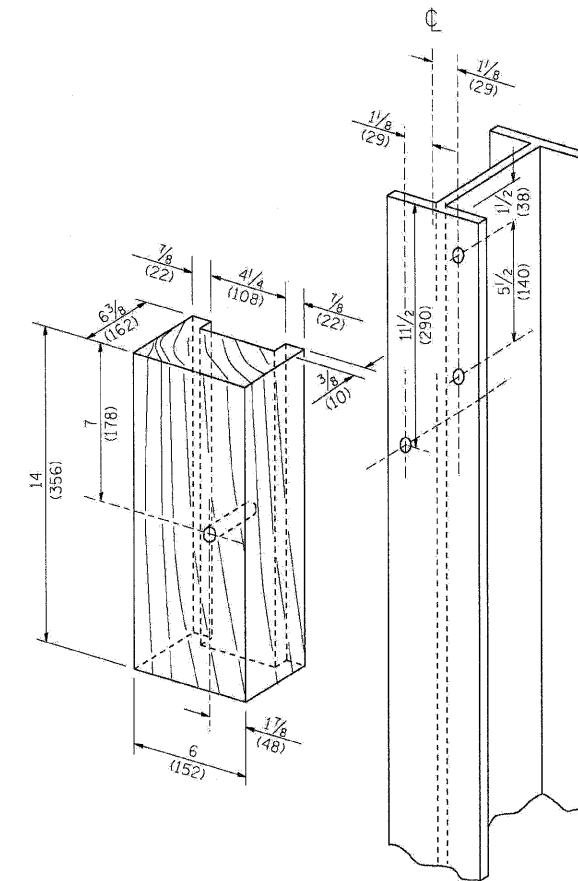

(40,000 LBS (18,100 KG) MIN. BREAKING STRENGTH)
TIGHTEN TO TAUT TENSION

FILE NAME =	DESIGNED - AJP	REVISED -
...prpln_ABC_02_01_BM-210.dgn	DRAWN - TMB	REVISED -
USER NAME = tblank	CHECKED - JMM	REVISED -
PLOT DATE = 11/12/2009	DATE - 10/16/09	REVISED -

benesch

STATE OF ILLINOIS
DEPARTMENT OF TRANSPORTATION

REMOVE AND REERECT GUARDRAIL

SCALE: N.T.S. SHEET NO. 8 OF 15 SHEETS STA. TO STA.

F.A.I. RTE.	SECTION	COUNTY	TOTAL SHEETS	SHEET NO.
290	(3031.J, ETC., 3838)RS-5	COOK	298	291
FED. ROAD DIST. NO.			ILLINOIS FED. AID PROJECT	
			CONTRACT NO. 60C52	

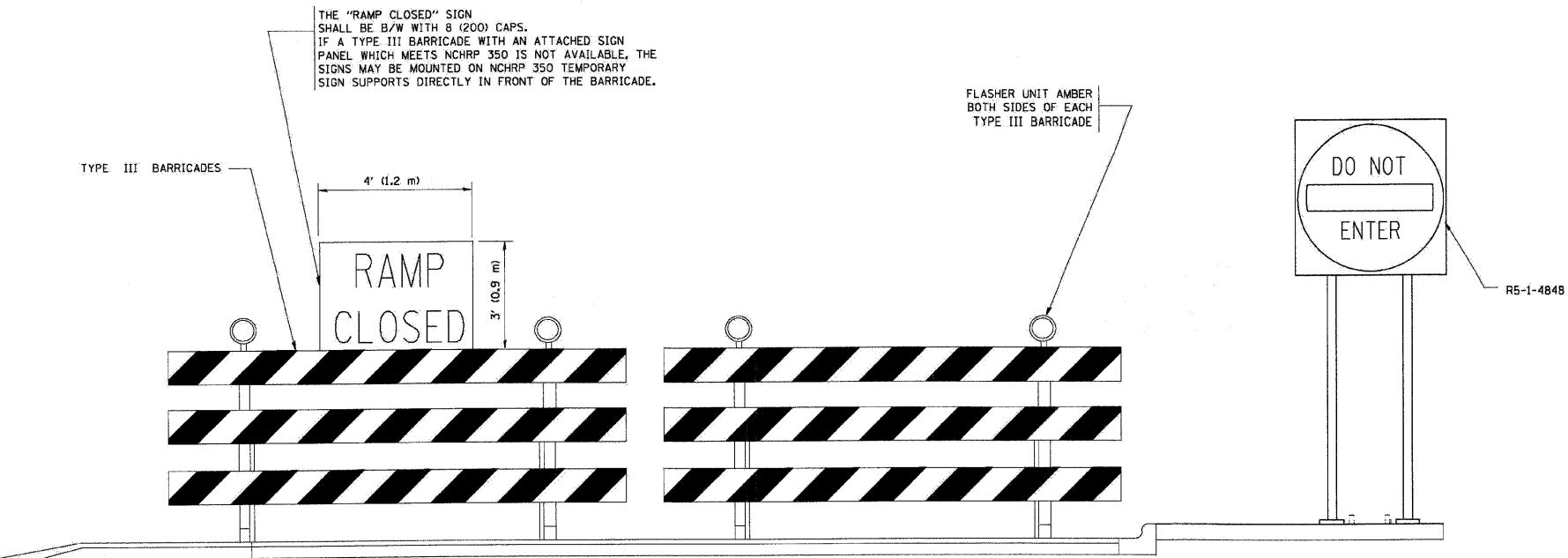
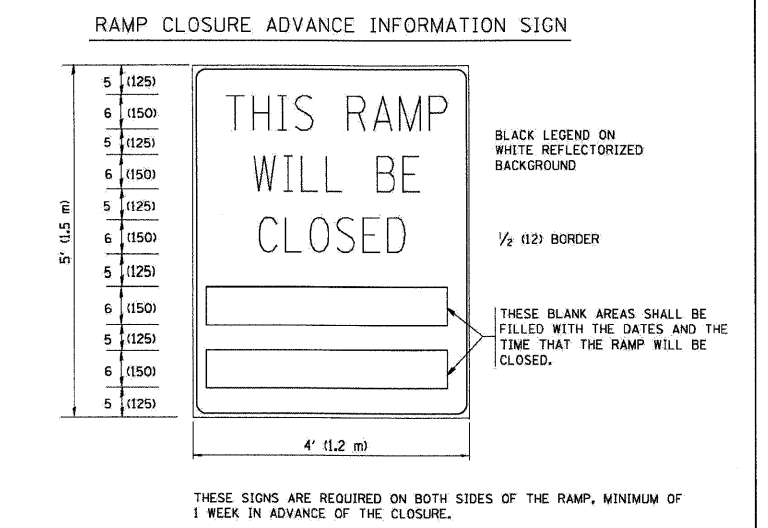
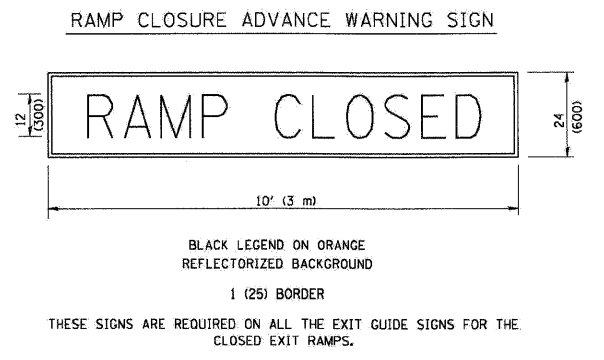
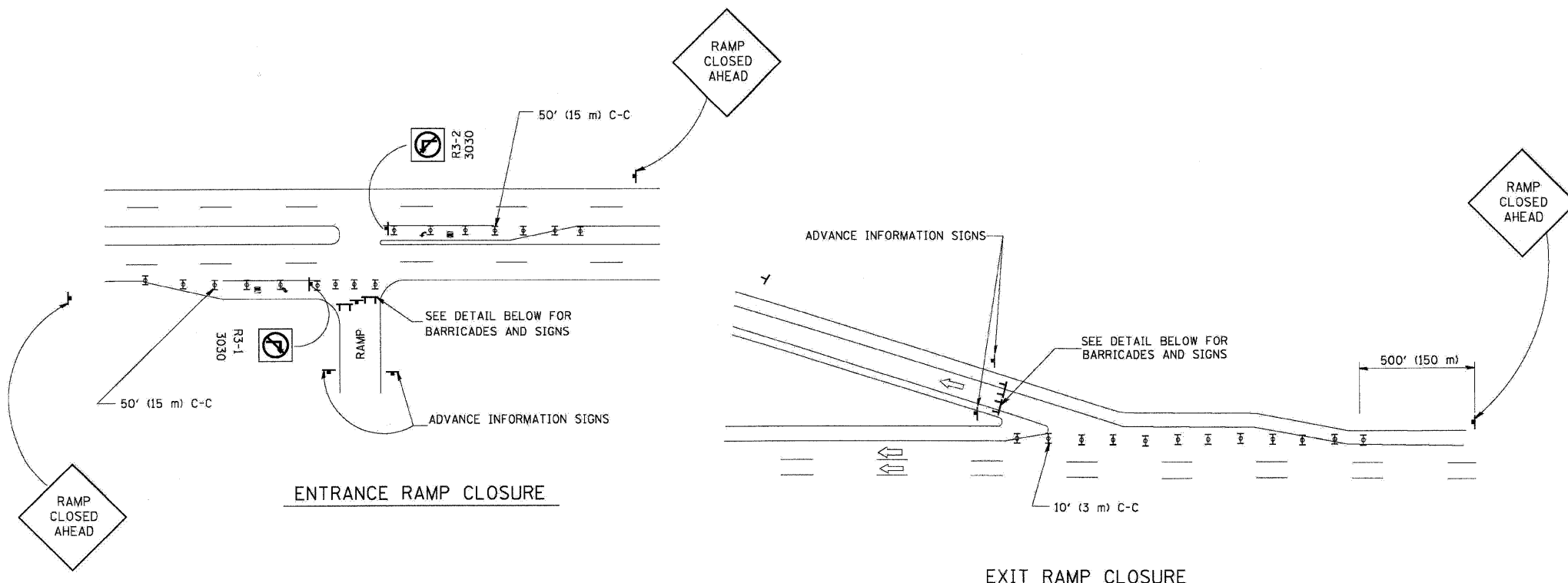

THE "RAMP CLOSED" SIGN SHALL BE B/W WITH 8 (200) CAPS. IF A TYPE III BARRICADE WITH AN ATTACHED SIGN PANEL WHICH MEETS NCHRP 350 IS NOT AVAILABLE, THE SIGNS MAY BE MOUNTED ON NCHRP 350 TEMPORARY SIGN SUPPORTS DIRECTLY IN FRONT OF THE BARRICADE.

- SYMBOLS**
- ▬ TYPE II BARRICADE, DRUM OR VERTICAL BARRICADE WITH STEADY BURN MONO-DIRECTIONAL LIGHT
 - ⌊ TYPE III BARRICADE WITH FLASHING LIGHT

- GENERAL NOTES:**
1. CONES MAY BE SUBSTITUTED FOR DRUMS OR TYPE II BARRICADES DURING DAY OPERATIONS. CONES SHALL BE A MINIMUM OF 28 (700) HIGH.
 2. STEADY BURN LIGHTS WILL NOT BE REQUIRED FOR DAY OPERATIONS.
 3. A FLAGGER SHALL BE POSITIONED AT EACH CLOSED RAMP THAT IS OPEN TO CONSTRUCTION VEHICLES.
 4. ALL ROUTE MARKERS AND TRAILBLAZER ASSEMBLIES WHICH DIRECT MOTORISTS TO A CLOSED ENTRANCE RAMP SHALL BE COVERED.
 5. THE SIGNING AND BARRICADING WHICH IS REQUIRED BY THIS DETAIL SHALL BE INCLUDED IN THE COST OF TRAFFIC CONTROL AND PROTECTION (EXPRESSWAYS).
 6. AUTHORIZATION FROM THE DISTRICT (S BUREAU OF TRAFFIC IS REQUIRED FOR ALL RAMP CLOSURES.
 7. THE RAMP CLOSURE ADVANCE INFORMATION SIGNS SHALL BE ERECTED IF THE CLOSURE TIME EXCEEDS TWENTY-FOUR (24) HOURS. ADDITIONAL ADVANCE WARNING SIGNS ON EXIT GUIDE SIGNING WILL BE REQUIRED FOR EXIT RAMP CLOSURES THAT EXCEED TWENTY FOUR (24) HOURS IN LENGTH.

ALL DIMENSIONS ARE IN INCHES (MILLIMETERS) UNLESS OTHERWISE SHOWN.

FILE NAME =	DESIGNED - AJP	REVISED -
...pprIn_ABC_C2_01_TC-8.sgn	DRAWN - TMB	REVISED -
USER NAME = tblank	CHECKED - JMM	REVISED -
PLOT DATE = 11/12/2009	DATE - 10/16/09	REVISED -

benesch

**STATE OF ILLINOIS
DEPARTMENT OF TRANSPORTATION**

ENTRANCE AND EXIT RAMP CLOSURE DETAILS

SCALE: N.T.S. SHEET NO. 9 OF 15 SHEETS STA. TO STA.

F.A.I. RTE.	SECTION	COUNTY	TOTAL SHEETS	SHEET NO.
290	(3031.I, ETC., 3838)RS-5	COOK	298	292
FED. ROAD DIST. NO. ILLINOIS FED. AID PROJECT			CONTRACT NO. 60652	

TC-08

SINGLE LANE WEAVE

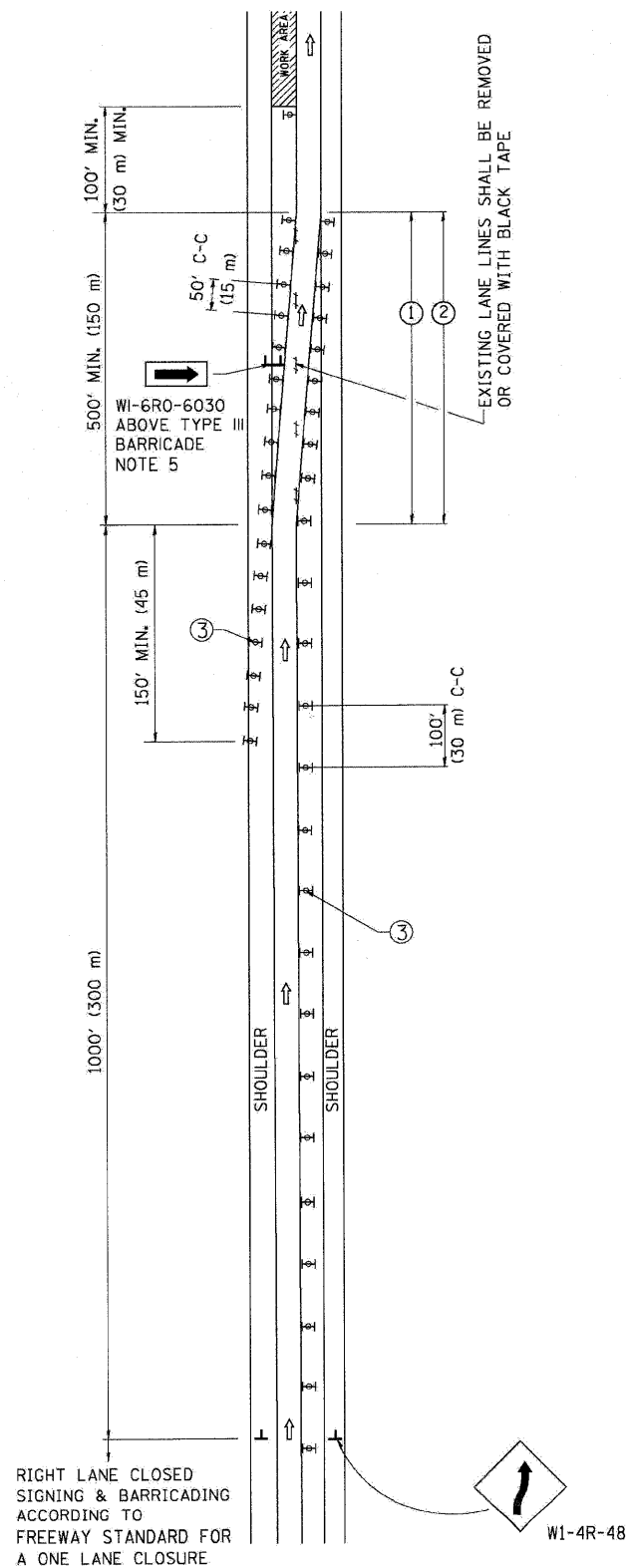

MULTI-LANE WEAVE

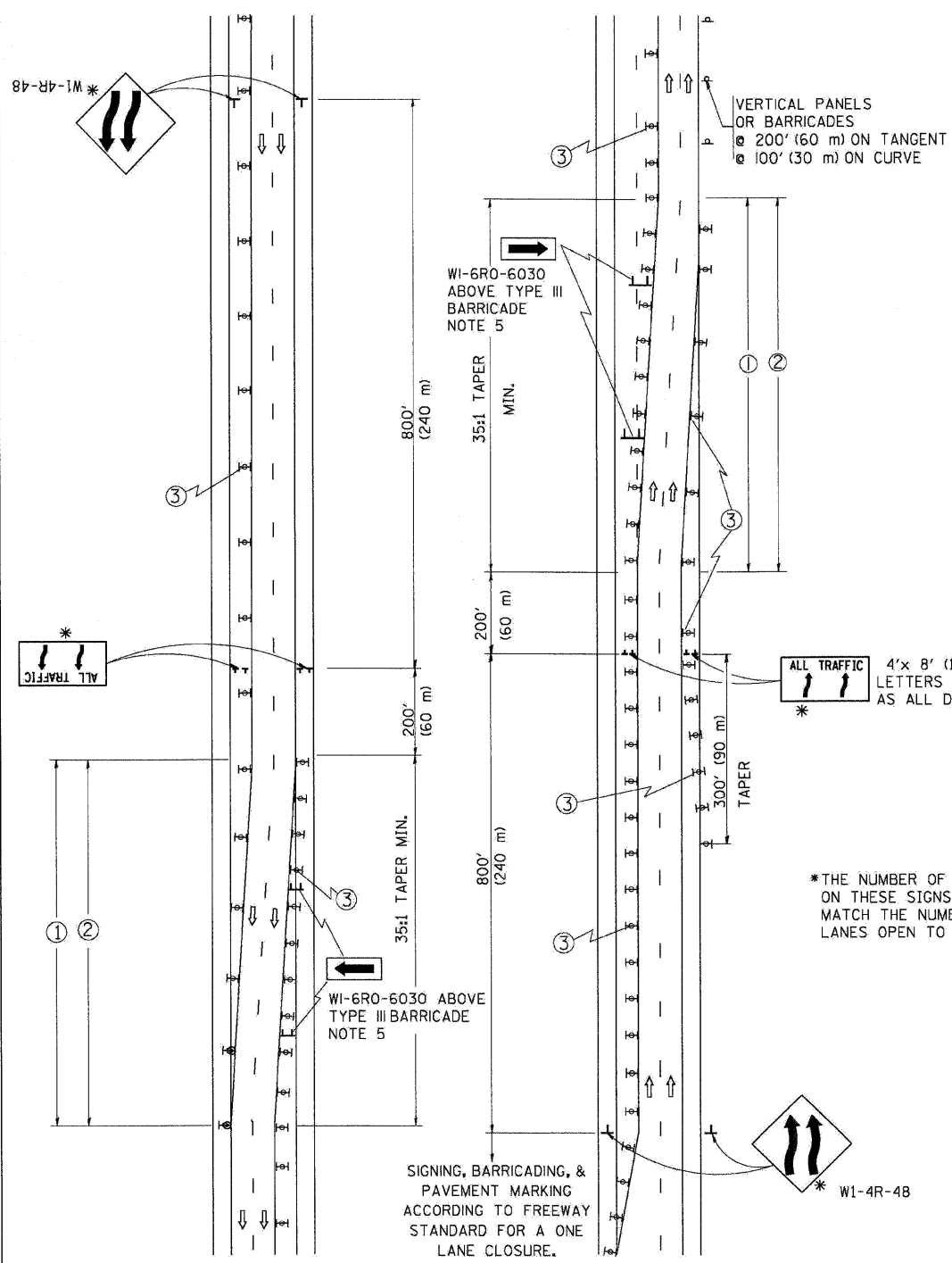

GENERAL NOTES

- ① EXISTING CONFLICTING PAVEMENT MARKING LINES SHALL BE REMOVED OR COVERED WITH BLACK TAPE. PAVEMENT MARKING REMOVAL OR BLACK TAPE SHALL NOT BE REQUIRED FOR LANE CLOSURES UNDER 24 HOURS IN DURATION.
- ② CONTINUOUS REFLECTIVE TEMPORARY PAVEMENT MARKING TAPE SHALL BE PLACED THROUGHOUT THE TAPER AND FOR 300' (90 m) ALONG SIDE THE WORK AREA WHERE THE CLOSURE TIME IS GREATER THAN FOURTEEN DAYS. THE LEFT EDGE LINE SHALL BE YELLOW AND THE RIGHT EDGE LINE SHALL BE WHITE. FOR MULTI-LANE WEAVE LANE LINES SHALL BE 10'-30' (3 m-9 m) SKIP DASH, WHITE.
- ③ PLASTIC DRUMS WITH STEADY BURN LIGHTS AT 50' (15 m) C-C SPACING IN TAPERS AND 100' (30 m) C-C SPACING IN TANGENTS.
- ④ ALL SIGNS SHALL BE POST MOUNTED IF THE CLOSURE TIME EXCEEDS FOUR DAYS.
- ⑤ IF A TYPE III BARRICADE WITH AN ATTACHED SIGN PANEL WHICH MEETS NCHRP 350 IS NOT AVAILABLE, THE SIGNS MAY BE MOUNTED ON NCHRP 350 TEMPORARY SIGN SUPPORTS DIRECTLY IN FRONT OF THE BARRICADE.
- ⑥ IF THE WIDTH OF OFFSET IS LESS THAN 6' THEN THE TYPE III BARRICADE WITH ATTACHED ARROW SIGN PANEL CAN BE ELIMINATED IN THE TAPER AREAS.

SYMBOLS

- ↑ DIRECTION OF TRAFFIC
- ▨ WORK AREA
- ┌ SIGN ON PORTABLE OR PERMANENT SUPPORT
- ⊞ TYPE II BARRICADE, DRUM OR VERTICAL BARRICADE WITH MONO-DIRECTIONAL STEADY BURNING LIGHT

TC-09
ALL DIMENSIONS ARE IN INCHES (MILLIMETERS) UNLESS OTHERWISE SHOWN

FILE NAME =	DESIGNED - AJP	REVISED -
...\\prip1n.abc.c2.31.TC-9.sgn	DRAWN - TMB	REVISED -
USER NAME = tblank	CHECKED - JMM	REVISED -
PLOT DATE = 11/12/2009	DATE - 10/16/09	REVISED -

benesch

**STATE OF ILLINOIS
DEPARTMENT OF TRANSPORTATION**

FREEWAY SINGLE AND MUTI-LANE WEAVE

SCALE: N.T.S. SHEET NO. 10 OF 15 SHEETS STA. TO STA.

F.A.I. RTE.	SECTION	COUNTY	TOTAL SHEETS	SHEET NO.
290	(3031.1, ETC., 3838)RS-5	COOK	298	293
FED. ROAD DIST. NO. ILLINOIS FED. AID PROJECT			CONTRACT NO. 60652	

THE DIAGONAL LINES SHALL BE SPACED AT 40' (12 m) C-C ACROSS ALL STRUCTURES WHICH ARE 500' (150 m) OR LESS IN LENGTH
THE DIAGONAL LINES ARE NOT REQUIRED ON SHOULDERS WHICH ARE 6' (1.8 m) OR LESS IN WIDTH

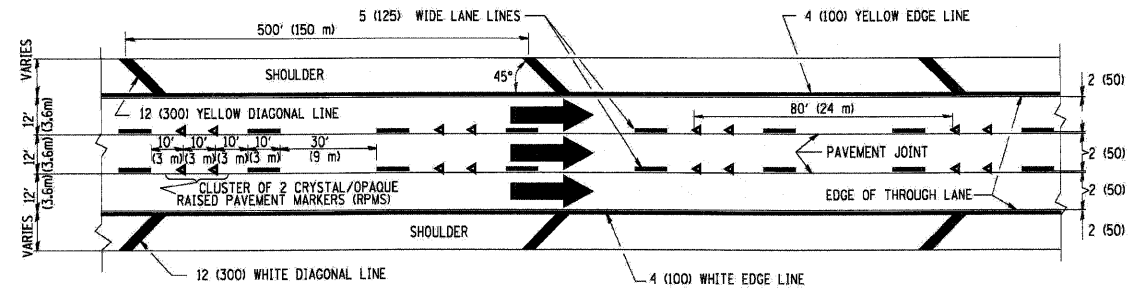

TYPICAL EDGE LINES & LANE LINES

NOTES:

1. THERMO PLASTIC PAVEMENT MARKING LINE SHALL BE USED FOR THE EDGE LINES, GORE LINES, AND DIAGONAL LINES ON BITUMINOUS PAVEMENT ONLY.
2. PREFORMED PLASTIC TYPE B PAVEMENT MARKING LINE SHALL BE USED FOR ALL LANE LINES ON BITUMINOUS PAVEMENT
3. POLYUREA PAVEMENT MARKING SHALL BE USED FOR ALL MARKINGS ON PCC

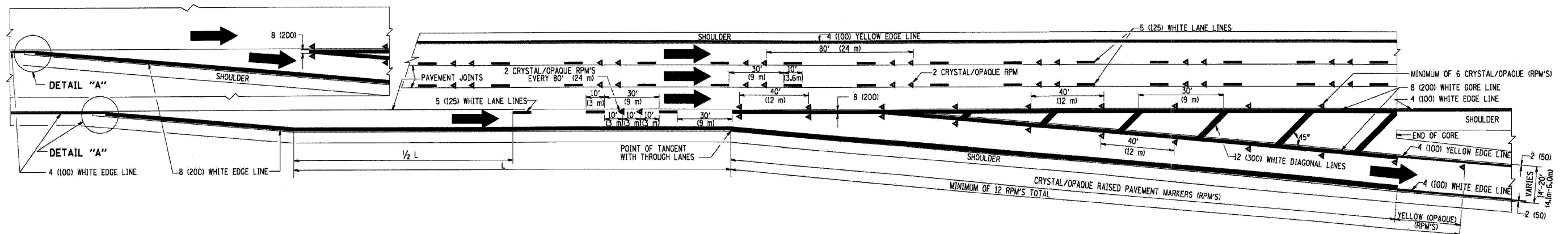
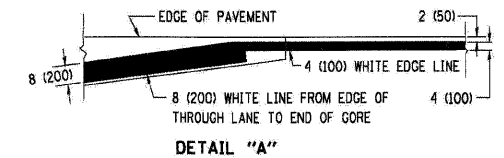

TYPICAL EXIT RAMP PAVEMENT MARKINGS

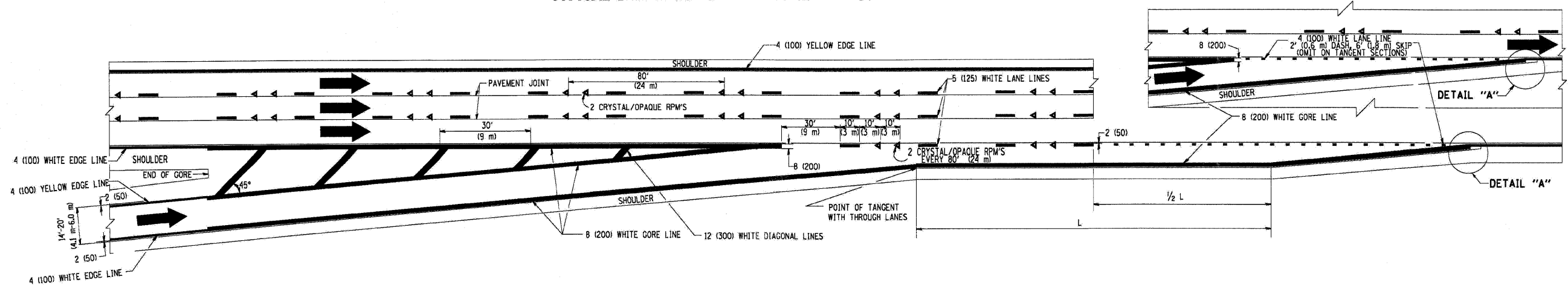

TYPICAL ENTRANCE RAMP PAVEMENT MARKINGS

FILE NAME =	DESIGNED - AJP	REVISED -	benesch	STATE OF ILLINOIS DEPARTMENT OF TRANSPORTATION	MULTI-LANE FREEWAY PAVEMENT MARKING		F.A.I. RTE.:	SECTION	COUNTY	TOTAL SHEETS	SHEET NO.
m:\ppln\ABC.C2.D1.TC-12A.dgn	DRAWN - TMB	REVISED -					290	(3031.I, ETC., 3838)RS-5	COOK	298	294
USER NAME = tblank	CHECKED - JMM	REVISED -					CONTRACT NO. 60G52				
PLOT DATE = 11/12/2009	DATE - 10/16/09	REVISED -					SCALE: N.T.S.	SHEET NO. 11 OF 15 SHEETS	STA. TO STA.	FED. ROAD DIST. NO.	ILLINOIS FED. AID PROJECT

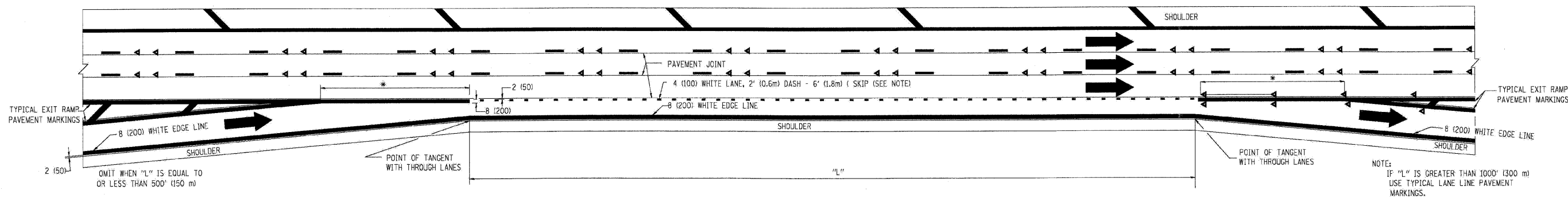

TYPICAL ENTRANCE/EXIT RAMP COMBINATION PAVEMENT MARKINGS

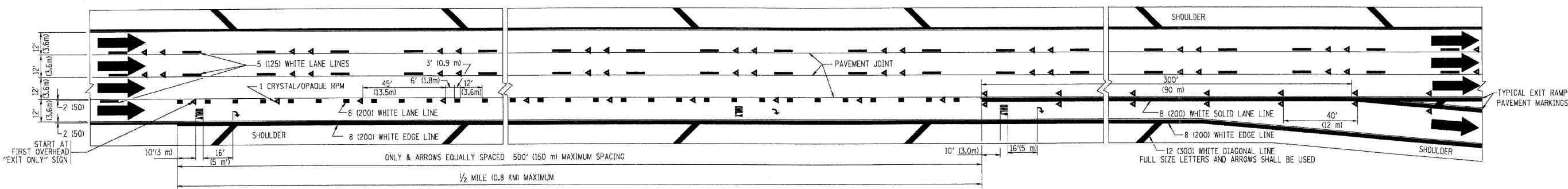

TYPICAL EXIT ONLY LANE PAVEMENT MARKINGS

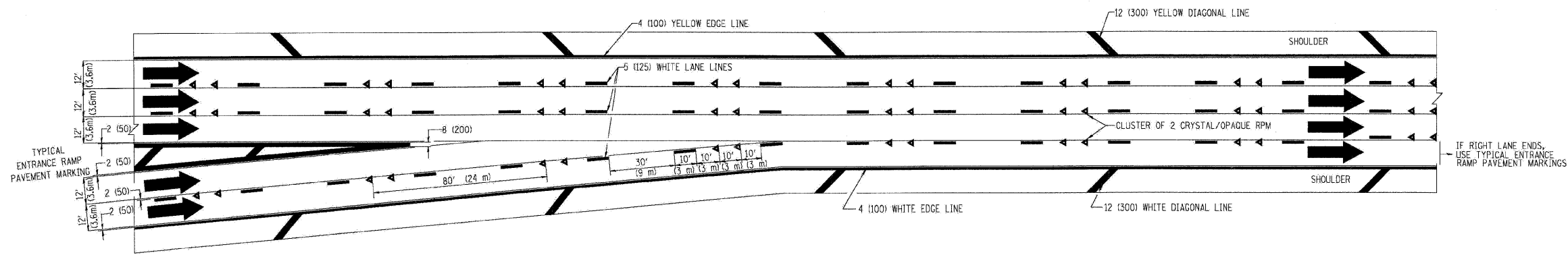

TYPICAL TWO LANE ENTRANCE RAMP PAVEMENT MARKINGS

FILE NAME =	DESIGNED - AJP	REVISED -	benesch	STATE OF ILLINOIS DEPARTMENT OF TRANSPORTATION	MULTI-LANE FREEWAY PAVEMENT MARKING			F.A.I. RTE.	SECTION	COUNTY	TOTAL SHEETS	SHEET NO.
...prpIn_ABC.C2.D1.TC-12B.dgn	DRAWN - TMB	REVISED -						290	(3031), ETC., 3838RS-5	COOK	298	295
USER NAME = tblank	CHECKED - JMM	REVISED -						CONTRACT NO. 60652				
PLOT DATE = 11/12/2009	DATE - 10/16/09	REVISED -						FED. ROAD DIST. NO.	ILLINOIS FED. AID PROJECT			
								SCALE: N.T.S.	SHEET NO. 12 OF 15 SHEETS	STA. TO STA.		

PARTIAL RAMP CLOSURE DETAILS

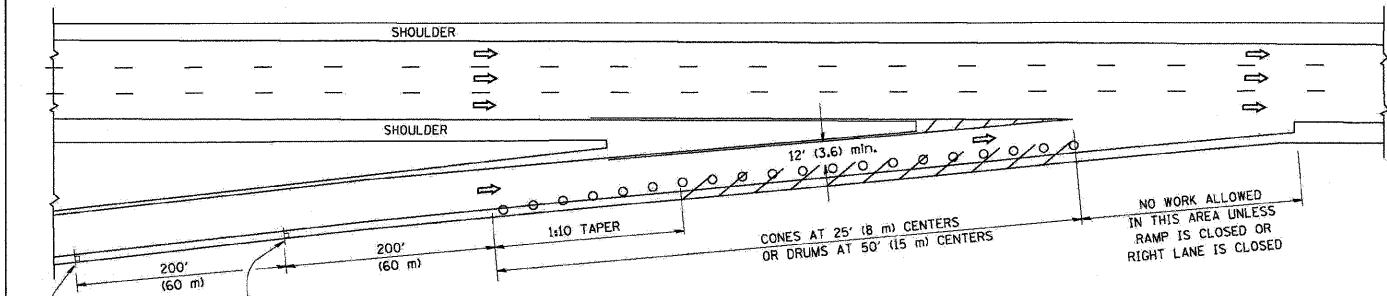

TYPICAL ENTRANCE RAMP

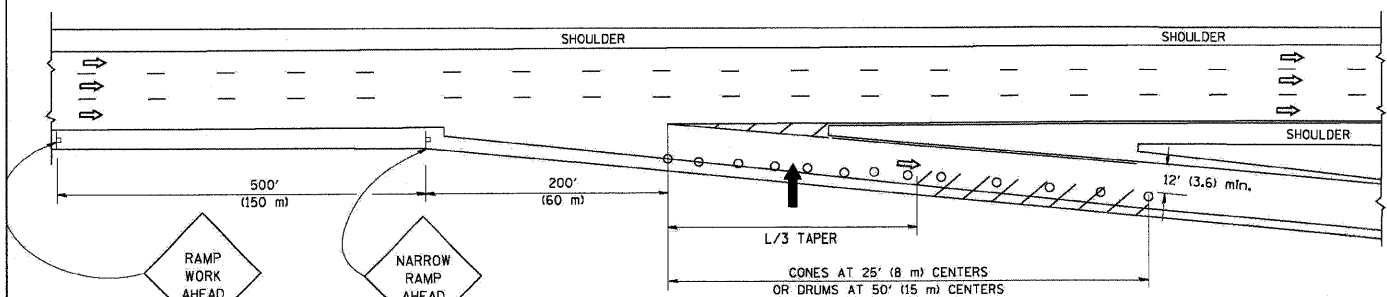

TYPICAL EXIT RAMP

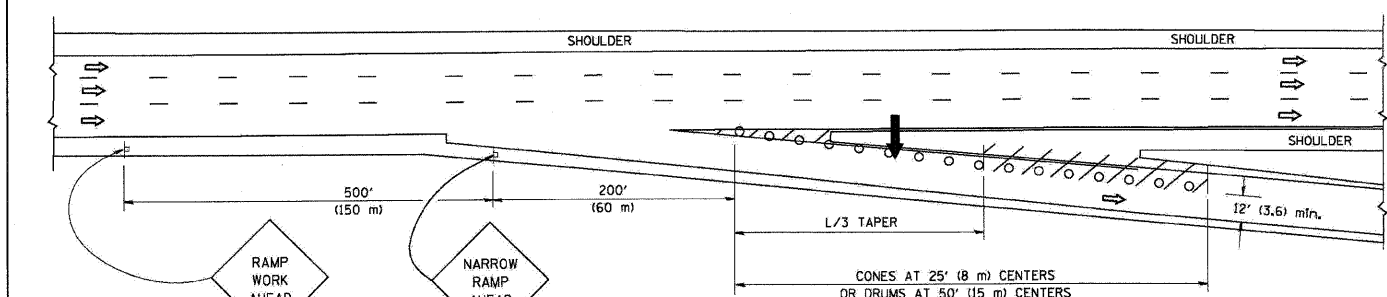

TYPICAL EXIT RAMP

SYMBOLS

- ➔ ARROWBOARD
- ▨ WORK AREA
- ⊥ SIGN ON PORTABLE OR PERMANENT SUPPORT
- FLAGGER WITH CONTROL SIGN
- ⊥ TYPE II BARRICADE, DRUM OR VERTICAL BARRICADE WITH STEADY BURN MONO-DIRECTIONAL LIGHT
- CONE, DRUM OR BARRICADE

GENERAL NOTES

1. THE "L" DISTANCE EQUALS:

SPEED LIMIT	FORMULAS
45 mph (80 km/h) OR GREATER:	METRIC ENGLISH
	$L=0.65(W)(S)$ $L=(W)(S)$

W = WIDTH OF OFFSET IN FEET (METERS)
S = NORMAL POSTED SPEED MPH (KM/H)
2. PLASTIC DRUMS WITH HIGH PERFORMANCE REFLECTIVE SHEETING AND STEADY BURNING LIGHTS ARE REQUIRED FOR ALL NIGHTTIME CLOSURES.
3. ALL SIGNS SHALL BE POST MOUNTED IF THE CLOSURE TIME EXCEEDS FOUR DAYS.
4. FLASHING LIGHTS SHALL BE USED DURING THE HOURS OF DARKNESS AND SHALL BE INSTALLED ABOVE THE FIRST TWO SETS OF SIGNS.

SHOULDER CLOSURE DETAILS

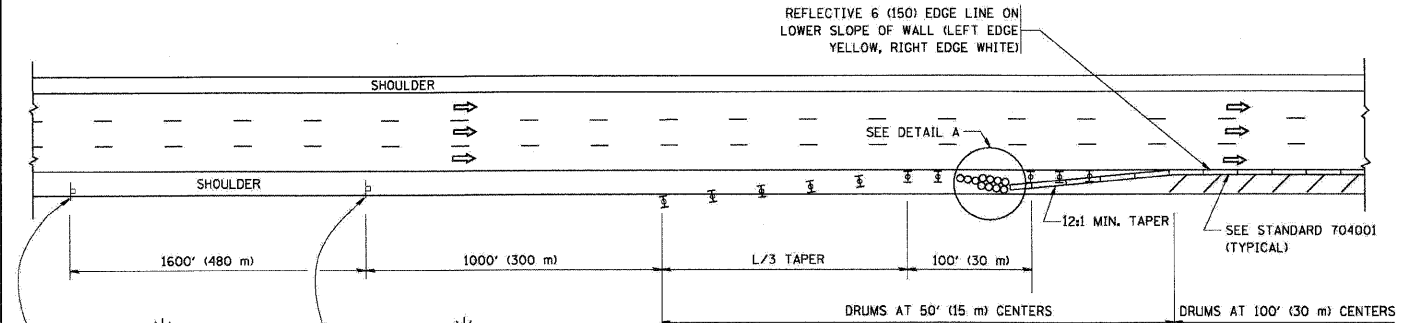

PERMANENT SHOULDER CLOSURE

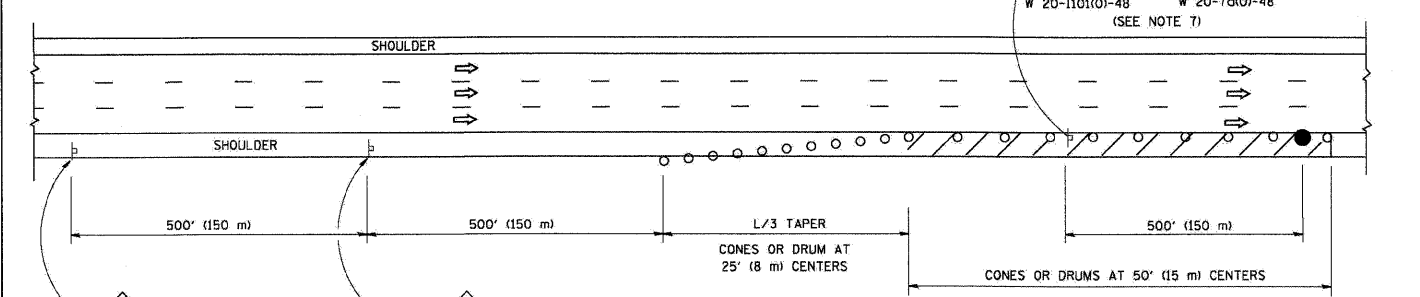

DAYTIME SHOULDER CLOSURE

THIS DETAIL IS USED WHERE:

1. VEHICLES, EQUIPMENT, WORKERS OR THEIR ACTIVITIES ENCR OACH IN AN AREA CLOSER THAN 15' (4.5 m) TO THE EDGE OF PAVEMENT FOR A PERIOD IN EXCESS OF 15 MINUTES.

ARRAY DESIGN PER MANUFACTURER TO BE NCHRP 350 COMPLIANT FOR POSTED SPEED.

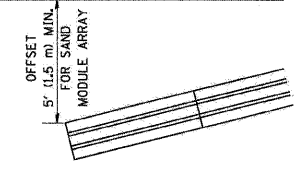

DETAIL "A" IMPACT ATTENUATOR, TEMPORARY (SEE NOTE 5)

ALL DIMENSIONS ARE IN INCHES (MILLIMETERS) UNLESS OTHERWISE SHOWN.

FILE NAME =	DESIGNED - AJP	REVISED -
USER NAME = tblank	DRAWN - TMB	REVISED -
PLOT DATE = 11/12/2009	CHECKED - JMM	REVISED -
	DATE - 10/16/09	REVISED -

benesch

STATE OF ILLINOIS
DEPARTMENT OF TRANSPORTATION

TRAFFIC CLOSURE FOR SHOULDER CLOSURES
AND PARTIAL RAMP CLOSURES

SCALE: N.T.S. SHEET NO. 13 OF 15 SHEETS STA. TO STA.

F.A.T. RTL.	SECTION	COUNTY	TOTAL SHEETS	SHEET NO.
290	(3031.1, ETC., 3838)RS-5	COCK	298	296
CONTRACT NO. 60G52				
FED. ROAD DIST. NO.		ILLINOIS FED. AID PROJECT		

SIGNING FOR FLAGGING OPERATIONS AT WORK ZONE OPENINGS

WORK ZONE EXIT OPENING

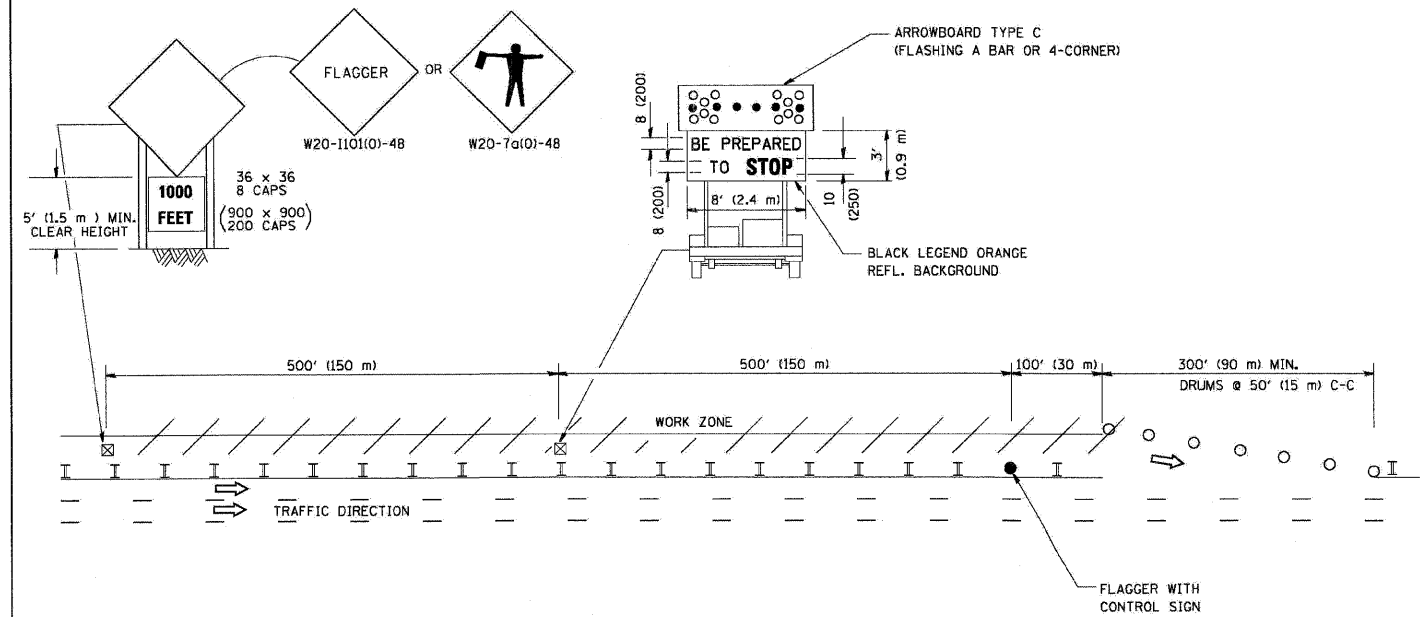

WORK ZONE ENTRY OPENING

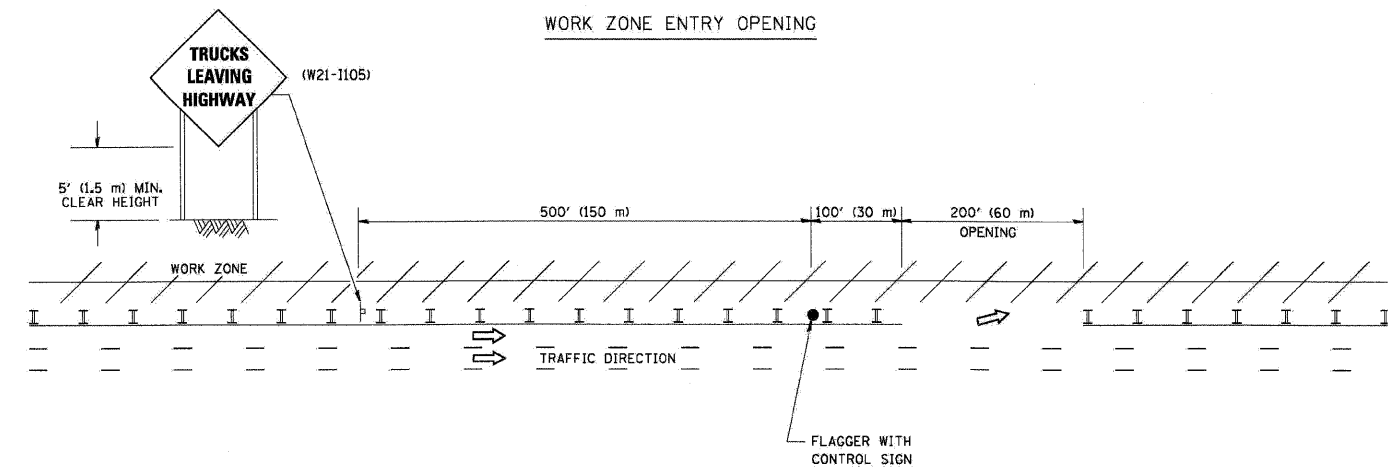

NOTES:

1. The Arrowboard, the Flagger Ahead trailer mounted sign, and the Trucks Leaving Highway sign shall be removed or turned away from traffic and the exit and entry openings shall be closed when the flagging operation ceases.
2. Work Zone Exit Openings should be a minimum of one half mile apart.
3. Exiting the work zone at any place other than at a Work Zone Exit Opening will be prohibited.
4. All vehicles shall enter the work zone at entry openings, using their turn signals to warn motorists.

TC-18

ALL DIMENSIONS ARE IN INCHES (MILLIMETERS) UNLESS OTHERWISE SHOWN

FILE NAME =	DESIGNED - AJP	REVISED -
...NppIn_ABC.C2.D1.TC-18.dgn	DRAWN - TMB	REVISED -
USER NAME = tblank	CHECKED - JMM	REVISED -
PLOT DATE = 11/12/2009	DATE - 10/16/09	REVISED -

benesch

**STATE OF ILLINOIS
DEPARTMENT OF TRANSPORTATION**

**SIGNING FOR FLAGGING OPERATIONS AT
WORK ZONE OPENINGS**

SCALE: N.T.S. SHEET NO. 14 OF 15 SHEETS STA. TO STA.

F.A.I. RTE.	SECTION	COUNTY	TOTAL SHEETS	SHEET NO.
290	(3031.1, ETC., 3838)RS-5	COOK	298	297
FED. ROAD DIST. NO.			ILLINOIS FED. AID PROJECT	
			CONTRACT NO. 60G52	

CENTER LANE CLOSURE

TYPE I CHECK BARRICADES AT 100' (30 m) CENTERS

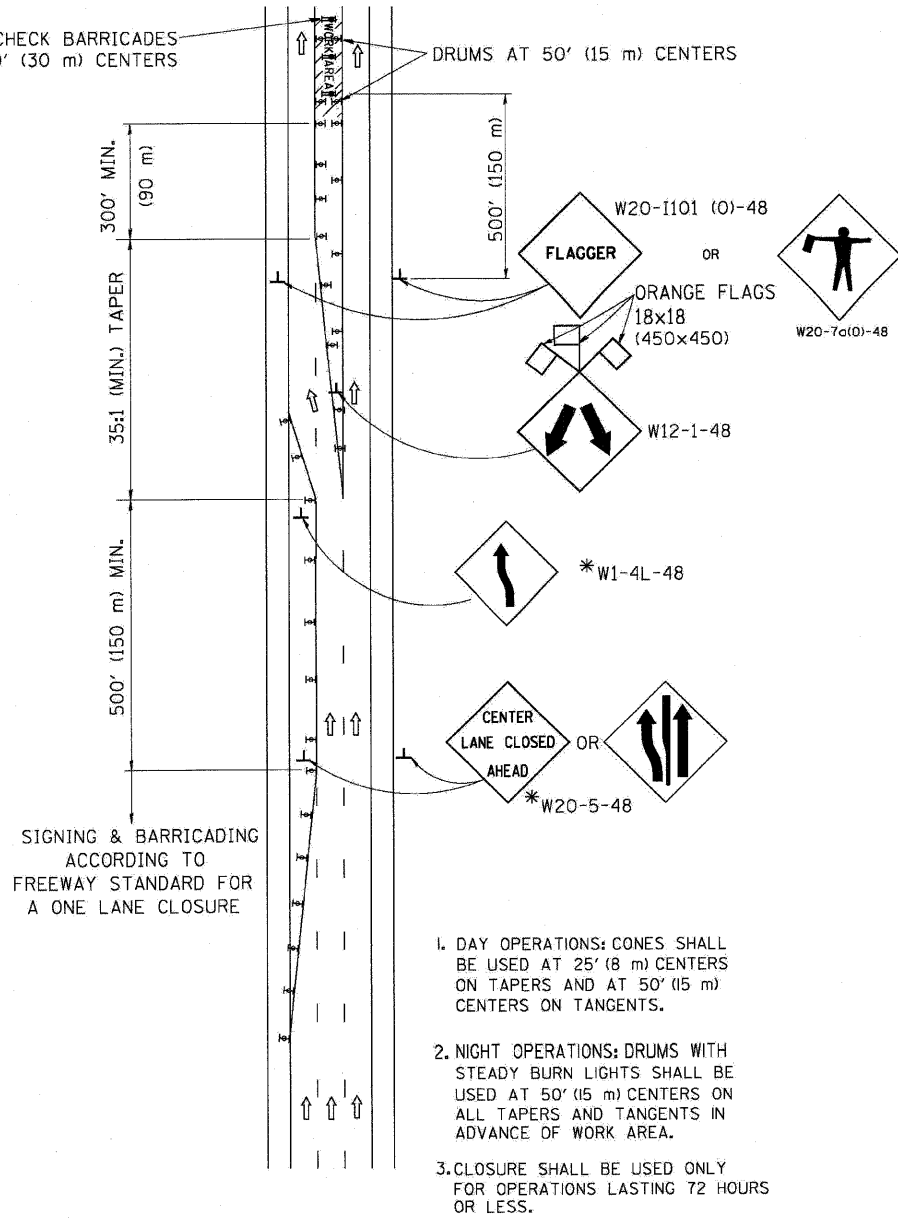

SIGNING & BARRICADING ACCORDING TO FREEWAY STANDARD FOR A ONE LANE CLOSURE

1. DAY OPERATIONS: CONES SHALL BE USED AT 25' (8 m) CENTERS ON TAPERS AND AT 50' (15 m) CENTERS ON TANGENTS.
2. NIGHT OPERATIONS: DRUMS WITH STEADY BURN LIGHTS SHALL BE USED AT 50' (15 m) CENTERS ON ALL TAPERS AND TANGENTS IN ADVANCE OF WORK AREA.
3. CLOSURE SHALL BE USED ONLY FOR OPERATIONS LASTING 72 HOURS OR LESS.

INSTALLATION SEQUENCE

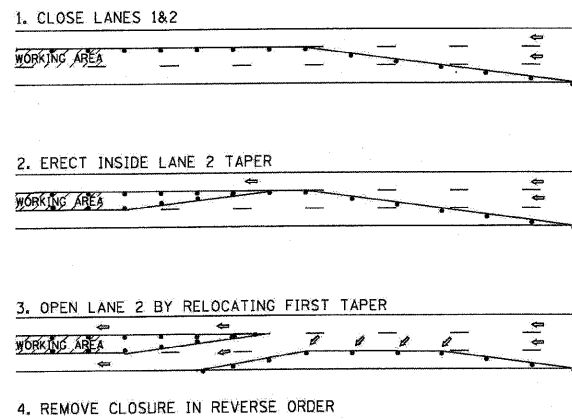

SHOULDER LANE

NOTE: CLOSURE SHALL BE USED ONLY FOR OPERATIONS LASTING 72 HOURS OR LESS.

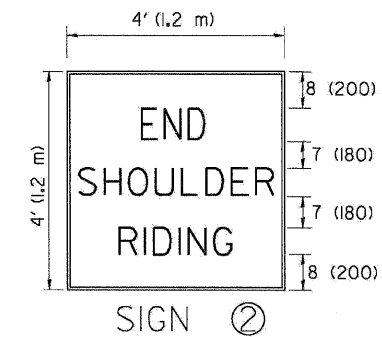
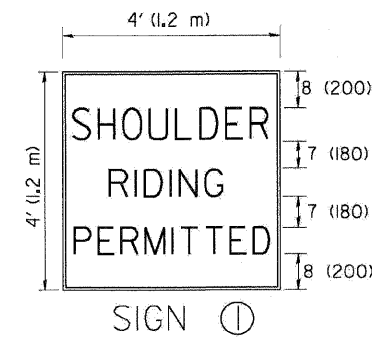
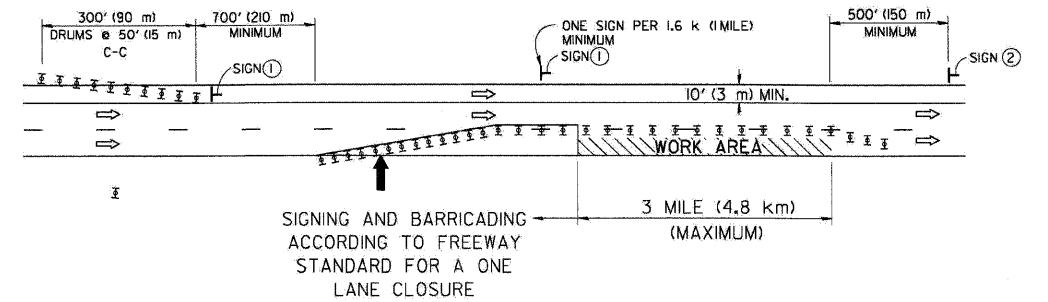
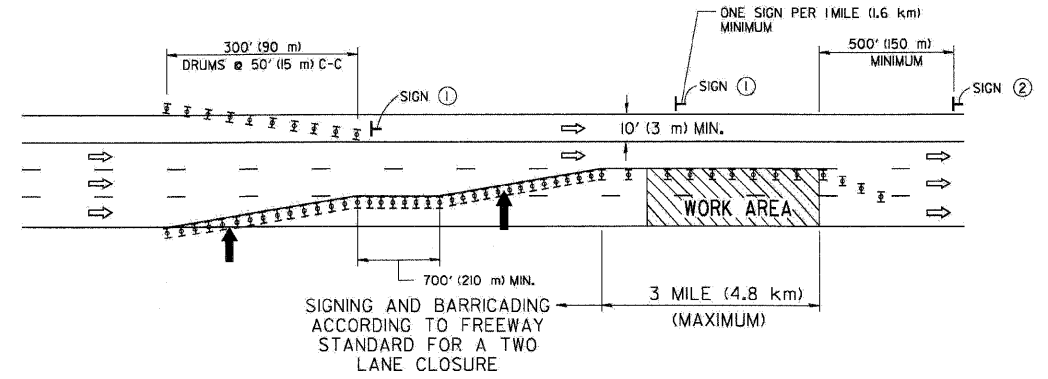

6 (150) SERIES "C" LEGEND
BLACK LEGEND
WHITE REFLECT, BACKGROUND
(25) BORDER

SYMBOLS

- ↑ DIRECTION OF TRAFFIC
- ➔ ARROWBOARD
- ▨ WORK AREA
- ◇ SIGN WITH 18x18 (450x450) ORANGE FLAGS ATTACHED *
- ┌ SIGN ON PORTABLE OR PERMANENT SUPPORT *
- ⊥ TYPE II BARRICADE, DRUM OR VERTICAL BARRICADE WITH MONO-DIRECTIONAL STEADY BURN LIGHT

TC-25

ALL DIMENSIONS ARE IN INCHES (MILLIMETERS) UNLESS OTHERWISE SHOWN

* ALL SIGNS SHALL BE MOUNTED AT A MINIMUM HEIGHT OF 5' (1.5 m).

FILE NAME =	DESIGNED - AJP	REVISED -
USER NAME = tblank	DRAWN - TMB	REVISED -
PLOT DATE = 11/12/2009	CHECKED - JMM	REVISED -
	DATE - 10/16/09	REVISED -

benesch

**STATE OF ILLINOIS
DEPARTMENT OF TRANSPORTATION**

**TRAFFIC CONTROL DETAILS FOR FREEWAY
CENTER LANE CLOSURE SHOULDER LANE**

SCALE: N.T.S. SHEET NO. 15 OF 15 SHEETS STA. TO STA.

F.A.I. RTE.	SECTION	COUNTY	TOTAL SHEETS	SHEET NO.
290	(3031.1, ETC., 3838)RS-5	COOK	298	298
FED. ROAD DIST. NO. [ILLINOIS] FED. AID PROJECT			CONTRACT NO. 60G52	

EASTBOUND SIGN SCHEDULE

SIGN NO.	STATION	LEGEND/DESCRIPTION	EXISTING PANEL DIMENSIONS		PROPOSED PANEL DIMENSIONS		REMOVE SIGN PANEL-TYPE 1 (SQ FT)	REMOVE SIGN PANEL-TYPE 2 (SQ FT)	REMOVE SIGN PANEL-TYPE 3 (SQ FT)	REMOVE SIGN PANEL ASSEMBLY - TYPE A EACH	REMOVE SIGN PANEL ASSEMBLY - TYPE B EACH	SIGN PANEL TYPE 1 (SQ FT)	SIGN PANEL TYPE 2 (SQ FT)	SIGN PANEL TYPE 3 (SQ FT)	WOOD SIGN SUPPORT (FOOT)	TELESCOPING STEEL SIGN SUPPORT (FOOT)	REMOVAL OF SIGN LIGHTING, NO SALVAGE (EACH)
			WIDTH (FT)	HEIGHT (FT)	WIDTH (FT)	HEIGHT (FT)											
EB-TR-48	496+20	290 EAST - CHICAGO	17.0	10.0	17.0	10.0											1.0
EB-TR-49	496+20	EXIT 17 - 12 20 45 - MANNHEIM RD - EXIT ONLY	20.5	12.0	20.5	12.0			170.0					170.0			1.0
EB-WP-49A	501+36	W4-3R	4.0	4.0	4.0	4.0			246.0					246.0			1.0
EB-WP-50	502+00	EXIT 17	6.0	5.0	6.0	5.0				1.0			16.0				18.0
EB-WP-50A	502+82	W4-3R	4.0	4.0	4.0	4.0				1.0				30.0			36.0
EB-TS-50B*	507+66	WOLF RD	5.8	1.5	5.8	1.5											18.0
EB-TS-50C1	522+82	M3-2	2.5	1.3	2.5	1.3				1.0		8.8					18.0
EB-TS-50C2	522+82	M1-1-3 (I 290)	PER MUTCD STD (9FT ²)		PER MUTCD STD (9FT ²)					1.0		3.1					18.0
EB-TS-50E	526+26	R2-1 (55 MPH)	4.0	5.0	4.0	5.0											
EB-WP-50D	533+75	W4-3R	4.0	4.0	4.0	4.0							20.0				18.0
EB-CL-51	538+00	EXIT 17A - 12 20 45 SOUTH - MANNHEIM RD - 1/4 MILE	19.0	12.0	19.0	12.0											
EB-PM-51A	541+20	TRUCKS - USE - 2 - RIGHT - LANES	4.0	5.0	4.0	5.0		20.0	228.0					228.0			1.0
EB-TR-52	550+10	EXIT 17A - 12 20 45 SOUTH - MANNHEIM RD - EXIT ONLY	27.0	8.5	20.5	12.5							20.0				
EB-WP-52A	554+46	W13-3 (30 MPH)	3.0	4.0	4.0	5.0			229.5					256.3			1.0
EB-TR-53	550+10	EXIT 17B - 12 20 45 NORTH - MANNHEIM RD - 1/4 MILE	27.0	8.0	19.5	12.0			216.0					234.0			1.0
EB-WP-54	555+50	EXIT 17A	7.5	5.0	7.0	5.0								35.0			36.0
EB-TS-54A	560+12	W4-1R	4.0	4.0	4.0	4.0				1.0							18.0
EB-WP-54B*	563+30	US RT 12-20-45 - MANNHEIM RD	9.4	2.5	9.4	2.5											36.0
EB-BM-55	563+50	EXIT 17B - 12 20 45 NORTH - MANNHEIM RD	20.5	10.0	20.5	10.0			205.0					205.0			1.0
EB-TS-55A	566+37	W13-3 (20 MPH)	3.0	4.0	4.0	5.0				1.0			20.0				18.0
EB-BM-56	563+50	290 EAST - CHICAGO	12.0	8.0	12.0	8.0			96.0					96.0			1.0
EB-BM-57	563+50	EXITS 18A-B - 25TH AVE - 3/4 MILE	13.5	8.0	13.5	8.0			108.0					108.0			1.0
EB-WP-58	567+60	EXIT 17B	7.5	5.0	7.0	5.0			37.5					35.0			36.0
EB-TS-58A	568+49	W9-1	4.0	4.0	4.0	4.0											18.0
EB-TS-58B	570+37	W4-1R	4.0	4.0	4.0	4.0				1.0			16.0				18.0
EB-PM-58C	575+70	W4-2R	4.0	4.0	4.0	4.0		16.0					16.0				
EB-WP-58D*	577+60	WESTCHESTER BLVD	10.8	1.5	10.8	1.5											36.0
EB-BM-59	577+80	EXIT 18A - SOUTH - 25TH AVE - 1/2 MILE	13.0	10.0	13.0	10.0			130.0					130.0			1.0
EB-WP-59A	582+70	W4-3R	4.0	4.0	4.0	4.0											18.0
EB-TS-59B	590+80	R2-1 (55 MPH)	4.0	5.0	4.0	5.0							20.0				18.0
EB-TS-59C1	593+38	M3-2	2.5	1.3	2.5	1.3				1.0		3.1					18.0
EB-TS-59C2	593+38	M1-1-3 (I 290)	PER MUTCD STD (9FT ²)		PER MUTCD STD (9FT ²)					1.0		9.0					
EB-CL-60	590+80	RIGHT LANE - ENDS - 1000 FEET	14.0	8.0	14.0	8.0											
EB-TR-61	600+00	EXIT 19A - 17TH AVE - 1/2 MILE	13.0	7.5	13.0	7.5			112.0					112.0			1.0
EB-TR-62	600+00	EXIT 18B - NORTH - 25TH AVE - 1/4 MILE	13.5	7.5	13.5	8.5			97.5					97.5			1.0
EB-TR-63	600+00	RIGHT LANE - ENDS - X	14.0	10.0	14.0	10.0			101.3					114.8			1.0
EB-TR-64	600+00	EXIT 18A - SOUTH - 25TH AVE	17.0	7.5	17.0	7.5			140.0					140.0			1.0
EB-PM-64A	600+42	W13-3 (25 MPH)	3.0	4.0	4.0	5.0											1.0
EB-WP-65	602+50	EXIT 18A	7.5	5.0	7.0	5.0		12.0					20.0				
EB-TS-65A	614+37	W4-1R	4.0	4.0	4.0	4.0											36.0
EB-TS-65B	618+44	25TH AVE	6.3	1.5	6.3	1.5							16.0				18.0
EB-BM-66	618+50	EXIT 19A - 17TH AVE - 1/4 MILE	13.0	8.5	13.0	8.5			110.5					110.5			1.0
EB-BM-67	618+50	EXIT 18B - NORTH - 25TH AVE	17.0	8.5	17.0	8.5			144.5					144.5			1.0
EB-BM-67B	618+50	14FT 3IN	5.5	1.5	5.5	1.5											1.0
EB-PM-67A	620+76	W13-3 (25 MPH)	3.0	4.0	4.0	5.0											
EB-WP-68	621+80	EXIT 18B	7.5	5.0	7.0	5.0		12.0					20.0				
EB-TS-68A	624+89	W4-1R	4.0	4.0	4.0	4.0											36.0
EB-CL-69	636+00	EXIT 19A - 17TH AVE	16.0	7.0	16.0	7.0											18.0
EB-PM-69A	638+48	W13-3 (25 MPH)	3.0	4.0	4.0	5.0											1.0
EB-WP-70	639+20	EXIT 19A	7.5	5.0	7.0	5.0											36.0
EB-PM-70A	644+45	TRUCKS - USE - 2 - RIGHT - LANES	4.0	5.0	4.0	5.0		20.0					20.0				
EB-TS-70B*	645+40	17TH AVE	6.1	1.5	6.1	1.5											18.0
EB-BM-71	645+50	EXIT 20 - IL 171 - 1ST AVE - 1 MILE	11.5	8.5	11.5	9.5											
EB-BM-71E	645+50	14FT 3IN	5.5	1.5	5.5	1.5		8.3	97.8					109.3			1.0
EB-TS-71A	651+88	W4-1R	4.0	4.0	4.0	4.0											18.0
EB-TS-71B	662+16	R2-1 (55 MPH)	4.0	5.0	4.0	5.0											18.0
EB-TS-71C1	665+11	M3-2	2.5	1.3	2.5	1.3				1.0		3.1					18.0
EB-TS-71C2	665+11	M1-1-3 (I 290)	PER MUTCD STD (9FT ²)		PER MUTCD STD (9FT ²)					1.0		9.0					
EB-WP-71F	662+00	14FT 3IN	4.0	4.0	4.0	4.0											36.0
EB-BM-72	672+30	LEFT EXIT 21B - IL 43 HARLEM AVE - LEFT 1 3/4 MILES	20.5	9.5	20.5	9.5											
EB-BM-73	672+30	EXIT 21 A - DES PLAINES AVE - 3/4 MILE	21.0	9.5	21.0	9.5			194.8					194.8			1.0
EB-BM-74	672+30	EXIT 20 - IL 171 - 1ST AVE - 1/4 MILE	11.5	9.5	11.5	10.0			199.5					199.5			1.0
EB-BM-74A*	672+30	9TH AVE	5.7	1.5	5.7	1.5			109.3					115.0			1.0
EB-WP-74B	678+20	W4-1R	4.0	4.0	4.0	4.0											18.0
EB-TS-74C	684+75	R2-1 (55 MPH)	4.0	5.0	4.0	5.0											18.0
EB-PM-74D	684+75	R2-1 (55 MPH)	4.0	5.0	4.0	5.0											18.0
EB-BM-75	685+50	EXIT 20 - IL 171 - 1ST AVE	14.5	7.0	14.5	8.0											
EB-BM-75A*	685+50	5TH AVE	5.7	1.5	5.7	1.5											1.0
EB-BM-75B	685+50	14FT 4IN	5.5	1.5	5.5	1.5											1.0
EB-WP-76	690+80	EXIT 20	6.0	5.0	6.0	5.0											1.0
EB-PM-76A	690+82	W13-3 (30 MPH)	3.0	4.0	4.0	5.0											36.0
EB-TS-76B*	698+85	ILL RTE 171 - 1ST AVE	7.2	2.5	7.2	2.5											36.0
EB-WP-76C	704+91	W4-1R	4.0	4.0	4.0	4.0											18.0
EB-PM-76D1	708+94	M3-2	2.5	1.3	2.5	1.3											18.0
EB-PM-76D2	708+94	M1-1-3 (I 290)	PER MUTCD STD (9FT ²)		PER MUTCD STD (9FT ²)												
EB-PM-76E	712+43	R2-1 (55 MPH)	4.0	5.0	4.0	5.0											
EB-PM-76F	715+30	END - TRUCK - LANE - RESTRICTIONS	4.0	5.0	4.0	5.0											
EB-PM-76G	715+30	END - TRUCK - LANE - RESTRICTIONS	4.0	5.0	4.0	5.0											
EB-TR-77	715+30	LEFT EXIT 21B - IL 43 HARLEM AVE - LEFT 1 MILE	17.0	10.5	17.0	10.5			178.5					178.5			1.0

*EXISTING SIGN DIMENSIONS NOT AVAILABLE; PROPOSED SIGN DIMENSIONS USED

FILE NAME =	DESIGNED - SEW	REVISED -	 LIN ENGINEERING, LTD. Consulting Engineers Channah, Illinois Westmont, Illinois			
-------------	----------------	-----------	---	--	--	--

EASTBOUND SIGN SCHEDULE (CONTINUED)

SIGN NO.	STATION	LEGEND/DESCRIPTION	EXISTING PANEL DIMENSIONS		PROPOSED PANEL DIMENSIONS		REMOVE SIGN PANEL-TYPE 1 (SQ FT)	REMOVE SIGN PANEL-TYPE 2 (SQ FT)	REMOVE SIGN PANEL-TYPE 3 (SQ FT)	REMOVE SIGN PANEL ASSEMBLY - TYPE A EACH	REMOVE SIGN PANEL ASSEMBLY - TYPE B EACH	SIGN PANEL TYPE 1 (SQ FT)	SIGN PANEL TYPE 2 (SQ FT)	SIGN PANEL TYPE 3 (SQ FT)	WOOD SIGN SUPPORT (FOOT)	TELESCOPING STEEL SIGN SUPPORT (FOOT)	REMOVAL OF SIGN LIGHTING, NO SALVAGE (EACH)			
			WIDTH (FT)	HEIGHT (FT)	WIDTH (FT)	HEIGHT (FT)														
EB-TR-78	715+30	EXIT 21A - DES PLAINES AVE - 1/2 MILE	18.5	7.5	18.5	7.5			138.8					138.8			1.0			
EB-WP-78A	719+92	DES PLAINES RIVER	4.0	2.0	7.8	2.5				1.0					18.0					
EB-CL-79	734+30	EXIT 21A - DES PLAINES - AVE	18.5	8.5	18.5	8.5			157.3				19.4	157.3			1.0			
EB-PM-79A	738+55	W13-3 (30 MPH)	3.0	4.0	4.0	5.0		12.0					20.0							
EB-WP-80	739+15	EXIT 21A	7.5	5.0	7.0	5.0									36.0					
EB-TR-81	741+70	LEFT EXIT 21B - IL 43 HARLEM AVE - LEFT 1/2 MILE	18.5	10.5	18.5	10.5			194.3					194.3			1.0			
EB-TR-82	741+70	LEFT EXIT 23A - AUSTIN BLVD - LEFT 2 MILES	18.5	7.5	18.5	7.5			138.8					138.8			1.0			
EB-TS-82A*	748+99	DES PLAINES AVE	7.8	2.5	7.8	2.5										18.0				
EB-BM-83	769+75	LEFT EXIT 21B - IL 43 - HARLEM AVE	19.5	9.5	19.5	9.5			185.3				19.4	185.3			1.0			
EB-BM-83A*	769+75	CIRCLE AVE	7.0	1.5	7.0	1.5		10.5					10.5							
EB-PM-83B	771+51	W13-3 (30 MPH)	3.0	4.0	4.0	5.0		12.0					20.0							
EB-WP-84	772+50	EXIT 21B	7.5	5.0	7.0	5.0									36.0					
EB-PM-84A*	779+50	ILL RTE 43 - HARLEM AVE	7.7	2.5	7.7	2.5		19.2					19.2							
EB-TS-84B	789+15	W4-1L	4.0	4.0	4.0	4.0										18.0				
EB-BM-84C*	794+70	HOME AVE	7.0	1.5	7.0	1.5		10.5					16.0							
EB-PM-84D1	801+58	M3-2	2.5	1.3	2.5	1.3	3.1						10.5							
EB-PM-84D2	801+58	M1-1-3 (I 290)	PER MUTCD STD (9FT ²)		PER MUTCD STD (9FT ²)		9.0					3.1	9.0							
EB-PM-84E	805+64	R2-1 (55 MPH)	4.0	5.0	4.0	5.0		20.0					20.0							
EB-BM-85	808+65	LEFT EXIT 23A - AUSTIN BLVD - LEFT 3/4 MILE	15.5	8.5	15.5	8.5			131.8					131.8			1.0			
EB-BM-86	808+65	EXIT 23B - CENTRAL AVE - RIGHT 1 1/4 MILES	17.5	8.5	17.5	8.5			148.8					148.8			1.0			
EB-BM-86A*	808+65	OAK PARK AVE	8.8	1.5	8.8	1.5		13.1					13.1							
EB-PM-86B	812+35	TRUCKS - USE - 2 - RIGHT - LANES	4.0	5.0	4.0	5.0		20.0					20.0							
EB-GM-87	820+80	CHICAGO CITY LIMITS 1 - CHICAGO DOWNTOWN 9	24.5	5.0	25.5	5.5			122.5					140.3						
EB-BM-88	822+10	LEFT EXIT 23A - AUSTIN BLVD - LEFT 1/2 MILE	18.0	8.0	18.0	8.0			144.0					144.0			1.0			
EB-BM-88A*	822+10	EAST AVE	6.0	1.5	6.0	1.5	9.0				9.0									
EB-BM-88B*	835+56	RIDGELAND AVE	9.3	1.5	9.3	1.5		13.9					13.9							
EB-BM-89	849+20	LEFT EXIT 23A - AUSTIN BLVD - 6000 W	20.5	7.5	20.5	7.5			153.8					153.8			1.0			
EB-BM-89A*	849+20	LOMBARD AVE	8.5	1.5	8.5	1.5		12.8					12.8							
EB-PM-89B	851+17	W13-3 (30 MPH)	3.0	4.0	4.0	5.0		12.0					20.0							
EB-WP-90	855+22	EXIT 23A	7.5	5.0	7.0	5.0									36.0					
EB-BM-91	862+60	EXIT 24B - IL 50 CICERO AVE - 1 1/4 MILES	20.0	9.5	20.0	9.5			190.0					190.0			1.0			
EB-BM-92	862+60	EXIT 23B - CENTRAL AVE - RIGHT 1/4 MILE	16.0	9.5	16.0	9.5			152.0					152.0			1.0			
EB-BM-92A*	862+60	AUSTIN BLVD - 6000 W	7.7	2.5	7.7	2.5		19.2					19.2							
EB-WP-92B	871+89	W4-3L	4.0	4.0	4.0	4.0									18.0					
EASTBOUND SUBTOTAL										67	360	5350	9	36	121	891	5760	630	396	34

*EXISTING SIGN DIMENSIONS NOT AVAILABLE; PROPOSED SIGN DIMENSIONS USED

FILE NAME =	DESIGNED - SEW	REVISED -
FILEL	DRAWN - SEW	REVISED -
USER NAME = *USER*	CHECKED - FML	REVISED -
PLOT DATE = *DATE*	DATE - 12/2009	REVISED -



STATE OF ILLINOIS
DEPARTMENT OF TRANSPORTATION

SCHEDULE OF QUANTITIES

SCALE: N.T.S. SHEET NO. 2 OF 4 SHEETS STA. TO STA.

F.A.I. RTE.	SECTION	COUNTY	TOTAL SHEETS	SHEET NO.
290	(3031L, ETC., 3830)RS-5	COOK	413	300
CONTRACT NO. 60G52				
FED. ROAD DIST. NO. ILLINOIS FED. AID PROJECT				