

STAGE III

STAGE III NOTES

- SEQUENCE OF CONSTRUCTION: PAVEMENT PATCHING, HMA SURFACE REMOVAL AND PROPOSED HMA COURSES AS DETAILED IN EACH OPERATION SECTION. WORK CAN OCCUR CONCURRENTLY, BUT SEQUENCE SHALL BE MAINTAINED AND NOT CONFLICT. RAMP WORK WILL BE COMPLETED USING DISTRICT DETAIL TC-8 - FREEWAY AND EXIT RAMP CLOSURE DETAILS.
- LANE AND RAMP CLOSURES ALLOWED AS STIPULATED IN THE SPECIAL PROVISIONS. CONTRACTOR MAY NOT CLOSE ADJACENT EXIT OR ENTRANCE RAMP AT THE SAME TIME.
- SURFACE REMOVAL AND RESURFACING OPERATIONS SHALL NOT BEGIN UNTIL STAGE II IS COMPLETED.
- LANE CLOSURES PER STANDARDS 701400, 701401 AND 701446.
- REDUCE LANE WIDTH USING 35:1 TAPER PER DISTRICT DETAIL TC-9 - TRAFFIC CONTROL DETAILS FOR FREEWAY SINGLE AND MULTI-LANE WEAVE, A W5-1 (48 X 48) ROAD NARROWS SIGN WILL BE ERECTED 500' IN ADVANCE OF THE TAPER.
- THE CONTRACTOR SHALL ERECT ROAD CONSTRUCTION AHEAD SIGNS (W20-I103(0-48)) WITH FLASHING BEACON ON ALL ARTERIAL ROADWAYS APPROACHING INTERCHANGE RAMP.
- GRADE DIFFERENTIAL BETWEEN LANES SHALL NOT EXCEED 2".
- PARTIAL MILLING OF PAVEMENT FOR AN OPERATION WILL NOT BE PAID FOR SEPARATELY, BUT WILL BE PAID FOR AT THE FINAL MILLING THICKNESS SHOWN ON THE TYPICAL SECTIONS.
- EPOXY PAVEMENT MARKING LINES SHALL BE USED FOR TEMPORARY PAVEMENT MARKINGS.
- REMOVAL OF EXISTING PAVEMENT MARKING, WHEN REQUIRED, SHALL BE PAID FOR AS "PAVEMENT MARKING REMOVAL."
- EXISTING OR TEMPORARY PAVEMENT MARKINGS REMOVED DURING MILLING OPERATIONS WILL NOT BE PAID FOR SEPARATELY.
- CASTINGS EXPOSED IN TRAVEL LANES SHALL BE PROTECTED PER APPLICABLE PORTIONS OF ARTICLE 603.07 OF THE STANDARD SPECIFICATIONS. THIS WORK WILL NOT BE PAID FOR SEPARATELY, BUT SHALL BE INCLUDED IN THE VARIOUS HMA/SMA BINDER AND SURFACE COURSES PLACED.
- OMIT STAGE III OPERATIONS THROUGH BRIDGE AND CONCRETE SECTIONS.
- SIGNS SHALL BE INSTALLED AS INSTRUCTED BELOW.

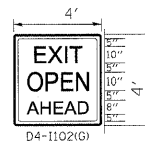

1" BORDER LINE
GREEN REFLECTIVE
BACKGROUND
WITH WHITE LEGEND

SIGN SHALL BE INSTALLED
IN ADVANCE OF ALL OPEN/EXIT
RAMPS WHEN THE RIGHT
LANES ARE CLOSED.



SIGN SHALL BE INSTALLED
ON BOTH SIDES OF THE ROADWAY
500' IN ADVANCE OF AREAS WHERE
THERE IS A GRADE DIFFERENTIAL
BETWEEN LANES, AFTER EACH
ENTRANCE RAMP AND A MINIMUM
OF EVERY MILE.

- THE CONTRACTOR SHALL COORDINATE THE ROADWAY AND STRUCTURAL WORK SO BITUMINOUS MATERIALS ARE NOT TRACKED ON THE BRIDGE DECKS BEFORE BEING SEALED.
- "EPOXY PAVEMENT MARKING - LETTERS AND SYMBOLS" SHALL BE INSTALLED ON MAINLINE ROADWAY DURING STAGE III OPERATIONS, IN LOCATIONS WHERE LETTERS/SYMBOLS PAVEMENT MARKINGS EXIST PRIOR TO SURFACE REVOVAL.
- WORK ZONE SPEED LIMIT SIGNS SHALL REMAIN IN PLACE UNTIL ALL BINDER IS PLACED.

LEGEND

- EXISTING PAVEMENT MARKING
- EPOXY PAVEMENT MARKING - LINE 5" (WHITE 10' DASH, 30' SKIP)
- EPOXY PAVEMENT MARKING - LINE 4" (YELLOW LEFT & WHITE RIGHT)
- PROPOSED PAVEMENT MARKING. SEE PAVEMENT MARKING PLANS.

TYPE II BARRIER, DRUM, OR VERTICAL
BARRICADE WITH STEADY BURN
MONODIRECTIONAL LIGHT

BITUMINOUS SURFACE REMOVAL

HMA/SMA BINDER AND SURFACE COURSES

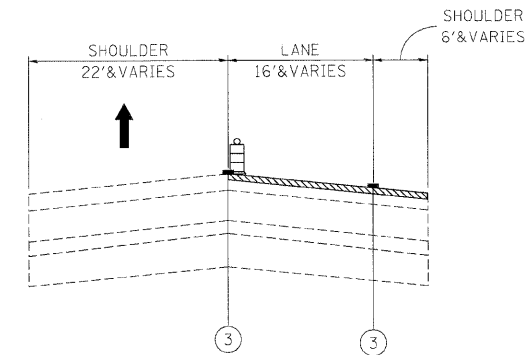

STAGE III - OPERATION THREE - EB IL-38 TO I-88 RAMP

BITUMINOUS SURFACE REMOVAL FINAL 1-3/4" - SHOULDER
BITUMINOUS SURFACE REMOVAL FINAL 2" - LANE

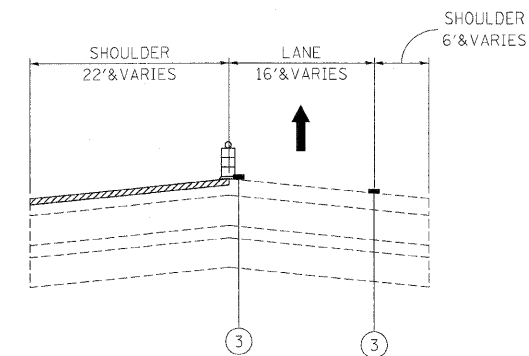

STAGE III - OPERATION FOUR - EB IL-38 TO I-88 RAMP

BITUMINOUS SURFACE REMOVAL FINAL 1-3/4" - SHOULDER

FILE NAME =	DESIGNED - AJP	REVISED -	benesch	STATE OF ILLINOIS DEPARTMENT OF TRANSPORTATION	MAINTENANCE OF TRAFFIC TYPICAL SECTION - STAGE 3			F.A.I. RTE.	SECTION	COUNTY	TOTAL SHEETS	SHEET NO.
...\\prip1h\ABC\02.m1.mot.typ.st.3.12.dgn	DRAWN - TMB	REVISED -			290	(3031.1, ETC., 3838)RS-5	COOK	298	187			
USER NAME = tblank	CHECKED - JLT	REVISED -			CONTRACT NO. 60G52							
PLOT DATE = 11/13/2009	DATE = 10/16/09	REVISED -			SCALE:	SHEET NO. 93 OF 96 SHEETS	STA.	TO STA.	FED. ROAD DIST. NO.	ILLINOIS FED. AID PROJECT		