

### STAGE III

#### STAGE III NOTES

- SEQUENCE OF CONSTRUCTION: PAVEMENT PATCHING, HMA SURFACE REMOVAL AND PROPOSED HMA COURSES AS DETAILED IN EACH OPERATION SECTION. WORK CAN OCCUR CONCURRENTLY, BUT SEQUENCE SHALL BE MAINTAINED AND NOT CONFLICT. RAMP WORK WILL BE COMPLETED USING DISTRICT DETAIL TC-8 - FREEWAY AND EXIT RAMP CLOSURE DETAILS.
- LANE AND RAMP CLOSURES ALLOWED AS STIPULATED IN THE SPECIAL PROVISIONS. CONTRACTOR MAY NOT CLOSE ADJACENT EXIT OR ENTRANCE RAMP AT THE SAME TIME.
- SURFACE REMOVAL AND RESURFACING OPERATIONS SHALL NOT BEGIN UNTIL STAGE II IS COMPLETED.
- LANE CLOSURES PER STANDARDS 701400, 701401 AND 701446.
- REDUCE LANE WIDTH USING 35:1 TAPER PER DISTRICT DETAIL TC-9 - TRAFFIC CONTROL DETAILS FOR FREEWAY SINGLE AND MULTI-LANE WEAVE, A W5-1 (48 X 48) ROAD NARROWS SIGN WILL BE ERECTED 500' IN ADVANCE OF THE TAPER.
- THE CONTRACTOR SHALL ERECT ROAD CONSTRUCTION AHEAD SIGNS (W20-110310-48) WITH FLASHING BEACON ON ALL ARTERIAL ROADWAYS APPROACHING INTERCHANGE RAMP.
- GRADE DIFFERENTIAL BETWEEN LANES SHALL NOT EXCEED 2".
- PARTIAL MILLING OF PAVEMENT FOR AN OPERATION WILL NOT BE PAID FOR SEPARATELY, BUT WILL BE PAID FOR AT THE FINAL MILLING THICKNESS SHOWN ON THE TYPICAL SECTIONS.
- EPOXY PAVEMENT MARKING LINES SHALL BE USED FOR TEMPORARY PAVEMENT MARKINGS.
- REMOVAL OF EXISTING PAVEMENT MARKING, WHEN REQUIRED, SHALL BE PAID FOR AS "PAVEMENT MARKING REMOVAL."
- EXISTING OR TEMPORARY PAVEMENT MARKINGS REMOVED DURING MILLING OPERATIONS WILL NOT BE PAID FOR SEPARATELY.
- CASTINGS EXPOSED IN TRAVEL LANES SHALL BE PROTECTED PER APPLICABLE PORTIONS OF ARTICLE 603.07 OF THE STANDARD SPECIFICATIONS. THIS WORK WILL NOT BE PAID FOR SEPARATELY, BUT SHALL BE INCLUDED IN THE VARIOUS HMA/SMA BINDER AND SURFACE COURSES PLACED.
- OMIT STAGE III OPERATIONS THROUGH BRIDGE AND CONCRETE SECTIONS.
- SIGNS SHALL BE INSTALLED AS INSTRUCTED BELOW.

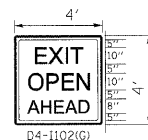

1" BORDER LINE  
GREEN REFLECTIVE  
BACKGROUND  
WITH WHITE LEGEND

SIGN SHALL BE INSTALLED  
IN ADVANCE OF ALL OPEN/EXIT  
RAMP WHEN THE RIGHT  
LANES ARE CLOSED.



W8-11  
48" X 48"

SIGN SHALL BE INSTALLED  
ON BOTH SIDES OF THE ROADWAY  
500' IN ADVANCE OF AREAS WHERE  
THERE IS A GRADE DIFFERENTIAL  
BETWEEN LANES, AFTER EACH  
ENTRANCE RAMP AND A MINIMUM  
OF EVERY MILE.

- THE CONTRACTOR SHALL COORDINATE THE ROADWAY AND STRUCTURAL WORK SO BITUMINOUS MATERIALS ARE NOT TRACKED ON THE BRIDGE DECKS BEFORE BEING SEALED.
- "EPOXY PAVEMENT MARKING - LETTERS AND SYMBOLS" SHALL BE INSTALLED ON MAINLINE ROADWAY DURING STAGE III OPERATIONS, IN LOCATIONS WHERE LETTERS/SYMBOLS PAVEMENT MARKINGS EXIST PRIOR TO SURFACE REMOVAL.
- WORK ZONE SPEED LIMIT SIGNS SHALL REMAIN IN PLACE UNTIL ALL BINDER IS PLACED.

#### LEGEND

- ① EXISTING PAVEMENT MARKING
- ② EPOXY PAVEMENT MARKING - LINE 5" (WHITE 10' DASH, 30' SKIP)
- ③ EPOXY PAVEMENT MARKING - LINE 4" (YELLOW LEFT & WHITE RIGHT)
- ④ PROPOSED PAVEMENT MARKING. SEE PAVEMENT MARKING PLANS.

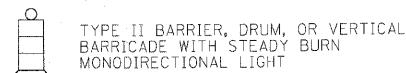

BITUMINOUS SURFACE REMOVAL

HMA/SMA BINDER AND SURFACE COURSES

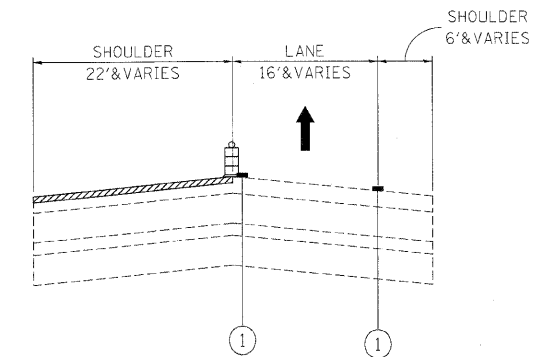

**STAGE III - OPERATION ONE - EB IL-38 TO I-88 RAMP**  
BITUMINOUS SURFACE REMOVAL 2" - SHOULDER

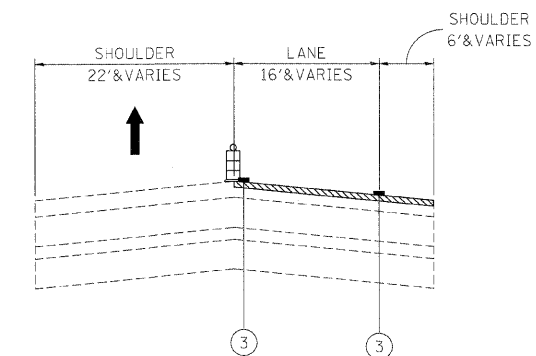

**STAGE III - OPERATION TWO - EB IL-38 TO I-88 RAMP**  
BITUMINOUS SURFACE REMOVAL 2" - LANE AND SHOULDER

FILE NAME =	DESIGNED - AJP	REVISED -	<b>benesch</b>	<b>STATE OF ILLINOIS DEPARTMENT OF TRANSPORTATION</b>	<b>MAINTENANCE OF TRAFFIC TYPICAL SECTION - STAGE 3</b>			F.A.I. RTE.	SECTION	COUNTY	TOTAL SHEETS	SHEET NO.
...\\prph\ABC_C2\el_mot_ttp.st.3.11.dgn	DRAWN - TMB	REVISED -			290	13031.1, ETC., 3838RS-5	COOK	298	186			
USER NAME = tb:ank	CHECKED - JJT	REVISED -			CONTRACT NO. 60652							
PLOT DATE = 11/13/2009	DATE - 10/16/09	REVISED -			SCALE:	SHEET NO. 92 OF 96 SHEETS	STA.	TO STA.	FED. ROAD DIST. NO.	ILLINOIS FED. AID PROJECT		