

DETAIL C
(Typical top & bottom flanges)

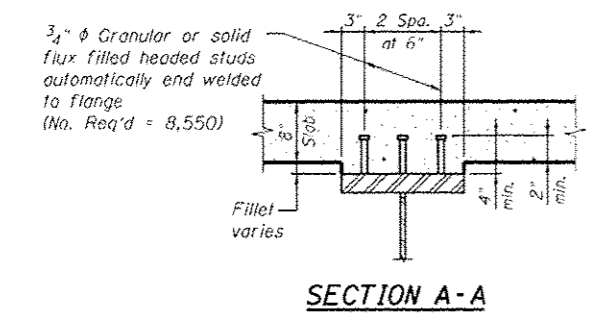

SECTION A-A

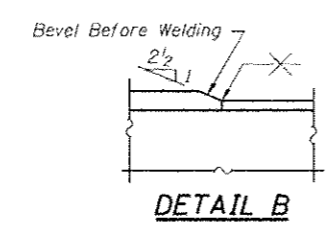

DETAIL B

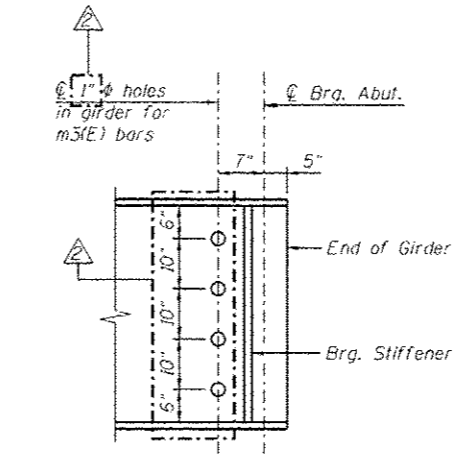

END OF GIRDER ELEVATION

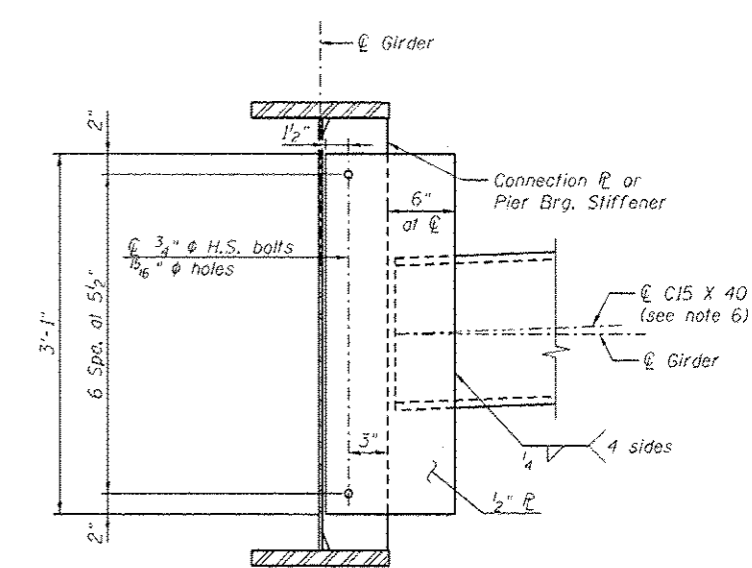

INTERIOR DIAPHRAGM
(No. diaphragms required = 88)

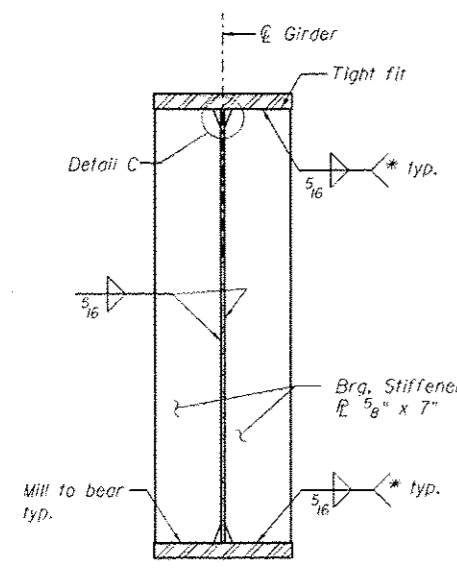

BEARING STIFFENER AT ABUT.
(No. plates required = 40)

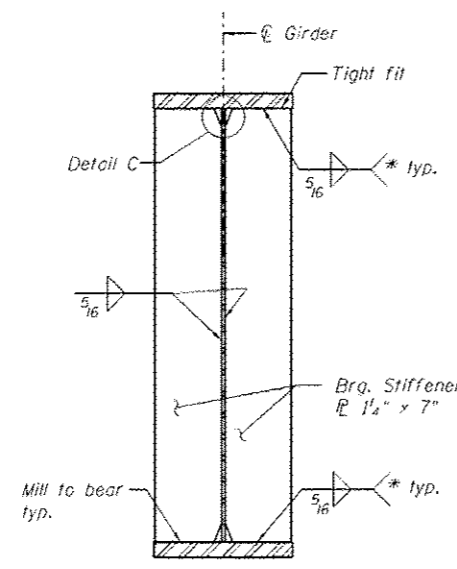

BEARING STIFFENER AT PIER
(No. plates required = 20)

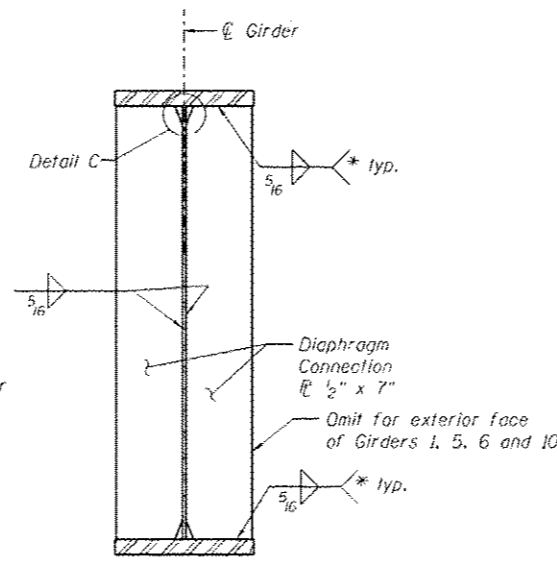

CONNECTION PLATE
(No. plates required = 168)

* Terminate weld 1/2" from outside edges of R's

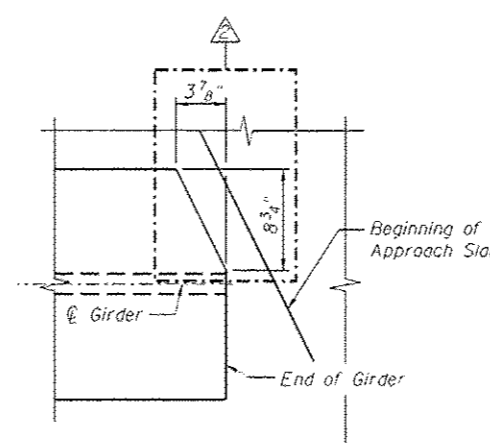

END OF GIRDER COPING DETAIL
(Top Flange Only)

- NOTES:**
- All Girder webs and flanges shall be AASHTO M270 Grade 50 steel.
 - All diaphragms shall be installed as steel is erected and secured with erection pins and bolts except as otherwise noted. Individual diaphragms at supports may be temporarily disconnected to install bearing anchor rods.
 - "NTR" denotes plates to which notch toughness requirements are applicable.
 - Load carrying components designated "NTR" shall conform to the Impact Testing Requirements, Zone 2.
 - Two hardened washers required for each set of oversized holes.
 - Alternate channels C15x50 are permitted to facilitate material acquisition. Calculated weight of structural steel is based on C15x40 sections. The alternate, if utilized, shall be provided at no extra cost to the department.

benesch
engineers - scientists - planners
Alfred Benesch & Company
205 North Michigan Avenue, Suite 2400
Chicago, Illinois 60601
312-565-0450 Job No. 10056

FILE NAME -	USER NAME - mbecker	DESIGNED - JLS/DTS	REVISED - 2/ 10/23/2012 MFB
0908165_68620_21_sdt.dgn	PLT SOURCE -	CHECKED - MRB	REVISED -
	PLT DATE - 10/22/2012	DRAWN - PRT	REVISED -
		CHECKED - MRB	REVISED -

STATE OF ILLINOIS
DEPARTMENT OF TRANSPORTATION

GIRDER DETAILS 1 OF 3
STRUCTURE NO. 090-0165 / 0166
SHEET NO. SA21 OF SA47 SHEETS

F.A.I. RTE.	SECTION	COUNTY	TOTAL SHEETS	SHEET NO.
74	90-(14R)14HB-4,14,14HYB1BR	TAZEWELL	2433	1885
CONTRACT NO. 68620			ILLINOIS FED. AID PROJECT	

x:\10000\10056\engineering-documents-phase.1\155cover.174\final\0900165-68620-21.sdt.dgn 10/22/2012 3:30:03 PM