

DIAPHRAGM AT APPROACH BENT

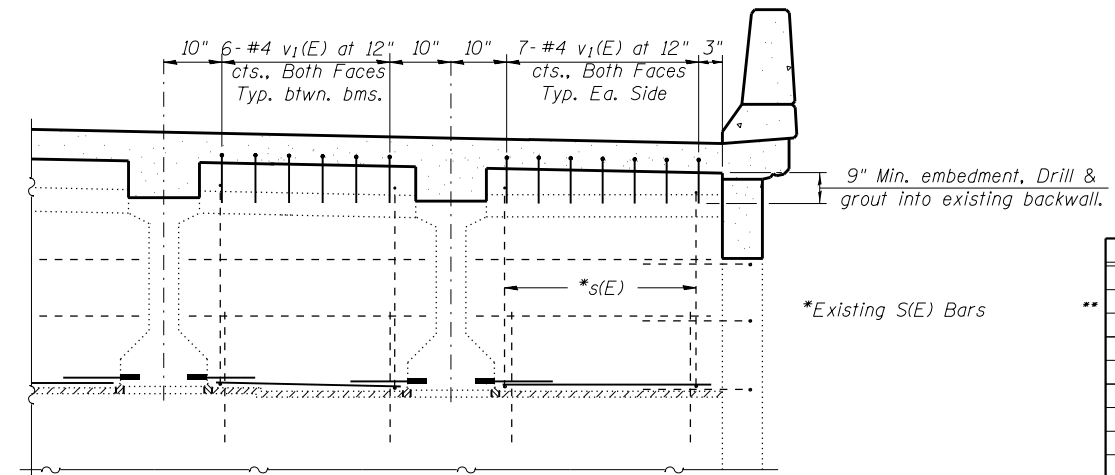

DIAPHRAGM AT ABUTMENT

TWO APPROACH SPANS  
BILL OF MATERIAL

Bar	No.	Size	Length	Shape
a(E)	208	#5	26'-6"	—
a1(E)	148	#5	26'-4"	—
a2(E)	104	#6	6'-6"	—
a3(E)	4	#6	16'-10"	—
a4(E)	8	#6	26'-9"	—
a6(E)	178	#5	16'-8"	—
b3(E)	152	#5	27'-1"	—
b4(E)	156	#5	27'-2"	—
d(E)	124	#5	5'-7"	—
d2(E)	120	#5	6'-10"	—
e8(E)	56	#4	13'-6"	—
e9(E)	4	#8	27'-3"	—
e1d(E)	4	#4	27'-3"	—
v1(E)	300	#5	2'-4"	1
v2(E)	224	#5	1'-5"	—
z1(E)	220	#5	2'-6"	—
z2(E)	110	#5	4'-10"	—
z3(E)	336	#5	3'-6"	—
Reinforcement Bars, Epoxy Coated			Pound	28,930
Concrete Superstructure			Cu. Yd.	124.8

\*\*Diagrams for a1(E) and z1(E) Bars on Sheet 9 of 25.

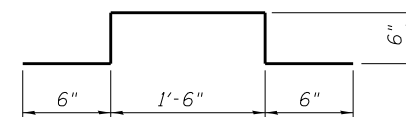

BAR z3(E)

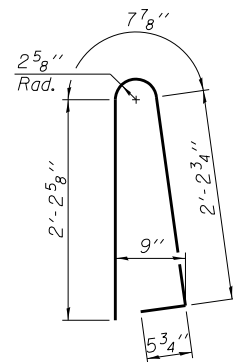

BAR d(E)

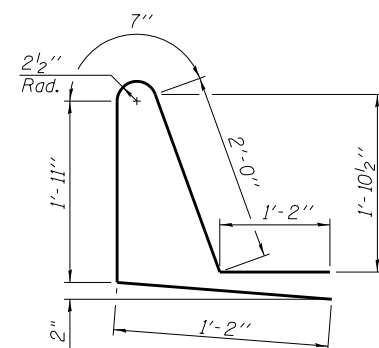

BAR d2(E)

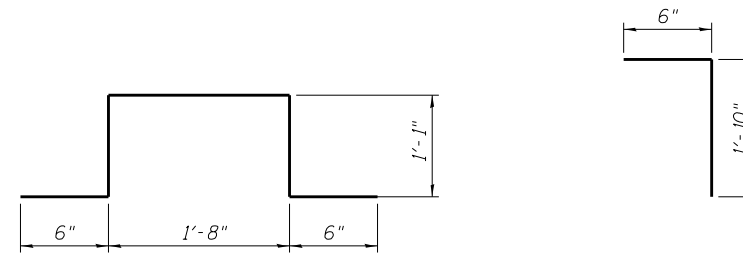

BAR z2(E)

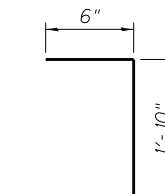

BAR v1(E)