

STATE OF ILLINOIS  
DEPARTMENT OF TRANSPORTATION

ROUTE NO.	SECTION	COUNTY	TOTAL SHEETS	SHEET NO.
94/90	*	COOK	588	269
FED. ROAD DIST. NO. 1	ILLINOIS	FED. AID PROJECT		

\* 62303 (2021-922 PT2 ETC 2324.6-1P) R-11

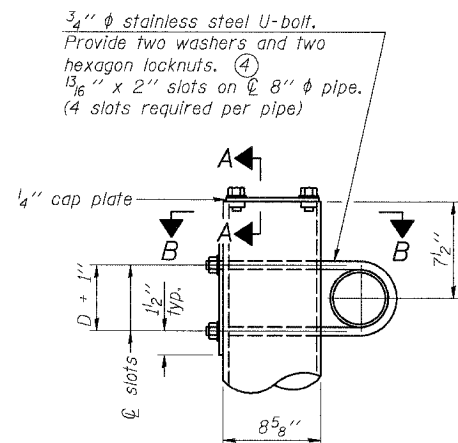

DETAIL A

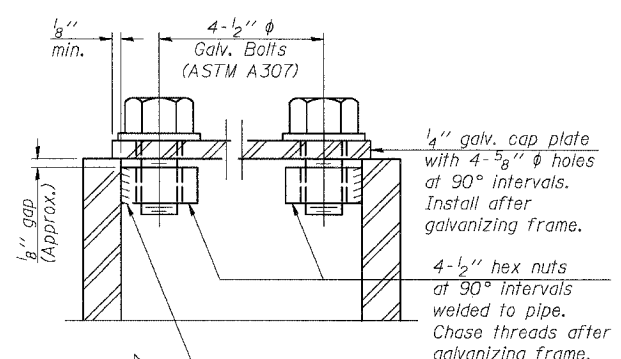

SECTION A-A

As an alternate to bolts, may use galvanized drive-fit caps installed after galvanizing frame.

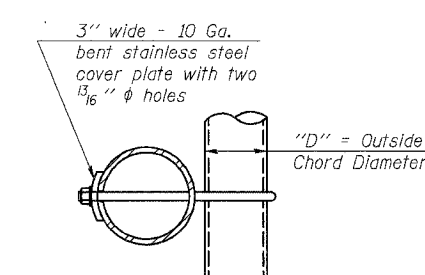

SECTION B-B

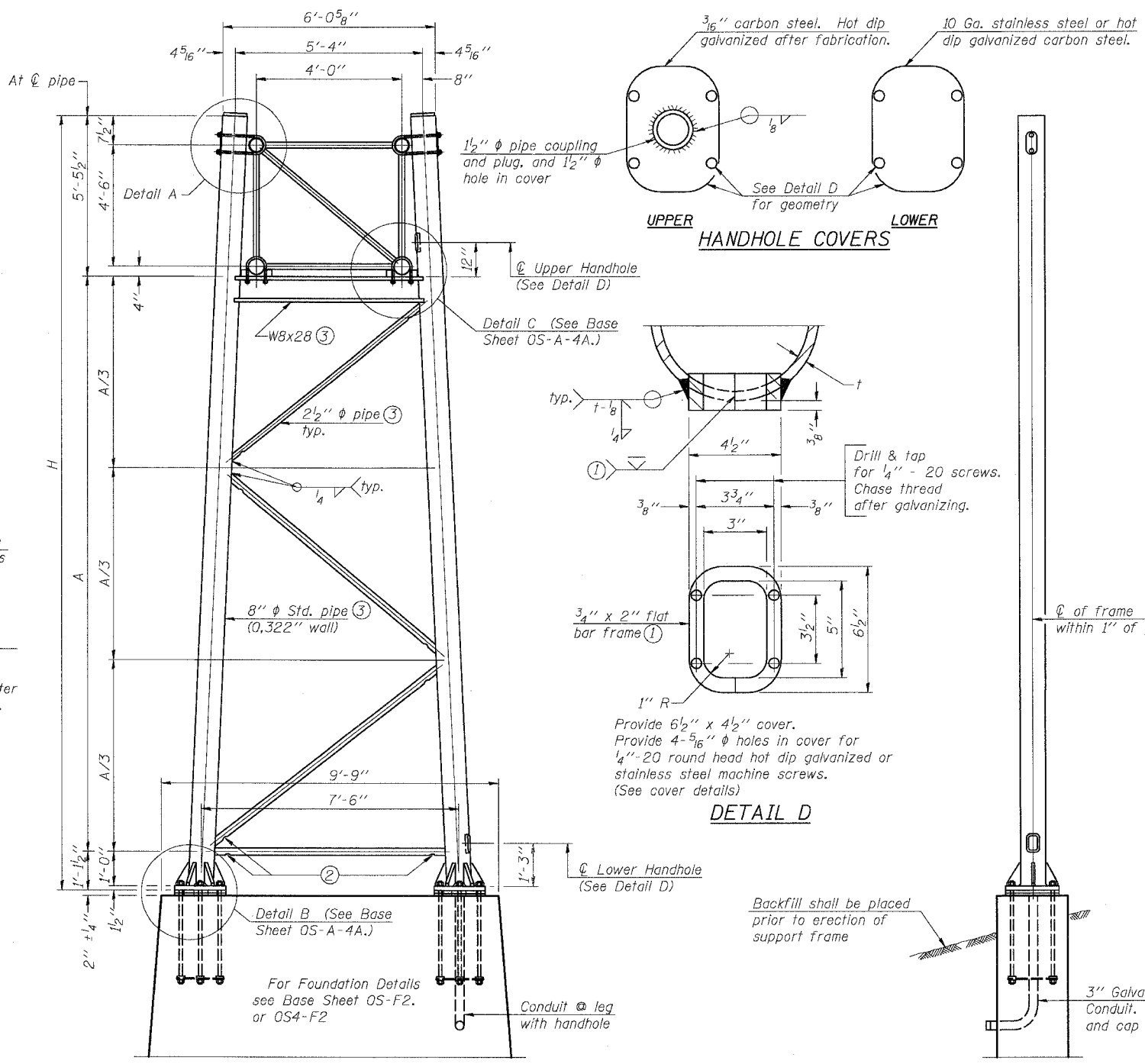

SIDE ELEVATION

END ELEVATION

8"  $\phi$  PIPE TRUSS SUPPORT FRAME

Support Design Loads: See Base Sheet OS-A-1 for design and loading criteria.  
Load combinations checked include deadload plus:  
a) 100% wind normal to sign, 20% parallel to sign  
b) 60% wind normal to sign, 30% parallel to sign

- ① In lieu of fabricated handhole frame as shown, may cut from 2" plate \*rolling direction vertical\*. All cut faces to be ground to ANSI Roughness of 500 min or less.
- ② Galvanizing vent holes of adequate size shall be provided on underside at each end of bracing pipes. Alternately, holes may be provided in wall of pipe column. All vent holes shall be drilled and de-burred, typ.
- ③ Steel pipe, plate, carbon steel handhole covers and rolled sections shall be hot dip galvanized after fabrication. Painting is not permitted. See Base Sheet OS-A-1.
- ④ See General Notes for fasteners.
- ⑤ Dimensions shown are based on selection criteria in the Sign Structures Manual. Nonstandard applications must have dimensions verified or amended as appropriate.

Structure Number	Station	Support		H	A
		Left	Right		
ISO161094R057.4	3493+30	X		22.59'	16.01'
ISO161094R057.4	3493+30		X	20.66'	14.08'
ISO161094R056.02	3566+30	X		24'-3 3/8"	17'-8 3/8"
ISO161094R056.02	3566+30		X	23'-8 3/4"	17'-1 3/4"
ISO161094R055.46	3596+00	X		23'-2 1/4"	16'-7 1/4"
ISO161094R055.46	3596+00		X	22'-2 3/4"	15'-7 1/4"
ISO161094R055.08	3616+00	X		25'-1 1/8"	18'-6 1/8"
ISO161094R055.08	3616+00		X	23'-9 5/8"	17'-2 5/8"

SGN-19

OVERHEAD SIGN STRUCTURES  
SUPPORT FRAME for TYPE I-A ALUMINUM TRUSS

ILLINOIS DEPARTMENT OF TRANSPORTATION  
F.A.I. 94/90 (DAN RYAN EXPRESSWAY)  
GARFIELD BLVD TO 31st STREET (SB LOCAL LANES)  
OVERHEAD SIGN STRUCTURES  
(SPAN)

DESIGNED	AC	EXAMINED	20
CHECKED	AS	PASSED	ENGINEER OF STRUCTURAL SERVICES
DRAWN	RV		ENGINEER OF BRIDGES AND STRUCTURES
CHECKED	MSA		

NUMBER	REVISION	DATE
▲	ADDENDUM 2	8/04/06

OS-A-4

1-7-05