

LEGEND

- ① EXISTING +/- 2 3/4" HMA
- ② EXISTING +/-10" P.C.C. BASE
- ③ EXISTING B-6.24 CURB AND GUTTER
- ④ EXISTING SHOULDER +/-8"
- ⑤ HMA SURFACE REMOVAL - 2 3/4" (SEE NOTE 1)
- ⑥ HOT-MIX ASPHALT SURFACE COURSE, MIX "D", N70 (IL-9.5mm) -3"
- ⑦ POLYMERIZED LEVELING BINDER (MACHINE METHOD), IL-4.75, N50 -1"
- ⑧ POLYMERIZED HOT-MIX ASPHALT SURFACE COURSE, STONE MATRIX ASPHALT, N80 -2"
- ⑨ HMA SURFACE REMOVAL - 2"
- ⑩ PORTLAND CEMENT CONCRETE SURFACE REMOVAL VARIABLE DEPTH (SEE HMA TAPER AT EDGE OF P.C.C. PAVEMENT DETAIL)
- ⑪ HOT-MIX ASPHALT SURFACE COURSE, MIX "D", N70 (IL-9.5mm) -2"
- ⑫ POLYMERIZED LEVELING BINDER (MACHINE METHOD), IL-4.75, N50 -3/4"
- ⑬ HMA SURFACE REMOVAL, VARIABLE DEPTH
- ⑭ STRIP REFLECTIVE CRACK CONTROL TREATMENT

NOTES

1. THE CONTRACTOR SHALL PERFORM THE PAVEMENT PATCHING OPERATIONS PRIOR TO THE HMA SURFACE REMOVAL OPERATION. SEE IDOT DISTRICT 1 DETAIL PAVEMENT PATCHING FOR HMA SURFACED PAVEMENT BD-400-04 (BD-22) FOR ADDITIONAL INFORMATION.
2. NO ADDITIONAL COMPENSATION WILL BE GIVEN TO THE CONTRACTOR FOR ANY EXTRA WORK REQUIRED TO REMOVE THE HMA SHOULDER ADJACENT TO THE EXISTING BARRIER WALL. THIS WORK WILL BE INCLUDED IN THE CONTRACT UNIT PRICE FOR HMA SURFACE REMOVAL - 2" AND HMA SURFACE REMOVAL VARIABLE DEPTH.

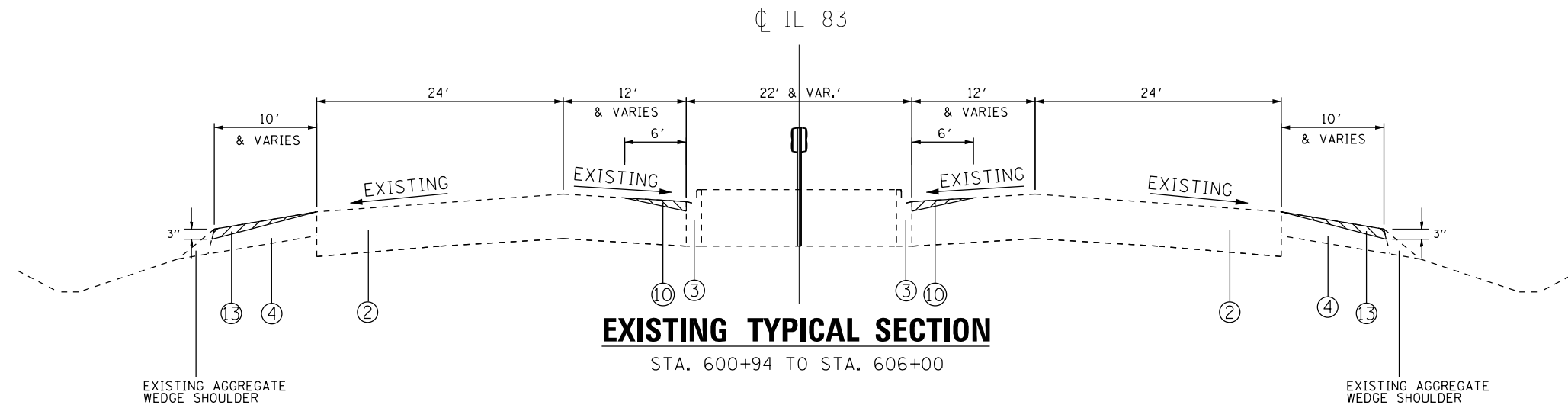

EXISTING TYPICAL SECTION

STA. 600+94 TO STA. 606+00

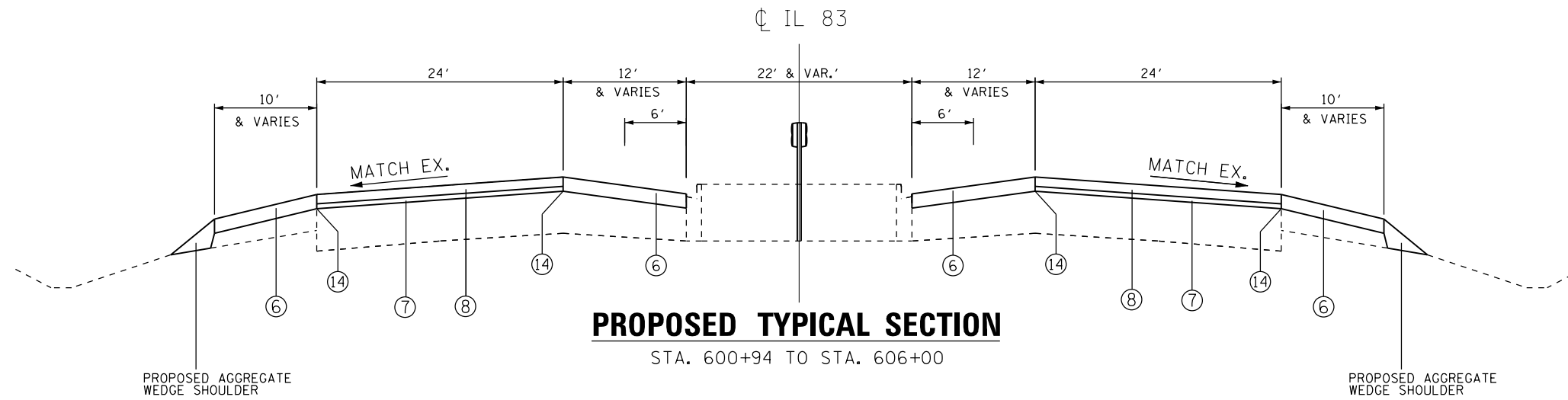

PROPOSED TYPICAL SECTION

STA. 600+94 TO STA. 606+00

FILE NAME =	USER NAME = marenade	DESIGNED -	REVISED -	STATE OF ILLINOIS	TYPICAL SECTIONS IL ROUTE 83 (KINGERY HIGHWAY) KNOLLWOOD ROAD TO IL ROUTE 56 (BUTTERFIELD ROAD)	F.A.P. RTE.	SECTION	COUNTY	TOTAL SHEETS	SHEET NO.	
Default	2111-sht-plan.dgn	DRAWN -	REVISED -			344	543R-3-RS	DUPAGE	51	12	
	PLOT SCALE = 100.0000' / in.	CHECKED -	REVISED -			CONTRACT NO. 60N51					
	PLOT DATE = 6/13/2014	DATE -	REVISED -			SHEET 2 OF 4 SHEETS		STA. TO STA.		ILLINOIS FED. AID PROJECT	