

HORIZONTAL CONTROL

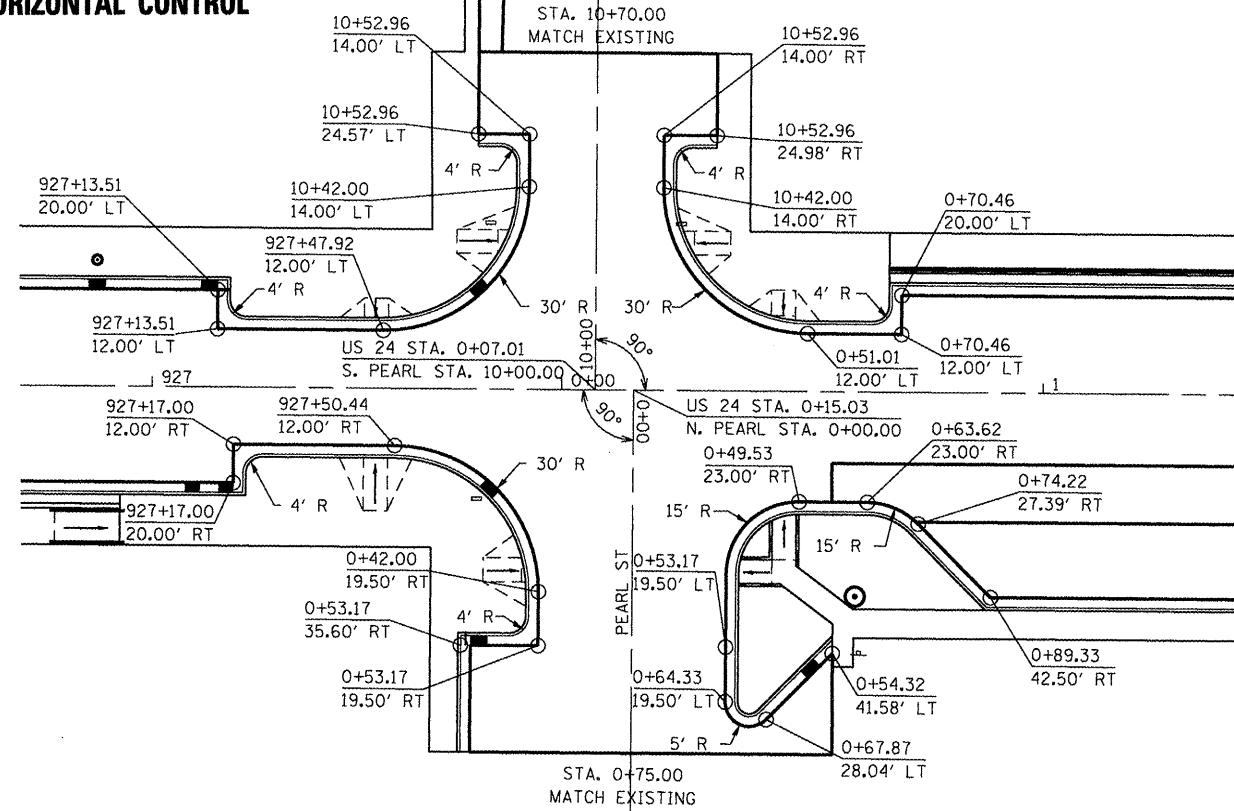

VERTICAL CONTROL

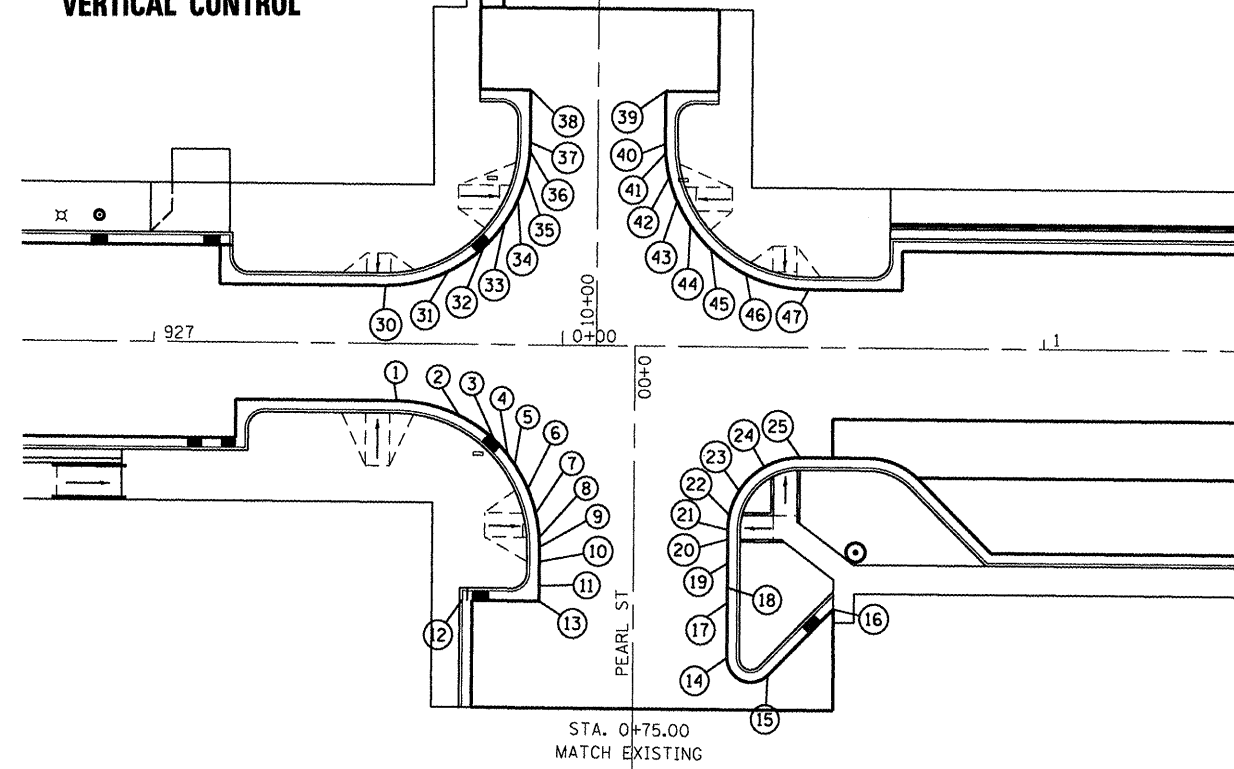

NOTES:

1. SEE SIDEROAD PROFILES.
2. TYPICAL TRANSVERSE JOINT SPACING ON US 24 BETWEEN INTERSECTIONS SHALL BE 14'.

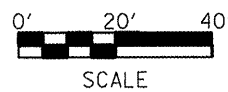

LOCATION	STATION	OFFSET	ELEVATION
N. PEARL ST			
1	0+12.00	49.50	710.79
2	0+15.00	36.42	710.46
3	0+20.00	29.10	710.24
4	0+23.00	26.28	710.29
5	0+25.00	24.78	710.32
6	0+30.00	22.00	710.36
7	0+35.00	20.33	710.40
8	0+40.00	19.57	710.43
9	0+42.00	19.50	710.44
10	0+45.00	19.50	710.46
11	0+50.00	19.50	710.51
12	0+53.17	35.60	710.36
13	0+53.17	19.50	710.54
14	0+64.33	19.50	710.66
15	0+67.87	28.04	710.66
16	0+54.31	41.59	710.35
17	0+53.17	19.50	710.44

18	0+50.00	19.50	710.41
19	0+45.00	19.50	710.35
20	0+40.00	19.50	710.32
21	0+35.00	19.50	710.30
22	0+30.00	19.80	710.28
23	0+28.00	21.81	710.23
24	0+25.00	27.02	710.16
25	0+23.00	34.50	710.08

LOCATION	STATION	OFFSET	ELEVATION
S. PEARL ST			
30	10+12.00	44.00	710.75
31	10+15.00	30.92	710.62
32	10+20.00	23.60	710.46
33	10+25.00	19.28	710.34
34	10+30.00	16.50	710.24
35	10+35.00	14.83	710.16
36	10+40.00	14.07	710.07
37	10+42.00	14.00	710.04
38	10+52.96	14.00	709.40
39	10+52.96	14.00	709.47
40	10+42.00	14.00	709.98
41	10+40.00	14.07	710.01
42	10+35.00	14.83	710.06
43	10+30.00	16.50	710.11
44	10+25.00	19.28	710.15
45	10+20.00	23.60	710.19
46	10+15.00	30.92	710.24
47	10+12.00	44.00	710.18