

SECTION B-B

EXPANSION JOINT AT PIERS
(Existing)

NOTE:
Work This Sheet With Sht's. S4 & S6

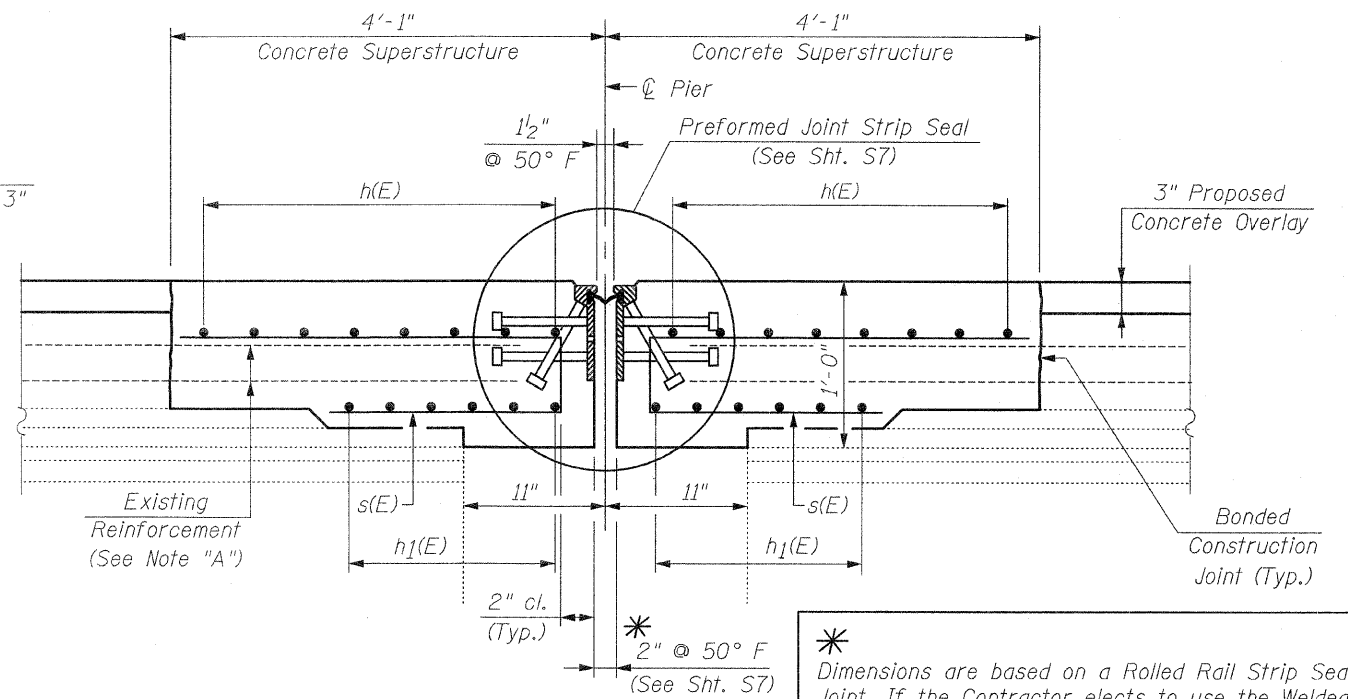

SECTION B-B

EXPANSION JOINT AT PIERS
(Proposed)

* Dimensions are based on a Rolled Rail Strip Seal Joint. If the Contractor elects to use the Welded Rail Strip Seal Joint, deck dimensions may require adjustments to match the details on Sht. S7

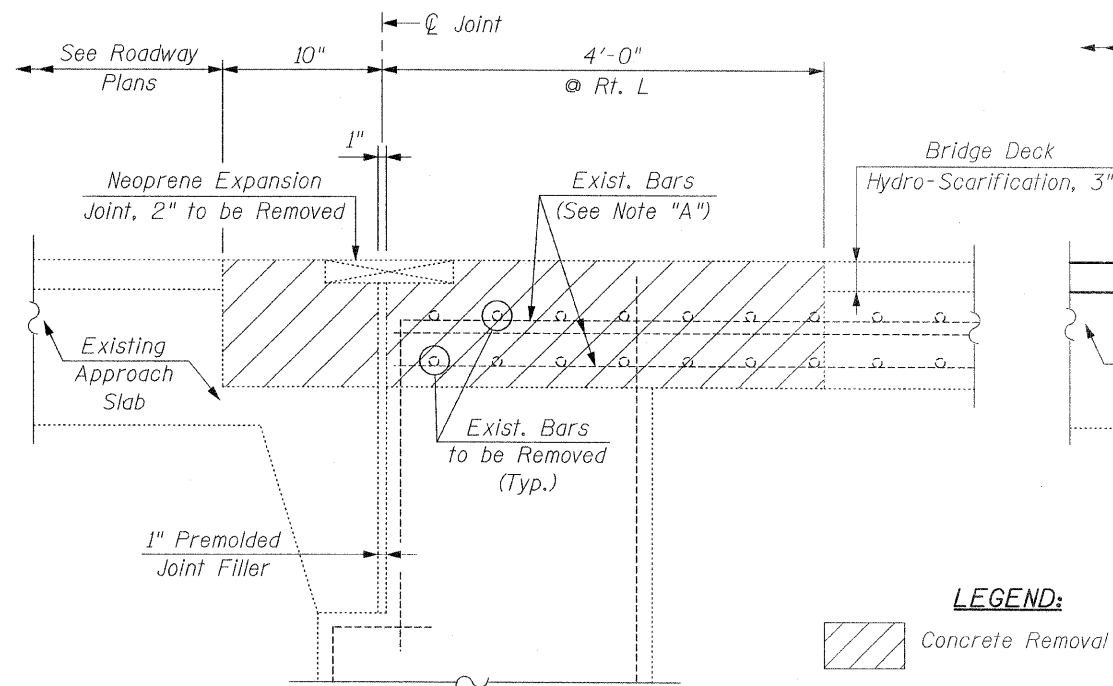

SECTION A-A

EXPANSION JOINT AT ABUTMENTS
(Existing)

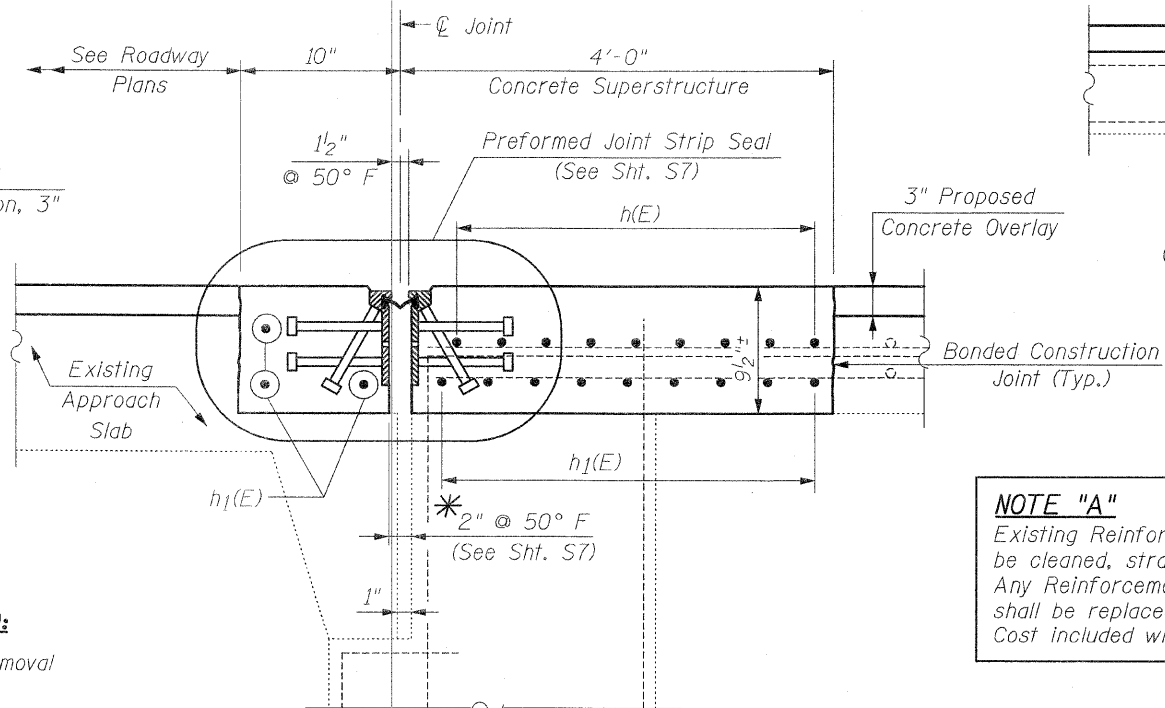

SECTION A-A

EXPANSION JOINT AT ABUTMENTS
(Proposed)

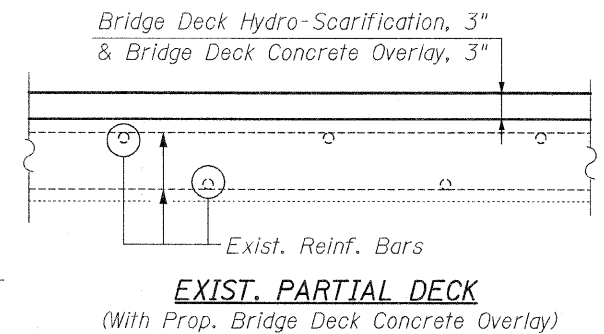

EXIST. PARTIAL DECK
(With Prop. Bridge Deck Concrete Overlay)

NOTE "A"
Existing Reinforcement Bars extending into the Removal Area shall be cleaned, straightened and incorporated into the New Construction. Any Reinforcement Bars that are damaged during Concrete Removal shall be replaced with an approved Bar Splicer or Anchorage System. Cost included with Concrete Removal.

LEGEND:
Concrete Removal

FILE NAME = exp_jt-reconst-II.sht	USER NAME = I00T	DESIGNED - B.N.S.	REVISED -
		DRAWN - R.E.S./D.L./F.M.	REVISED -
		CHECKED - B.N.S./J.C.N.	REVISED -
		DATE - JANUARY 15, 2009	REVISED -

STATE OF ILLINOIS
DEPARTMENT OF TRANSPORTATION

EXPANSION JOINT RECONSTRUCTION - II
IL. 72 OVER I-90
S.N. 045-0074

SCALE: SHEET NO. 55 OF 58 SHEETS STA. TO STA.

F.A.P. RTE. 341	SECTION N-4-C-I	COUNTY KANE	TOTAL SHEETS 32	SHEET NO. 17
FED. ROAD DIST. NO. ILLINOIS FED. AID PROJECT			CONTRACT NO. 60D72	

CR & A CHRISTIAN-ROGE & ASSOCIATES, INC.
ENGINEERS / PLANNERS / SURVEYORS
211 W. WACKER DRIVE CHICAGO, IL. 60606
PHONE: (312)372-2023 FAX: (312)372-5274